



24 VDC Pulse Motor

RCP2 & RCP3

with dedicated controllers
PCON and PSEL

Catalogue Extract 4th revised Edition B



RCP3 series	Coupled Type	Aluminum Base	22mm width	RCP3-SA2AC	3
			28mm width	RCP3-SA2BC	5
			32mm width	RCP3-SA3C	7
			40mm width	RCP3-SA4C	9
			50mm width	RCP3-SA5C	11
			60mm width	RCP3-SA6C	13
Slider	Side-Mounted Motor Type	Aluminum Base	22mm width	RCP3-SA2AR	15
			28mm width	RCP3-SA2BR	17
			32mm width	RCP3-SA3R	19
			40mm width	RCP3-SA4R	21
			50mm width	RCP3-SA5R	23
			60mm width	RCP3-SA6R	25

RCP2 series	Coupled Type	Aluminum Base	52mm width	RCP2-SA5C	27
			58mm width	RCP2-SA6C	29
			73mm width	RCP2-SA7C	31
		Steel Base	60mm width	RCP2-SS7C	33
			80mm width	RCP2-SS8C	35
		High-Speed Type	80mm width	RCP2-HS8C	37
Slider	Side-Mounted Motor Type	Aluminum Base	52mm width	RCP2-SA5R	39
			58mm width	RCP2-SA6R	41
			73mm width	RCP2-SA7R	43
		Steel Base	60mm width	RCP2-SS7R	45
			80mm width	RCP2-SS8R	47
			High-Speed Type	80mm width	RCP2-HS8R
Belt Type	58mm width	RCP2-BA6/BA6U	51		
	68mm width	RCP2-BA7/BA7U	53		

RCP3 series Rod	Mini Rod Type	Coupling Type	22mm width	RCP3-RA2AC	131
			28mm width	RCP3-RA2BC	133
	Side-Mounted Motor Type	22mm width	RCP3-RA2AR	135	
		28mm width	RCP3-RA2BR	137	

RCP2 series Rod	Standard Type	Coupling Type	25mm width	RCP2-RA2C	139
			35mm width	RCP2-RA3C	141
			45mm width	RCP2-RA4C	143
			64mm width	RCP2-RA6C	145
			85mm width	RCP2-RA8C	146-1
			100mm width	RCP2-RA10C	147
	Side-Mounted Motor Type	85mm width	RCP2-RA8R	148-1	
		45mm width	RCP2-SRA4R	149	
Rod	Single-Guide Type	Coupling Type	45mm width	RCP2-RGS4C	151
			64mm width	RCP2-RGS6C	153
	Side-Mounted Motor Type	45mm width	RCP2-SRGS4R	155	
		Double-Guide Type	Coupling Type	35mm width	RCP2-RGD3C
	45mm width			RCP2-RGD4C	159
			64mm width	RCP2-RGD6C	161
			45mm width	RCP2-SRGD4R	163

RCP3 series Table	Table Type	Inline Motor	36mm width	RCP3-TA3C	269
			40mm width	RCP3-TA4C	271
			55mm width	RCP3-TA5C	273
			65mm width	RCP3-TA6C	275
			75mm width	RCP3-TA7C	277
	Side-Mounted Motor	36mm width	RCP3-TA3R	279	
		40mm width	RCP3-TA4R	281	
		55mm width	RCP3-TA5R	283	
		65mm width	RCP3-TA6R	285	
		75mm width	RCP3-TA7R	287	

RCP2 series Gripper	2-Finger-Gripper	Mini Slider Type	42 mm width	RCP2-GRSS	333
			Mini Lever Type	42 mm width	RCP2-GRLS
		Small Slider Type	69 mm width	RCP2-GRS	337
		Medium Slider-Type	74 mm width	RCP2-GRM	339
		Medium High-force Slider Type	116 mm width	RCP2-GRHM	340-1
		Large High-force Slider Type	131 mm width	RCP2-GRHB	340-3
		Long Stroke Slider Type	130 mm width		
			190 mm width	RCP2-GRST	341
	3-Finger Gripper	Lever Type	62 mm width	RCP2-GR3LS	343
80 mm width			RCP2-GR3LM	345	
Slider Type		62 mm width	RCP2-GR3SS	347	
		80 mm width	RCP2-GR3SM	349	

RCP2 series Rotary	Rotary	Small Vertical Type	45 mm width	RCP2-RTBS/RTBSL	353
			Small Flat Type	72 mm width	RCP2-RTCS/RTCSL
		Medium Vertical Type	50 mm width	RCP2-RTB / RTBL	357
		Medium Flat Type	88 mm width	RCP2-RTC / RTCL	359
		Large Vertical Type	76 mm width	RCP2-RTBB / RTBBL	361
		Large Flat Type	124 mm width	RCP2-RTCB / RTCBL	363

RCP2CR series Cleanroom	Slider Coupling Type	Aluminum Base	52mm width	RCP2CR-SA5C	399
			58mm width	RCP2CR-SA6C	401
			73mm width	RCP2CR-SA7C	403
		Steel Base	60mm width	RCP2CR-SS7C	405
			80mm width	RCP2CR-SS8C	407
		High-Speed Type	80mm width	RCP2CR-HS8C	409
Gripper Type	Mini Slider Type	42mm width	RCP2CR-GRSS	411	
	Mini Lever Type	42mm width	RCP2CR-GRLS	413	

RCP2W series Damp room	Slider Type	Coupled	158mm width	RCP2W-SA16C	443
			Rod Type	Coupled	45mm width
		64mm width		RCP2W-RA6C	447
		High-thrust Type	100mm width	RCP2W-RA10C	449
Gripper Type	Mini Slider Type	42mm width	RCP2W-GRSS	451	
	Mini Lever type	42mm width	RCP2W-GRLS	453	

- Slider Type
- Mini
- Standard
- Controllers Integrated
- Rod Type
- Mini
- Standard
- Controllers Integrated
- Table/Arm /Flat Type
- Mini
- Standard
- Gripper/ Rotary Type
- Linear Motor Type
- Cleanroom Type
- Splash-Proof
- Controllers
- PMEC /AMEC
- PSEP /ASEP
- ROBO NET
- ERC2
- PCON
- ACON
- SCON
- PSEL
- ASEL
- SSEL
- XSEL
- Pulse Motor
- Servo Motor (24V)
- Servo Motor (230V)
- Linear Motor

RCP3-SA2AC

RoboCylinder Mini Slider Type Coupled Motor 22mm Width Pulse Motor Lead Screw

■ Configuration: **RCP3** — **SA2AC** — **I** — **20P** — — — — —

Series	Type	Encoder	Motor	Lead	Stroke	Compatible Controllers	Cable Length	Option
		I: Incremental * The Simple absolute encoder is also considered type "I".	20P: Pulse motor 20 □ size	4S: 4mm lead screw 2S: 2mm lead screw 1S: 1mm lead screw	25: 25mm 100: 100mm (25mm pitch increments)	P1: PCON RPCON PSEL P3: PMEC PSEP	N: None P: 1m S: 3m M: 5m X □ □: Custom Length	NM: Reversed-home

* See page Pre-35 for explanation of each code that make up the configuration name.

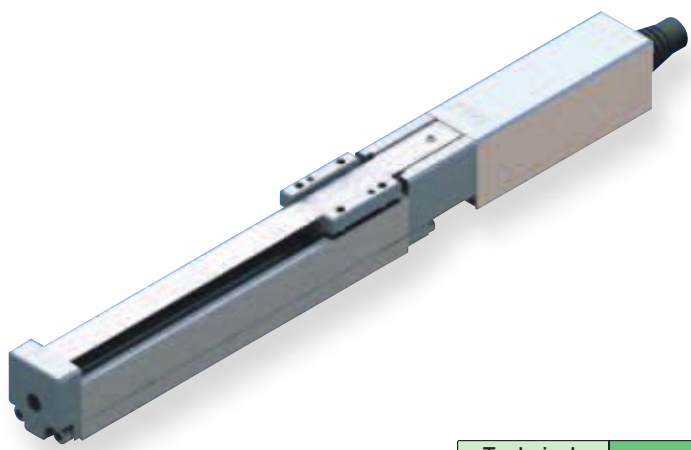

Technical References A-5

■ **Speed vs. Load Capacity**
Due to the characteristics of the pulse motor, the RCP3 series' load capacity decreases at high speeds. In the table below, check if your desired speed and load capacity are supported.

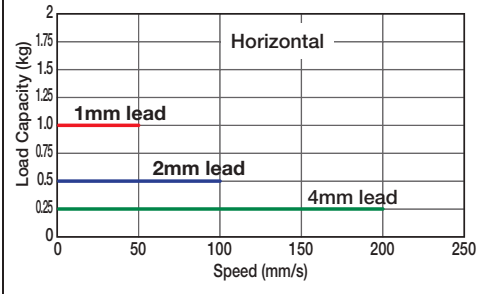

- POINT** Notes on Selection
- (1) The load capacity is based on operation at an acceleration of 0.2G. This is the upper limit for the acceleration.
 - (2) The actuator cannot be used on its side or in a vertical orientation.
 - (3) If used in a dusty environment, the service life will decrease significantly.
 - (4) This model uses a lead screw, therefore please ensure that your usage is appropriate for its characteristics. (See page Pre-42.)

Actuator Specifications							Stroke and Maximum Speed		
■ Lead and Load Capacity									
Model	Feed Screw	Lead (mm)	Max. Load Capacity		Positioning Repeatability (mm)	Stroke (mm)	Stroke		
			Horizontal (kg)	Vertical (kg)			Lead	50 ~ 100 (mm)	
RCP3-SA2AC-I-20P-4S-①-②-③-④	Lead screw	4	0.25	—	±0.05	25~100 (25 increments)	4	180	200
RCP3-SA2AC-I-20P-2S-①-②-③-④		2	0.5	—			2	100	
RCP3-SA2AC-I-20P-1S-①-②-③-④		1	1	—			1	50	

Legend ① Stroke ② Compatible Controller ③ Cable Length ④ Options (Unit: mm/s)

Cable List	
Type	Cable Symbol
Standard (Robot Cables)	P (1m)
	S (3m)
	M (5m)
Special Lengths	X06 (6m) ~ X10 (10m)
	X11 (11m) ~ X15 (15m)
	X16 (16m) ~ X20 (20m)

* The standard cable for the RCP3 is the robot cable.
* See page A-39 for cables for maintenance.

Actuator Specifications	
Item	Description
Drive System	Lead screw (Ø4mm, C10 grade)
Lost Motion	0.3mm or less (initial value)
Base	Material: Aluminum (white alumite treated)
Guide	Slide guide
Ambient Operating Temp./Humidity	0~40°C, 85% RH or less (non-condensing)
Service Life	10 million cycles

Option List			
Name	Option Code	See Page	
Reversed-home	NM	→ A-33	

- Slider Type
- Mini
- Standard
- Controllers Integrated
- Rod Type
- Mini
- Standard
- Controllers Integrated
- Table/Arm /Flat Type
- Mini
- Standard
- Gripper/ Rotary Type
- Linear Motor Type
- Cleanroom Type
- Splash-Proof
- Controllers
- PMEC /AMEC
- PSEP /ASEP
- ROBO NET
- ERC2
- PCON
- ACON
- SCON
- PSEL
- ASEL
- SSEL
- XSEL
- Pulse Motor
- Servo Motor (24V)
- Servo Motor (230V)
- Linear Motor

Dimensions

CAD drawings can be downloaded from IAI website. www.robocylinder.de

For Special Orders A-9



- *1: A motor-encoder cable is connected here. See page A-39 for details on cables.
- *2: During the homing operation, the slider moves to actuator's mechanical end, and then reverses. Therefore, watch for any interference with its surroundings.

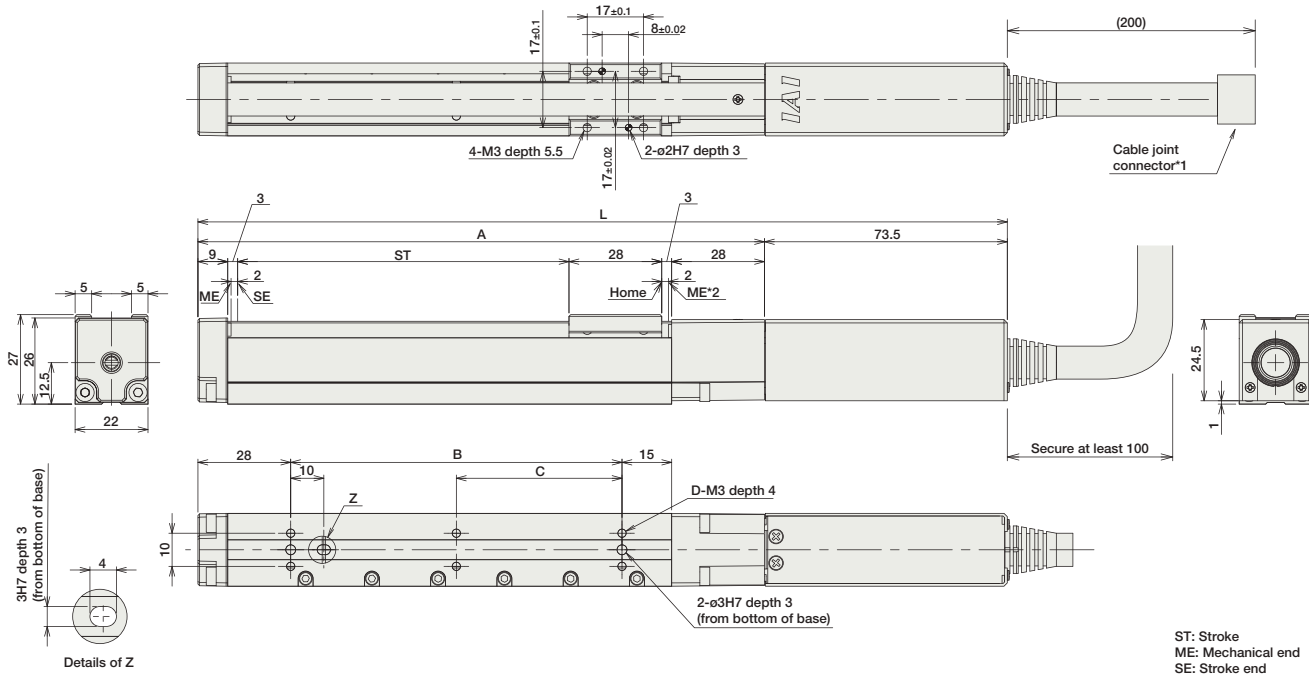

■ Dimensions/Weight by Stroke

Stroke	25	50	75	100
L	169.5	194.5	219.5	244.5
A	96	121	146	171
B	25	50	75	100
C	0	0	0	50
D	4	4	4	6
Weight (kg)	0.25	0.27	0.29	0.3

Compatible Controllers

The RCP3 series actuators can operate with the controllers below. Select the controller according to your usage.

Name	External View	Model	Description	Max. Positioning Points	Input Voltage	Power Supply Capacity	See Page
Solenoid Valve Type		PMEC-C-20PI-NP-2-2	Easy-to-use controller, even for beginners	3 points	AC115V AC230V	See P481	→ P477
		PSEP-C-20PI-NP-2-0	Operable with same signal as solenoid valve. Supports both single and double solenoid types.				
Splash-Proof Solenoid Valve Type		PSEP-CW-20PI-NP-2-0	No homing necessary with simple absolute type.				→ P487
Positioner Type		PCON-C-20PI-NP-2-0	Positioning is possible for up to 512 points	512 points	DC24V	2A max.	
Safety-Compliant Positioner Type		PCON-CG-20PI-NP-2-0					
Pulse Train Input Type (Differential Line Driver)		PCON-PL-20PI-NP-2-0	Pulse train input type with differential line driver support	(-)	DC24V	2A max.	→ P525
Pulse Train Input Type (Open Collector)		PCON-PO-20PI-NP-2-0	Pulse train input type with open collector support				
Serial Communication Type		PCON-SE-20PI-N-0-0	Dedicated to serial communication	64 points			
Field Network Type		RPCON-20P	Dedicated to field network	768 points			→ P503
Program Control Type		PSEL-C-1-20PI-NP-2-0	Programmed operation is possible. Can operate up to 2 axes	1500 points			→ P557

* This is for the single-axis PSEL.

- Slider Type
- Mini
- Standard
- Controllers Integrated
- Rod Type
- Mini
- Standard
- Controllers Integrated
- Table/Arm /Flat Type
- Mini
- Standard
- Gripper/ Rotary Type
- Linear Motor Type
- Cleanroom Type
- Splash-Proof
- Controllers
- PMEC /AMEC
- PSEP /ASEP
- ROBO NET
- ERC2
- PCON
- ACON
- SCON
- PSEL
- ASEL
- SSEL
- XSEL
- Pulse Motor
- Servo Motor (24V)
- Servo Motor (230V)
- Linear Motor

RCP3-SA2BC

RoboCylinder Mini Slider Type Coupled Motor 28mm Width Pulse Motor Lead Screw

■ Configuration: **RCP3** — **SA2BC** — **I** — **20P** — — — — —

Series — Type — Encoder — Motor — Lead — Stroke — Compatible Controllers — Cable Length — Option

I: Incremental * The Simple absolute encoder is also considered type "I".
 20P: Pulse motor 20 □ size
 6S: 6mm lead screw 25: 25mm
 4S: 4mm lead screw 150: 150mm (25mm pitch increments)
 2S: 2mm lead screw
 P1: PCON RPCON PSEL P3: PMECPSEP
 N: None P: 1m S: 3m M: 5m X □ □: Custom Length
 NM: Reversed-home

* See page Pre-35 for explanation of each code that make up the configuration name.

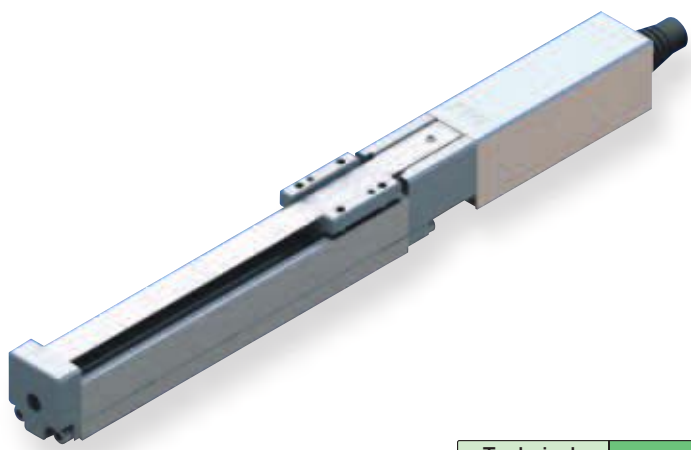

Technical References A-5

■ Speed vs. Load Capacity
 Due to the characteristics of the pulse motor, the RCP3 series' load capacity decreases at high speeds. In the table below, check if your desired speed and load capacity are supported.

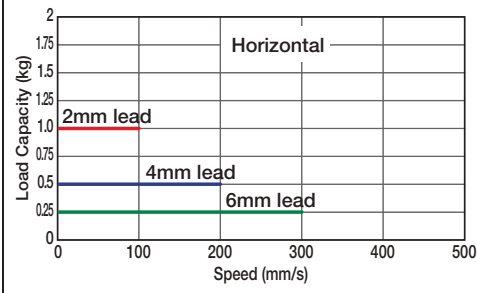

- POINT** Notes on Selection
- (1) The load capacity is based on operation at an acceleration of 0.2G. This is the upper limit for the acceleration.
 - (2) The actuator cannot be used on its side or in a vertical orientation.
 - (3) If used in a dusty environment, the service life will decrease significantly.
 - (4) This model uses a lead screw, therefore please ensure that your usage is appropriate for its characteristics. (See page Pre-42.)

Actuator Specifications							Stroke and Maximum Speed			
■ Lead and Load Capacity							■ Stroke and Maximum Speed			
Model	Feed Screw	Lead (mm)	Max. Load Capacity		Positioning Repeatability (mm)	Stroke (mm)	Stroke			
			Horizontal (kg)	Vertical (kg)			Lead	25 (mm)	50 (mm)	75~150 (mm)
RCP3-SA2BC-I-20P-6S-①-②-③-④	Lead screw	6	0.25	—	±0.05	25~150 (25 increments)	6	180	280	300
RCP3-SA2BC-I-20P-4S-①-②-③-④		4	0.5	—			4	180	200	
RCP3-SA2BC-I-20P-2S-①-②-③-④		2	1	—			2	100		

Legend ① Stroke ② Compatible Controller ③ Cable Length ④ Options (Unit: mm/s)

Type	Cable Symbol
Standard (Robot Cables)	P (1m)
	S (3m)
	M (5m)
Special Lengths	X06 (6m) ~ X10 (10m)
	X11 (11m) ~ X15 (15m)
	X16 (16m) ~ X20 (20m)

* The standard cable for the RCP3 is the robot cable.
 * See page A-39 for cables for maintenance.

Item	Description
Drive System	Lead screw Ø6mm C10 grade
Lost Motion	0.3mm or less (initial value)
Base	Material: Aluminum (white alumite treated)
Guide	Slide guide
Ambient Operating Temp./Humidity	0~40°C, 85% RH or less (non-condensing)
Service Life	10 million cycles

Name	Option Code	See Page
Reversed-home	NM	→ A-33

Dimensions

CAD drawings can be downloaded from IAI website. www.robocylinder.de

For Special Orders  A-9



- *1: A motor-encoder cable is connected here. See page A-39 for details on cables.
- *2: During the homing operation, the slider moves to actuator's mechanical end, and then reverses. Therefore, watch for any interference with its surroundings.

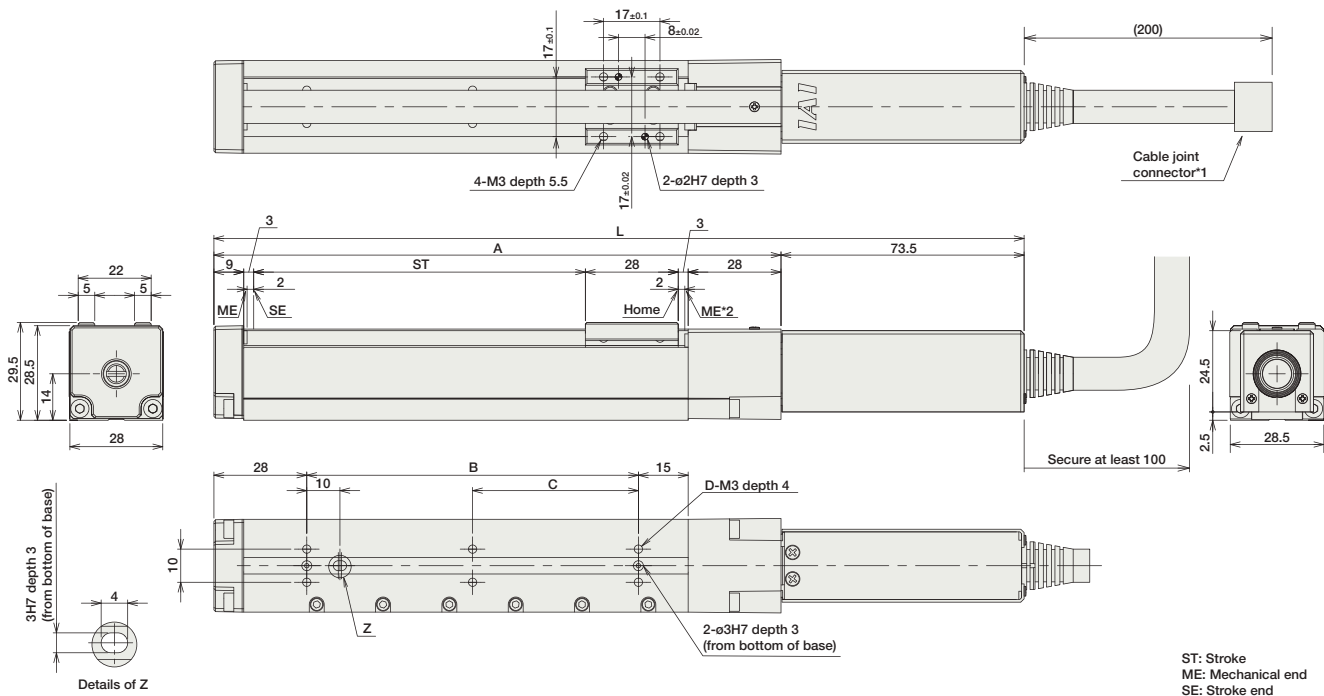

■ Dimensions/Weight by Stroke

Stroke	25	50	75	100	125	150
L	169.5	194.5	219.5	244.5	269.5	294.5
A	96	121	146	171	196	221
B	25	50	75	100	125	150
C	0	0	0	50	62.5	75
D	4	4	4	6	6	6
Weight (kg)	0.3	0.32	0.35	0.37	0.4	0.42

Compatible Controllers

The RCP3 series actuators can operate with the controllers below. Select the controller according to your usage.

Name	External View	Model	Description	Max. Positioning Points	Input Voltage	Power Supply Capacity	See Page
Solenoid Valve Type		PMEC-C-20PI-NP-2-2	Easy-to-use controller, even for beginners	3 points	AC115V AC230V	See P481	→ P477
		PSEP-C-20PI-NP-2-0	Operable with same signal as solenoid valve. Supports both single and double solenoid types.				→ P487
Splash-Proof Solenoid Valve Type		PSEP-CW-20PI-NP-2-0	No homing necessary with simple absolute type.				
Positioner Type		PCON-C-20PI-NP-2-0	Positioning is possible for up to 512 points	512 points	DC24V	2A max.	
Safety-Compliant Positioner Type		PCON-CG-20PI-NP-2-0					
Pulse Train Input Type (Differential Line Driver)		PCON-PL-20PI-NP-2-0	Pulse train input type with differential line driver support	(-)	DC24V	2A max.	→ P525
Pulse Train Input Type (Open Collector)		PCON-PO-20PI-NP-2-0	Pulse train input type with open collector support				
Serial Communication Type		PCON-SE-20PI-N-0-0	Dedicated to serial communication	64 points			
Field Network Type		RPCON-20P	Dedicated to field network	768 points			→ P503
Program Control Type		PSEL-C-1-20PI-NP-2-0	Programmed operation is possible. Can operate up to 2 axes	1500 points			→ P557

* This is for the single-axis PSEL.

- Slider Type
- Mini
- Standard
- Controllers Integrated
- Rod Type
- Mini
- Standard
- Controllers Integrated
- Table/Arm /Flat Type
- Mini
- Standard
- Gripper/ Rotary Type
- Linear Motor Type
- Cleanroom Type
- Splash-Proof
- Controllers
- PMEC /AMEC
- PSEP /ASEP
- ROBO NET
- ERC2
- PCON
- ACON
- SCON
- PSEL
- ASEL
- SSEL
- XSEL
- Pulse Motor
- Servo Motor (24V)
- Servo Motor (230V)
- Linear Motor

- Slider Type
- Mini
- Standard
- Controllers Integrated
- Rod Type
- Mini
- Standard
- Controllers Integrated
- Table/Arm /Flat Type
- Mini
- Standard
- Gripper/ Rotary Type
- Linear Motor Type
- Cleanroom Type
- Splash-Proof
- Controllers
- PMEC /AMEC
- PSEP /ASEP
- ROBO NET
- ERC2
- PCON
- ACON
- SCON
- PSEL
- ASEL
- SSEL
- XSEL
- Pulse Motor
- Servo Motor (24V)
- Servo Motor (230V)
- Linear Motor

RCP3-SA3C RoboCylinder Slider Type 32mm Width Pulse Motor Coupled

■ Configuration: **RCP3** — **SA3C** — **I** — **28P** — — — — —

Series — Type — Encoder — Motor — Lead — Stroke — Compatible Controllers — Cable Length — Option

I: Incremental 28P: Pulse motor 6: 6mm 50: 50mm P1: PCON N: None See Options below
 * The Simple absolute encoder models are labeled as "I". 28 □ size 4: 4mm 300: 300mm P: 1m P: 1m RPCON PSEL P3: PMECC PSEP
 S: 3m M: 5m X □ □: Custom Length
 (50mm pitch increments)

* See page Pre-35 for explanation of each code that make up the configuration name.

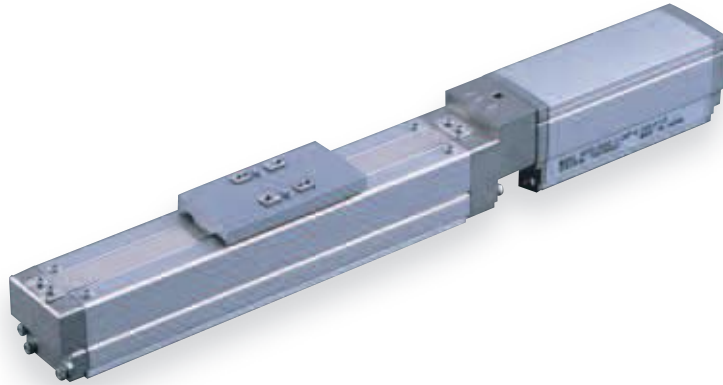

Technical References A-5

POINT Notes on Selection

(1) Since the RCP3 series use a pulse motor, the load capacity decreases at high speeds. Check in the Speed vs. Load Capacity graph to see if your desired speed and load capacity are supported.

(2) The load capacity is based on operation at an acceleration of 0.3G (0.2G for 2mm-lead model, or when used vertically). These values are the upper limits for the acceleration.

■ Speed vs. Load Capacity
 Due to the characteristics of the pulse motor, the RCP3 series' load capacity decreases at high speeds. In the table below, check if your desired speed and load capacity are supported.

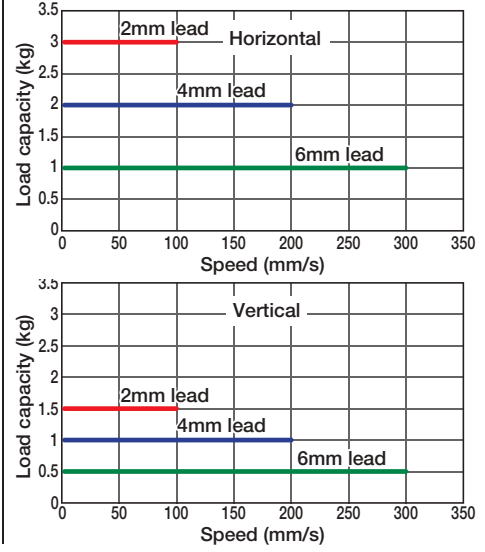

Actuator Specifications					Stroke and Maximum Speed	
■ Lead and Load Capacity					Stroke	
Model	Lead (mm)	Max. Load Capacity		Maximum Push Force (N)	Stroke (mm)	50 ~ 300 (50mm increments)
		Horizontal (kg)	Vertical (kg)			
RCP3-SA3C-I-28P-6-①-②-③-④	6	1	0.5	15	50 ~ 300 (50mm increments)	300
RCP3-SA3C-I-28P-4-①-②-③-④	4	2	1	22		200
RCP3-SA3C-I-28P-2-①-②-③-④	2	3	1.5	44		100

Legend ① Stroke ② Compatible controller ③ Cable length ④ Options (Unit: mm/s)

Cable List	
Type	Cable Symbol
Standard (Robot Cables)	P (1m)
	S (3m)
	M (5m)
Special Lengths	X06 (6m) ~ X10 (10m)
	X11 (11m) ~ X15 (15m)
	X16 (16m) ~ X20 (20m)

* The standard cable is the motor-encoder integrated robot cable.
 * See page A-39 for cables for maintenance.

Option List		
Name	Option Code	See Page
Brake-Equipped	B	→ A-25
Cable Exit Direction (Top)	CJT	→ A-25
Cable Exit Direction (Right)	CJR	→ A-25
Cable Exit Direction (Left)	CJL	→ A-25
Cable Exit Direction (Bottom)	CJB	→ A-25
No Cover	NCO	→ A-33
Reversed-home	NM	→ A-33

Actuator Specifications	
Item	Description
Drive System	Ball screw Ø6mm C10 grade
Positioning Repeatability	±0.02mm
Lost Motion	0.1mm or less
Base	Material: Aluminum (special alumite treated)
Allowable Static Moment	Ma: 5.0N·m Mb: 7.1N·m Mc: 7.9 N·m
Allowable Dynamic Moment(*)	Ma: 1.96N·m Mb: 2.84N·m Mc: 3.14N·m
Overhang Load Length	100mm or less
Ambient Operating Temp./Humidity	0~40°C, 85% RH or less (non-condensing)

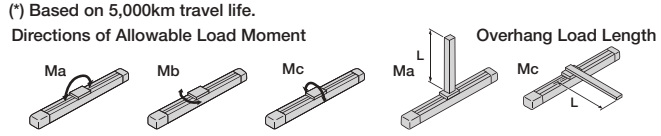

Dimensions

CAD drawings can be downloaded from IAI website. www.robocylinder.de



For Special Order P. A-9

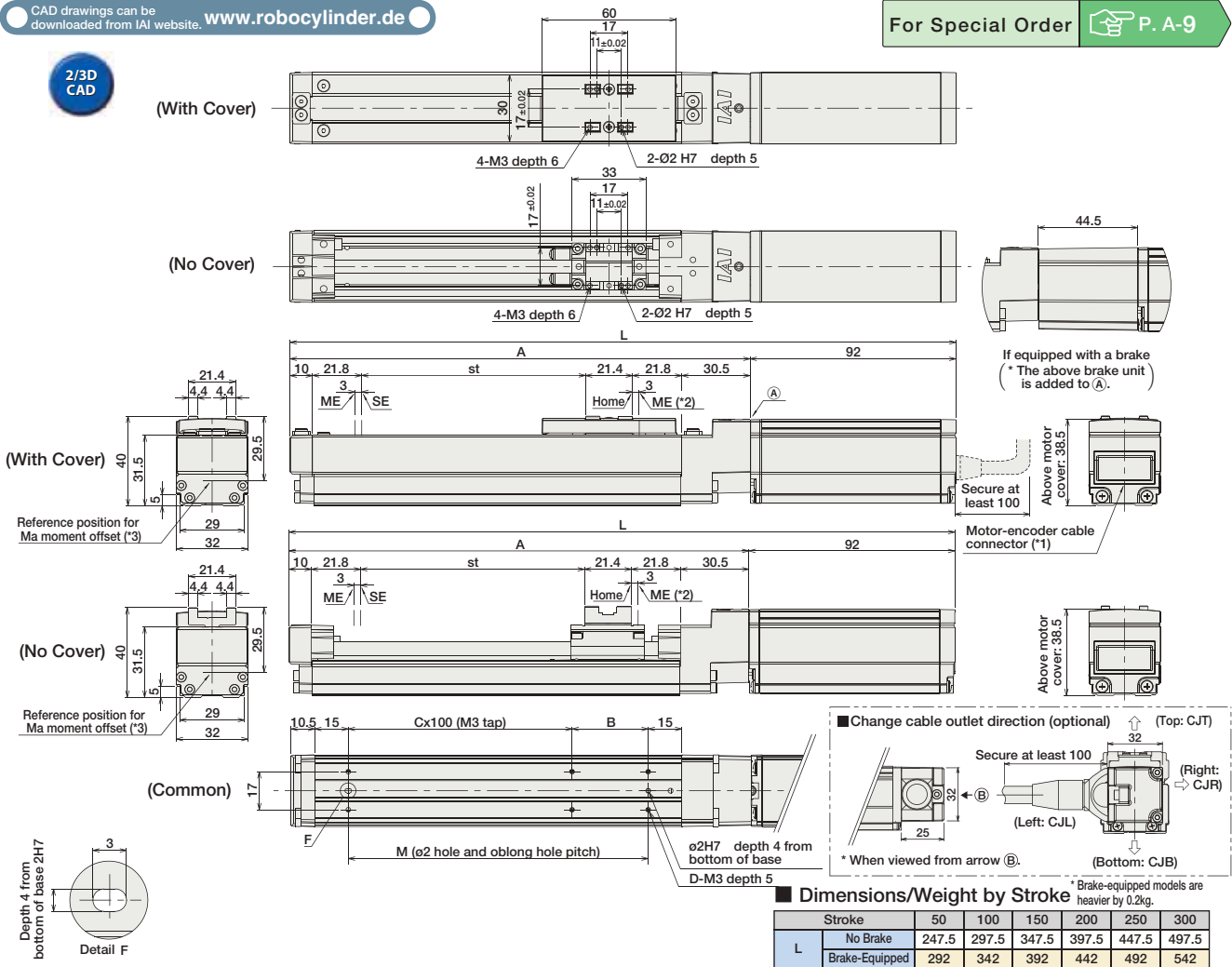

(*1) A Motor-encoder cable (integrated) is connected here. (See page A-39 for details on cables.)
 (*2) After homing, the slider moves to the ME, therefore, please watch for any interference with surrounding objects.
 ME : Mechanical end
 SE : Stroke end
 (*3) Reference position for calculating the moment Ma

Dimensions/Weight by Stroke * Brake-equipped models are heavier by 0.2kg.

L	Stroke	50	100	150	200	250	300
	No Brake	247.5	297.5	347.5	397.5	447.5	497.5
	Brake-Equipped	292	342	392	442	492	542
A		155.5	205.5	255.5	305.5	355.5	405.5
B		84	34	84	34	84	34
C		0	1	1	2	2	3
D		4	6	6	8	8	10
M		84	134	184	234	284	334
Weight (kg)	With Cover	0.7	0.7	0.8	0.9	0.9	1
	No Cover	0.6	0.7	0.7	0.8	0.8	0.9

Compatible Controllers

The RCP3 series actuators can operate with the controllers below. Select the controller according to your usage.

Name	External View	Model	Description	Max. Positioning Points	Input Voltage	Power Supply Capacity	See Page
Solenoid Valve Type		PMEC-C-28PI-NP-2-2	Easy-to-use controller, even for beginners	3 points	AC115V AC230V	See P481	→ P477
		PSEP-C-28PI-NP-2-0	Operable with same signal as solenoid valve. Supports both single and double solenoid types. No homing necessary with simple absolute type.				
Splash-Proof Solenoid Valve Type		PSEP-CW-28PI-NP-2-0					
Positioner Type		PCON-C-28PI-NP-2-0	Positioning is possible for up to 512 points	512 points			
Safety-Compliant Positioner Type		PCON-CG-28PI-NP-2-0					
Pulse Train Input Type (Differential Line Driver)		PCON-PL-28PI-NP-2-0	Pulse train input type with differential line driver support	(-)	DC24V	2A max.	→ P525
Pulse Train Input Type (Open Collector)		PCON-PO-28PI-NP-2-0	Pulse train input type with open collector support				
Serial Communication Type		PCON-SE-28PI-N-0-0	Dedicated to serial communication	64 points			
Field Network Type		RPCON-28P	Dedicated to field network	768 points			→ P503
Program Control Type		PSEL-C-1-28PI-NP-2-0	Programmed operation is possible. Can operate up to 2 axes	1500 points			→ P557

* This is for the single-axis PSEL.

- Slider Type
- Mini
- Standard
- Controllers Integrated
- Rod Type
- Mini
- Standard
- Controllers Integrated
- Table/Arm /Flat Type
- Mini
- Standard
- Gripper/ Rotary Type
- Linear Motor Type
- Cleanroom Type
- Splash-Proof
- Controllers
- PMEC /AMEC
- PSEP /ASEP
- ROBO NET
- ERC2
- PCON
- ACON
- SCON
- PSEL
- ASEL
- SSEL
- XSEL
- Pulse Motor
- Servo Motor (24V)
- Servo Motor (230V)
- Linear Motor

- Slider Type
- Mini
- Standard
- Controllers Integrated
- Rod Type
- Mini
- Standard
- Controllers Integrated
- Table/Arm /Flat Type
- Mini
- Standard
- Gripper/ Rotary Type
- Linear Motor Type
- Cleanroom Type
- Splash-Proof
- Controllers
- PMEC /AMEC
- PSEP /ASEP
- ROBO NET
- ERC2
- PCON
- ACON
- SCON
- PSEL
- ASEL
- SSEL
- XSEL
- Pulse Motor
- Servo Motor (24V)
- Servo Motor (230V)
- Linear Motor

RCP3-SA4C RoboCylinder Slider Type 40mm Width Pulse Motor Coupled

■ Configuration: **RCP3** — **SA4C** — **I** — **35P** — — — — —

Series — Type — Encoder — Motor — Lead — Stroke — Compatible Controllers — Cable Length — Option

I: Incremental 35P: Pulse motor 10: 10mm 50: 50mm P1: PCON N: None See Options below
 * The Simple absolute encoder models are labeled as "I". 35 □ size 5: 5mm 500: 500mm (50mm pitch increments) RPCON P: 1m PSEL S: 3m M: 5m X □ □: Custom Length
 P3: PMECC PSEP

* See page Pre-35 for explanation of each code that make up the configuration name.

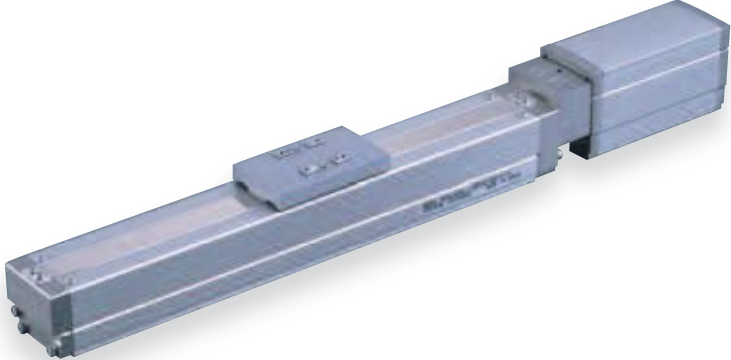

Technical References A-5

POINT Notes on Selection

(1) Since the RCP3 series use a pulse motor, a load capacity decreases at high speeds. Check in the Speed vs. Load Capacity graph to see if your desired speed and load capacity are supported.

(2) The load capacity is based on operation at an acceleration of 0.3G (0.2G for 2.5 mm-lead model, or when used vertically). The maximum acceleration is 0.7G (0.3G when used vertically), however, note that the load capacity decreases at high accelerations. For more information, see the table of load capacity by acceleration, on page A-50.

■ Speed vs. Load Capacity
 Due to the characteristics of the pulse motor, the RCP3 series' load capacity decreases at high speeds. In the table below, check if your desired speed and load capacity are supported.

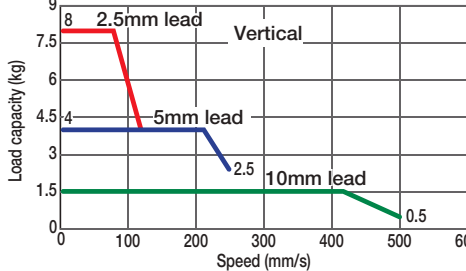
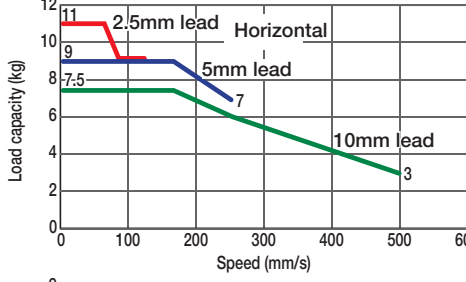

Actuator Specifications						Stroke and Maximum Speed	
■ Lead and Load Capacity						Stroke	
Model	Lead (mm)	Max. Load Capacity		Maximum Push Force (N)	Stroke (mm)	Lead	50 ~ 500 (50mm increments)
		Horizontal (kg)	Vertical (kg)				
RCP3-SA4C-I-35P-10-①-②-③-④	10	~ 7.5	~ 1.5	34	50~500 (50mm increments)	10	500
RCP3-SA4C-I-35P-5-①-②-③-④	5	~ 9	~ 4	68		5	250
RCP3-SA4C-I-35P-2.5-①-②-③-④	2.5	~ 11	~ 8	136		2.5	125

Legend ① Stroke ② Compatible controller ③ Cable length ④ Options (Unit: mm/s)

Type	Cable Symbol
Standard (Robot Cables)	P (1m)
	S (3m)
	M (5m)
Special Lengths	X06 (6m) ~ X10 (10m)
	X11 (11m) ~ X15 (15m)
	X16 (16m) ~ X20 (20m)

* See page A-39 for cables for maintenance.

Name	Option Code	See Page
Brake-Equipped	B	→ A-25
Cable Exit Direction (Top)	CJT	→ A-25
Cable Exit Direction (Right)	CJR	→ A-25
Cable Exit Direction (Left)	CJL	→ A-25
Cable Exit Direction (Bottom)	CJB	→ A-25
No Cover	NCO	→ A-33
Reversed-home	NM	→ A-33

Item	Description
Drive System	Ball screw Ø8mm C10 grade
Positioning Repeatability	±0.02mm
Lost Motion	0.1mm or less
Base	Material: Aluminum (special alumite treated)
Allowable Static Moment	Ma: 6.8N·m Mb: 9.7N·m Mc: 13.3 N·m
Allowable Dynamic Moment(*)	Ma: 3.04N·m Mb: 4.31N·m Mc: 5.00N·m
Overhang Load Length	120mm or less
Ambient Operating Temp./Humidity	0~40°C, 85%RH or less (Non-condensing)

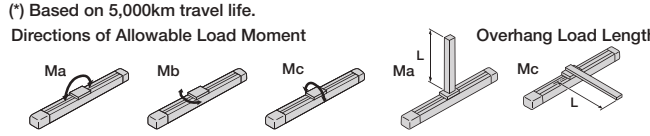

- Slider Type
- Mini
- Standard
- Controllers Integrated
- Rod Type
- Mini
- Standard
- Controllers Integrated
- Table/Arm /Flat Type
- Mini
- Standard
- Gripper/ Rotary Type
- Linear Motor Type
- Cleanroom Type
- Splash-Proof
- Controllers
- PMEC /AMEC
- PSEP /ASEP
- ROBO NET
- ERC2
- PCON
- ACON
- SCON
- PSEL
- ASEL
- SSEL
- XSEL
- Pulse Motor
- Servo Motor (24V)
- Servo Motor (230V)
- Linear Motor

Dimensions

CAD drawings can be downloaded from IAI website. www.robocylinder.de



For Special Order P. A-9

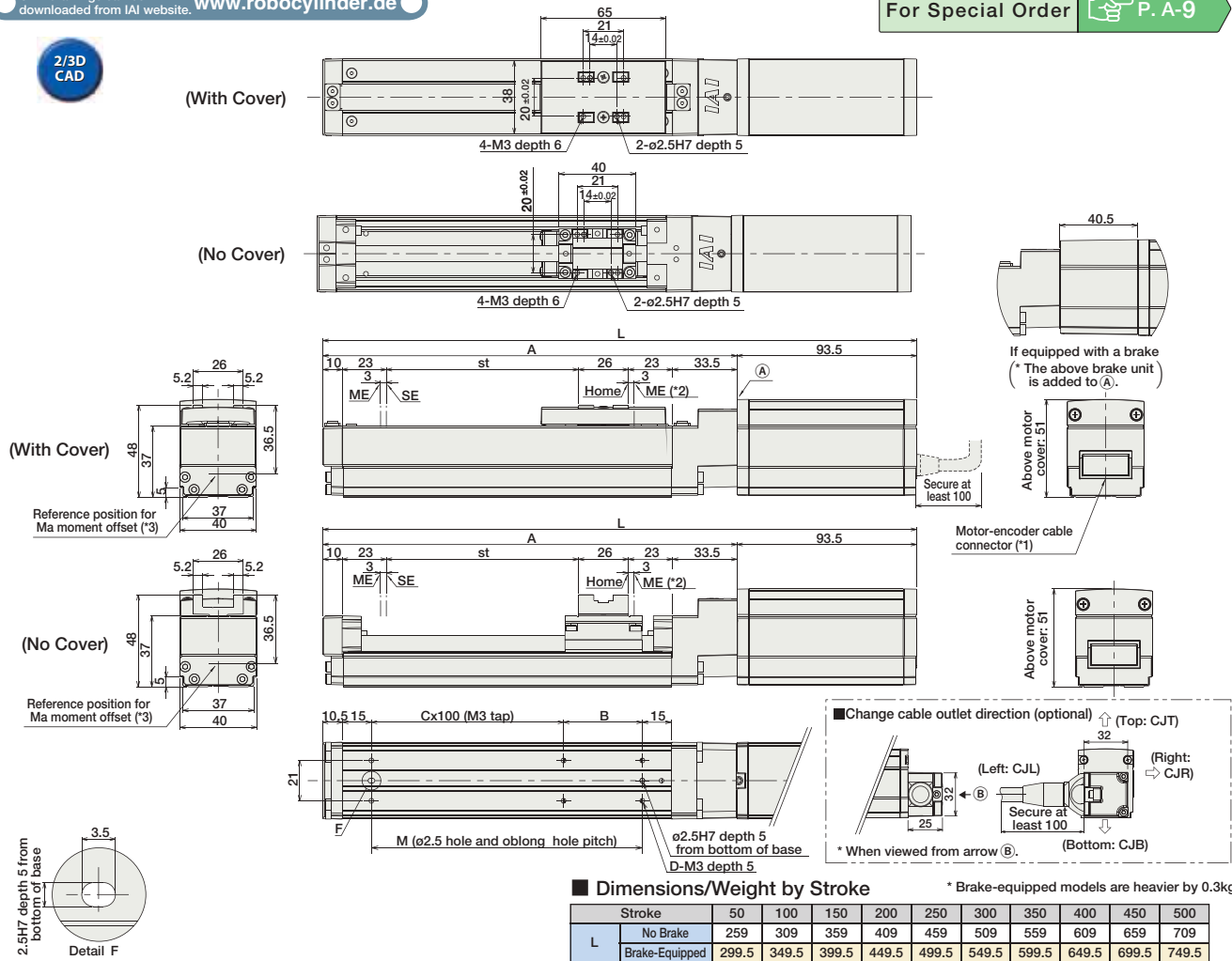

■ Dimensions/Weight by Stroke * Brake-equipped models are heavier by 0.3kg.

Stroke	L	50	100	150	200	250	300	350	400	450	500
		No Brake	259	309	359	409	459	509	559	609	659
Brake-Equipped	299.5	349.5	399.5	449.5	499.5	549.5	599.5	649.5	699.5	749.5	
A	165.5	215.5	265.5	315.5	365.5	415.5	465.5	515.5	565.5	615.5	
B	91	41	91	41	91	41	91	41	91	41	
C	0	1	1	2	2	3	3	4	4	5	
D	4	6	6	8	8	10	10	12	12	14	
M	91	141	191	241	291	341	391	441	491	541	
Weight (kg)	With Cover	0.9	1	1.1	1.2	1.3	1.4	1.5	1.6	1.7	1.8
	No Cover	0.9	0.9	1	1.1	1.2	1.2	1.3	1.4	1.5	1.5

(*1) A Motor-encoder cable (integrated) is connected here. (See page A-39 for details on cables.)
 (*2) After homing, the slider moves to the ME, therefore, please watch for any interference with surrounding objects.
 ME : Mechanical end
 SE : Stroke end
 (*3) Reference position for calculating the moment Ma.

Compatible Controllers

The RCP3 series actuators can operate with the controllers below. Select the controller according to your usage.

Name	External View	Model	Description	Max. Positioning Points	Input Voltage	Power Supply Capacity	See Page
Solenoid Valve Type		PMEC-C-35PI-NP-2-2	Easy-to-use controller, even for beginners	3 points	AC115V AC230V	See P481	→ P477
		PSEP-C-35PI-NP-2-0-H	Operable with same signal as solenoid valve. Supports both single and double solenoid types. No homing necessary with simple absolute type.				
Splash-Proof Solenoid Valve Type		PSEP-CW-35PI-NP-2-0-H					
Positioner Type		PCON-C-35PI-NP-2-0-H	Positioning is possible for up to 512 points	512 points			
Safety-Compliant Positioner Type		PCON-CG-35PI-NP-2-0-H					
Pulse Train Input Type (Differential Line Driver)		PCON-PL-35PI-NP-2-0-H	Pulse train input type with differential line driver support	(-)	DC24V	2A max.	→ P525
Pulse Train Input Type (Open Collector)		PCON-PO-35PI-NP-2-0-H	Pulse train input type with open collector support				
Serial Communication Type		PCON-SE-35PI-N-0-0-H	Dedicated to serial communication	64 points			
Field Network Type		RPCON-35P-H	Dedicated to field network	768 points			→ P503
Program Control Type		PSEL-C-1-35PI-NP-2-0-H	Programmed operation is possible. Can operate up to 2 axes	1500 points			→ P557

* This is for the single-axis PSEL.

- Slider Type
- Mini
- Standard
- Controllers Integrated
- Rod Type
- Mini
- Standard
- Controllers Integrated
- Table/Arm /Flat Type
- Mini
- Standard
- Gripper/ Rotary Type
- Linear Motor Type
- Cleanroom Type
- Splash-Proof
- Controllers
- PMEC /AMEC
- PSEP /ASEP
- ROBO NET
- ERC2
- PCON
- ACON
- SCON
- PSEL
- ASEL
- SSEL
- XSEL
- Pulse Motor
- Servo Motor (24V)
- Servo Motor (230V)
- Linear Motor

RCP3-SA5C RoboCylinder Slider Type 50mm Width Pulse Motor Coupled

■ Configuration: **RCP3** — **SA5C** — **I** — **42P** — — — — —

Series	Type	Encoder	Motor	Lead	Stroke	Compatible Controllers	Cable Length	Option
		I: Incremental * The Simple absolute encoder models are labeled as "I".	42P: Pulse motor 42 □ size	20: 20mm 12: 12mm 6: 6mm 3: 3mm	50: 50mm 800: 800mm (50mm pitch increments)	P1: PCON RPCON PSEL P3: PMEC PSEP	N: None P: 1m S: 3m M: 5m X □ □: Custom Length	See Options below

* See page Pre-35 for explanation of each code that make up the configuration name.

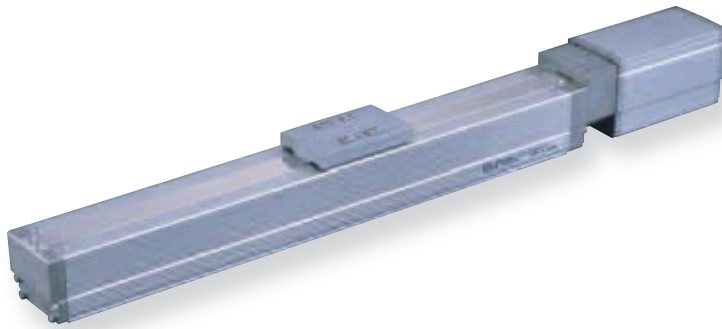

Technical References A-5

- POINT** Notes on Selection
- (1) Since the RCP3 series use a pulse motor, the load capacity decreases at high speeds. Check in the Speed vs. Load Capacity graph to see if your desired speed and load capacity are supported.
 - (2) The load capacity is based on operation at an acceleration of 0.3G (0.2G for 3mm-lead model, or when used vertically). The maximum acceleration is 0.7G (0.3G when used vertically), however, note that the load capacity decreases at high accelerations. For more information, see the table of load capacity by acceleration, on page A-50.

■ Speed vs. Load Capacity
Due to the characteristics of the pulse motor, the RCP3 series' load capacity decreases at high speeds. In the table below, check if your desired speed and load capacity are supported.

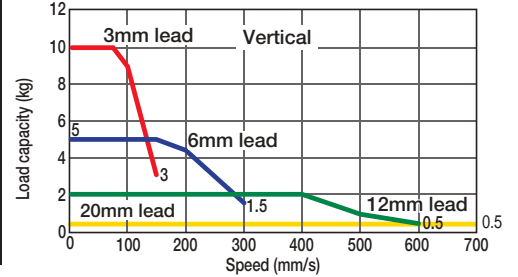
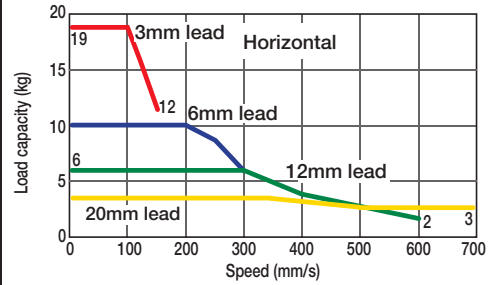

Actuator Specifications

Lead and Load Capacity

Model	Lead (mm)	Max. Load Capacity		Maximum Push Force (N)	Stroke (mm)
		Horizontal (kg)	Vertical (kg)		
RCP3-SA5C-I-42P-20-①-②-③-④	20	~4	~0.5	28	50 ~ 800 (50-mm increments)
RCP3-SA5C-I-42P-12-①-②-③-④	12	~6	~2	47	
RCP3-SA5C-I-42P-6-①-②-③-④	6	~10	~5	95	
RCP3-SA5C-I-42P-3-①-②-③-④	3	~19	~10	189	

Legend ① Stroke ② Compatible controller ③ Cable length ④ Options

Stroke and Maximum Speed

Stroke Lead	50 ~ 550 (50 mm increments)	600 (mm)	650 (mm)	700 (mm)	750 (mm)	800 (mm)
20	1000	1000	910	790	690	610
12	600	570	490	425	370	330
6	300	285	245	210	185	165
3	150	140	120	105	90	80

(Unit: mm/s)

Cable List

Type	Cable Symbol	
Standard (Robot Cables)	P (1m)	
	S (3m)	
	M (5m)	
Special Lengths	X06 (6m) ~ X10 (10m)	
	X11 (11m) ~ X15 (15m)	
	X16 (16m) ~ X20 (20m)	

* See page A-39 for cables for maintenance.

Option List

Name	Option Code	See Page
Brake-Equipped	B	→ A-25
Cable Exit Direction (Top)	CJT	→ A-25
Cable Exit Direction (Right)	CJR	→ A-25
Cable Exit Direction (Left)	CJL	→ A-25
Cable Exit Direction (Bottom)	CJB	→ A-25
No Cover	NCO	→ A-33
Reversed-home	NM	→ A-33

Actuator Specifications

Item	Description
Drive System	Ball screw Ø10mm C10 grade
Positioning Repeatability	±0.02mm
Lost Motion	0.1mm or less
Base	Material: Aluminum (special alumite treated)
Allowable Static Moment	Ma: 10.2N·m Mb: 14.6N·m Mc: 22.4N·m
Allowable Dynamic Moment(*)	Ma: 3.92N·m Mb: 5.58N·m Mc: 8.53N·m
Overhang Load Length	130mm or less
Ambient Operating Temp./Humidity	0~40°C, 85% RH or less (non-condensing)

(*) Based on 5,000km travel life.

Directions of Allowable Load Moment

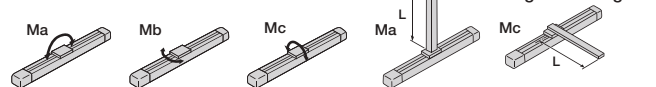

Dimensions

CAD drawings can be downloaded from IAI website. www.robocylinder.de



For Special Order P. A-9

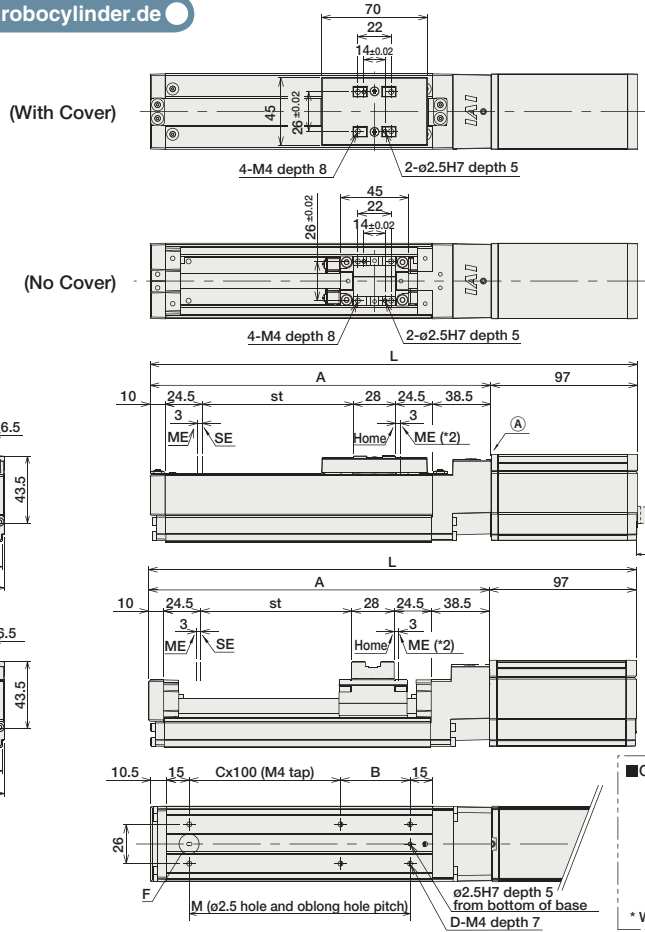
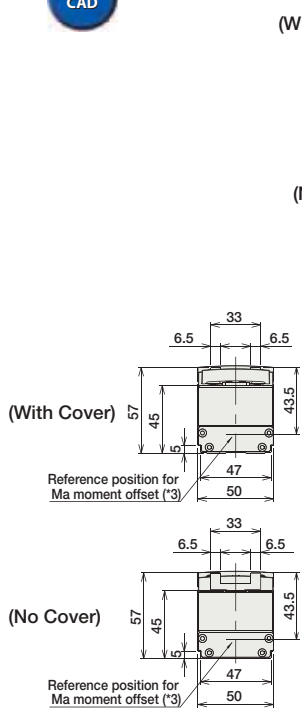

(*1) A motor-encoder cable (integrated) is connected here. (See page A-39 for details on cables.)
(*2) After homing, the slider moves to the ME, therefore, please watch for any interference with surrounding objects.
ME : Mechanical end
SE : Stroke end
(*3) Reference position for calculating the moment Ma

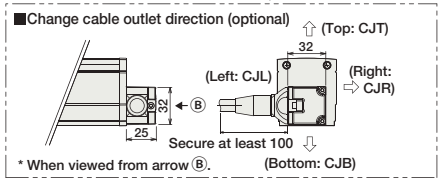
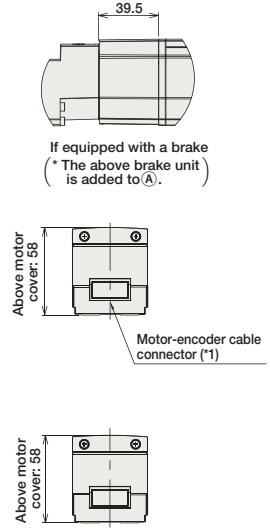

Dimensions/Weight by Stroke * Brake-equipped models are heavier by 0.4kg.

Stroke	50	100	150	200	250	300	350	400	450	500	550	600	650	700	750	800	
L	No Brake	272.5	322.5	372.5	422.5	472.5	522.5	572.5	622.5	672.5	722.5	772.5	822.5	872.5	922.5	972.5	1022.5
	Brake-Equipped	312	362	412	462	512	562	612	662	712	762	812	862	912	962	1012	1062
A	175.5	225.5	275.5	325.5	375.5	425.5	475.5	525.5	575.5	625.5	675.5	725.5	775.5	825.5	875.5	925.5	
B	96	46	96	46	96	46	96	46	96	46	96	46	96	46	96	46	
C	0	1	1	2	2	3	3	4	4	5	5	6	6	7	7	8	
D	4	6	6	8	8	10	10	12	12	14	14	16	16	18	18	20	
M	96	146	196	246	296	346	396	446	496	546	596	646	696	746	796	846	
Weight (kg)	With Cover	1.4	1.5	1.6	1.8	1.9	2	2.2	2.3	2.5	2.6	2.7	2.9	3.0	3.2	3.3	3.4
	No Cover	1.3	1.4	1.5	1.6	1.7	1.8	2	2.1	2.2	2.3	2.4	2.5	2.6	2.8	2.9	3.0

Compatible Controllers

The RCP3 series actuators can operate with the controllers below. Select the controller according to your usage.

Name	External View	Model	Description	Max. Positioning Points	Input Voltage	Power Supply Capacity	See Page
Solenoid Valve Type		PMEC-C-42PI-NP-2-2	Easy-to-use controller, even for beginners	3 points	AC115V AC230V	See P481	→ P477
		PSEP-C-42PI-NP-2-0-H	Operable with same signal as solenoid valve. Supports both single and double solenoid types. No homing necessary with simple absolute type.				
Splash-Proof Solenoid Valve Type		PSEP-CW-42PI-NP-2-0-H					
Positioner Type		PCON-C-42PI-NP-2-0-H	Positioning is possible for up to 512 points	512 points	DC24V	2A max.	→ P525
Safety-Compliant Positioner Type		PCON-CG-42PI-NP-2-0-H					
Pulse Train Input Type (Differential Line Driver)		PCON-PL-42PI-NP-2-0-H	Pulse train input type with differential line driver support	(-)	DC24V	2A max.	→ P525
Pulse Train Input Type (Open Collector)		PCON-PO-42PI-NP-2-0-H	Pulse train input type with open collector support				
Serial Communication Type		PCON-SE-42PI-N-0-0-H	Dedicated to serial communication	64 points			
Field Network Type		RPCON-42P-H	Dedicated to field network	768 points			→ P503
Program Control Type		PSEL-C-1-42PI-NP-2-0-H	Programmed operation is possible. Can operate up to 2 axes	1500 points			→ P557

* This is for the single-axis PSEL.

- Slider Type
- Mini
- Standard
- Controllers Integrated
- Rod Type
- Mini
- Standard
- Controllers Integrated
- Table/Arm /Flat Type
- Mini
- Standard
- Gripper/ Rotary Type
- Linear Motor Type
- Cleanroom Type
- Splash-Proof
- Controllers
- PMEC /AMEC
- PSEP /ASEP
- ROBO NET
- ERC2
- PCON
- ACON
- SCON
- PSEL
- ASEL
- SSEL
- XSEL
- Pulse Motor
- Servo Motor (24V)
- Servo Motor (230V)
- Linear Motor

RCP3-SA6C

RoboCylinder Slider Type 60mm Width Pulse Motor Coupled

■ Configuration: **RCP3** — **SA6C** — **I** — **42P** — — — — —

Series	Type	Encoder	Motor	Lead	Stroke	Compatible Controllers	Cable Length	Option
		I: Incremental * The Simple absolute encoder models are labeled as "I".	42P: Pulse motor 42 □ size	20: 20mm 12: 12mm 6: 6mm 3: 3mm	50: 50mm 800: 800mm (50mm pitch increments)	P1: PCON RCON PSEL P3: PMEC PSEP	N: None P: 1m S: 3m M: 5m X □ □: Custom Length	See Options below

* See page Pre-35 for explanation of each code that make up the configuration name.

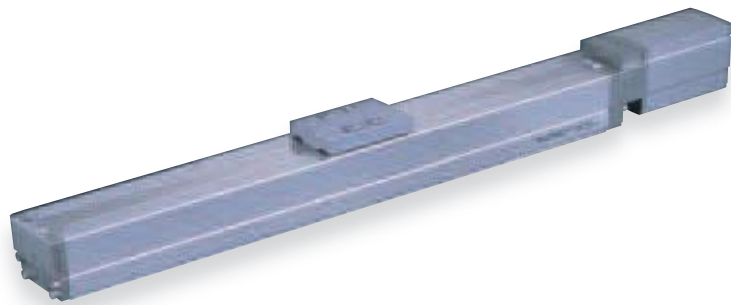

Technical References A-5

- POINT**
Notes on Selection

 - (1) When the stroke increases, the maximum speed will drop to prevent the ball screw from reaching the critical rotational speed. Use the actuator specification table below to check the maximum speed at the stroke you desire.
 - (2) Since the RCP3 series use a pulse motor, the load capacity decreases at high speeds. Check in the Speed vs. Load Capacity graph to see if your desired speed and load capacity are supported.
 - (3) The load capacity is based on operation at an acceleration of 0.3G (0.2G for 3mm lead model and when using vertically). The maximum acceleration is 0.7G (0.3G when used vertically), however, note that the load capacity decreases at high accelerations. For more information, see the table of load capacity by acceleration, on page A-50.

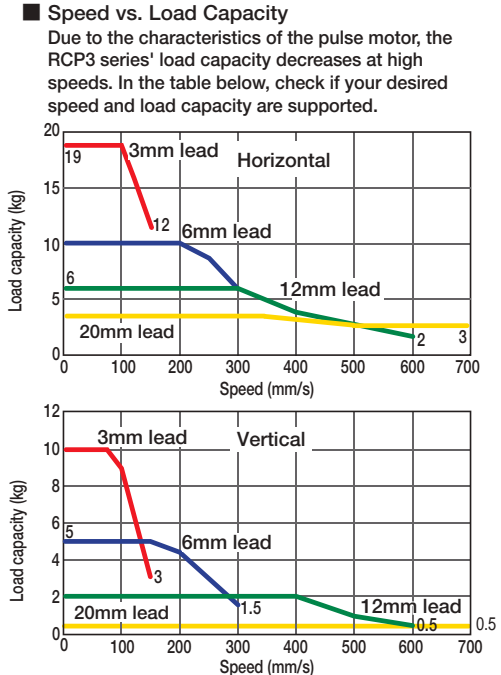

Actuator Specifications					
■ Lead and Load Capacity					
Model	Lead (mm)	Max. Load Capacity		Maximum Push Force (N)	Stroke (mm)
		Horizontal (kg)	Vertical (kg)		
RCP3-SA6C-I-42P-20-①-②-③-④	20	~4	~0.5	28	50 ~ 800 (50-mm increments)
RCP3-SA6C-I-42P-12-①-②-③-④	12	~6	~2	47	
RCP3-SA6C-I-42P-6-①-②-③-④	6	~10	~5	95	
RCP3-SA6C-I-42P-3-①-②-③-④	3	~19	~10	189	

■ Stroke and Maximum Speed							
Stroke Lead	50 ~ 550 (50 mm increments)						
	500	600	650	700	750	800	
20	1000	1000	910	790	690	610	
12	600	570	490	425	370	330	
6	300	285	245	210	185	165	
3	150	140	120	105	90	80	

Legend ① Stroke ② Compatible controller ③ Cable length ④ Options (Unit: mm/s)

Cable List

Type	Cable Symbol
Standard (Robot Cables)	P (1m)
	S (3m)
	M (5m)
Special Lengths	X06 (6m) ~ X10 (10m)
	X11 (11m) ~ X15 (15m)
	X16 (16m) ~ X20 (20m)

* See page A-39 for cables for maintenance.

Actuator Specifications

Item	Description
Drive System	Ball screw Ø10mm C10 grade
Positioning Repeatability	±0.02mm
Lost Motion	0.1mm or less
Base	Material: Aluminum (special alumite treated)
Allowable Static Moment	Ma: 17.6N·m Mb: 25.2N·m Mc: 44.5N·m
Allowable Dynamic Moment(*)	Ma: 4.31N·m Mb: 6.17N·m Mc: 10.98N·m
Overhang Load Length	150mm or less
Ambient Operating Temp./Humidity	0 ~ 40°C, 85% RH or less (non-condensing)

(*) Based on 5,000km travel life.

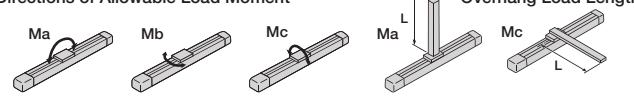

Option List

Name	Option Code	See Page
Brake-Equipped	B	→ A-25
Cable Exit Direction (Top)	CJT	→ A-25
Cable Exit Direction (Right)	CJR	→ A-25
Cable Exit Direction (Left)	CJL	→ A-25
Cable Exit Direction (Bottom)	CJB	→ A-25
No Cover	NCO	→ A-33
Reversed-home	NM	→ A-33

Dimensions

CAD drawings can be downloaded from IAI website. www.robocylinder.de

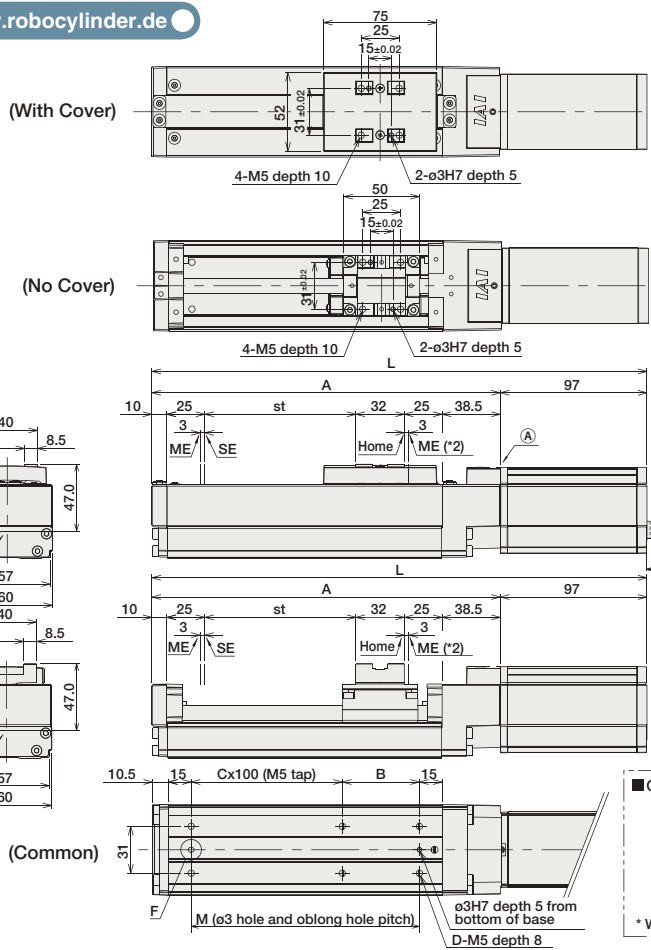

For Special Order P. A-9

- (*1) A motor-encoder cable (integrated) is connected here. (See page A-39 for details on cables.)
- (*2) After homing, the slider moves to the ME, therefore, please watch for any interference with surrounding objects.
ME : Mechanical end
SE : Stroke end
- (*3) Reference position for calculating the moment Ma

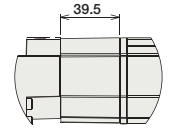

If equipped with a brake (* The above brake unit is added to A.)

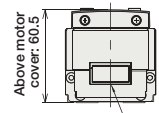

Above motor cover: 60.5
Motor-encoder cable connector (*1)

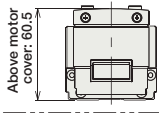

Above motor cover: 60.5

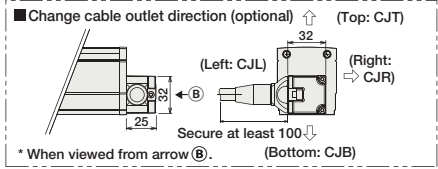

Dimensions/Weight by Stroke * Brake-equipped models are heavier by 0.4kg.

Stroke	Stroke																
	50	100	150	200	250	300	350	400	450	500	550	600	650	700	750	800	
L	No Brake	277.5	327.5	377.5	427.5	477.5	527.5	577.5	627.5	677.5	727.5	777.5	827.5	877.5	927.5	977.5	1027.5
	Brake-Equipped	317	367	417	467	517	567	617	667	717	767	817	867	917	967	1017	1067
A	180.5	230.5	280.5	330.5	380.5	430.5	480.5	530.5	580.5	630.5	680.5	730.5	780.5	830.5	880.5	930.5	
B	101	51	101	51	101	51	101	51	101	51	101	51	101	51	101	51	
C	0	1	1	2	2	3	3	4	4	5	5	6	6	7	7	8	
D	4	6	6	8	8	10	10	12	12	14	14	16	16	18	18	20	
M	101	151	201	251	301	351	401	451	501	551	601	651	701	751	801	851	
Weight (kg)	With Cover	1.6	1.8	2	2.1	2.3	2.5	2.7	2.8	3	3.2	3.3	3.5	3.7	3.9	4.0	4.2
	No Cover	1.5	1.7	1.8	2	2.1	2.3	2.4	2.6	2.7	2.8	3	3.1	3.3	3.4	3.6	3.7

Compatible Controllers

The RCP3 series actuators can operate with the controllers below. Select the controller according to your usage.

Name	External View	Model	Description	Max. Positioning Points	Input Voltage	Power Supply Capacity	See Page
Solenoid Valve Type		PMEC-C-42PI-NP-2-2	Easy-to-use controller, even for beginners	3 points	AC115V AC230V	See P481	→ P477
		PSEP-C-42PI-NP-2-0-H	Operable with same signal as solenoid valve. Supports both single and double solenoid types. No homing necessary with simple absolute type.				
Splash-Proof Solenoid Valve Type		PSEP-CW-42PI-NP-2-0-H					
Positioner Type		PCON-C-42PI-NP-2-0-H	Positioning is possible for up to 512 points	512 points	DC24V	2A max.	
Safety-Compliant Positioner Type		PCON-CG-42PI-NP-2-0-H					
Pulse Train Input Type (Differential Line Driver)		PCON-PL-42PI-NP-2-0-H	Pulse train input type with differential line driver support	(-)	DC24V	2A max.	→ P525
Pulse Train Input Type (Open Collector)		PCON-PO-42PI-NP-2-0-H	Pulse train input type with open collector support				
Serial Communication Type		PCON-SE-42PI-N-0-0-H	Dedicated to serial communication	64 points			
Field Network Type		RPCON-42P-H	Dedicated to field network	768 points			→ P503
Program Control Type		PSEL-C-1-42PI-NP-2-0-H	Programmed operation is possible. Can operate up to 2 axes	1500 points			→ P557

* This is for the single-axis PSEL.

- Slider Type
- Mini
- Standard
- Controllers Integrated
- Rod Type
- Mini
- Standard
- Controllers Integrated
- Table/Arm /Flat Type
- Mini
- Standard
- Gripper/ Rotary Type
- Linear Motor Type
- Cleanroom Type
- Splash-Proof
- Controllers
- PMEC /AMEC
- PSEP /ASEP
- ROBO NET
- ERC2
- PCON
- ACON
- SCON
- PSEL
- ASEL
- SSEL
- XSEL
- Pulse Motor
- Servo Motor (24V)
- Servo Motor (230V)
- Linear Motor

- Slider Type
- Mini
- Standard
- Controllers Integrated
- Rod Type
- Mini
- Standard
- Controllers Integrated
- Table/Arm /Flat Type
- Mini
- Standard
- Gripper/ Rotary Type
- Linear Motor Type
- Cleanroom Type
- Splash-Proof
- Controllers
- PMEC /AMEC
- PSEP /ASEP
- ROBO NET
- ERC2
- PCON
- ACON
- SCON
- PSEL
- ASEL
- SSEL
- XSEL
- Pulse Motor
- Servo Motor (24V)
- Servo Motor (230V)
- Linear Motor

RCP3-SA2AR

RoboCylinder Mini Slider Type Side-Mounted Motor Unit 22mm Width
Pulse Motor Lead Screw

■ Configuration: **RCP3** — **SA2AR** — **I** — **20P** — — — — —

Series	Type	Encoder	Motor	Lead	Stroke	Compatible Controllers	Cable Length	Option
		I: Incremental * The Simple absolute encoder models are labeled as "I".	20P: Pulse motor 20 □ size	4S: 4mm lead screw 2S: 2mm lead screw 1S: 1mm lead screw	25: 25mm 100: 100mm (25mm pitch increments)	P1: PCON RPCON PSEL P3: PMEC PSEP	N: None P: 1m S: 3m M: 5m X □ □: Custom Length	See Options below * Be sure to specify which side the motor is to be mounted (ML/MR).

* See page Pre-35 for explanation of each code that make up the configuration name.

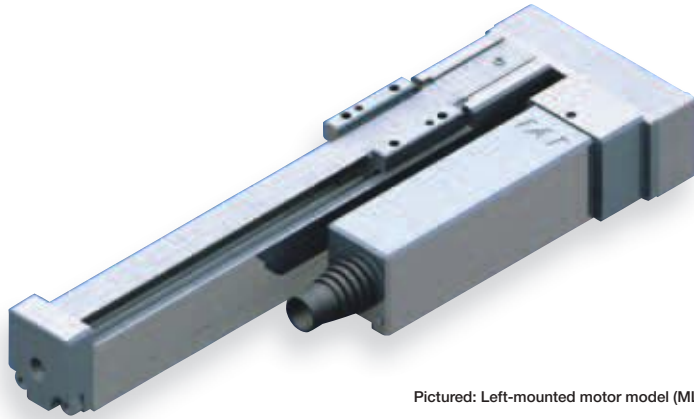

Pictured: Left-mounted motor model (ML).

Technical References A-5

■ Speed vs. Load Capacity
Due to the characteristics of the pulse motor, the RCP3 series' load capacity decreases at high speeds. In the table below, check if your desired speed and load capacity are supported.

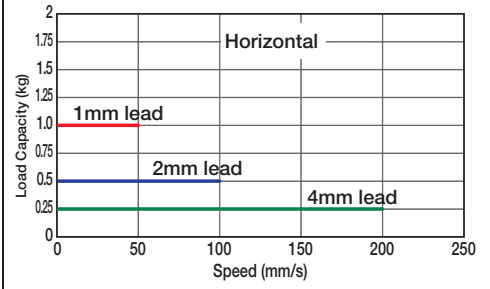

- POINT** Notes on Selection
- (1) The load capacity is based on operation at an acceleration of 0.2G. This is the upper limit for the acceleration.
 - (2) The actuator cannot be used on its side or in a vertical orientation.
 - (3) If used in a dusty environment, the service life will decrease significantly.
 - (4) This model uses a lead screw, therefore please ensure that your usage is appropriate for its characteristics. (See page Pre-42.)

Actuator Specifications							Stroke and Maximum Speed		
■ Lead and Load Capacity							Stroke and Maximum Speed		
Model	Feed Screw	Lead (mm)	Max. Load Capacity		Positioning Repeatability (mm)	Stroke (mm)	Stroke		
			Horizontal (kg)	Vertical (kg)			Lead	25 (mm)	50 ~ 100 (mm)
RCP3-SA2AR-I-20P-4S-①-②-③-④	Lead screw	4	0.25	—	±0.05	25~100 (25mm increments)	4	180	200
RCP3-SA2AR-I-20P-2S-①-②-③-④		2	0.5	—			2	100	
RCP3-SA2AR-I-20P-1S-①-②-③-④		1	1	—			1	50	

Legend ① Stroke ② Compatible controller ③ Cable length ④ Options (Unit: mm/s)

Type	Cable Symbol
Standard (Robot Cables)	P (1m)
	S (3m)
	M (5m)
Special Lengths	X06 (6m) ~ X10 (10m)
	X11 (11m) ~ X15 (15m)
	X16 (16m) ~ X20 (20m)

* The standard cable for the RCP3 is the robot cable.
* See page A-39 for cables for maintenance.

Item	Description
Drive System	Lead screw Ø4mm C10 grade
Lost Motion	0.3mm or less (initial value)
Base	Material: Aluminum (white alumite treated)
Guide	Slide guide
Ambient Operating Temp./Humidity	0~40°C, 85% RH or less (non-condensing)
Service Life	10 million cycles

Option List			
Name	Option Code	See Page	
Left-mounted motor (Standard)	ML	→ A-33	
Right-mounted motor	MR	→ A-33	
Reversed-home	NM	→ A-33	

Dimensions

CAD drawings can be downloaded from IAI website. www.robocylinder.de

For Special Orders A-9

2/3D CAD

- *1 A motor-encoder cable is connected here. See page A-39 for details on cables.
- *2 During the homing operation, the slider moves to actuator's mechanical end; therefore, please watch for any interference with the surrounding objects.

* The diagram below shows a left-mounted motor model.

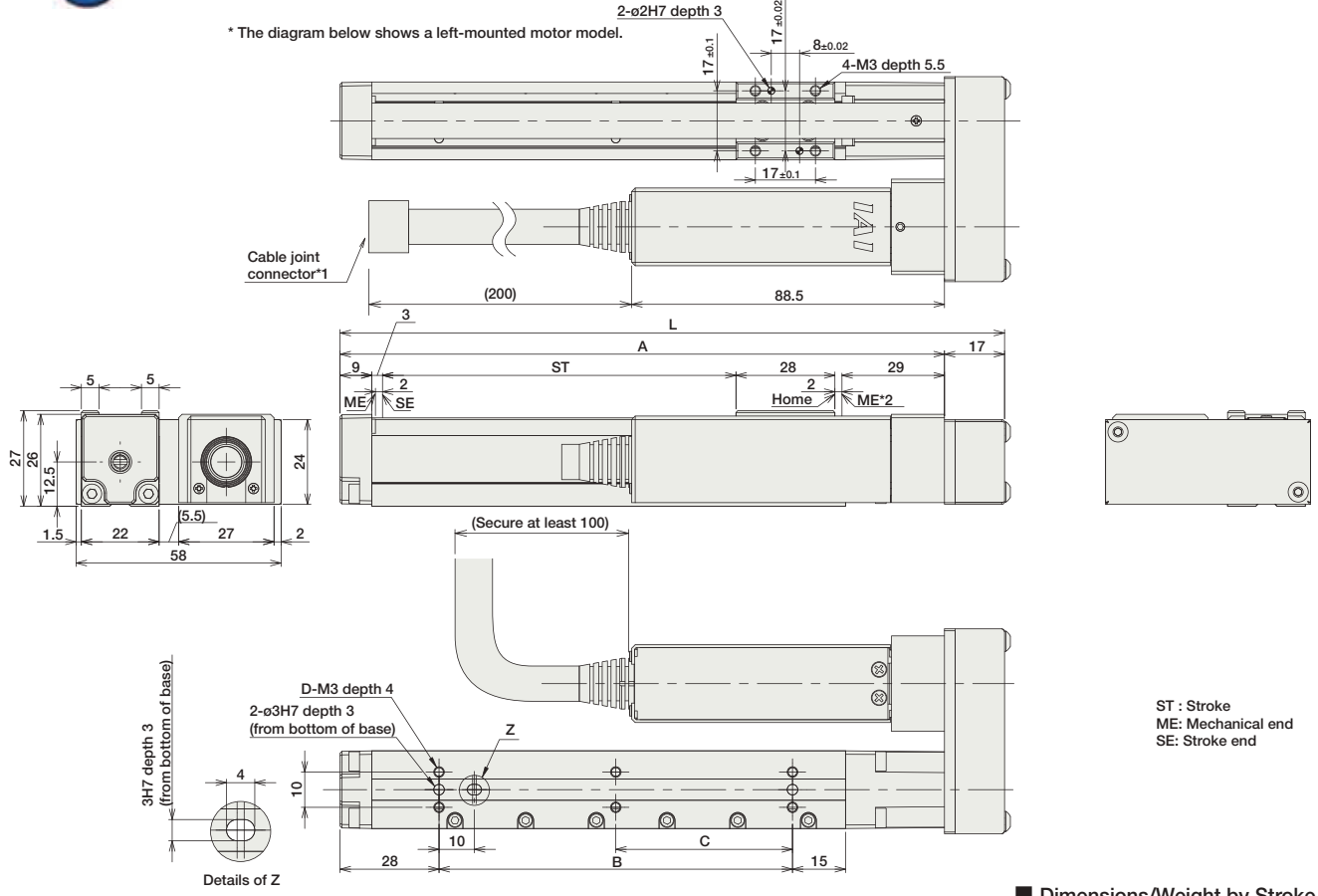

ST : Stroke
ME: Mechanical end
SE: Stroke end

■ Dimensions/Weight by Stroke

Stroke	25	50	75	100
L	113	138	163	188
A	96	121	146	171
B	25	50	75	100
C	0	0	0	50
D	4	4	4	6
Weight (kg)	0.28	0.3	0.32	0.33

Compatible Controllers

The RCP3 series actuators can operate with the controllers below. Select the controller according to your usage.

Name	External View	Model	Description	Max. Positioning Points	Input Voltage	Power Supply Capacity	See Page
Solenoid Valve Type		PMEC-C-20PI-NP-2-2	Easy-to-use controller, even for beginners	3 points	AC115V AC230V	See P481	→ P477
Splash-Proof Solenoid Valve Type		PSEP-C-20PI-NP-2-0	Operable with same signal as solenoid valve. Supports both single and double solenoid types. No homing necessary with simple absolute type.				
Positioner Type		PCON-C-20PI-NP-2-0	Positioning is possible for up to 512 points	512 points	DC24V	2A max.	
Safety-Compliant Positioner Type		PCON-CG-20PI-NP-2-0					
Pulse Train Input Type (Differential Line Driver)		PCON-PL-20PI-NP-2-0	Pulse train input type with differential line driver support	(-)	DC24V	2A max.	→ P525
Pulse Train Input Type (Open Collector)		PCON-PO-20PI-NP-2-0	Pulse train input type with open collector support				
Serial Communication Type		PCON-SE-20PI-N-0-0	Dedicated to serial communication	64 points			
Field Network Type		RPCON-20P	Dedicated to field network	768 points			→ P503
Program Control Type		PSEL-C-1-20PI-NP-2-0	Programmed operation is possible. Can operate up to 2 axes	1500 points			→ P557

* This is for the single-axis PSEL.

- Slider Type
- Mini
- Standard
- Controllers Integrated
- Rod Type
- Mini
- Standard
- Controllers Integrated
- Table/Arm /Flat Type
- Mini
- Standard
- Gripper/ Rotary Type
- Linear Motor Type
- Cleanroom Type
- Splash-Proof
- Controllers
- PMEC /AMEC
- PSEP /ASEP
- ROBO NET
- ERC2
- PCON
- ACON
- SCON
- PSEL
- ASEL
- SSEL
- XSEL
- Pulse Motor
- Servo Motor (24V)
- Servo Motor (230V)
- Linear Motor

- Slider Type
- Mini
- Standard
- Controllers Integrated
- Rod Type
- Mini
- Standard
- Controllers Integrated
- Table/Arm /Flat Type
- Mini
- Standard
- Gripper/ Rotary Type
- Linear Motor Type
- Cleanroom Type
- Splash-Proof
- Controllers
- PMEC /AMEC
- PSEP /ASEP
- ROBO NET
- ERC2
- PCON
- ACON
- SCON
- PSEL
- ASEL
- SSEL
- XSEL
- Pulse Motor
- Servo Motor (24V)
- Servo Motor (230V)
- Linear Motor

RCP3-SA2BR

RoboCylinder Mini Slider Type Side-Mounted Motor Unit 28mm Width
Pulse Motor Lead Screw

■ Configuration: **RCP3** — **SA2BR** — **I** — **20P** — — — — —

Series	Type	Encoder	Motor	Lead	Stroke	Compatible Controllers	Cable Length	Option
		I: Incremental * The Simple absolute encoder models are labeled as "I".	20P: Pulse motor 20 □ size	6S: 4mm lead screw 4S: 4mm lead screw 2S: 2mm lead screw	25: 25mm 25: 25mm 150: 150mm (25mm pitch increments)	P1: PCON RPCON PSEL P3: PMECP PSEP	N: None P: 1m S: 3m M: 5m X □ □: Custom Length	See Options below * Be sure to specify which side the motor is to be mounted (ML/MR).

* See page Pre-35 for explanation of each code that make up the configuration name.

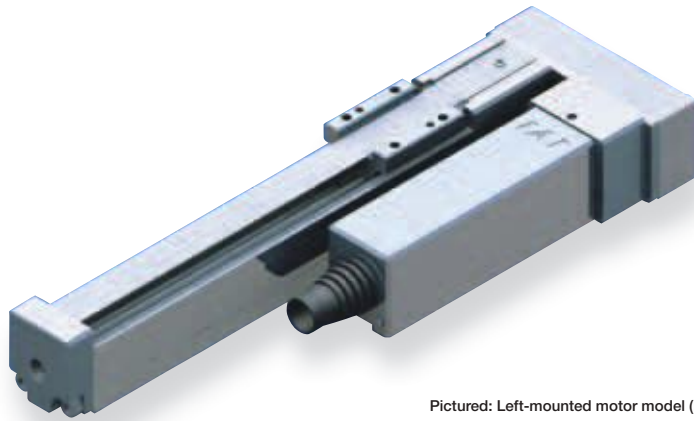

Pictured: Left-mounted motor model (ML).

Technical References A-5

■ Speed vs. Load Capacity
Due to the characteristics of the pulse motor, the RCP3 series' load capacity decreases at high speeds. In the table below, check if your desired speed and load capacity are supported.

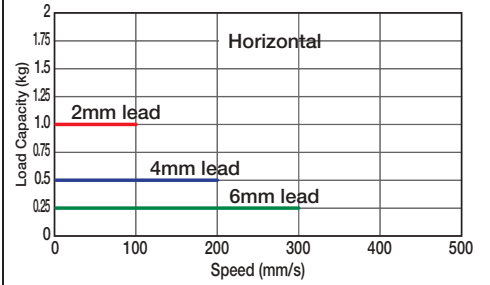

- POINT** Notes on Selection
- (1) The load capacity is based on operation at an acceleration of 0.2G. This is the upper limit for the acceleration.
 - (2) The actuator cannot be used on its side or in a vertical orientation.
 - (3) If used in a dusty environment, the service life will decrease significantly.
 - (4) This model uses a lead screw, therefore please ensure that your usage is appropriate for its characteristics. (See page Pre-42.)

Actuator Specifications							Stroke and Maximum Speed				
■ Lead and Load Capacity											
Model	Feed Screw	Lead (mm)	Max. Load Capacity		Positioning Repeatability (mm)	Stroke (mm)	Stroke				
			Horizontal (kg)	Vertical (kg)			Lead	25 (mm)	50 (mm)	75~150 (mm)	
RCP3-SA2BR-I-20P-6S-①-②-③-④	Lead screw	6	0.25	—	±0.05	25~150 (25mm increments)	6	180	280	300	
RCP3-SA2BR-I-20P-4S-①-②-③-④		4	0.5	—			4	180	200		
RCP3-SA2BR-I-20P-2S-①-②-③-④		2	1	—			2	100			

Legend ① Stroke ② Compatible controller ③ Cable length ④ Options (Unit: mm/s)

Type	Cable Symbol	
Standard (Robot Cables)	P (1m)	
	S (3m)	
	M (5m)	
Special Lengths	X06 (6m) ~ X10 (10m)	
	X11 (11m) ~ X15 (15m)	
	X16 (16m) ~ X20 (20m)	

* The standard cable for the RCP3 is the robot cable.
* See page A-39 for cables for maintenance.

Item	Description
Drive System	Lead screw ø6mm C10 grade
Lost Motion	0.3mm or less (initial value)
Base	Material: Aluminum (white alumite treated)
Guide	Slide guide
Ambient Operating Temp./Humidity	0~40°C, 85% RH or less (non-condensing)
Service Life	10 million cycles

Name	Option Code	See Page
Left-Mounted Motor (Standard)	ML	→ A-33
Right-Mounted Motor	MR	→ A-33
Reversed-home	NM	→ A-33

Dimensions

CAD drawings can be downloaded from IAI website. www.robocylinder.de

For Special Orders A-9



* The diagram below shows a left-mounted motor model.

- *1 A motor-encoder cable is connected here. See page A-39 for details on cables.
- *2 During the homing operation, the slider moves to actuator's mechanical end; therefore, please watch for any interference with the surrounding objects.

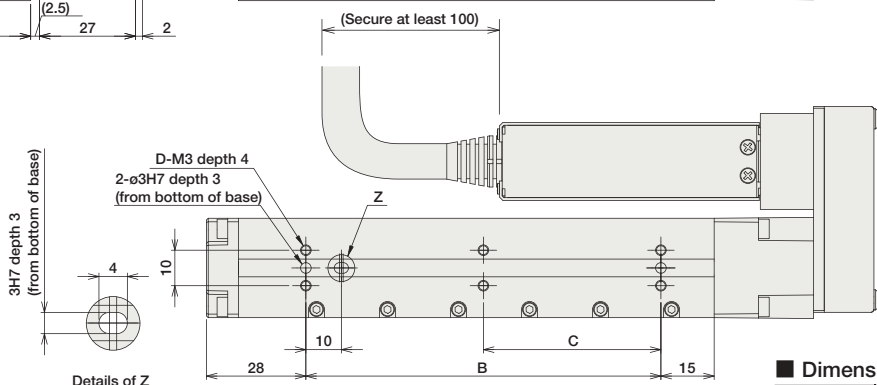
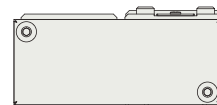
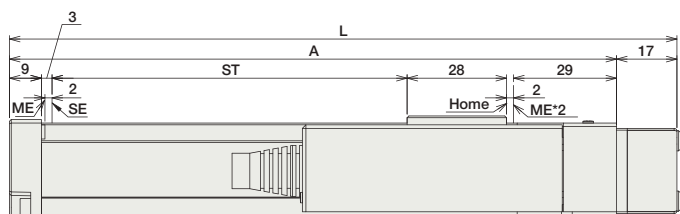
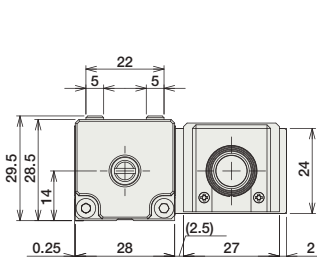
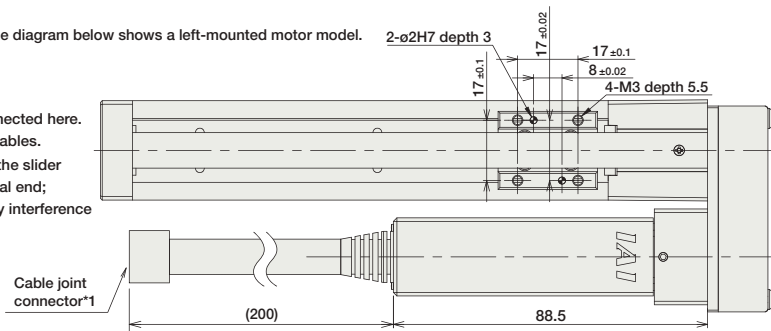

ST : Stroke
ME: Mechanical end
SE: Stroke end

Dimensions/Weight by Stroke

Stroke	25	50	75	100	125	150
L	113	138	163	188	213	238
A	96	121	146	171	196	221
B	25	50	75	100	125	150
C	0	0	0	50	62.5	75
D	4	4	4	6	6	6
Weight (kg)	0.32	0.34	0.37	0.39	0.42	0.46

Compatible Controllers

The RCP3 series actuators can operate with the controllers below. Select the controller according to your usage.

Name	External View	Model	Description	Max. Positioning Points	Input Voltage	Power Supply Capacity	See Page
Solenoid Valve Type		PMEC-C-20PI-NP-2-2	Easy-to-use controller, even for beginners	3 points	AC115V AC230V	See P481	→ P477
		PSEP-C-20PI-NP-2-0	Operable with same signal as solenoid valve. Supports both single and double solenoid types. No homing necessary with simple absolute type.				
Splash-Proof Solenoid Valve Type		PSEP-CW-20PI-NP-2-0					→ P487
Positioner Type		PCON-C-20PI-NP-2-0	Positioning is possible for up to 512 points	512 points			
Safety-Compliant Positioner Type		PCON-CG-20PI-NP-2-0					
Pulse Train Input Type (Differential Line Driver)		PCON-PL-20PI-NP-2-0	Pulse train input type with differential line driver support	(-)	DC24V	2A max.	→ P525
Pulse Train Input Type (Open Collector)		PCON-PO-20PI-NP-2-0	Pulse train input type with open collector support				
Serial Communication Type		PCON-SE-20PI-N-0-0	Dedicated to serial communication	64 points			
Field Network Type		RPCON-20P	Dedicated to field network	768 points			→ P503
Program Control Type		PSEL-C-1-20PI-NP-2-0	Programmed operation is possible. Can operate up to 2 axes	1500 points			→ P557

* This is for the single-axis PSEL.

- Slider Type
- Mini
- Standard
- Controllers Integrated
- Rod Type
- Mini
- Standard
- Controllers Integrated
- Table/Arm /Flat Type
- Mini
- Standard
- Gripper/ Rotary Type
- Linear Motor Type
- Cleanroom Type
- Splash-Proof
- Controllers
- PMEC /AMEC
- PSEP /ASEP
- ROBO NET
- ERC2
- PCON
- ACON
- SCON
- PSEL
- ASEL
- SSEL
- XSEL
- Pulse Motor
- Servo Motor (24V)
- Servo Motor (230V)
- Linear Motor

- Slider Type
- Mini
- Standard
- Controllers Integrated
- Rod Type
- Mini
- Standard
- Controllers Integrated
- Table/Arm /Flat Type
- Mini
- Standard
- Gripper/ Rotary Type
- Linear Motor Type
- Cleanroom Type
- Splash-Proof
- Controllers
- PMEC /AMEC
- PSEP /ASEP
- ROBO NET
- ERC2
- PCON
- ACON
- SCON
- PSEL
- ASEL
- SSEL
- XSEL
- Pulse Motor
- Servo Motor (24V)
- Servo Motor (230V)
- Linear Motor

RCP3-SA3R RoboCylinder Slider Type 32mm Width Pulse Motor Side-Mounted Motor

■ Configuration: **RCP3** — **SA3R** — **I** — **28P** — — — — —

Series	Type	Encoder	Motor	Lead	Stroke	Compatible Controllers	Cable Length	Option
		I: Incremental * The Simple absolute encoder models are labeled as "I".	28P: Pulse motor 28 □ size	6 : 4mm 4 : 4mm 2 : 2mm	50: 50mm 300: 300mm (50mm pitch increments)	P1: PCON RPCON PSEL P3: PMECC PSEP	N : None P : 1m S : 3m M : 5m X □ □ : Custom Length	See Options below * Be sure to specify which side the motor is to be mounted (ML/MR).

* See page Pre-35 for explanation of each code that make up the configuration name.



Technical References A-5

POINT Notes on Selection

(1) Since the RCP3 series use a pulse motor, the load capacity decreases at high speeds. Check in the Speed vs. Load Capacity graph to see if your desired speed and load capacity are supported.

(2) The load capacity is based on operation at an acceleration of 0.3G (0.2G for the 2mm-lead model, or when used vertically). These values are the upper limits for the acceleration.

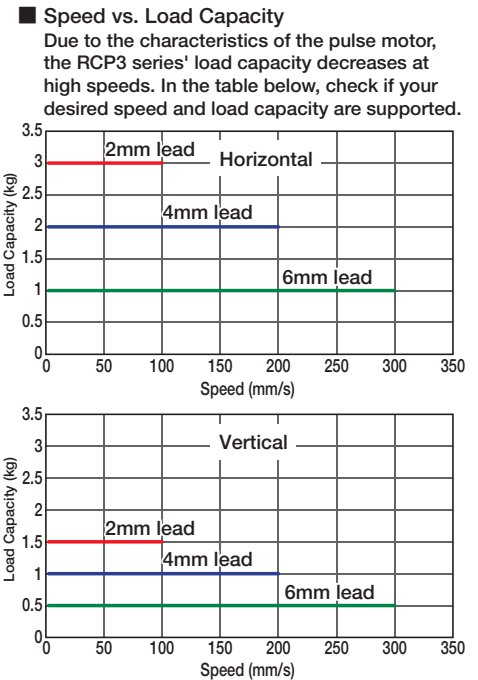

Actuator Specifications					Stroke and Maximum Speed	
■ Lead and Load Capacity					Stroke	
Model	Lead (mm)	Max. Load Capacity		Maximum Push Force (N)	Stroke (mm)	50 ~ 300 (50mm increments)
		Horizontal (kg)	Vertical (kg)			
RCP3-SA3R-I-28P-6-①-②-③-④	6	1	0.5	15	50~300 (50mm increments)	300
RCP3-SA3R-I-28P-4-①-②-③-④	4	2	1	22		200
RCP3-SA3R-I-28P-2-①-②-③-④	2	3	1.5	44		100

Legend ① Stroke ② Compatible controller ③ Cable length ④ Options (Unit: mm/s)

Cable List

Type	Cable Symbol
Standard (Robot Cables)	P (1m)
	S (3m)
	M (5m)
Special Lengths	X06 (6m) ~ X10 (10m)
	X11 (11m) ~ X15 (15m)
	X16 (16m) ~ X20 (20m)

* The standard cable is the motor-encoder integrated robot cable.
* See page A-39 for cables for maintenance.

Option List

Name	Option Code	See Page
Brake-Equipped	B	→ A-25
Cable Exit Direction (Top)	CJT	→ A-25
Cable Exit Direction (Outside)	CJO	→ A-25
Cable Exit Direction (Bottom)	CJB	→ A-25
Left-Mounted Motor (Standard)	ML	→ A-33
Right-Mounted Motor	MR	→ A-33
No Cover	NCO	→ A-33
Reversed-home	NM	→ A-33

Actuator Specifications

Item	Description
Drive System	Ball screw Ø6mm C10 grade
Positioning Repeatability	±0.02mm
Lost Motion	0.1mm or less
Base	Material: Aluminum (special alumite treated)
Allowable Static Load Moment	Ma: 5.0N·m Mb: 7.1N·m Mc: 7.9N·m
Allowable Dynamic Load Moment	Ma: 1.96N·m Mb: 2.84N·m Mc: 3.14N·m
Overhang Load Length	100mm or less
Ambient Operating Temp./Humidity	0~40°C, 85% RH or less (non-condensing)

Directions of Allowable Load Moment

Overhang Load Length

5,000 km service life

Dimensions

CAD drawings can be downloaded from IAI website. www.robocylinder.de



For Special Orders A-9

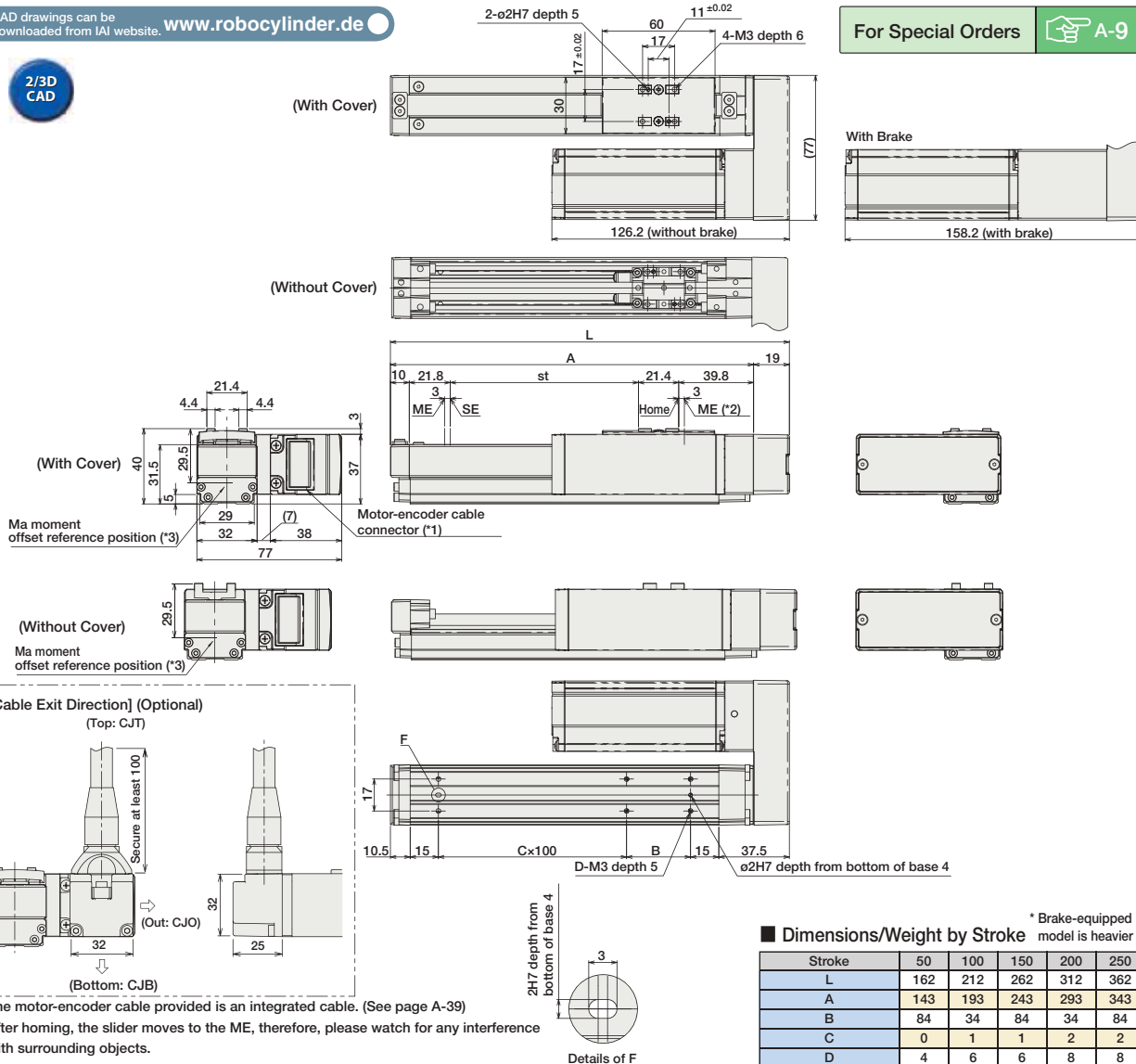

■ Dimensions/Weight by Stroke * Brake-equipped model is heavier by 0.2kg.

Stroke	50	100	150	200	250	300
L	162	212	262	312	362	412
A	143	193	243	293	343	393
B	84	34	84	34	84	34
C	0	1	1	2	2	3
D	4	6	6	8	8	10
Weight (kg)	With Cover	0.8	0.8	0.9	1.0	1.0
	No Cover	0.7	0.8	0.8	0.9	0.9

(*1) The motor-encoder cable provided is an integrated cable. (See page A-39)
 (*2) After homing, the slider moves to the ME, therefore, please watch for any interference with surrounding objects.
 ME : Mechanical end
 SE : Stroke end
 (*3) Reference position for calculating the moment Ma

Compatible Controllers

The RCP3 series actuators can operate with the controllers below. Select the controller according to your usage.

Name	External View	Model	Description	Max. Positioning Points	Input Voltage	Power Supply Capacity	See Page
Solenoid Valve Type		PMEC-C-28PI-NP-2-2	Easy-to-use controller, even for beginners	3 points	AC115V AC230V	See P461	→ P477
		PSEP-C-28PI-NP-2-0	Operable with same signal as solenoid valve. Supports both single and double solenoid types. No homing necessary with simple absolute type.				
Splash-Proof Solenoid Valve Type		PSEP-CW-28PI-NP-2-0					
Positioner Type		PCON-C-28PI-NP-2-0	Positioning is possible for up to 512 points	512 points	DC24V	2A max.	
Safety-Compliant Positioner Type		PCON-CG-28PI-NP-2-0					
Pulse Train Input Type (Differential Line Driver)		PCON-PL-28PI-NP-2-0	Pulse train input type with differential line driver support	(-)	DC24V	2A max.	→ P525
Pulse Train Input Type (Open Collector)		PCON-PO-28PI-NP-2-0	Pulse train input type with open collector support				
Serial Communication Type		PCON-SE-28PI-N-0-0	Dedicated to serial communication	64 points			
Field Network Type		RPCON-28P	Dedicated to field network	768 points			→ P503
Program Control Type		PSEL-C-1-28PI-NP-2-0	Programmed operation is possible. Can operate up to 2 axes	1500 points			→ P557

* This is for the single-axis PSEL.

- Slider Type
- Mini
- Standard
- Controllers Integrated
- Rod Type
- Mini
- Standard
- Controllers Integrated
- Table/Arm /Flat Type
- Mini
- Standard
- Gripper/ Rotary Type
- Linear Motor Type
- Cleanroom Type
- Splash-Proof
- Controllers
- PMEC /AMEC
- PSEP /ASEP
- ROBO NET
- ERC2
- PCON
- ACON
- SCON
- PSEL
- ASEL
- SSEL
- XSEL
- Pulse Motor
- Servo Motor (24V)
- Servo Motor (230V)
- Linear Motor

RCP3-SA4R RoboCylinder Slider Type 40mm Width Pulse Motor Side-Mounted Motor

Configuration: RCP3 - SA4R - I - 35P

Series	Type	Encoder	Motor	Lead	Stroke	Compatible Controllers	Cable Length	Option
		I: Incremental * The Simple absolute encoder models are labeled as "I".	35P: Pulse motor 35 □ size	10 : 10mm 5 : 5mm 2.5 : 2.5mm	50: 50mm 500: 500mm (50mm pitch increments)	P1: PCON RPCON PSEL P3: PMECC PSEP	N : None P : 1m S : 3m M : 5m X □ □ : Custom Length	See Options below * Be sure to specify which side the motor is to be mounted (ML/MR).

* See page Pre-35 for explanation of each code that make up the configuration name.

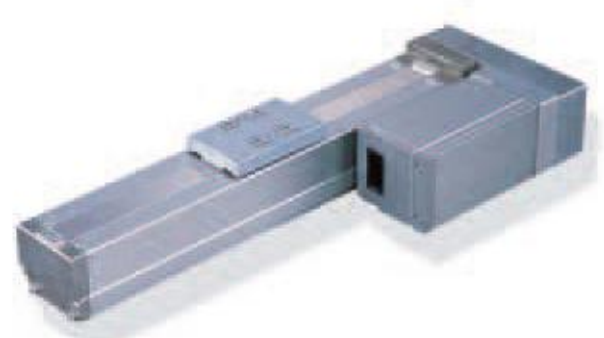

Technical References A-5

POINT Notes on Selection

- (1) Since the RCP3 series use a pulse motor, the load capacity decreases at high speeds. Check in the Speed vs. Load Capacity graph to see if your desired speed and load capacity are supported.
- (2) The load capacity is based on operation at an acceleration of 0.3G (0.2G for the 2.5mm-lead model, or when used vertically). These values are the upper limits for the acceleration.

Speed vs. Load Capacity
Due to the characteristics of the pulse motor, the RCP3 series' load capacity decreases at high speeds. In the table below, check if your desired speed and load capacity are supported.

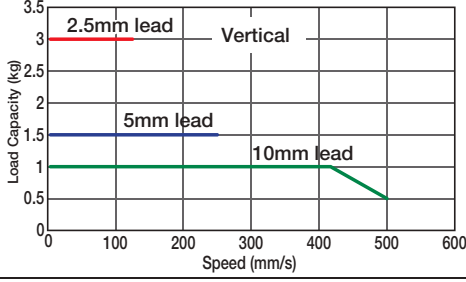
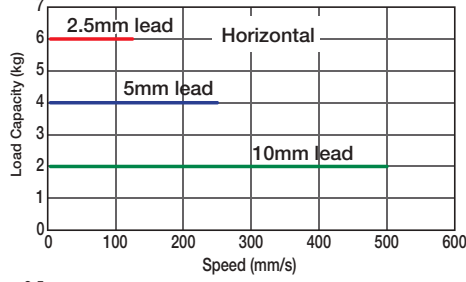

Actuator Specifications						Stroke and Maximum Speed	
Lead and Load Capacity						Stroke (mm)	50 ~ 500 (50mm increments)
Model	Lead (mm)	Max. Load Capacity		Maximum Push Force (N)	Lead		
		Horizontal (kg)	Vertical (kg)				
RCP3-SA4R-I-35P-10-①-②-③-④	10	2	~ 1	34	50~500 (50mm increments)	10	500
RCP3-SA4R-I-35P-5-①-②-③-④	5	4	1.5	68		5	250
RCP3-SA4R-I-35P-2.5-①-②-③-④	2.5	6	3	136		2.5	125

Legend ① Stroke ② Compatible controller ③ Cable length ④ Options (Unit: mm/s)

Type	Cable Symbol
Standard (Robot Cables)	P (1m)
	S (3m)
	M (5m)
Special Lengths	X06 (6m) ~ X10 (10m)
	X11 (11m) ~ X15 (15m)
	X16 (16m) ~ X20 (20m)

* The standard cable is the motor-encoder integrated robot cable.
* See page A-39 for cables for maintenance.

Name	Option Code	See Page
Brake-Equipped	B	→ A-25
Cable Exit Direction (Top)	CJT	→ A-25
Cable Exit Direction (Outside)	CJO	→ A-25
Cable Exit Direction (Bottom)	CJB	→ A-25
Left-Mounted Motor (Standard)	ML	→ A-33
Right-Mounted Motor	MR	→ A-33
No Cover	NCO	→ A-33
Reversed-home	NM	→ A-33

Item	Description
Drive System	Ball screw Ø8mm C10 grade
Positioning Repeatability	±0.02mm
Lost Motion	0.1mm or less
Base	Material: Aluminum (special alumite treated)
Allowable Static Load Moment	Ma: 6.8N·m Mb: 9.7N·m Mc: 13.3N·m
Allowable Dynamic Load Moment	Ma: 3.04N·m Mb: 4.31N·m Mc: 5.00N·m
Overhang Load Length	120mm or less
Ambient Operating Temp./Humidity	0~40°C, 85% RH or less (non-condensing)

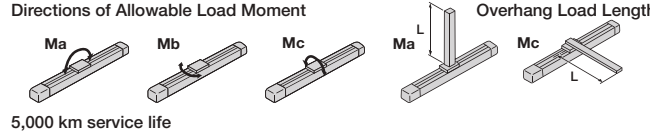

Dimensions

CAD drawings can be downloaded from IAI website. www.robocylinder.de



For Special Orders A-9

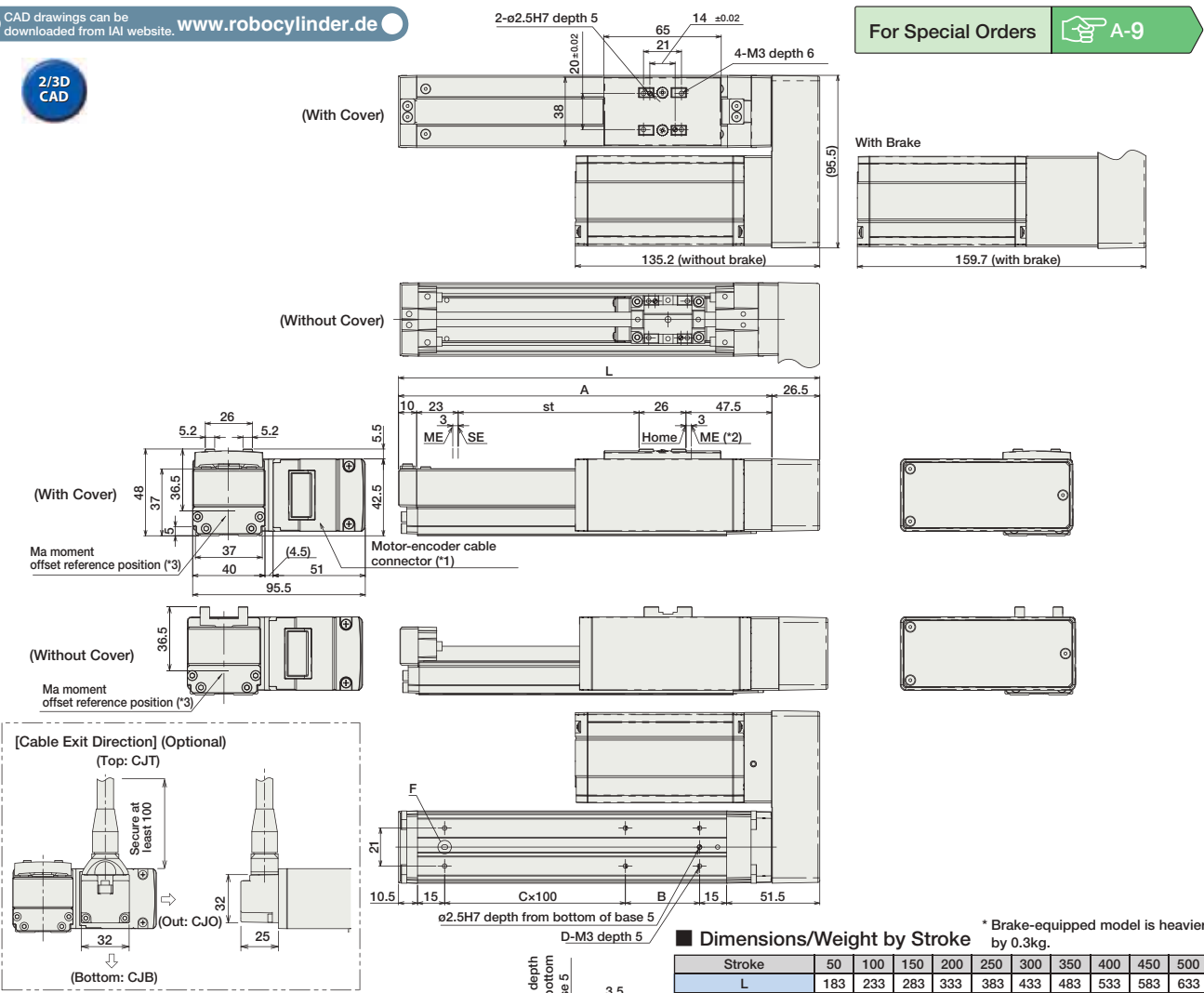

(*) The motor-encoder cable provided is an integrated cable. (See page A-39)
 (**) After homing, the slider moves to the ME, therefore, please watch for any interference with surrounding objects.
 ME : Mechanical end
 SE : Stroke end
 (***) Reference position for calculating the moment Ma

Dimensions/Weight by Stroke * Brake-equipped model is heavier by 0.3kg.

Stroke	50	100	150	200	250	300	350	400	450	500
L	183	233	283	333	383	433	483	533	583	633
A	156.5	206.5	256.5	306.5	356.5	406.5	456.5	506.5	556.5	606.5
B	91	41	91	41	91	41	91	41	91	41
C	0	1	1	2	2	3	3	4	4	5
D	4	6	6	8	8	10	10	12	12	14
Weight (kg)	With Cover	1.1	1.2	1.3	1.4	1.5	1.6	1.7	1.8	1.9
	No Cover	1.1	1.1	1.2	1.3	1.4	1.4	1.5	1.6	1.7

Compatible Controllers

The RCP3 series actuators can operate with the controllers below. Select the controller according to your usage.

Name	External View	Model	Description	Max. Positioning Points	Input Voltage	Power Supply Capacity	See Page	
Solenoid Valve Type		PMEC-C-35PI-NP-2-2	Easy-to-use controller, even for beginners	3 points	AC115V AC230V	See P481	→ P477	
		PSEP-C-35PI-NP-2-0	Operable with same signal as solenoid valve. Supports both single and double solenoid types. No homing necessary with simple absolute type.					
Splash-Proof Solenoid Valve Type		PSEP-CW-35PI-NP-2-0					→ P487	
Positioner Type		PCON-C-35PI-NP-2-0	Positioning is possible for up to 512 points	512 points	DC24V	2A max.		
Safety-Compliant Positioner Type		PCON-CG-35PI-NP-2-0						
Pulse Train Input Type (Differential Line Driver)		PCON-PL-35PI-NP-2-0	Pulse train input type with differential line driver support	(-)				→ P525
Pulse Train Input Type (Open Collector)		PCON-PO-35PI-NP-2-0	Pulse train input type with open collector support					
Serial Communication Type		PCON-SE-35PI-N-0-0	Dedicated to serial communication	64 points				
Field Network Type		RPCON-35P	Dedicated to field network	768 points				→ P503
Program Control Type		PSEL-C-1-35PI-NP-2-0	Programmed operation is possible Can operate up to 2 axes	1500 points				→ P567

* This is for the single-axis PSEL.

- Slider Type
- Mini
- Standard
- Controllers Integrated
- Rod Type
- Mini
- Standard
- Controllers Integrated
- Table/Arm /Flat Type
- Mini
- Standard
- Gripper/ Rotary Type
- Linear Motor Type
- Cleanroom Type
- Splash-Proof
- Controllers
- PMEC /AMEC
- PSEP /ASEP
- ROBO NET
- ERC2
- PCON
- ACON
- SCON
- PSEL
- ASEL
- SSEL
- XSEL
- Pulse Motor
- Servo Motor (24V)
- Servo Motor (230V)
- Linear Motor

- Slider Type
- Mini
- Standard
- Controllers Integrated
- Rod Type
- Mini
- Standard
- Controllers Integrated
- Table/Arm /Flat Type
- Mini
- Standard
- Gripper/ Rotary Type
- Linear Motor Type
- Cleanroom Type
- Splash-Proof
- Controllers
- PMEC /AMEC
- PSEP /ASEP
- ROBO NET
- ERC2
- PCON
- ACON
- SCON
- PSEL
- ASEL
- SSEL
- XSEL
- Pulse Motor
- Servo Motor (24V)
- Servo Motor (230V)
- Linear Motor

RCP3-SA5R RoboCylinder Slider Type 50mm Width Pulse Motor Side-Mounted Motor

■ Configuration: **RCP3** — **SA5R** — **I** — **42P** — — — — —

Series	Type	Encoder	Motor	Lead	Stroke	Compatible Controllers	Cable Length	Option
I: Incremental * The Simple absolute encoder models are labeled as "I".	42P: Pulse motor 42 □ size	12 : 12mm 6 : 6mm 3 : 3mm	50: 50mm 800: 800mm (50mm pitch increments)	P1: PCON RPCON PSEL P3: PMEC PSEP	N : None P : 1m S : 3m M : 5m X □ □ : Custom Length	See Options below * Be sure to specify which side the motor is to be mounted (ML/MR).		

* See page Pre-35 for explanation of each code that make up the configuration name.

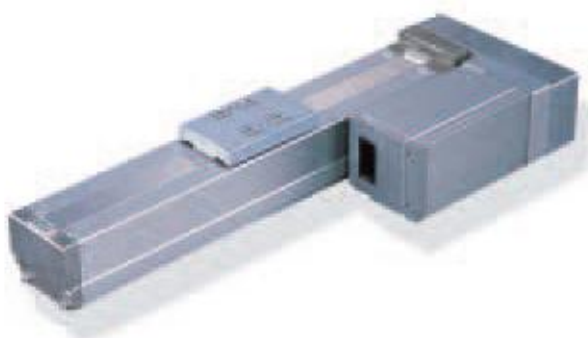

Technical References A-5

- POINT** Notes on Selection
- (1) Since the RCP3 series use a pulse motor, the load capacity decreases at high speeds. Check in the Speed vs. Load Capacity graph to see if your desired speed and load capacity are supported.
 - (2) The load capacity is based on operation at an acceleration of 0.3G (0.2G for the 3mm-lead model). These values are the upper limits for the acceleration.

■ Speed vs. Load Capacity
Due to the characteristics of the pulse motor, the RCP3 series' load capacity decreases at high speeds. In the table below, check if your desired speed and load capacity are supported.

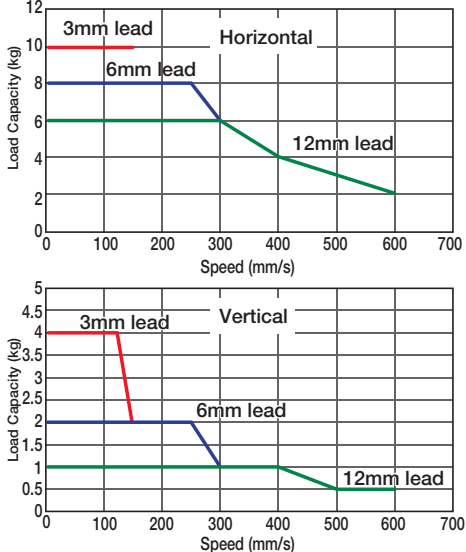

Actuator Specifications						Stroke and Maximum Speed								
■ Lead and Load Capacity						■ Stroke and Maximum Speed								
Model	Lead (mm)	Max. Load Capacity		Maximum Push Force (N)	Stroke (mm)	Stroke Lead	50 ~ 800 (50mm increments)							
		Horizontal (kg)	Vertical (kg)				50	600	650	700	750	800		
RCP3-SA5R-I-42P-12-①-②-③-④	12	~ 6	~ 1	47	50~800 (50mm increments)	12	600	570	490	425	370	330		
RCP3-SA5R-I-42P-6-①-②-③-④	6	~ 8	~ 2	95		6	300	285	245	210	185	165		
RCP3-SA5R-I-42P-3-①-②-③-④	3	10	~ 4	189		3	150	140	120	105	90	80		

Legend ① Stroke ② Compatible controller ③ Cable length ④ Options (Unit: mm/s)

Type	Cable Symbol	
Standard (Robot Cables)	P (1m)	
	S (3m)	
	M (5m)	
Special Lengths	X06 (6m) ~ X10 (10m)	
	X11 (11m) ~ X15 (15m)	
	X16 (16m) ~ X20 (20m)	

* The standard cable is the motor-encoder integrated robot cable.
* See page A-39 for cables for maintenance.

Name	Option Code	See Page
Brake-Equipped	B	→ A-25
Cable Exit Direction (Top)	CJT	→ A-25
Cable Exit Direction (Outside)	CJO	→ A-25
Cable Exit Direction (Bottom)	CJB	→ A-25
Left-Mounted Motor (Standard)	ML	→ A-33
Right-Mounted Motor	MR	→ A-33
No Cover	NCO	→ A-33
Reversed-home	NM	→ A-33

Item	Description
Drive System	Ball screw Ø10mm C10 grade
Positioning Repeatability	±0.02mm
Lost Motion	0.1mm or less
Base	Material: Aluminum (special alumite treated)
Allowable Static Load Moment	Ma: 10.2N·m Mb: 14.6N·m Mc: 8.53N·m
Allowable Dynamic Load Moment	Ma: 3.92N·m Mb: 5.58N·m Mc: 8.53N·m
Overhang Load Length	130mm or less
Ambient Operating Temp./Humidity	0~40°C, 85% RH or less (non-condensing)

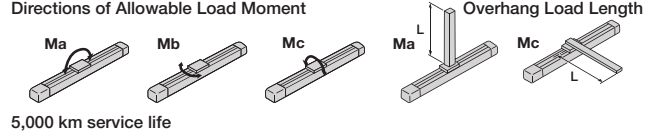

Dimensions

CAD drawings can be downloaded from IAI website. www.robocylinder.de



For Special Orders A-9

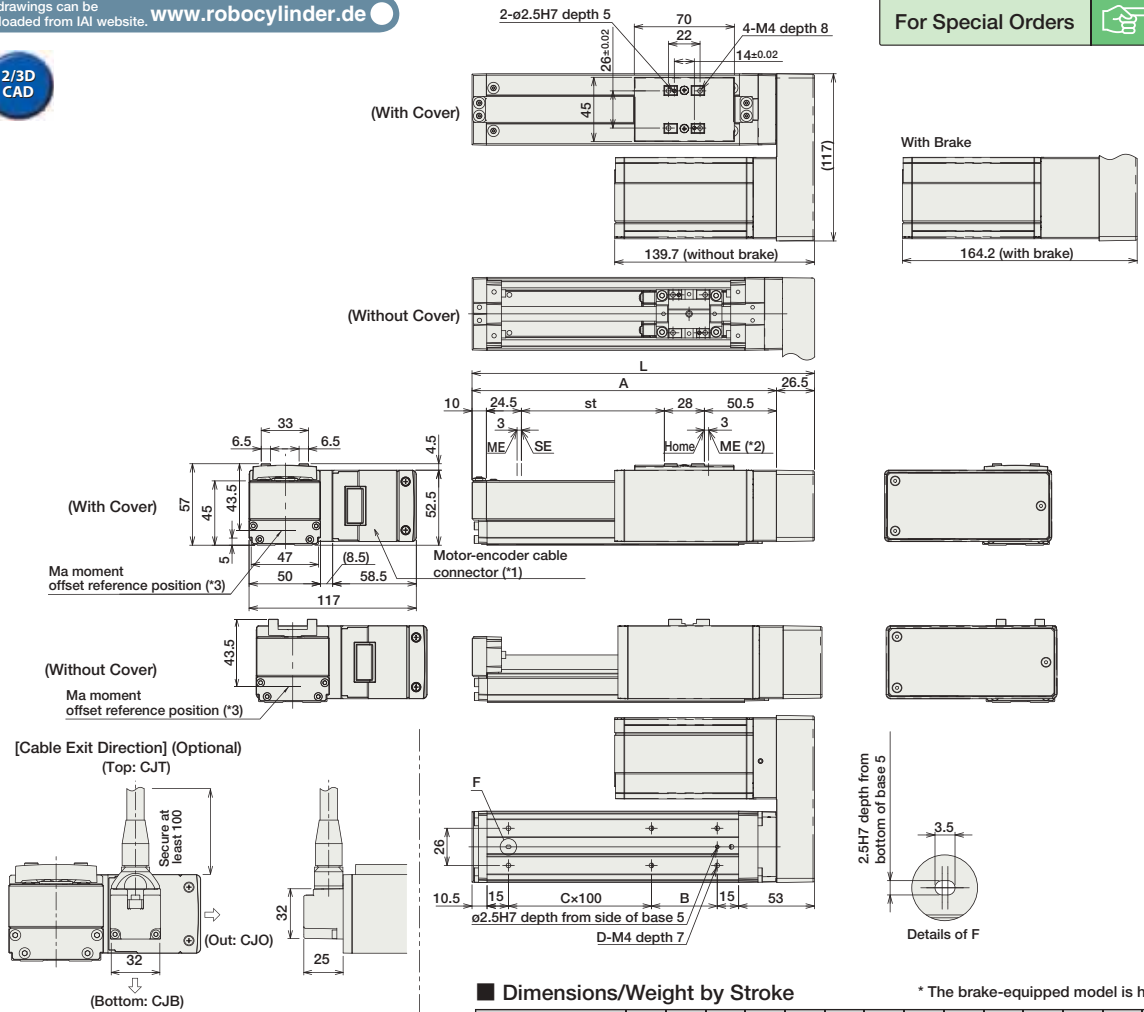

(*)1 The motor-encoder cable provided is an integrated cable. (See page A-39.)
 (*)2 After homing, the slider moves to the ME; therefore, please watch for any interference with surrounding objects.
 ME : Mechanical end
 SE : Stroke end
 (*)3 Reference position for calculating the moment Ma

■ Dimensions/Weight by Stroke

* The brake-equipped model is heavier by 0.4kg.

Stroke	50	100	150	200	250	300	350	400	450	500	550	600	650	700	750	800	
L	189.5	239.5	289.5	339.5	389.5	439.5	489.5	539.5	589.5	639.5	689.5	739.5	789.5	839.5	889.5	939.5	
A	163	213	263	313	363	413	463	513	563	613	663	713	763	813	863	913	
B	96	46	96	46	96	46	96	46	96	46	96	46	96	46	96	46	
C	0	1	1	2	2	3	3	4	4	5	5	6	6	7	7	8	
D	4	6	6	8	8	10	10	12	12	14	14	16	16	18	18	20	
Weight (kg)	With Cover	1.7	1.8	1.9	2.1	2.2	2.3	2.5	2.6	2.8	2.9	3.0	3.2	3.3	3.4	3.6	3.7
	No Cover	1.6	1.7	1.8	1.9	2.0	2.1	2.3	2.4	2.5	2.6	2.7	2.8	2.9	3.1	3.2	3.3

Compatible Controllers

The RCP3 series actuators can operate with the controllers below. Select the controller according to your usage.

Name	External View	Model	Description	Max. Positioning Points	Input Voltage	Power Supply Capacity	See Page
Solenoid Valve Type		PMEC-C-42PI-NP-2-2	Easy-to-use controller, even for beginners	3 points	AC115V AC230V	See P481	→ P477
		PSEP-C-42PI-NP-2-0	Operable with same signal as solenoid valve. Supports both single and double solenoid types. No homing necessary with simple absolute type.				→ P487
Splash-Proof Solenoid Valve Type		PSEP-CW-42PI-NP-2-0					
Positioner Type		PCON-C-42PI-NP-2-0	Positioning is possible for up to 512 points	512 points			
Safety-Compliant Positioner Type		PCON-CG-42PI-NP-2-0					
Pulse Train Input Type (Differential Line Driver)		PCON-PL-42PI-NP-2-0	Pulse train input type with differential line driver support	(-)	DC24V	2A max.	→ P525
Pulse Train Input Type (Open Collector)		PCON-PO-42PI-NP-2-0	Pulse train input type with open collector support				
Serial Communication Type		PCON-SE-42PI-N-0-0	Dedicated to serial communication	64 points			
Field Network Type		RPCON-42P	Dedicated to field network	768 points			→ P503
Program Control Type		PSEL-C-1-42PI-NP-2-0	Programmed operation is possible. Can operate up to 2 axes	1500 points			→ P557

* This is for the single-axis PSEL.

- Slider Type
- Mini
- Standard
- Controllers Integrated
- Rod Type
- Mini
- Standard
- Controllers Integrated
- Table/Arm /Flat Type
- Mini
- Standard
- Gripper/ Rotary Type
- Linear Motor Type
- Cleanroom Type
- Splash-Proof
- Controllers
- PMEC /AMEC
- PSEP /ASEP
- ROBO NET
- ERC2
- PCON
- ACON
- SCON
- PSEL
- ASEL
- SSEL
- XSEL
- Pulse Motor
- Servo Motor (24V)
- Servo Motor (230V)
- Linear Motor

- Slider Type
- Mini
- Standard
- Controllers Integrated
- Rod Type
- Mini
- Standard
- Controllers Integrated
- Table/Arm /Flat Type
- Mini
- Standard
- Gripper/ Rotary Type
- Linear Motor Type
- Cleanroom Type
- Splash-Proof
- Controllers
- PMEC /AMEC
- PSEP /ASEP
- ROBO NET
- ERC2
- PCON
- ACON
- SCON
- PSEL
- ASEL
- SSEL
- XSEL
- Pulse Motor
- Servo Motor (24V)
- Servo Motor (230V)
- Linear Motor

RCP3-SA6R

RoboCylinder Slider Type 60mm Width Pulse Motor Side-Mounted Motor

■ Configuration: **RCP3** — **SA6R** — **I** — **42P** — — — — —

Series	Type	Encoder	Motor	Lead	Stroke	Compatible Controllers	Cable Length	Option
I: Incremental * The Simple absolute encoder models are labeled as "I".	42P: Pulse motor 42 □ size	12 : 12mm 6 : 6mm 3 : 3mm	50: 50mm 800: 800mm (50mm pitch increments)	P1: PCON RPCON PSEL P3: PMECP PSEP	N : None P : 1m S : 3m M : 5m X □ □ : Custom Length	See Options below * Be sure to specify which side the motor is to be mounted (ML/MR).		

* See page Pre-35 for explanation of each code that make up the configuration name.

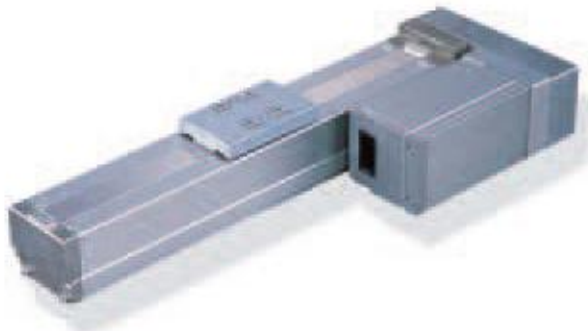

Technical References A-5

- POINT** Notes on Selection
- When the stroke increases, the maximum speed will drop to prevent the ball screw from reaching the critical rotational speed. Use the actuator specification table below to check the maximum speed at the stroke you desire.
 - Since the RCP3 series use the pulse motor, the load capacity decreases at high speeds. Check in the Speed vs. Load Capacity graph to see if your desired speed and load capacity are supported.
 - The load capacity is based on operation at an acceleration of 0.3G (0.2G for the 3mm-lead model, or when used vertically). These values are the upper limits for the acceleration.

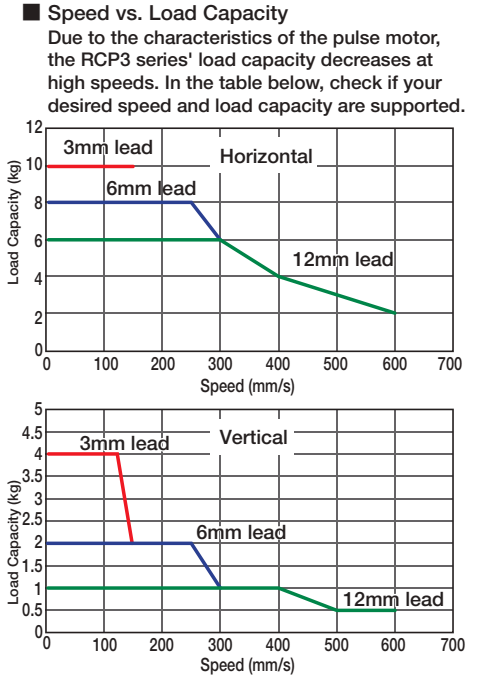

Actuator Specifications

■ Lead and Load Capacity

Model	Lead (mm)	Max. Load Capacity		Maximum Push Force (N)	Stroke (mm)
		Horizontal (kg)	Vertical (kg)		
RCP3-SA6R-I-42P-12-①-②-③-④	12	~ 6	~ 1	47	50~800 (50mm increments)
RCP3-SA6R-I-42P-6-①-②-③-④	6	~ 8	~ 2	95	
RCP3-SA6R-I-42P-3-①-②-③-④	3	10	~ 4	189	

Legend ① Stroke ② Compatible controller ③ Cable length ④ Options

■ Stroke and Maximum Speed

Stroke Lead	50 ~ 550	600	650	700	750	800
	(50mm increments)	(mm)	(mm)	(mm)	(mm)	(mm)
12	600	570	490	425	370	330
6	300	285	245	210	185	165
3	150	140	120	105	90	80

(Unit: mm/s)

Cable List

Type	Cable Symbol
Standard (Robot Cables)	P (1m)
	S (3m)
	M (5m)
Special Lengths	X06 (6m) ~ X10 (10m)
	X11 (11m) ~ X15 (15m)
	X16 (16m) ~ X20 (20m)

* The standard cable is the motor-encoder integrated robot cable.
* See page A-39 for cables for maintenance.

Option List

Name	Option Code	See Page
Brake-Equipped	B	→ A-25
Cable Exit Direction (Top)	CJT	→ A-25
Cable Exit Direction (Outside)	CJO	→ A-25
Cable Exit Direction (Bottom)	CJB	→ A-25
Left-Mounted Motor (Standard)	ML	→ A-33
Right-Mounted Motor	MR	→ A-33
No Cover	NCO	→ A-33
Reversed-home	NM	→ A-33

Actuator Specifications

Item	Description
Drive System	Ball screw Ø10mm C10 grade
Positioning Repeatability	±0.02mm
Lost Motion	0.1mm or less
Base	Material: Aluminum (special alumite treated)
Allowable Static Load Moment	Ma: 17.6N·m Mb: 25.2N·m Mc: 44.5N·m
Allowable Dynamic Load Moment	Ma: 4.31N·m Mb: 6.17N·m Mc: 10.98N·m
Overhang Load Length	150mm or less
Ambient Operating Temp./Humidity	0~40°C, 85% RH or less (non-condensing)

Directions of Allowable Load Moment

Overhang Load Length

5,000 km service life

Dimensions

CAD drawings can be downloaded from IAI website. www.robocylinder.de



- (*1) The motor-encoder cable provided is an integrated cable. (See page A-39)
- (*2) After homing, the slider moves to the ME; therefore, please watch for any interference with surrounding objects.
ME : Mechanical end
SE : Stroke end
- (*3) Reference position for calculating the moment Ma

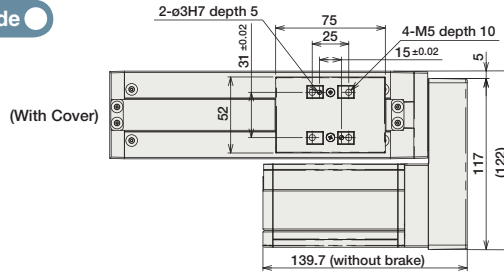

For Special Orders A-9

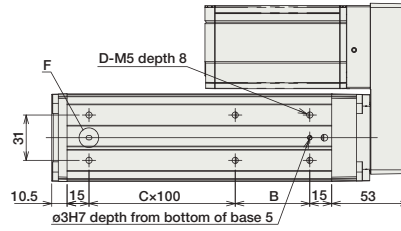
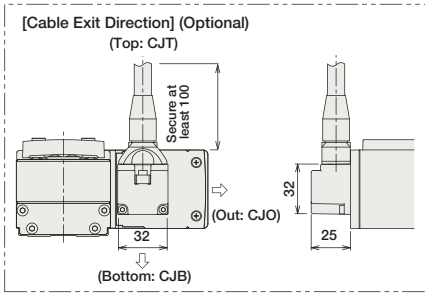
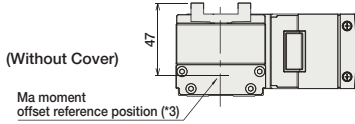
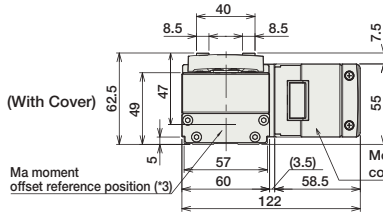

■ Dimensions/Weight by Stroke

* The brake-equipped model is heavier by 0.4kg.

Stroke	50	100	150	200	250	300	350	400	450	500	550	600	650	700	750	800	
L	194.5	244.5	294.5	344.5	394.5	444.5	494.5	544.5	594.5	644.5	694.5	744.5	794.5	844.5	894.5	944.5	
A	168	218	268	318	368	418	468	518	568	618	668	718	768	818	868	918	
B	101	51	101	51	101	51	101	51	101	51	101	51	101	51	101	51	
C	0	1	1	2	2	3	3	4	4	5	5	6	6	7	7	8	
D	4	6	6	8	8	10	10	12	12	14	14	16	16	18	18	20	
Weight (kg)	With Cover	1.9	2.1	2.3	2.4	2.6	2.8	3.0	3.1	3.3	3.5	3.6	3.8	4.0	4.2	4.3	4.5
	No Cover	1.8	2.0	2.1	2.3	2.4	2.6	2.7	2.9	3.0	3.1	3.3	3.4	3.6	3.7	3.9	4.0

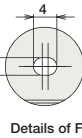

Compatible Controllers

The RCP3 series actuators can operate with the controllers below. Select the controller according to your usage.

Name	External View	Model	Description	Max. Positioning Points	Input Voltage	Power Supply Capacity	See Page
Solenoid Valve Type		PMEC-C-42PI-NP-2-2	Easy-to-use controller, even for beginners	3 points	AC115V AC230V	See P481	→ P477
		PSEP-C-42PI-NP-2-0	Operable with same signal as solenoid valve. Supports both single and double solenoid types. No homing necessary with simple absolute type.				
Splash-Proof Solenoid Valve Type		PSEP-CW-42PI-NP-2-0					
Positioner Type		PCON-C-42PI-NP-2-0	Positioning is possible for up to 512 points	512 points			
Safety-Compliant Positioner Type		PCON-CG-42PI-NP-2-0					
Pulse Train Input Type (Differential Line Driver)		PCON-PL-42PI-NP-2-0	Pulse train input type with differential line driver support	(-)	DC24V	2A max.	→ P525
Pulse Train Input Type (Open Collector)		PCON-PO-42PI-NP-2-0	Pulse train input type with open collector support				
Serial Communication Type		PCON-SE-42PI-N-0-0	Dedicated to serial communication	64 points			
Field Network Type		RPCON-42P	Dedicated to field network	768 points			→ P503
Program Control Type		PSEL-C-1-42PI-NP-2-0	Programmed operation is possible. Can operate up to 2 axes	1500 points			→ P557

* This is for the single-axis PSEL.

- Slider Type
- Mini
- Standard
- Controllers Integrated
- Rod Type
- Mini
- Standard
- Controllers Integrated
- Table/Arm /Flat Type
- Mini
- Standard
- Gripper/ Rotary Type
- Linear Motor Type
- Cleanroom Type
- Splash-Proof
- Controllers
- PMEC /AMEC
- PSEP /ASEP
- ROBO NET
- ERC2
- PCON
- ACON
- SCON
- PSEL
- ASEL
- SSEL
- XSEL
- Pulse Motor
- Servo Motor (24V)
- Servo Motor (230V)
- Linear Motor

RCP2-SA5C RoboCylinder Slider Type 52mm Width Pulse Motor Straight Type Coupled

■ Configuration: **RCP2** - **SA5C** - **I** - **42P** - [] - [] - [] - [] - []

Series — Type — Encoder — Motor — Lead — Stroke — Compatible Controllers — Cable Length — Option

I: Incremental
* The Simple absolute encoder models are labeled as "I".

42P: Pulse motor
42 □ size

20 : 20mm
12 : 12mm
6 : 6mm
3 : 3mm

50: 50mm
)
800:800mm
(50mm pitch increments)

P1:PCON
RPCON
PSEL
P3:PMEC
PSEP

N : None
P : 1m
S : 3m
M : 5m
X □ : Custom Length
R □ : Robot cable

BE : Brake (Cable exiting end)
BL : Brake (Cable exiting left)
BR : Brake (Cable exiting right)
NM : Reversed-home
SR : Slider Roller

* See page Pre-35 for explanation of each code that makes up the configuration name.

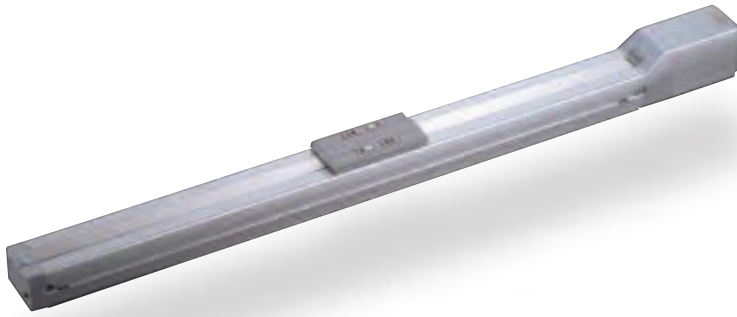

Technical References A-5



- (1) When the stroke increases, the maximum speed will drop to prevent the ball screw from reaching the critical rotational speed. Use the actuator specification table below to check the maximum speed at the stroke you desire.
- (2) Since the RCP2 series use a pulse motor, the load capacity decreases at high speeds. Check in the Speed vs. Load Capacity graph to see if your desired speed and load capacity are supported.
- (3) The load capacity is based on operation at an acceleration of 0.3G (0.2G for the 3mm-lead model, or when used vertically). The maximum acceleration is 0.7G (0.3G when used vertically), however, note that the load capacity decreases at high accelerations. For more information, see the table of load capacity by acceleration, on page A-53.

■ Speed vs. Load Capacity
Due to the characteristics of the pulse motor, the RCP2 series' load capacity decreases at high speeds. In the table below, check if your desired speed and load capacity are supported.

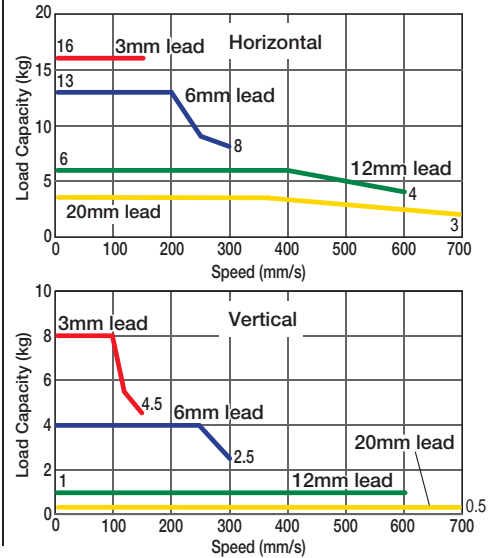

Actuator Specifications

Lead and Load Capacity

Model	Lead (mm)	Max. Load Capacity (Note 1)		Stroke (mm)
		Horizontal (kg)	Vertical (kg)	
RCP2-SA5C-I-42P-20- [1]-[2]-[3]-[4]	20	~ 4	~ 0.5	50-800 (50mm increments)
RCP2-SA5C-I-42P-12- [1]-[2]-[3]-[4]	12	~ 6	~ 1	
RCP2-SA5C-I-42P-6- [1]-[2]-[3]-[4]	6	~ 13	~ 4	
RCP2-SA5C-I-42P-3- [1]-[2]-[3]-[4]	3	~16	~ 8	

Legend [1] Stroke [2] Compatible controller [3] Cable length [4] Options

Stroke and Maximum Speed

Stroke Lead	50 ~ 550 (50mm increments)	600 (mm)	650 (mm)	700 (mm)	750 (mm)	800 (mm)
20	1000	980	850	740	650	580
12	600	540	460	400	360	300
6	300	270	230	200	180	150
3	150	135	115	100	90	75

(Unit: mm/s)

Cable List

Type	Cable Symbol
Standard	P (1m)
	S (3m)
	M (5m)
Special Lengths	X06 (6m) ~ X10 (10m)
	X11 (11m) ~ X15 (15m)
	X16 (16m) ~ X20 (20m)
	R01 (1m) ~ R03 (3m)
Robot Cable	R04 (4m) ~ R05 (5m)
	R06 (6m) ~ R10 (10m)
	R11 (11m) ~ R15 (15m)
	R16 (16m) ~ R20 (20m)

* See page A-39 for cables for maintenance.

Option List

Name	Option Code	See Page
Brake (Cable-exit end)	BE	→ A-25
Brake (Cable exiting left)	BL	→ A-25
Brake (Cable exiting right)	BR	→ A-25
Reversed-home	NM	→ A-33
Slider Roller	SR	→ A-36

Actuator Specifications

Item	Description
Drive System	Ball screw Ø10mm C10 grade
Positioning Repeatability	±0.02mm
Lost Motion	0.1mm or less
Base	Material: Aluminum (special alumite treated)
Allowable Static Moment	Ma: 18.6 N·m Mb: 26.6 N·m Mc: 47.5 N·m
Allowable Dynamic Moment (*)	Ma: 4.9 N·m Mb: 6.8 N·m Mc: 11.7 N·m
Overhang Load Length	Ma direction: 150mm or less; Mb-Mc direction: 150mm or less
Ambient Operating Temp./Humidity	0~40°C, 85% RH or less (Non-condensing)

(*) Based on 5,000km travel life.

Directions of Allowable Load Moments

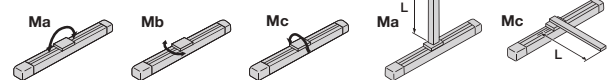

Dimensions

CAD drawings can be downloaded from IAI website. www.robocylinder.de



*For the Reversed-home model, the dimensions (distance to home) on the motor-side and that on the opposite side are flipped.

For Special Orders A-9

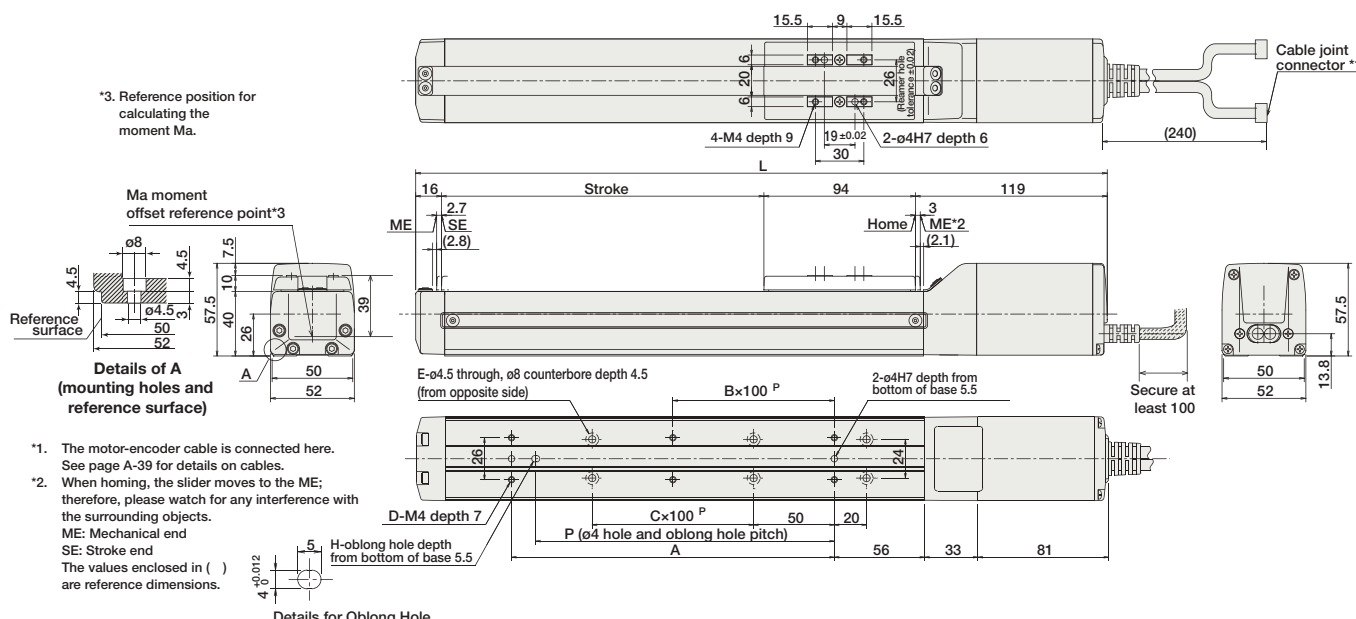

- *1. The motor-encoder cable is connected here. See page A-39 for details on cables.
- *2. When homing, the slider moves to the ME; therefore, please watch for any interference with the surrounding objects.
 ME: Mechanical end
 SE: Stroke end
 The values enclosed in () are reference dimensions.

■ Dimensions/Weight by Stroke

Stroke	50	100	150	200	250	300	350	400	450	500	550	600	650	700	750	800
L	279	329	379	429	479	529	579	629	679	729	779	829	879	929	979	1029
A	73	100	100	200	200	300	300	400	400	500	500	600	600	700	700	800
B	0	0	0	1	1	2	2	3	3	4	4	5	5	6	6	7
C	0	0	1	1	2	2	3	3	4	4	5	5	6	6	7	7
D	4	4	4	6	6	8	8	10	10	12	12	14	14	16	16	18
E	4	4	6	6	8	8	10	10	12	12	14	14	16	16	18	18
H	0	1	1	1	1	1	1	1	1	1	1	1	1	1	1	1
P	0	85	85	185	185	285	285	385	385	485	485	585	585	685	685	785
Weight (kg)	1.5	1.6	1.7	1.8	1.9	2.1	2.2	2.3	2.4	2.5	2.6	2.8	2.9	3.0	3.1	3.2

* Adding a brake increases the actuator's overall length by 40mm (53.3mm with the cable coming out its end), and its weight by 0.4kg.

Compatible Controllers

The RCP2 series actuators can operate with the controllers below. Select the controller according to your usage.

Name	External View	Model	Description	Max. Positioning Points	Input Voltage	Power Supply Capacity	See Page
Solenoid Valve Type		PMEC-C-42PI-NP-2-2	Easy-to-use controller, even for beginners	3 points	AC115V AC230V	See P481	→ P477
		PSEP-C-42PI-NP-2-0-H	Operable with same signal as solenoid valve. Supports both single and double solenoid types. No homing necessary with simple absolute type.				→ P487
Splash-Proof Solenoid Valve Type		PSEP-CW-42PI-NP-2-0-H					
Positioner Type		PCON-C-42PI-NP-2-0-H	Positioning is possible for up to 512 points	512 points			
Safety-Compliant Positioner Type		PCON-CG-42PI-NP-2-0-H					
Pulse Train Input Type (Differential Line Driver)		PCON-PL-42PI-NP-2-0-H	Pulse train input type with differential line driver support	(-)	DC24V	2A max.	→ P525
Pulse Train Input Type (Open Collector)		PCON-PO-42PI-NP-2-0-H	Pulse train input type with open collector support				
Serial Communication Type		PCON-SE-42PI-N-0-0-H	Dedicated to serial communication	64 points			
Field Network Type		RPCON-42P-H	Dedicated to field network	768 points			→ P503
Program Control Type		PSEL-C-1-42PI-NP-2-0-H	Programmed operation is possible. Can operate up to 2 axes	1500 points			→ P557

* This is for the single-axis PSEL.

- Slider Type
- Mini
- Standard
- Controllers Integrated
- Rod Type
- Mini
- Standard
- Controllers Integrated
- Table/Arm /Flat Type
- Mini
- Standard
- Gripper/ Rotary Type
- Linear Motor Type
- Cleanroom Type
- Splash-Proof
- Controllers
- PMEC /AMEC
- PSEP /ASEP
- ROBO NET
- ERC2
- PCON
- ACON
- SCON
- PSEL
- ASEL
- SSEL
- XSEL
- Pulse Motor
- Servo Motor (24V)
- Servo Motor (230V)
- Linear Motor

- Slider Type
- Mini
- Standard
- Controllers Integrated
- Rod Type
- Mini
- Standard
- Controllers Integrated
- Table/Arm /Flat Type
- Mini
- Standard
- Gripper/ Rotary Type
- Linear Motor Type
- Cleanroom Type
- Splash-Proof
- Controllers
- PMEC /AMEC
- PSEP /ASEP
- ROBO NET
- ERC2
- PCON
- ACON
- SCON
- PSEL
- ASEL
- SSEL
- XSEL
- Pulse Motor
- Servo Motor (24V)
- Servo Motor (230V)
- Linear Motor

RCP2-SA6C RoboCylinder Slider Type 58mm Width Pulse Motor Straight Type Coupled

■ Configuration: **RCP2** - **SA6C** - **I** - **42P** - [] - [] - [] - [] - []

Series — Type — Encoder — Motor — Lead — Stroke — Compatible Controllers — Cable Length — Option

I: Incremental 42P: Pulse motor 20 : 20mm 50: 50mm P1:PCON N : None BE : Brake (Cable exiting end)
 * The Simple absolute encoder models are labeled as "I". 42 □ size 12 : 12mm 6 : 6mm 800:800mm (50mm pitch increments) PCON R : None BL : Brake (Cable exiting left)
 PSEL S : 3m BR : Brake (Cable exiting right)
 P3:PMEC M : 5m NM : Reversed-home
 PSEP X □ □ : Custom Length SR : Slider Roller
 R □ □ : Robot cable

* See page Pre-35 for explanation of each code that makes up the configuration name.

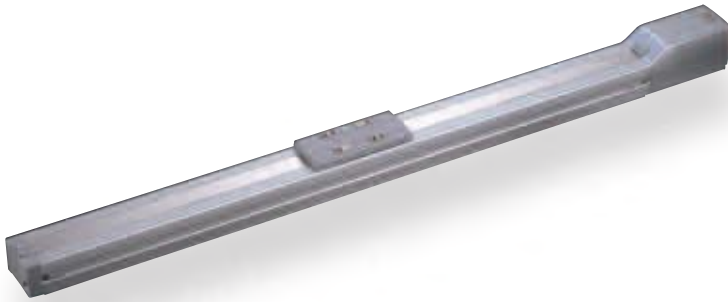

Technical References A-5

POINT Notes on Selection

- When the stroke increases, the maximum speed will drop to prevent the ball screw from reaching the critical rotational speed. Use the actuator specification table below to check the maximum speed at the stroke you desire.
- Since the RCP2 series use a pulse motor, the load capacity decreases at high speeds. Check in the Speed vs. Load Capacity graph to see if your desired speed and load capacity are supported.
- The load capacity is based on operation at an acceleration of 0.3G (0.2G for the 3mm-lead model, or when used vertically). The maximum acceleration is 0.7G (0.3G when used vertically), however, note that the load capacity decreases at high accelerations. For more information, see the table of load capacity by acceleration, on page A-53.

■ Speed vs. Load Capacity
 Due to the characteristics of the pulse motor, the RCP2 series' load capacity decreases at high speeds. In the table below, check if your desired speed and load capacity are supported.

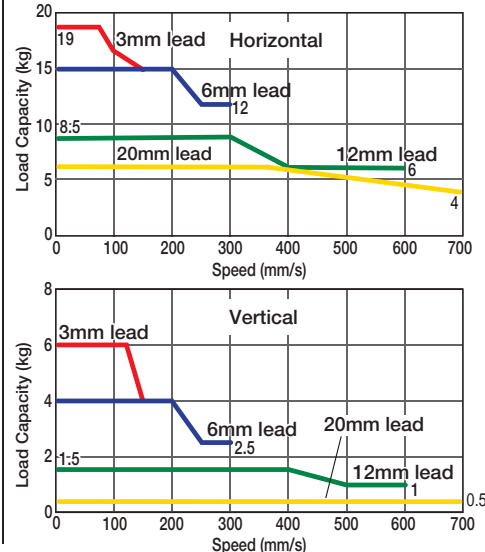

Actuator Specifications

Lead and Load Capacity

Model	Lead (mm)	Max. LoadCapacity (Note 1)		Stroke (mm)
		Horizontal (kg)	Vertical (kg)	
RCP2-SA6C-I-42P-20- [1]-[2]-[3]-[4]	20	~ 6	~ 0.5	50-800 (50mm increments)
RCP2-SA6C-I-42P-12- [1]-[2]-[3]-[4]	12	~ 8.5	~ 1.5	
RCP2-SA6C-I-42P-6- [1]-[2]-[3]-[4]	6	~ 15	~ 4	
RCP2-SA6C-I-42P-3- [1]-[2]-[3]-[4]	3	~ 19	~ 6	

Legend [1] Stroke [2] Compatible controller [3] Cable length [4] Options

Stroke and Maximum Speed

Stroke Lead (mm)	50 ~ 550 (50mm increments)	600 (mm)	650 (mm)	700 (mm)	750 (mm)	800 (mm)
	20	1000	980	850	740	650
12	600	540	460	400	360	300
6	300	270	230	200	180	150
3	150	135	115	100	90	75

(Unit: mm/s)

Cable List

Type	Cable Symbol
Standard	P (1m)
	S (3m)
	M (5m)
Special Lengths	X06 (6m) ~ X10 (10m)
	X11 (11m) ~ X15 (15m)
	X16 (16m) ~ X20 (20m)
	R01 (1m) ~ R03 (3m)
Robot Cable	R04 (4m) ~ R05 (5m)
	R06 (6m) ~ R10 (10m)
	R11 (11m) ~ R15 (15m)
	R16 (16m) ~ R20 (20m)

* See page A-39 for cables for maintenance.

Option List

Name	Option Code	See Page
Brake (Cable-exit end)	BE	→ A-25
Brake (Cable exiting left)	BL	→ A-25
Brake (Cable exiting right)	BR	→ A-25
Reversed-home	NM	→ A-33
Slider Roller	SR	→ A-36

Actuator Specifications

Item	Description
Drive System	Ball screw Ø10mm C10 grade
Positioning Repeatability	±0.02mm
Lost Motion	0.1mm or less
Base	Material: Aluminum (special alumite treated)
Allowable Static Moment	Ma: 38.3 N·m Mb: 54.7 N·m Mc: 81.0 N·m
Allowable Dynamic Moment (*)	Ma: 8.9 N·m Mb: 12.7 N·m Mc: 18.6 N·m
Overhang Load Length	Ma direction: 220mm or less; Mb-Mc direction: 220mm or less
Ambient Operating Temp./Humidity	0~40°C, 85% RH or less (Non-condensing)

(*) Based on 5,000km travel life.

Directions of Allowable Load Moments

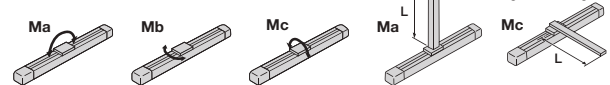

Dimensions

CAD drawings can be downloaded from IAI website. www.robocylinder.de

For Special Orders



*For the Reversed-home model, the dimensions (distance to home) on the motor-side and that on the opposite side are flipped.

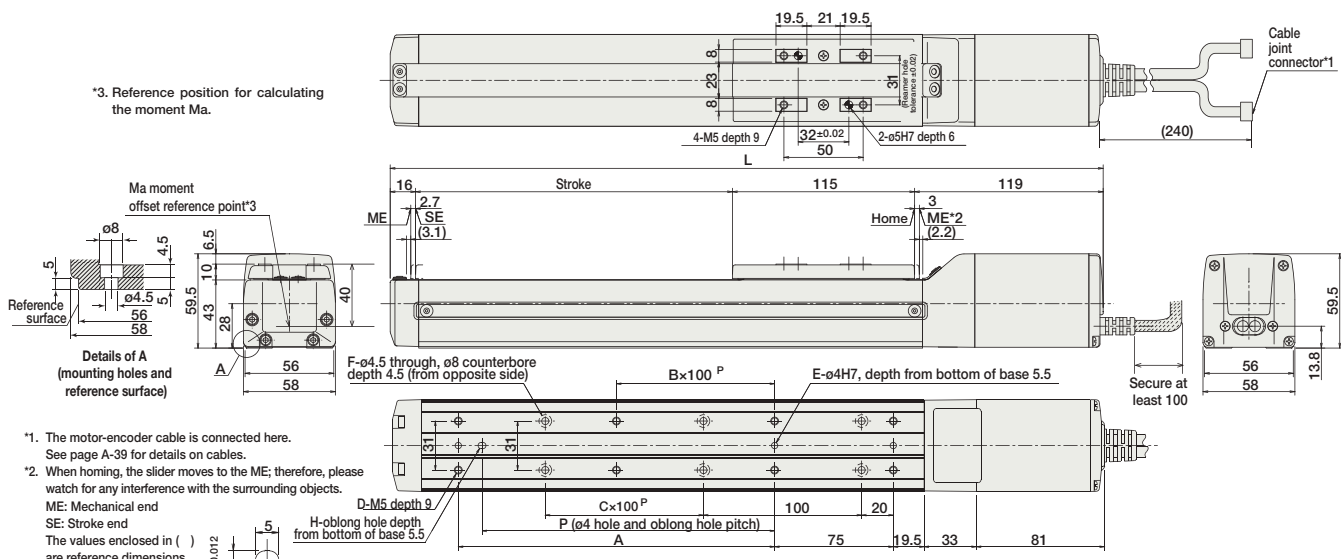

*3. Reference position for calculating the moment Ma.

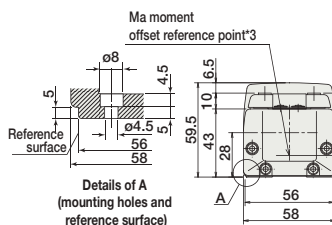

- *1. The motor-encoder cable is connected here. See page A-39 for details on cables.
- *2. When homing, the slider moves to the ME; therefore, please watch for any interference with the surrounding objects.
ME: Mechanical end
SE: Stroke end
The values enclosed in () are reference dimensions.

Dimensions of the brake section

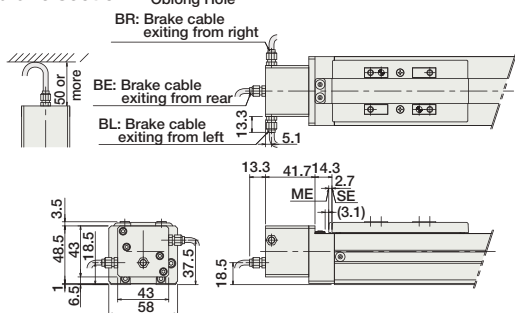

Dimensions/Weight by Stroke

Stroke	50	100	150	200	250	300	350	400	450	500	550	600	650	700	750	800
L	300	350	400	450	500	550	600	650	700	750	800	850	900	950	1000	1050
A	0	100	100	200	200	300	300	400	400	500	500	600	600	700	700	800
B	0	0	0	1	1	2	2	3	3	4	4	5	5	6	6	7
C	0	0	1	1	2	2	3	3	4	4	5	5	6	6	7	7
D	4	6	6	8	8	10	10	12	12	14	14	16	16	18	18	20
E	2	3	3	3	3	3	3	3	3	3	3	3	3	3	3	3
F	4	4	6	6	8	8	10	10	12	12	14	14	16	16	18	18
H	0	1	1	1	1	1	1	1	1	1	1	1	1	1	1	1
P	0	85	85	185	185	285	285	385	385	485	485	585	585	685	685	785
Weight (kg)	1.8	2.0	2.1	2.2	2.4	2.5	2.7	2.8	2.9	3.1	3.2	3.4	3.5	3.6	3.8	3.9

* Adding a brake increases the actuator's overall length by 40mm (53.3mm with the cable coming out its end), and its weight by 0.4kg.

Compatible Controllers

The RCP2 series actuators can operate with the controllers below. Select the controller according to your usage.

Name	External View	Model	Description	Max. Positioning Points	Input Voltage	Power Supply Capacity	See Page
Solenoid Valve Type		PMEC-C-42PI-NP-2-2	Easy-to-use controller, even for beginners	3 points	AC115V AC230V	See P481	→ P477
		PSEP-C-42PI-NP-2-0-H	Operable with same signal as solenoid valve. Supports both single and double solenoid types. No homing necessary with simple absolute type.				
Splash-Proof Solenoid Valve Type		PSEP-CW-42PI-NP-2-0-H					
Positioner Type		PCON-C-42PI-NP-2-0-H	Positioning is possible for up to 512 points	512 points			
Safety-Compliant Positioner Type		PCON-CG-42PI-NP-2-0-H					
Pulse Train Input Type (Differential Line Driver)		PCON-PL-42PI-NP-2-0-H	Pulse train input type with differential line driver support	(-)	DC24V	2A max.	→ P625
Pulse Train Input Type (Open Collector)		PCON-PO-42PI-NP-2-0-H	Pulse train input type with open collector support				
Serial Communication Type		PCON-SE-42PI-N-0-0-H	Dedicated to serial communication	64 points			
Field Network Type		RPCON-42P-H	Dedicated to field network	768 points			→ P503
Program Control Type		PSEL-C-1-42PI-NP-2-0-H	Programmed operation is possible Can operate up to 2 axes	1500 points			→ P557

* This is for the single-axis PSEL.

- Slider Type
- Mini
- Standard
- Controllers Integrated
- Rod Type
- Mini
- Standard
- Controllers Integrated
- Table/Arm /Flat Type
- Mini
- Standard
- Gripper/ Rotary Type
- Linear Motor Type
- Cleanroom Type
- Splash-Proof
- Controllers
- PMEC /AMEC
- PSEP /ASEP
- ROBO NET
- ERC2
- PCON
- ACON
- SCON
- PSEL
- ASEL
- SSEL
- XSEL
- Pulse Motor
- Servo Motor (24V)
- Servo Motor (230V)
- Linear Motor

RCP2-SA7C RoboCylinder Slider Type 73mm Width Pulse Motor Straight Type Coupled

■ Configuration: **RCP2 - SA7C - I - 56P** - [] - [] - [] - [] - []

Series - Type - Encoder - Motor - Lead - Stroke - Compatible Controllers - Cable Length - Option

I: Incremental * The Simple absolute encoder models are labeled as "I".
 56P: Pulse motor 56 □ size
 16: 16mm
 8: 8mm
 4: 4mm
 50: 50mm
 800: 800mm (50mm pitch increments)
 P1: PCON
 RP CON
 PSEL
 P3: PME C
 PSEP
 N: None
 P: 1m
 S: 3m
 M: 5m
 X □ □: Custom Length¹⁾
 R □ □: Robot cable
 BE: Brake (Cable exiting end)
 BL: Brake (Cable exiting left)
 BR: Brake (Cable exiting right)
 NM: Reversed-home
 SR: Slider Roller

* See page Pre-35 for explanation of each code that makes up the configuration name.

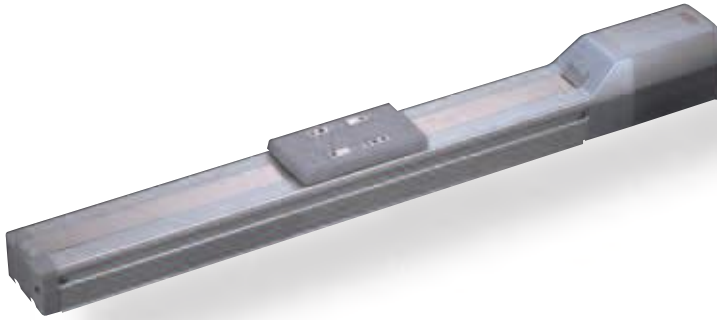

Technical References A-5

- POINT** Notes on Selection
- When the stroke increases, the maximum speed will drop to prevent the ball screw from reaching the critical rotational speed. Use the actuator specification table below to check the maximum speed at the stroke you desire.
 - Since the RCP2 series use a pulse motor, the load capacity decreases at high speeds. Check in the Speed vs. Load Capacity graph to see if your desired speed and load capacity are supported.
 - The load capacity is based on operation at an acceleration of 0.3G (0.2G for the 4mm-lead model, or when used vertically). These values are the upper limits for the acceleration.

■ Speed vs. Load Capacity
 Due to the characteristics of the pulse motor, the RCP2 series' load capacity decreases at high speeds. In the table below, check if your desired speed and load capacity are supported.

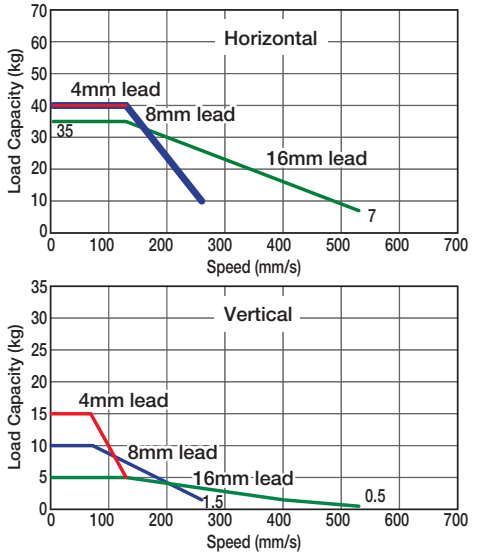

Actuator Specifications

■ Lead and Load Capacity (Note 1) Please note that the maximum load capacity decreases as the speed increases.

Model	Lead (mm)	Max. Load Capacity (Note 1)		Stroke (mm)
		Horizontal (kg)	Vertical (kg)	
RCP2-SA7C-I-56P-16-①-②-③-④	16	~ 35	~ 5	50 ~ 800 (50mm increments)
RCP2-SA7C-I-56P-8-①-②-③-④	8	~ 40	~ 10	
RCP2-SA7C-I-56P-4-①-②-③-④	4	40	~ 15	

Legend ① Stroke ② Compatible controller ③ Cable length ④ Options

■ Stroke and Maximum Speed

Stroke / Lead	50 ~ 700 (50mm increments)	~ 800 (mm)
	16	533
8	266	240
4	133	120

(Unit: mm/s)

Cable List

Type	Cable Symbol
Standard	P (1m)
	S (3m)
	M (5m)
Special Lengths	X06 (6m) ~ X10 (10m)
	X11 (11m) ~ X15 (15m)
	X16 (16m) ~ X20 (20m)
Robot Cable	R01 (1m) ~ R03 (3m)
	R04 (4m) ~ R05 (5m)
	R06 (6m) ~ R10 (10m)
	R11 (11m) ~ R15 (15m)
	R16 (16m) ~ R20 (20m)

* See page A-39 for cables for maintenance.

Actuator Specifications

Item	Description
Drive System	Ball screw ø12mm C10 grade
Positioning Repeatability	±0.02mm
Lost Motion	0.1mm or less
Base	Material: Aluminum (special alumite treated)
Allowable Static Moment	Ma: 50.4 N·m Mb: 71.9 N·m Mc: 138.0 N·m
Allowable Dynamic Moment (*)	Ma: 13.9 N·m Mb: 19.9 N·m Mc: 38.3 N·m
Overhang Load Length	Ma direction: 230mm or less; Mb-Mc direction: 230mm or less
Ambient Operating Temp./Humidity	0~40°C, 85% RH or less (Non-condensing)

(*) Based on 5,000km travel life.
 Directions of Allowable Load Moments

Option List

Name	Option Code	See Page
Brake (Cable-exit end)	BE	→ A-25
Brake (Cable exiting left)	BL	→ A-25
Brake (Cable exiting right)	BR	→ A-25
Reversed-home	NM	→ A-33
Slider Roller	SR	→ A-36

- Slider Type
- Mini
- Standard
- Controllers Integrated
- Rod Type
- Mini
- Standard
- Controllers Integrated
- Table/Arm /Flat Type
- Mini
- Standard
- Gripper/ Rotary Type
- Linear Motor Type
- Cleanroom Type
- Splash-Proof
- Controllers
- PMEC /AMEC
- PSEP /ASEP
- ROBO NET
- ERC2
- PCON
- ACON
- SCON
- PSEL
- ASEL
- SSEL
- XSEL
- Pulse Motor
- Servo Motor (24V)
- Servo Motor (230V)
- Linear Motor

RCP2-SS7C RoboCylinder Slider Type 60mm Width Pulse Motor Straight Type Coupled

■ Configuration: **RCP2** - **SS7C** - **I** - **42P** - [] - [] - [] - [] - []

Series - Type - Encoder - Motor - Lead - Stroke - Compatible Controllers - Cable Length - Option

I: Incremental * The Simple absolute encoder models are labeled as "I".
 42P: Pulse motor 42 □ size
 12: 12mm 6: 6mm 3: 3mm
 50: 50mm 600: 600mm (50mm pitch increments)
 P1: PCON RPCON PSEL P3: PMECPSEP
 N: None P: 1m S: 3m M: 5m X □ □: Custom Length R □ □: Robot cable
 B: Brake NM: Reversed-home SR: Slider Roller

* See page Pre-35 for explanation of each code that makes up the configuration name.

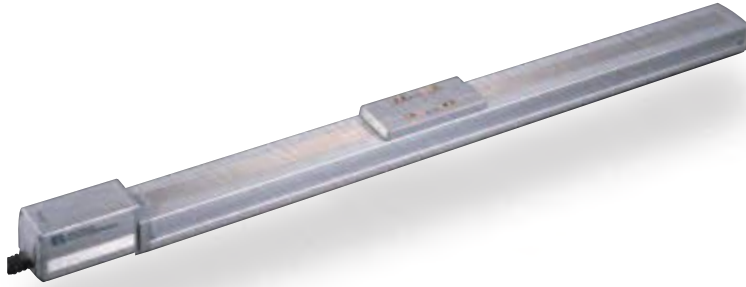

Technical References A-5

- POINT** Notes on Selection
- When the stroke increases, the maximum speed will drop to prevent the ball screw from reaching the critical rotational speed. Use the actuator specification table below to check the maximum speed at the stroke you desire.
 - Since the RCP2 series use a pulse motor, the load capacity decreases at high speeds. Check in the Speed vs. Load Capacity graph to see if your desired speed and load capacity are supported.
 - The load capacity is based on operation at an acceleration of 0.3G (0.2G for the 3mm-lead model, or when used vertically). These values are the upper limits for the acceleration.

■ Speed vs. Load Capacity
 Due to the characteristics of the pulse motor, the RCP2 series' load capacity decreases at high speeds. In the table below, check if your desired speed and load capacity are supported.

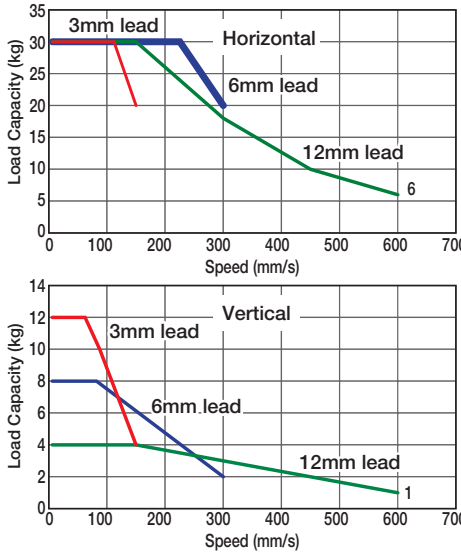

Actuator Specifications

■ Lead and Load Capacity (Note 1) Please note that the maximum load capacity decreases as the speed increases.

Model	Lead (mm)	Max. Load Capacity (Note 1)		Stroke (mm)
		Horizontal (kg)	Vertical (kg)	
RCP2-SS7C-I-42P-12-①-②-③-④	12	~ 30	~ 4	50 ~ 600 (50mm increments)
RCP2-SS7C-I-42P-6-①-②-③-④	6	~ 30	~ 8	
RCP2-SS7C-I-42P-3-①-②-③-④	3	~ 30	~ 12	

Legend ① Stroke ② Compatible controller ③ Cable length ④ Options

■ Stroke and Maximum Speed

Stroke / Lead	50 ~ 500 (50mm increments)	~ 600 (mm)
	12	600
6	300	230
3	150	115

(Unit: mm/s)

Cable List

Type	Cable Symbol
Standard	P (1m)
	S (3m)
	M (5m)
Special Lengths	X06 (6m) ~ X10 (10m)
	X11 (11m) ~ X15 (15m)
	X16 (16m) ~ X20 (20m)
Robot Cable	R01 (1m) ~ R03 (3m)
	R04 (4m) ~ R05 (5m)
	R06 (6m) ~ R10 (10m)
	R11 (11m) ~ R15 (15m)
	R16 (16m) ~ R20 (20m)

* See page A-39 for cables for maintenance.

Actuator Specifications

Item	Description
Drive System	Ball screw Ø10mm C10 grade
Positioning Repeatability	±0.02mm
Lost Motion	0.1 mm or less
Base	Material: Special alloy steel
Allowable Static Moment	Ma: 79.4 N·m Mb: 79.4 N·m Mc: 172.9 N·m
Allowable Dynamic Moment (*)	Ma: 14.7 N·m Mb: 14.7 N·m Mc: 33.3 N·m
Overhang Load Length	Ma direction: 300mm or less; Mb-Mc direction: 300mm or less
Ambient Operating Temp./Humidity	0~40°C, 85% RH or less (Non-condensing)

(*) Based on 10,000km travel life.

Directions of Allowable Load Moments

Option List

Name	Option Code	See Page
Brake	B	→ A-25
Reversed-home	NM	→ A-33
Slider Roller	SR	→ A-36

Dimensions

CAD drawings can be downloaded from IAI website. www.robocylinder.de

For Special Orders  A-9

2/3D CAD

*For the Reversed-home model, the dimensions (distance to home) on the motor-side and that on the opposite side are flipped.

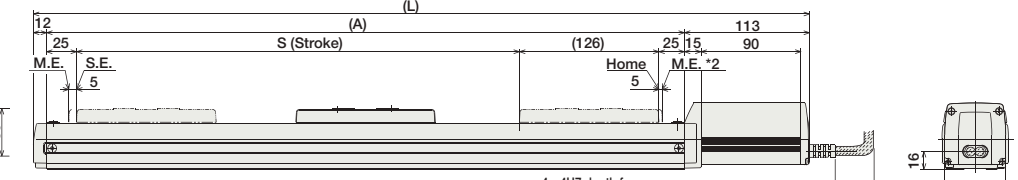
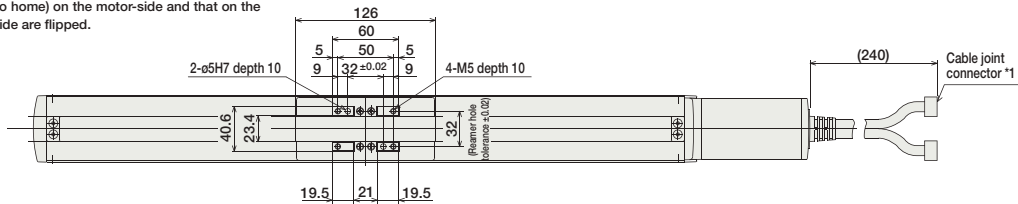
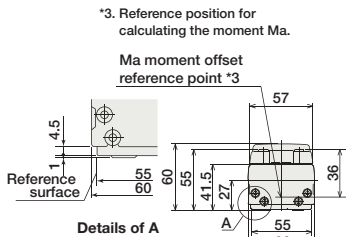

- *1: The motor-encoder cable is connected here. See page A-39 for details on cables.
- *2: When homing, the slider moves to the ME; therefore, please watch for any interference with the surrounding objects.
 ME: Mechanical end
 SE: Stroke end
 The dimensions enclosed in "()" are reference dimensions.

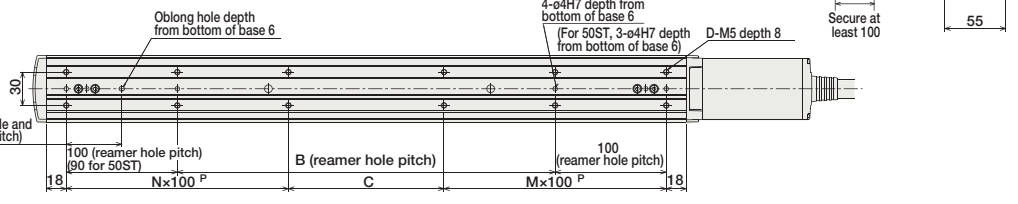

Dimensions of the brake section

* Adding a brake will increase the actuator's overall length by 24.5mm, and its weight by 0.3kg.

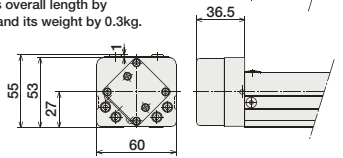







* Brake cable is passed through the actuator body and connected to the motor cable.

■ Dimensions/Weight by Stroke

Stroke	50	100	150	200	250	300	350	400	450	500	550	600
L	351	401	451	501	551	601	651	701	751	801	851	901
A	226	276	326	376	426	476	526	576	626	676	726	776
B	0	40	90	140	190	240	290	340	390	440	490	540
C	90	40	90	140	190	40	90	140	190	40	90	140
D	6	8	8	8	8	12	12	12	12	16	16	16
M	1	1	1	1	1	2	2	2	2	3	3	3
N	0	1	1	1	1	2	2	2	2	3	3	3
Weight (kg)	3.1	3.4	3.7	4.0	4.3	4.7	5.0	5.4	5.7	6.1	6.4	6.7

Compatible Controllers

The RCP2 series actuators can operate with the controllers below. Select the controller according to your usage.

Name	External View	Model	Description	Max. Positioning Points	Input Voltage	Power Supply Capacity	See Page
Solenoid Valve Type		PMEC-C-42PI-NP-2-2	Easy-to-use controller, even for beginners	3 points	AC115V AC230V	See P481	→ P477
		PSEP-C-42PI-NP-2-0	Operable with same signal as solenoid valve. Supports both single and double solenoid types. No homing necessary with simple absolute type.				→ P487
Splash-Proof Solenoid Valve Type		PSEP-CW-42PI-NP-2-0					
Positioner Type		PCON-C-42PI-NP-2-0	Positioning is possible for up to 512 points	512 points			
Safety-Compliant Positioner Type		PCON-CG-42PI-NP-2-0					
Pulse Train Input Type (Differential Line Driver)		PCON-PL-42PI-NP-2-0	Pulse train input type with differential line driver support	(-)	DC24V	2A max.	→ P525
Pulse Train Input Type (Open Collector)		PCON-PO-42PI-NP-2-0	Pulse train input type with open collector support				
Serial Communication Type		PCON-SE-42PI-N-0-0	Dedicated to serial communication	64 points			
Field Network Type		RPCON-42P	Dedicated to field network	768 points			→ P503
Program Control Type		PSEL-C-1-42PI-NP-2-0	Programmed operation is possible. Can operate up to 2 axes	1500 points			→ P557

* This is for the single-axis PSEL.

- Slider Type
- Mini
- Standard
- Controllers Integrated
- Rod Type
- Mini
- Standard
- Controllers Integrated
- Table/Arm /Flat Type
- Mini
- Standard
- Gripper/ Rotary Type
- Linear Motor Type
- Cleanroom Type
- Splash-Proof
- Controllers
- PMEC /AMEC
- PSEP /ASEP
- ROBO NET
- ERC2
- PCON
- ACON
- SCON
- PSEL
- ASEL
- SSEL
- XSEL
- Pulse Motor
- Servo Motor (24V)
- Servo Motor (230V)
- Linear Motor

RCP2-SS8C

RoboCylinder Slider Type 80mm Width Pulse Motor Straight Type Steel Base Coupled

■ Configuration: **RCP2** - **SS8C** - **I** - **56P** - [] - [] - [] - [] - []

Series - Type - Encoder - Motor - Lead - Stroke - Compatible Controllers - Cable Length - Option

I: Incremental 56P: Pulse motor 20: 20mm 50: 50mm P1: PCON N: None B: Brake
 * The Simple absolute encoder models are labeled as "I". 56 □ size 10: 10mm \ RPCON P: 1m NM: Reversed-home
 5: 5mm 1000: 1000mm (50mm pitch increments) P3: PMEAC M: 5m SR: Slider Roller
 X □ □: Custom Length PSEP
 R □ □: Robot cable

* See page Pre-35 for explanation of each code that makes up the configuration name.

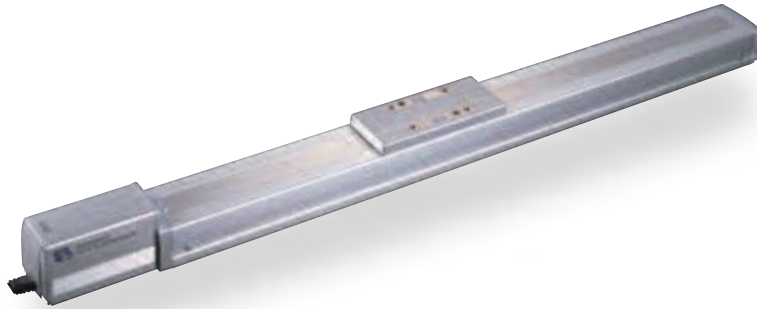

Technical References A-5

- POINT** Notes on Selection
- (1) When the stroke increases, the maximum speed will drop to prevent the ball screw from reaching the critical rotational speed. Use the actuator specification table below to check the maximum speed at the stroke you desire.
 - (2) Since the RCP2 series use a pulse motor, the load capacity decreases at high speeds. Check in the Speed vs. Load Capacity graph to see if your desired speed and load capacity are supported.
 - (3) The load capacity is based on operation at an acceleration of 0.3G (0.2G for the 5mm-lead model, or when used vertically). These values are the upper limits for the acceleration.

■ **Speed vs. Load Capacity**
 Due to the characteristics of the pulse motor, the RCP2 series' load capacity decreases at high speeds. In the table below, check if your desired speed and load capacity are supported.

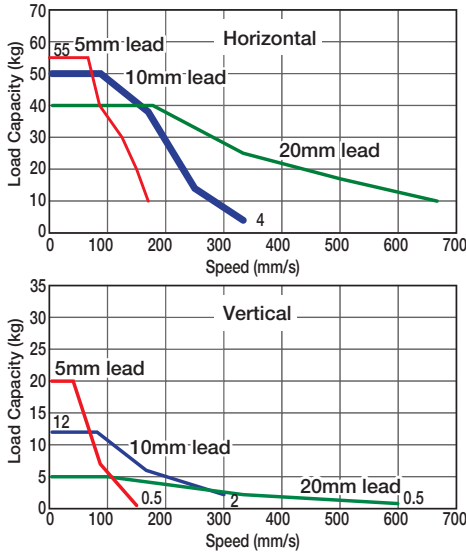

Actuator Specifications

(Note 1) Please note that the maximum load capacity decreases as the speed increases.

■ **Lead and Load Capacity**

Model	Lead (mm)	Max. Load Capacity (Note 1)		Stroke (mm)
		Horizontal (kg)	Vertical (kg)	
RCP2-SS8C-I-56P-20-①-②-③-④	20	~ 40	~ 5	50 ~ 1000 (50mm increments)
RCP2-SS8C-I-56P-10-①-②-③-④	10	~ 50	~ 12	
RCP2-SS8C-I-56P-5-①-②-③-④	5	~ 55	~ 20	

Legend ① Stroke ② Compatible controller ③ Cable length ④ Options

■ **Stroke and Maximum Speed**

Stroke / Lead	50 ~ 800	~ 900	~ 1000
	(50mm increments)	(mm)	(mm)
20	666 <600>	625 <600>	515
10	333 <300>	310 <300>	255
5	165 <150>	155 <150>	125

* The values enclosed in < > apply to vertical setting. (Unit: mm/s)

Cable List

Type	Cable Symbol
Standard	P (1m)
	S (3m)
	M (5m)
Special Lengths	X06 (6m) ~ X10 (10m)
	X11 (11m) ~ X15 (15m)
	X16 (16m) ~ X20 (20m)
Robot Cable	R01 (1m) ~ R03 (3m)
	R04 (4m) ~ R05 (5m)
	R06 (6m) ~ R10 (10m)
	R11 (11m) ~ R15 (15m)
	R16 (16m) ~ R20 (20m)

* See page A-39 for cables for maintenance.

Actuator Specifications

Item	Description
Drive System	Ball screw ø16mm C10 grade
Positioning Repeatability	±0.02mm
Lost Motion	0.1 mm or less
Base	Material: Special alloy steel
Allowable Static Moment	Ma: 198.9 N·m Mb: 198.9 N·m Mc: 416.7 N·m
Allowable Dynamic Moment (*)	Ma: 36.3 N·m Mb: 36.3 N·m Mc: 77.4 N·m
Overhang Load Length	Ma direction: 450mm or less; Mb-Mc direction: 450mm or less
Ambient Operating Temp./Humidity	0~40°C, 85% RH or less (Non-condensing)

(*) Based on 10,000km travel life.
 Directions of Allowable Load Moments

Option List

Name	Option Code	See Page
Brake	B	→ A-25
Reversed-home	NM	→ A-33
Slider Roller	SR	→ A-36

- Slider Type
- Mini
- Standard
- Controllers Integrated
- Rod Type
- Mini
- Standard
- Controllers Integrated
- Table/Arm /Flat Type
- Mini
- Standard
- Gripper/ Rotary Type
- Linear Motor Type
- Cleanroom Type
- Splash-Proof
- Controllers
- PMEC /AMEC
- PSEP /ASEP
- ROBO NET
- ERC2
- PCON
- ACON
- SCON
- PSEL
- ASEL
- SSEL
- XSEL
- Pulse Motor
- Servo Motor (24V)
- Servo Motor (230V)
- Linear Motor

Dimensions

CAD drawings can be downloaded from IAI website. www.robocylinder.de



*For the reversed-home model, the dimensions (distance to home) on the motor-side and that on the opposite side are flipped.

For Special Orders A-9

*3. Reference position for calculating the moment Ma.

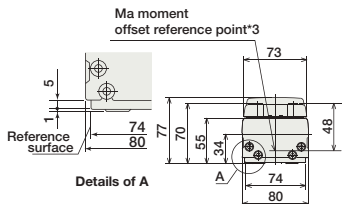

- *1: The motor-encoder cable is connected here. See page A-39 for details on cables.
- *2: When homing, the slider moves to the ME; therefore, please watch for any interference with the surrounding objects.
ME: Mechanical end
SE: Stroke end
The dimensions enclosed in "()" are reference dimensions.

Dimensions of the brake section

* Adding a brake will increase the actuator's overall length by 26mm, and its weight by 0.5kg.

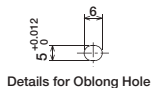
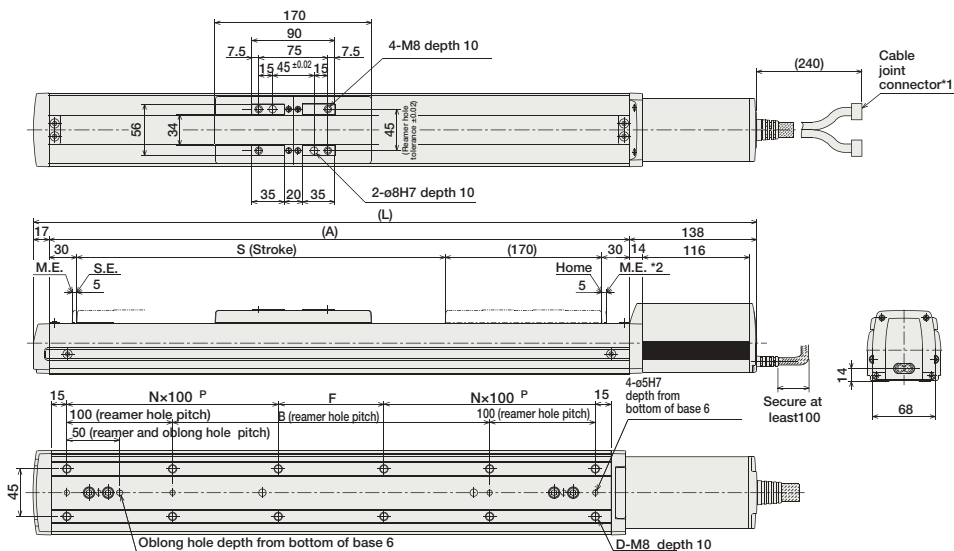
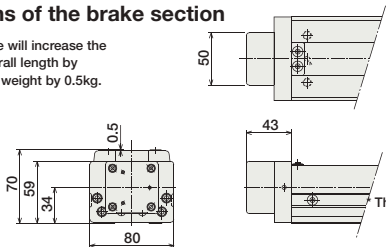

The brake cable is passed through the actuator body and connected to the motor cable.

Dimensions/Weight by Stroke

Stroke	50	100	150	200	250	300	350	400	450	500	550	600	650	700	750	800	850	900	950	1000
L	435	485	535	585	635	685	735	785	835	885	935	985	1035	1085	1135	1185	1235	1285	1335	1385
A	280	330	380	430	480	530	580	630	680	730	780	830	880	930	980	1030	1080	1130	1180	1230
B	50	100	150	200	250	300	350	400	450	500	550	600	650	700	750	800	850	900	950	1000
D	8	8	8	10	12	12	12	14	16	16	16	18	20	20	20	22	24	24	24	26
F	50	100	150	0	50	100	150	0	50	100	150	0	50	100	150	0	50	100	150	0
N	1	1	1	2	2	2	2	3	3	3	3	4	4	4	4	5	5	5	5	6
Weight (kg)	6.6	7.1	7.6	8.1	8.6	9.2	9.7	10.2	10.7	11.3	11.7	12.3	12.8	13.4	13.9	14.5	15.0	15.5	16.1	16.6

Compatible Controllers

The RCP2 series actuators can operate with the controllers below. Select the controller according to your usage.

Name	External View	Model	Description	Max. Positioning Points	Input Voltage	Power Supply Capacity	See Page
Solenoid Valve Type		PMEC-C-56PI-NP-2-2	Easy-to-use controller, even for beginners	3 points	AC115V AC230V	See P481	→ P477
		PSEP-C-56PI-NP-2-0	Operable with same signal as solenoid valve. Supports both single and double solenoid types. No homing necessary with simple absolute type.				
Splash-Proof Solenoid Valve Type		PSEP-CW-56PI-NP-2-0					
Positioner Type		PCON-C-56PI-NP-2-0	Positioning is possible for up to 512 points	512 points	DC24V	2A max.	
Safety-Compliant Positioner Type		PCON-CG-56PI-NP-2-0					
Pulse Train Input Type (Differential Line Driver)		PCON-PL-56PI-NP-2-0	Pulse train input type with differential line driver support	(-)	DC24V	2A max.	→ P525
Pulse Train Input Type (Open Collector)		PCON-PO-56PI-NP-2-0	Pulse train input type with open collector support				
Serial Communication Type		PCON-SE-56PI-N-0-0	Dedicated to serial communication	64 points			
Field Network Type		RPCON-56P	Dedicated to field network	768 points			→ P503
Program Control Type		PSEL-C-1-56PI-NP-2-0	Programmed operation is possible Can operate up to 2 axes	1500 points			→ P557

* This is for the single-axis PSEL.

- Slider Type
- Mini
- Standard
- Controllers Integrated
- Rod Type
- Mini
- Standard
- Controllers Integrated
- Table/Arm /Flat Type
- Mini
- Standard
- Gripper/ Rotary Type
- Linear Motor Type
- Cleanroom Type
- Splash-Proof
- Controllers
- PMEC /AMEC
- PSEP /ASEP
- ROBO NET
- ERC2
- PCON
- ACON
- SCON
- PSEL
- ASEL
- SSEL
- XSEL
- Pulse Motor
- Servo Motor (24V)
- Servo Motor (230V)
- Linear Motor

RCP2-HS8C RoboCylinder High-Speed Slider Type 80mm Width Pulse Motor Straight Type

Steel Base Coupled

■ Configuration: **RCP2** — **HS8C** — **I** — **86P** — — — **P2** — —

Series — Type — Encoder — Motor — Lead — Stroke — Compatible Controllers — Cable Length — Option

I: Incremental 86P: Pulse motor
56 high output

30:30mm 50: 50mm
1000:1000mm
(50mm pitch increments)

P2:PCON-CF N : None B : Brake
P : 1m P : 1m NM: Reversed-home
S : 3m M : 5m SR : Slider Roller
X : Custom Length
R : Robot cable

* See page Pre-35 for explanation of each code that makes up the configuration name.

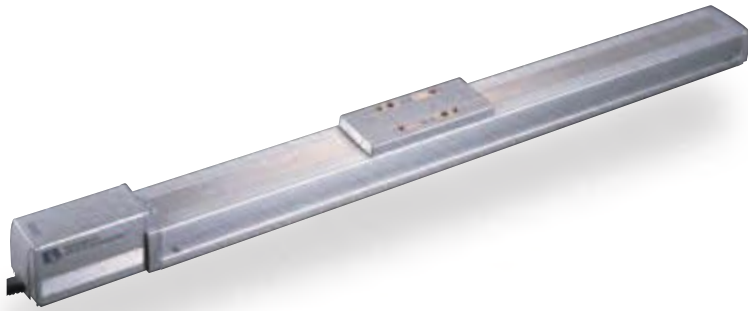

Technical References A-5

- POINT** Notes on Selection
- Due to the large lead of the ball screw in high-speed actuators, operating at low speeds may cause vibration and/or noise. Therefore, use the actuator at speeds over 100mm/s.
 - When the stroke increases, the maximum speed will drop to prevent the ball screw from reaching the critical rotational speed. Use the actuator specification table below to check the maximum speed at the stroke you desire.
 - Since the RCP2 series use a pulse motor, the load capacity decreases at high speeds. Check in the Speed vs. Load Capacity graph to see if your desired speed and load capacity are supported.
 - The load capacity is based on operation at an acceleration of 0.3G (0.2G when used vertically). The upper limit for the acceleration is 0.5G for horizontal use and 0.2G for vertical use.

■ Speed vs. Load Capacity
Due to the characteristics of the pulse motor, the RCP2 series' load capacity decreases at high speeds. In the table below, check if your desired speed and load capacity are supported.

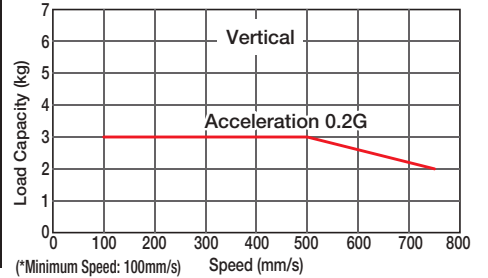
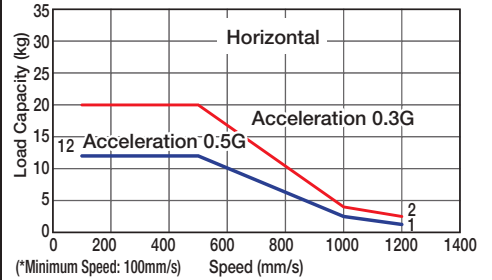

Actuator Specifications

■ Lead and Load Capacity (Note 1) Please note that the maximum load capacity decreases as the speed increases.

Model	Lead (mm)	Max. Load Capacity (Note 1)		Stroke (mm)
		Horizontal (kg)	Vertical (kg)	
RCP2-HS8C-I-86P-30-①-P2-②-③	30	~ 20	~ 3	50 ~ 1000 (50mm increments)

Legend ① Stroke ② Cable length ③ Options

■ Stroke and Maximum Speed

Stroke / Lead	50 ~ 800 (50mm increments)	~ 900 (mm)	~ 1000 (mm)
	30	1200 <750>	1000 <750>

* The values enclosed in < > apply to vertical setting. (Unit: mm/s)

Cable List

Type	Cable Symbol
Standard	P (1m)
	S (3m)
	M (5m)
Special Lengths	X06 (6m) ~ X10 (10m)
	X11 (11m) ~ X15 (15m)
	X16 (16m) ~ X20 (20m)
Robot Cable	R01 (1m) ~ R03 (3m)
	R04 (4m) ~ R05 (5m)
	R06 (6m) ~ R10 (10m)
	R11 (11m) ~ R15 (15m)
	R16 (16m) ~ R20 (20m)

* See page A-39 for cables for maintenance.

Option List

Name	Option Code	See Page
Brake	B	→ A-25
Reversed-home	NM	→ A-33
Slider Roller	SR	→ A-36

Actuator Specifications

Item	Description
Drive System	Ball screw ϕ 16mm C10 grade
Positioning Repeatability	\pm 0.02mm
Lost Motion	0.1mm or less
Base	Material: Special alloy steel
Allowable Static Moment	Ma: 198.9 N·m Mb: 198.9 N·m Mc: 416.7 N·m
Allowable Dynamic Moment (*)	Ma: 36.3 N·m Mb: 36.3 N·m Mc: 77.4 N·m
Overhang Load Length	Ma direction: 450mm or less; Mb-Mc direction: 450mm or less
Ambient Operating Temp./Humidity	0~40°C, 85% RH or less (Non-condensing)

(*) Based on 10,000km travel life.

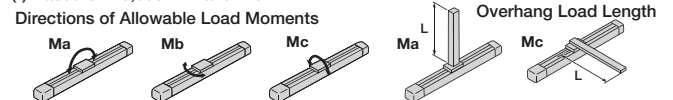

Dimensions

CAD drawings can be downloaded from IAI website. www.robocylinder.de



* For the reversed-home model, the dimensions (distance to home) on the motor-side and that on the opposite side are flipped.

For Special Orders A-9

*3. Reference position for calculating the moment M_a .

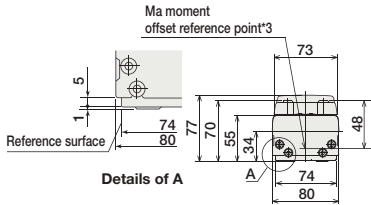

*1: The motor-encoder cable is connected here. See page A-39 for details on cables.

*2: When homing, the slider moves to the ME; therefore, please watch for any interference with the surrounding objects.

ME: Mechanical end
SE: Stroke end

The dimensions enclosed in "()" are reference dimensions.

Dimensions of the brake section

* Adding a brake will increase the actuator's overall length by 26mm, and its weight by 0.5kg.

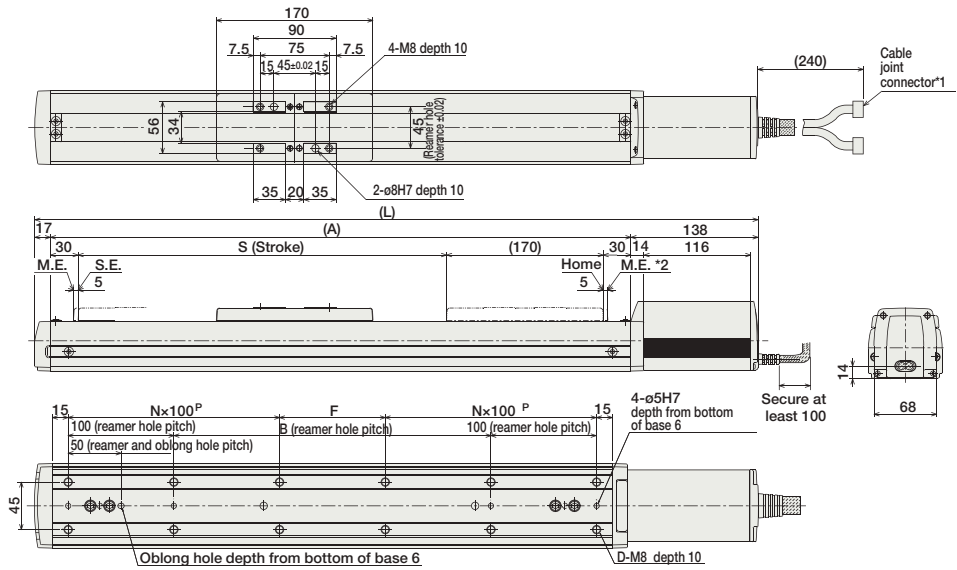
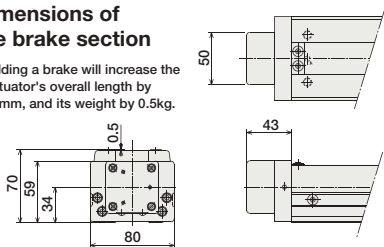

* The brake cable is passed through the actuator body and connected to the motor cable.

■ Dimensions/Weight by Stroke

Stroke	50	100	150	200	250	300	350	400	450	500	550	600	650	700	750	800	850	900	950	1000
L	435	485	535	585	635	685	735	785	835	885	935	985	1035	1085	1135	1185	1235	1285	1335	1385
A	280	330	380	430	480	530	580	630	680	730	780	830	880	930	980	1030	1080	1130	1180	1230
B	50	100	150	200	250	300	350	400	450	500	550	600	650	700	750	800	850	900	950	1000
D	8	8	8	10	12	12	12	14	16	16	16	18	20	20	20	22	24	24	24	26
F	50	100	150	0	50	100	150	0	50	100	150	0	50	100	150	0	50	100	150	0
N	1	1	1	2	2	2	3	3	3	4	4	4	4	4	5	5	5	5	5	6
Weight (kg)	6.6	7.1	7.6	8.1	8.6	9.2	9.7	10.2	10.7	11.3	11.7	12.3	12.8	13.4	13.9	14.5	15.0	15.5	16.1	16.6

Compatible Controllers

The controller for the RCP2-HS8C type is a dedicated controller.

Name	External View	Model	Description	Max. Positioning Points	Input Voltage	Power Supply Capacity	See Page
Positioner Type		PCON-CF-86PI-NP-2-0	Positioning is possible for up to 512 points	512 points	DC24V	6A max.	→ P525

Note: • Please note that the encoder cable is a dedicated CF-type cable that is different from the PCON-C/CG/CY/PL/PO/SE controllers.
• Note that a simple absolute unit cannot be used.

Slider Type

Mini

Standard

Controllers Integrated

Rod Type

Mini

Standard

Controllers Integrated

Table/Arm /Flat Type

Mini

Standard

Gripper/ Rotary Type

Linear Motor Type

Cleanroom Type

Splash-Proof

Controllers

PMEC /AMEC

PSEP /ASEP

ROBO NET

ERC2

PCON

ACON

SCON

PSEL

ASEL

SSEL

XSEL

Pulse Motor

Servo Motor (24V)

Servo Motor (230V)

Linear Motor

- Slider Type
- Mini
- Standard
- Controllers Integrated
- Rod Type
- Mini
- Standard
- Controllers Integrated
- Table/Arm /Flat Type
- Mini
- Standard
- Gripper/ Rotary Type
- Linear Motor Type
- Cleanroom Type
- Splash-Proof
- Controllers
- PMEC /AMEC
- PSEP /ASEP
- ROBO NET
- ERC2
- PCON
- ACON
- SCON
- PSEL
- ASEL
- SSEL
- XSEL
- Pulse Motor
- Servo Motor (24V)
- Servo Motor (230V)
- Linear Motor

RCP2-SA5R RoboCylinder Slider Type 52mm Width Pulse Motor Side-Mounted Motor

■ Configuration: **RCP2** - **SA5R** - **I** - **42P** - [] - [] - [] - [] - []

Series — Type — Encoder — Motor — Lead — Stroke — Compatible Controllers — Cable Length — Option

I: Incremental 42P: Pulse motor 12: 12mm 50: 50mm P1: PCON N: None See Options below
 * The Simple absolute encoder models are labeled as "I". 42 □ size 6: 6mm 800: 800mm (50mm pitch increments) RPCON P: 1m * Be sure to specify which side the motor is to be mounted (ML/MR).
 PSEL M: 5m X □ □ : Custom Length
 P3: PMEAC PSEP R □ □ : Robot cable

* See page Pre-35 for explanation of each code that makes up the configuration name.

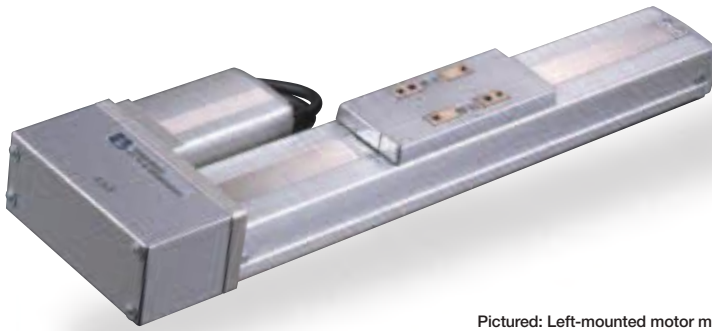

Pictured: Left-mounted motor model (ML).

Technical References A-5

- POINT**
Notes on Selection
- When the stroke increases, the maximum speed will drop to prevent the ball screw from reaching the critical rotational speed. Use the actuator specification table below to check the maximum speed at the stroke you desire.
 - Since the RCP2 series use a pulse motor, the load capacity decreases at high speeds. Check in the Speed vs. Load Capacity graph to see if your desired speed and load capacity are supported.
 - The load capacity is based on operation at an acceleration of 0.3G (0.2G for the 3mm-lead model, or when used vertically). These values are the upper limits for the acceleration.

■ Speed vs. Load Capacity
 Due to the characteristics of the pulse motor, the RCP2 series' load capacity decreases at high speeds. In the table below, check if your desired speed and load capacity are supported.

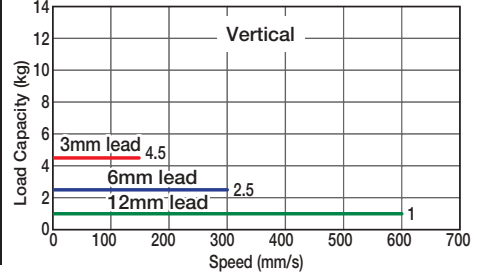
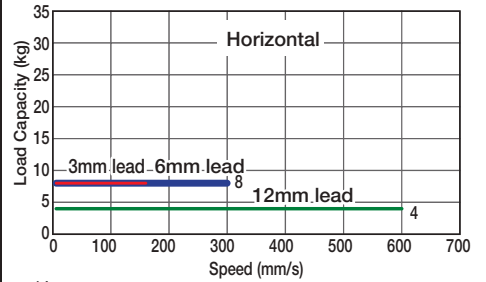

Actuator Specifications

Lead and Load Capacity

(Note 1) Please note that the maximum load capacity decreases as the speed increases.

Model	Lead (mm)	Max. Load Capacity (Note 1)		Stroke (mm)
		Horizontal (kg)	Vertical (kg)	
RCP2-SA5R-I-42P-12-①-②-③-④	12	4	1	50 ~ 800 (50mm increments)
RCP2-SA5R-I-42P-6-①-②-③-④	6	8	2.5	
RCP2-SA5R-I-42P-3-①-②-③-④	3	8	4.5	

Legend ① Stroke ② Compatible controller ③ Cable length ④ Options

Stroke and Maximum Speed

Stroke / Lead	50 ~ 550	600	650	700	750	800
	(50mm increments)	(mm)	(mm)	(mm)	(mm)	(mm)
12	600	540	460	400	360	300
6	300	270	230	200	180	150
3	150	135	115	100	90	75

(Unit: mm/s)

Cable List

Type	Cable Symbol
Standard	P (1m)
	S (3m)
	M (5m)
Special Lengths	X06 (6m) ~ X10 (10m)
	X11 (11m) ~ X15 (15m)
	X16 (16m) ~ X20 (20m)
	R01 (1m) ~ R03 (3m)
Robot Cable	R04 (4m) ~ R05 (5m)
	R06 (6m) ~ R10 (10m)
	R11 (11m) ~ R15 (15m)
	R16 (16m) ~ R20 (20m)

* See page A-39 for cables for maintenance.

Option List

Name	Option Code	See Page
Brake	B	→ A-25
Reversed-home	NM	→ A-33
Left-Mounted Motor (Standard)	ML	→ A-33
Right-Mounted Motor	MR	→ A-33
Slider Roller	SR	→ A-36

Actuator Specifications

Item	Description
Drive System	Ball screw Ø10mm C10 grade
Positioning Repeatability	±0.02mm
Lost Motion	0.1mm or less
Base	Material: Aluminum (white alumite treated)
Allowable Static Moment	Ma: 18.6 N·m Mb: 26.6 N·m Mc: 47.5 N·m
Allowable Dynamic Moment (*)	Ma: 4.9 N·m Mb: 6.8 N·m Mc: 11.7 N·m
Overhang Load Length	Ma direction: 150mm or less; Mb-Mc direction: 150mm or less
Ambient Operating Temp./Humidity	0~40°C, 85% RH or less (Non-condensing)

(*) Based on 5,000km travel life.

Directions of Allowable Load Moments

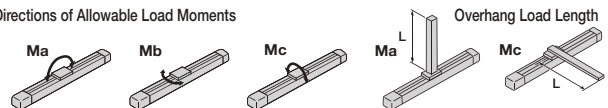

Dimensions

CAD drawings can be downloaded from IAI website. www.robocylinder.de



*For the reversed-home model, the dimensions (distance to home) on the motor-side and that on the opposite side are flipped.

For Special Orders A-9

- The motor-encoder cable is connected here. See page A-39 for details on cables.
- When homing, the slider moves to the ME; therefore, please watch for any interference with the surrounding objects.
ME: Mechanical end
SE: Stroke end
The values enclosed in "() " are reference dimensions.

* The offset reference position for the moment Ma is the same as the SA5 type. (See P28)

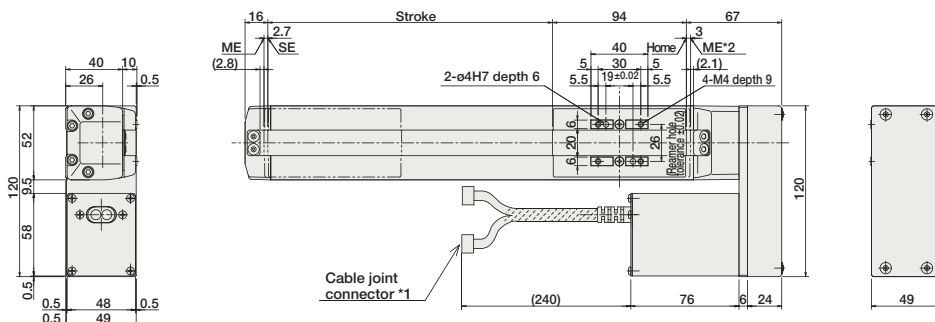

Dimensions of the brake section

* Adding a brake will increase the actuator's overall length by 40mm, and its weight by 0.4kg.

Mounting direction: symmetrically opposite

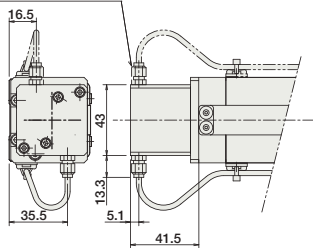

* For brake cable exiting from the side, it can only exit from the motor side.

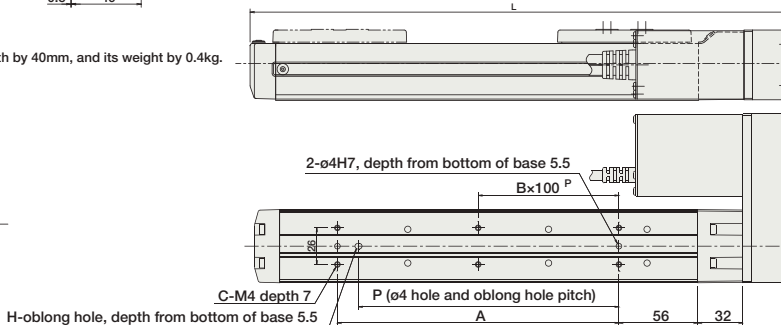

Details for Oblong Hole

■ Dimensions/Weight by Stroke

Stroke	50	100	150	200	250	300	350	400	450	500	550	600	650	700	750	800
L	227	277	327	377	427	477	527	577	627	677	727	777	827	877	927	977
A	73	100	100	200	200	300	300	400	400	500	500	600	600	700	700	800
B	0	0	0	1	1	2	2	3	3	4	4	5	5	6	6	7
C	4	4	4	6	6	8	8	10	10	12	12	14	14	16	16	18
H	0	1	1	1	1	1	1	1	1	1	1	1	1	1	1	1
P	0	85	85	185	185	285	285	385	385	485	485	585	585	685	685	785
Weight (kg)	2.0	2.1	2.2	2.3	2.4	2.6	2.7	2.8	2.9	3.0	3.1	3.3	3.4	3.5	3.6	3.7

Compatible Controllers

The RCP2 series actuators can operate with the controllers below. Select the controller according to your usage.

Name	External View	Model	Description	Max. Positioning Points	Input Voltage	Power Supply Capacity	See Page
Solenoid Valve Type		PMEC-C-42PI-NP-2-2	Easy-to-use controller, even for beginners	3 points	AC115V AC230V	See P481	→ P477
		PSEP-C-42PI-NP-2-0	Operable with same signal as solenoid valve. Supports both single and double solenoid types. No homing necessary with simple absolute type.				→ P487
Splash-Proof Solenoid Valve Type		PSEP-CW-42PI-NP-2-0					
Positioner Type		PCON-C-42PI-NP-2-0	Positioning is possible for up to 512 points	512 points			
Safety-Compliant Positioner Type		PCON-CG-42PI-NP-2-0					
Pulse Train Input Type (Differential Line Driver)		PCON-PL-42PI-NP-2-0	Pulse train input type with differential line driver support	(-)	DC24V	2A max.	→ P525
Pulse Train Input Type (Open Collector)		PCON-PO-42PI-NP-2-0	Pulse train input type with open collector support				
Serial Communication Type		PCON-SE-42PI-N-0-0	Dedicated to serial communication	64 points			
Field Network Type		RPCON-42P	Dedicated to field network	768 points			→ P503
Program Control Type		PSEL-C-1-42PI-NP-2-0	Programmed operation is possible. Can operate up to 2 axes	1500 points			→ P557

* This is for the single-axis PSEL.

- Slider Type
- Mini
- Standard
- Controllers Integrated
- Rod Type
- Mini
- Standard
- Controllers Integrated
- Table/Arm /Flat Type
- Mini
- Standard
- Gripper/ Rotary Type
- Linear Motor Type
- Cleanroom Type
- Splash-Proof
- Controllers
- PMEC /AMEC
- PSEP /ASEP
- ROBO NET
- ERC2
- PCON
- ACON
- SCON
- PSEL
- ASEL
- SSEL
- XSEL
- Pulse Motor
- Servo Motor (24V)
- Servo Motor (200V)
- Linear Motor

- Slider Type
- Mini
- Standard
- Controllers Integrated
- Rod Type
- Mini
- Standard
- Controllers Integrated
- Table/Arm /Flat Type
- Mini
- Standard
- Gripper/ Rotary Type
- Linear Motor Type
- Cleanroom Type
- Splash-Proof
- Controllers
- PMEC /AMEC
- PSEP /ASEP
- ROBO NET
- ERC2
- PCON
- ACON
- SCON
- PSEL
- ASEL
- SSEL
- XSEL
- Pulse Motor
- Servo Motor (24V)
- Servo Motor (230V)
- Linear Motor

RCP2-SA6R

RoboCylinder Slider Type 58mm Width Pulse Motor Side-Mounted Motor

■ Configuration: **RCP2 - SA6R - I - 42P** - [] - [] - [] - [] - []

Series — Type — Encoder — Motor — Lead — Stroke — Compatible Controllers — Cable Length — Option

I: Incremental 42P: Pulse motor 12: 12mm 50: 50mm P1: PCON N: None See Options below
 * The Simple absolute encoder models are labeled as "I". 42 □ size 6: 6mm \ RPCON P: 1m * Be sure to specify which side the motor is to be mounted (ML/MR).
 3: 3mm 800: 800mm (50mm pitch increments) PSEL S: 3m M: 5m X □ □: Custom Length
 P3: PMEAC PSEP R □ □: Robot cable

* See page Pre-35 for explanation of each code that makes up the configuration name.



Pictured: Left-mounted motor model (ML).

Technical References A-5

- POINT** Notes on Selection
- When the stroke increases, the maximum speed will drop to prevent the ball screw from reaching the critical rotational speed. Use the actuator specification table below to check the maximum speed at the stroke you desire.
 - Since the RCP2 series use a pulse motor, the load capacity decreases at high speeds. Check in the Speed vs. Load Capacity graph to see if your desired speed and load capacity are supported.
 - The load capacity is based on operation at an acceleration of 0.3G (0.2G for the 3mm-lead model, or when used vertically). These values are the upper limits for the acceleration.

■ Speed vs. Load Capacity
 Due to the characteristics of the pulse motor, the RCP2 series' load capacity decreases at high speeds. In the table below, check if your desired speed and load capacity are supported.

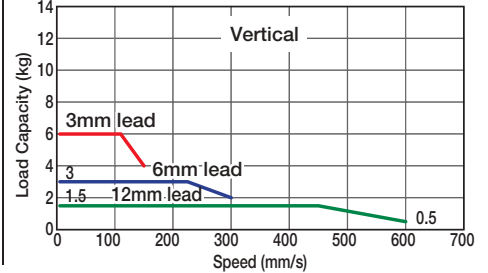
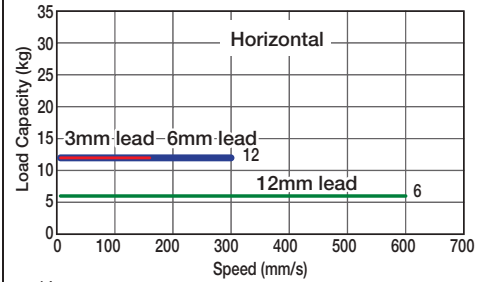

Actuator Specifications

Lead and Load Capacity

(Note 1) Please note that the maximum load capacity decreases as the speed increases.

Model	Lead (mm)	Max. Load Capacity (Note 1)		Stroke (mm)
		Horizontal (kg)	Vertical (kg)	
RCP2-SA6R-I-42P-12-①-②-③-④	12	6	~ 1.5	50 ~ 800 (50mm increments)
RCP2-SA6R-I-42P-6-①-②-③-④	6	12	~ 3	
RCP2-SA6R-I-42P-3-①-②-③-④	3	12	~ 6	

Legend ① Stroke ② Compatible controller ③ Cable length ④ Options

Stroke and Maximum Speed

Stroke / Lead	50 ~ 550 (50mm increments)	600 (mm)	650 (mm)	700 (mm)	750 (mm)	800 (mm)
	12	600	540	460	400	360
6	300	270	230	200	180	150
3	150	135	115	100	90	75

(Unit: mm/s)

Cable List

Type	Cable Symbol
Standard	P (1m)
	S (3m)
	M (5m)
Special Lengths	X06 (6m) ~ X10 (10m)
	X11 (11m) ~ X15 (15m)
	X16 (16m) ~ X20 (20m)
Robot Cable	R01 (1m) ~ R03 (3m)
	R04 (4m) ~ R05 (5m)
	R06 (6m) ~ R10 (10m)
	R11 (11m) ~ R15 (15m)
	R16 (16m) ~ R20 (20m)

* See page A-39 for cables for maintenance.

Option List

Name	Option Code	See Page
Brake	B	→ A-25
Reversed-home	NM	→ A-33
Left-Mounted Motor (Standard)	ML	→ A-33
Right-Mounted Motor	MR	→ A-33
Slider Roller	SR	→ A-36

Actuator Specifications

Item	Description
Drive System	Ball screw Ø10mm C10 grade
Positioning Repeatability	±0.02mm
Lost Motion	0.1mm or less
Base	Material: Aluminum (white alumite treated)
Allowable Static Moment	Ma: 38.3 N·m Mb: 54.7 N·m Mc: 81.0 N·m
Allowable Dynamic Moment (*)	Ma: 8.9 N·m Mb: 12.7 N·m Mc: 18.6 N·m
Overhang Load Length	Ma direction: 220mm or less; Mb-Mc direction: 220mm or less
Ambient Operating Temp./Humidity	0~40°C, 85% RH or less (Non-condensing)

(*) Based on 5,000km travel life.

Directions of Allowable Load Moments

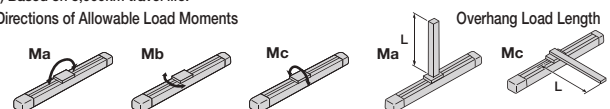

Dimensions

CAD drawings can be downloaded from IAI website. www.robocylinder.de

For Special Orders  A-9



*For the reversed-home model, the dimensions (distance to home) on the motor-side and that on the opposite side are flipped.

- *1. The motor-encoder cable is connected here. See page A-39 for details on cables.
- *2. When homing, the slider moves to the ME; therefore, please watch for any interference with the surrounding objects.
ME: Mechanical end
SE: Stroke end
The values enclosed in "()" are reference dimensions.

*The offset reference position for the moment Ma is the same as the SA6 type. (See P30)

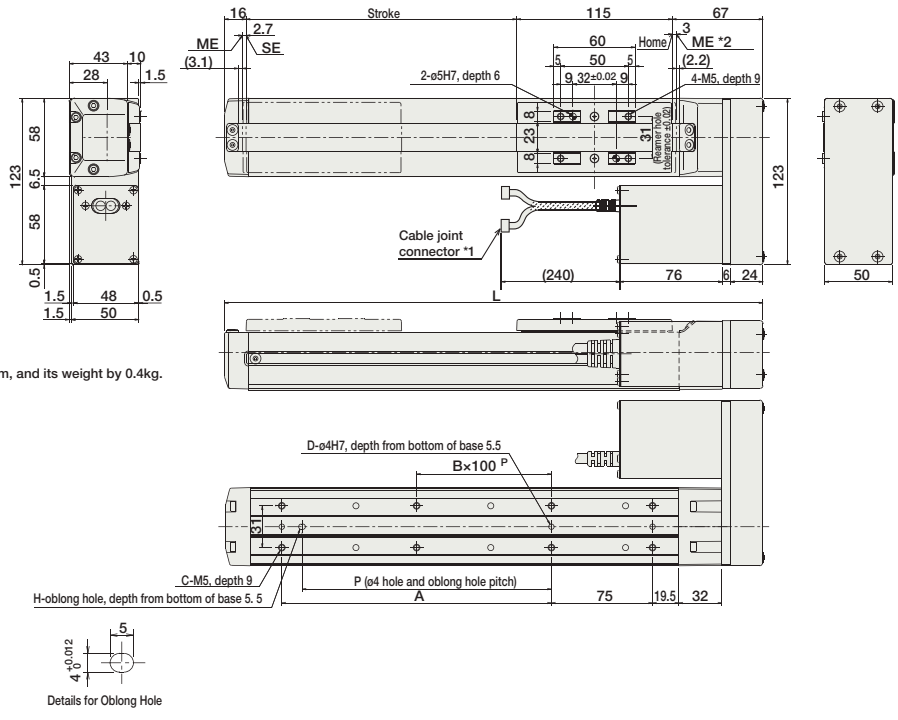

Dimensions of the brake section

* Adding a brake will increase the actuator's overall length by 40mm, and its weight by 0.4kg.

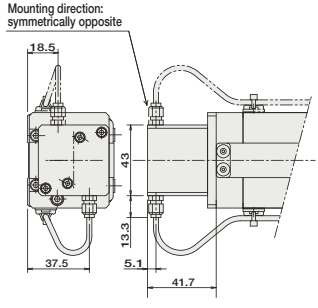

* For brake cable exiting from the side, it can only exit from the motor side.

■ Dimensions/Weight by Stroke

Stroke	50	100	150	200	250	300	350	400	450	500	550	600	650	700	750	800
L	248	298	348	398	448	498	548	598	648	698	748	798	848	898	948	998
A	0	100	100	200	200	300	300	400	400	500	500	600	600	700	700	800
B	0	0	0	1	1	2	2	3	3	4	4	5	5	6	6	7
C	4	6	6	8	8	10	10	12	12	14	14	16	16	18	18	20
D	2	3	3	3	3	3	3	3	3	3	3	3	3	3	3	3
H	0	1	1	1	1	1	1	1	1	1	1	1	1	1	1	1
P	0	85	85	185	185	285	285	385	385	485	485	585	585	685	685	785
Weight (kg)	2.3	2.5	2.6	2.7	2.9	3.0	3.2	3.3	3.4	3.6	3.7	3.9	4.0	4.1	4.3	4.4

Compatible Controllers

The RCP2 series actuators can operate with the controllers below. Select the controller according to your usage.

Name	External View	Model	Description	Max. Positioning Points	Input Voltage	Power Supply Capacity	See Page
Solenoid Valve Type		PMEC-C-42PI-NP-2-2	Easy-to-use controller, even for beginners	3 points	AC115V AC230V	See P481	→ P477
		PSEP-C-42PI-NP-2-0	Operable with same signal as solenoid valve. Supports both single and double solenoid types. No homing necessary with simple absolute type.				
Splash-Proof Solenoid Valve Type		PSEP-CW-42PI-NP-2-0					
Positioner Type		PCON-C-42PI-NP-2-0	Positioning is possible for up to 512 points	512 points			
Safety-Compliant Positioner Type		PCON-CG-42PI-NP-2-0					
Pulse Train Input Type (Differential Line Driver)		PCON-PL-42PI-NP-2-0	Pulse train input type with differential line driver support	(-)	DC24V	2A max.	→ P525
Pulse Train Input Type (Open Collector)		PCON-PO-42PI-NP-2-0	Pulse train input type with open collector support				
Serial Communication Type		PCON-SE-42PI-N-0-0	Dedicated to serial communication	64 points			
Field Network Type		RPCON-42P	Dedicated to field network	768 points			→ P503
Program Control Type		PSEL-C-1-42PI-NP-2-0	Programmed operation is possible. Can operate up to 2 axes	1500 points			→ P557

* This is for the single-axis PSEL.

- Slider Type
- Mini
- Standard
- Controllers Integrated
- Rod Type
- Mini
- Standard
- Controllers Integrated
- Table/Arm /Flat Type
- Mini
- Standard
- Gripper/ Rotary Type
- Linear Motor Type
- Cleanroom Type
- Splash-Proof
- Controllers
- PMEC /AMEC
- PSEP /ASEP
- ROBO NET
- ERC2
- PCON
- ACON
- SCON
- PSEL
- ASEL
- SSEL
- XSEL
- Pulse Motor
- Servo Motor (24V)
- Servo Motor (230V)
- Linear Motor

- Slider Type
- Mini
- Standard
- Controllers Integrated
- Rod Type
- Mini
- Standard
- Controllers Integrated
- Table/Arm /Flat Type
- Mini
- Standard
- Gripper/ Rotary Type
- Linear Motor Type
- Cleanroom Type
- Splash-Proof
- Controllers
- PMEC /AMEC
- PSEP /ASEP
- ROBO NET
- ERC2
- PCON
- ACON
- SCON
- PSEL
- ASEL
- SSEL
- XSEL
- Pulse Motor
- Servo Motor (24V)
- Servo Motor (230V)
- Linear Motor

RCP2-SA7R RoboCylinder Slider Type 73mm Width Pulse Motor Side-Mounted Motor

■ Configuration: **RCP2 - SA7R - I - 56P -**

Series Type Encoder Motor Lead Stroke Compatible Controllers Cable Length Option

I: Incremental 56P: Pulse motor 16: 16mm 50: 50mm P1: PCON N: None See Options below
 * The Simple absolute encoder models are labeled as "I". 56 □ size 8: 8mm \ RPCON P: 1m * Be sure to specify which side the motor is to be mounted (ML/MR).
 4: 4mm 800: 800mm (50mm pitch increments) P3: PMEAC M: 5m X □ □ : Custom Length
 R □ □ : Robot cable

* See page Pre-35 for explanation of each code that makes up the configuration name.

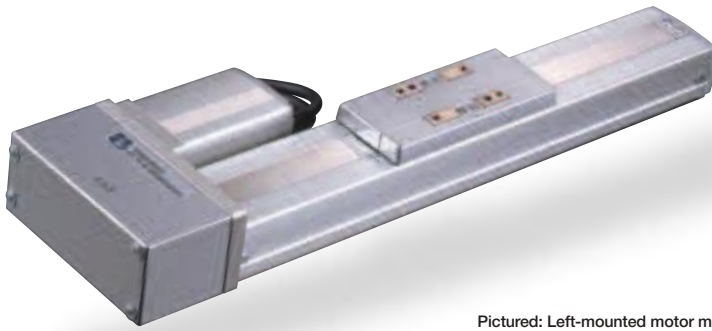

Pictured: Left-mounted motor model (ML).

Technical References A-5

- POINT** Notes on Selection
- When the stroke increases, the maximum speed will drop to prevent the ball screw from reaching the critical rotational speed. Use the actuator specification table below to check the maximum speed at the stroke you desire.
 - Since the RCP2 series use a pulse motor, the load capacity decreases at high speeds. Check in the Speed vs. Load Capacity graph to see if your desired speed and load capacity are supported.
 - The load capacity is based on operation at an acceleration of 0.3G (0.2G for the 4mm-lead model, or when used vertically). These values are the upper limits for the acceleration.

■ Speed vs. Load Capacity
 Due to the characteristics of the pulse motor, the RCP2 series' load capacity decreases at high speeds. In the table below, check if your desired speed and load capacity are supported.

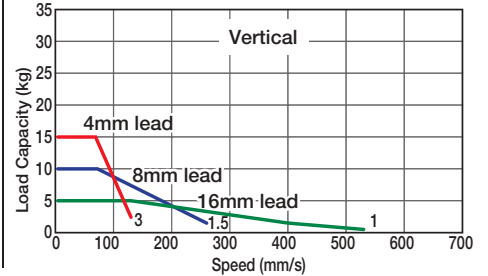
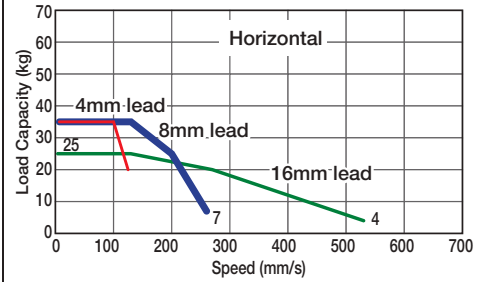

Actuator Specifications

■ Lead and Load Capacity (Note 1) Please note that the maximum load capacity decreases as the speed increases.

Model	Lead (mm)	Max. Load Capacity (Note 1)		Stroke (mm)
		Horizontal (kg)	Vertical (kg)	
RCP2-SA7R-I-56P-16-①-②-③-④	16	~ 25	~ 5	50 ~ 800 (50mm increments)
RCP2-SA7R-I-56P-8-①-②-③-④	8	~ 35	~ 10	
RCP2-SA7R-I-56P-4-①-②-③-④	4	~ 35	~ 15	

Legend ① Stroke ② Compatible controller ③ Cable length ④ Options

■ Stroke and Maximum Speed

Lead	Stroke	50 ~ 700 (50mm increments)	~ 800 (mm)
		16	533 <400>
8		266	240
4		133	120

* The values enclosed in < > apply to vertical setting. (Unit: mm/s)

Cable List

Type	Cable Symbol
Standard	P (1m)
	S (3m)
	M (5m)
Special Lengths	X06 (6m) ~ X10 (10m)
	X11 (11m) ~ X15 (15m)
	X16 (16m) ~ X20 (20m)
Robot Cable	R01 (1m) ~ R03 (3m)
	R04 (4m) ~ R05 (5m)
	R06 (6m) ~ R10 (10m)
	R11 (11m) ~ R15 (15m)
	R16 (16m) ~ R20 (20m)

* See page A-39 for cables for maintenance.

Option List

Name	Option Code	See Page
Brake	B	→ A-25
Reversed-home	NM	→ A-33
Left-Mounted Motor (Standard)	ML	→ A-33
Right-Mounted Motor	MR	→ A-33
Slider Roller	SR	→ A-36

Actuator Specifications

Item	Description
Drive System	Ball screw ø12mm C10 grade
Positioning Repeatability	±0.02mm
Lost Motion	0.1mm or less
Base	Material: Aluminum (white alumite treated)
Allowable Static Moment	Ma: 50.4 N·m Mb: 71.9 N·m Mc: 138.0 N·m
Allowable Dynamic Moment (*)	Ma: 13.9 N·m Mb: 19.9 N·m Mc: 38.3 N·m
Overhang Load Length	Ma direction: 230mm or less; Mb-Mc direction: 230mm or less
Ambient Operating Temp./Humidity	0~40°C, 85% RH or less (Non-condensing)

(*) Based on 5,000km travel life.

Directions of Allowable Load Moments

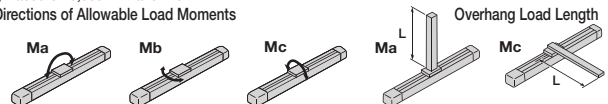

Dimensions

CAD drawings can be downloaded from IAI website. www.robocylinder.de



*For the reversed-home model, the dimensions (distance to home) on the motor-side and that on the opposite side are flipped.

For Special Orders A-9

- The motor-encoder cable is connected here. See page A-39 for details on cables.
- When homing, the slider moves to the ME; therefore, please watch for any interference with the surrounding objects.
ME: Mechanical end
SE: Stroke end
The values enclosed in "() " are reference dimensions.
*The offset reference position for the moment Ma is the same as the SA7 type. (See P32)

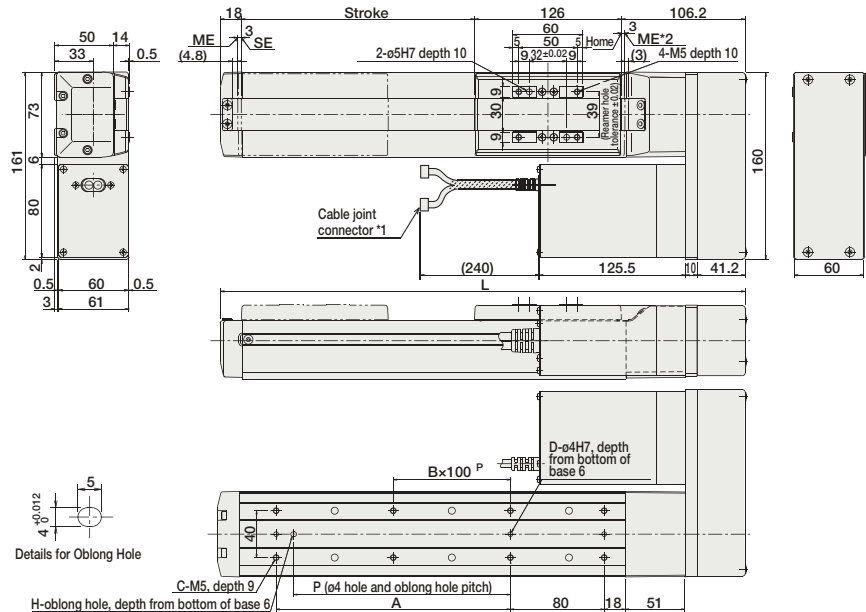

Dimensions of the brake section

* Adding a brake will increase the actuator's overall length by 43mm, and its weight by 0.6kg.

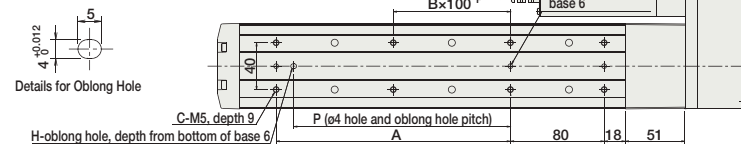
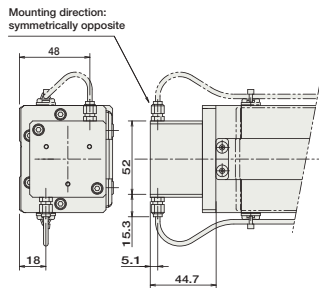

* For brake cable exiting from the side, it can only exit from the motor side.

■ Dimensions/Weight by Stroke

Stroke	50	100	150	200	250	300	350	400	450	500	550	600	650	700	750	800
L	300.2	350.2	400.2	450.2	500.2	550.2	600.2	650.2	700.2	750.2	800.2	850.2	900.2	950.2	1000.2	1050.2
A	0	100	100	200	200	300	300	400	400	500	500	600	600	700	700	800
B	0	0	0	1	1	2	2	3	3	4	4	5	5	6	6	7
C	4	6	6	8	8	10	10	12	12	14	14	16	16	18	18	20
D	2	3	3	3	3	3	3	3	3	3	3	3	3	3	3	3
H	0	1	1	1	1	1	1	1	1	1	1	1	1	1	1	1
P	0	85	85	185	185	285	285	385	385	485	485	585	585	685	685	785
Weight (kg)	4.5	4.7	5.0	5.2	5.4	5.6	5.9	6.1	6.3	6.5	6.8	7.0	7.2	7.4	7.7	7.9

Compatible Controllers

The RCP2 series actuators can operate with the controllers below. Select the controller according to your usage.

Name	External View	Model	Description	Max. Positioning Points	Input Voltage	Power Supply Capacity	See Page
Solenoid Valve Type		PMEC-C-56PI-NP-2-2	Easy-to-use controller, even for beginners	3 points	AC115V AC230V	See P481	→ P477
		PSEP-C-56PI-NP-2-0	Operable with same signal as solenoid valve. Supports both single and double solenoid types. No homing necessary with simple absolute type.				
Splash-Proof Solenoid Valve Type		PSEP-CW-56PI-NP-2-0					
Positioner Type		PCON-C-56PI-NP-2-0	Positioning is possible for up to 512 points	512 points			
Safety-Compliant Positioner Type		PCON-CG-56PI-NP-2-0					
Pulse Train Input Type (Differential Line Driver)		PCON-PL-56PI-NP-2-0	Pulse train input type with differential line driver support	(-)	DC24V	2A max.	→ P525
Pulse Train Input Type (Open Collector)		PCON-PO-56PI-NP-2-0	Pulse train input type with open collector support				
Serial Communication Type		PCON-SE-56PI-N-0-0	Dedicated to serial communication	64 points			
Field Network Type		RPCON-56P	Dedicated to field network	768 points			→ P503
Program Control Type		PSEL-C-1-56PI-NP-2-0	Programmed operation is possible. Can operate up to 2 axes	1500 points			→ P557

* This is for the single-axis PSEL.

- Slider Type
- Mini
- Standard
- Controllers Integrated
- Rod Type
- Mini
- Standard
- Controllers Integrated
- Table/Arm /Flat Type
- Mini
- Standard
- Gripper/ Rotary Type
- Linear Motor Type
- Cleanroom Type
- Splash-Proof
- Controllers
- PMEC /AMEC
- PSEP /ASEP
- ROBO NET
- ERC2
- PCON
- ACON
- SCON
- PSEL
- ASEL
- SSEL
- XSEL
- Pulse Motor
- Servo Motor (24V)
- Servo Motor (230V)
- Linear Motor

- Slider Type
- Mini
- Standard
- Controllers Integrated
- Rod Type
- Mini
- Standard
- Controllers Integrated
- Table/Arm /Flat Type
- Mini
- Standard
- Gripper/ Rotary Type
- Linear Motor Type
- Cleanroom Type
- Splash-Proof
- Controllers
- PMEC /AMEC
- PSEP /ASEP
- ROBO NET
- ERC2
- PCON
- ACON
- SCON
- PSEL
- ASEL
- SSEL
- XSEL
- Pulse Motor
- Servo Motor (24V)
- Servo Motor (230V)
- Linear Motor

RCP2-SS7R RoboCylinder Slider Type 60mm Width Pulse Motor Side-Mounted Motor Steel Base

■ Configuration: **RCP2** - **SS7R** - **I** - **42P** - - - - -

Series Type Encoder Motor Lead Stroke Compatible Controllers Cable Length Option

I: Incremental 42P: Pulse motor 12: 12mm 50: 50mm P1: PCON N: None See Options below
 * The Simple absolute encoder models are labeled as "I". 42 □ size 6: 6mm \ RPCON P: 1m * Be sure to specify which side the motor is to be mounted (ML/MR).
 3: 3mm 600: 600mm (50mm pitch increments) P3: PMEAC S: 3m X □ □ : Custom Length
 R □ □ : Robot cable

* See page Pre-35 for explanation of each code that makes up the configuration name.

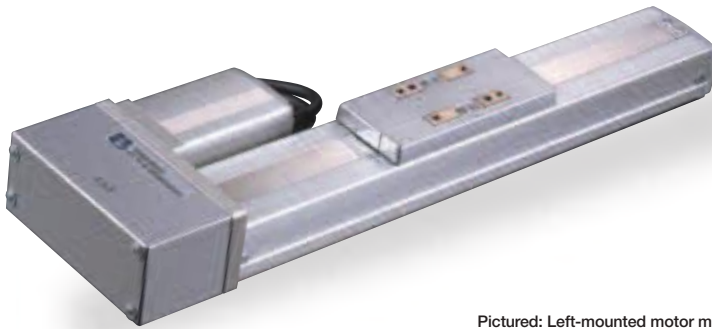

Pictured: Left-mounted motor model (ML).

Technical References A-5

- POINT** Notes on Selection
- When the stroke increases, the maximum speed will drop to prevent the ball screw from reaching the critical rotational speed. Use the actuator specification table below to check the maximum speed at the stroke you desire.
 - Since the RCP2 series use a pulse motor, the load capacity decreases at high speeds. Check in the Speed vs. Load Capacity graph to see if your desired speed and load capacity are supported.
 - The load capacity is based on operation at an acceleration of 0.3G (0.2G for the 3mm-lead model, or when used vertically). These values are the upper limits for the acceleration.

■ Speed vs. Load Capacity
 Due to the characteristics of the pulse motor, the RCP2 series' load capacity decreases at high speeds. In the table below, check if your desired speed and load capacity are supported.

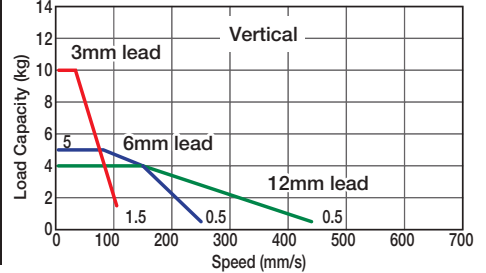
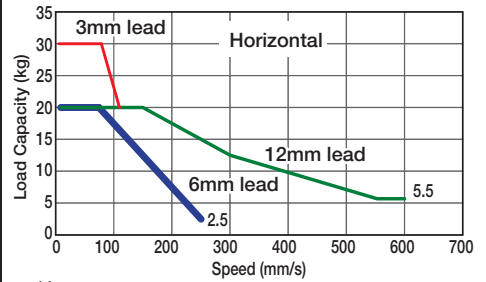

Actuator Specifications

Lead and Load Capacity

(Note 1) Please note that the maximum load capacity decreases as the speed increases.

Model	Lead (mm)	Max. Load Capacity (Note 1)		Stroke (mm)
		Horizontal (kg)	Vertical (kg)	
RCP2-SS7R-I-42P-12-①-②-③-④	12	~ 20	~ 4	50 ~ 600 (50mm increments)
RCP2-SS7R-I-42P-6-①-②-③-④	6	~ 20	~ 5	
RCP2-SS7R-I-42P-3-①-②-③-④	3	~ 30	~ 10	

Legend ① Stroke ② Compatible controller ③ Cable length ④ Options

Stroke and Maximum Speed

Stroke / Lead	50 ~ 500 (50mm increments)	~ 600 (mm)
	12	600 <440>
6	250	230
3	105	105

* The values enclosed in < > apply to vertical setting. (Unit: mm/s)

Cable List

Type	Cable Symbol
Standard	P (1m)
	S (3m)
	M (5m)
Special Lengths	X06 (6m) ~ X10 (10m)
	X11 (11m) ~ X15 (15m)
	X16 (16m) ~ X20 (20m)
Robot Cable	R01 (1m) ~ R03 (3m)
	R04 (4m) ~ R05 (5m)
	R06 (6m) ~ R10 (10m)
	R11 (11m) ~ R15 (15m)
	R16 (16m) ~ R20 (20m)

* See page A-39 for cables for maintenance.

Actuator Specifications

Item	Description
Drive System	Ball screw Ø10mm C10 grade
Positioning Repeatability	±0.02mm
Lost Motion	0.1mm or less
Base	Material: Special alloy steel
Allowable Static Moment	Ma: 79.4 N·m Mb: 79.4 N·m Mc: 172.9 N·m
Allowable Dynamic Moment (*)	Ma: 14.7 N·m Mb: 14.7 N·m Mc: 33.3 N·m
Overhang Load Length	Ma direction: 300mm or less; Mb-Mc direction: 300mm or less
Ambient Operating Temp./Humidity	0~40°C, 85% RH or less (Non-condensing)

(*) Based on 10,000km travel life.

Directions of Allowable Load Moments

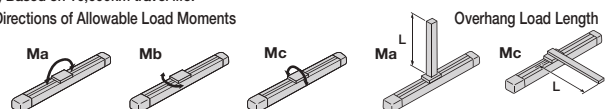

Option List

Name	Option Code	See Page
Brake	B	→ A-25
Reversed-home	NM	→ A-33
Left-Mounted Motor (Standard)	ML	→ A-33
Right-Mounted Motor	MR	→ A-33
Slider Roller	SR	→ A-36

- Slider Type
- Mini
- Standard
- Controllers Integrated
- Rod Type
- Mini
- Standard
- Controllers Integrated
- Table/Arm /Flat Type
- Mini
- Standard
- Gripper/ Rotary Type
- Linear Motor Type
- Cleanroom Type
- Splash Proof
- Controllers
- PMEC /AMEC
- PSEP /ASEP
- ROBO NET
- ERC2
- PCON
- ACON
- SCON
- PSEL
- ASEL
- SSEL
- XSEL
- Pulse Motor
- Servo Motor (24V)
- Servo Motor (230V)
- Linear Motor

Dimensions

CAD drawings can be downloaded from IAI website. www.robocylinder.de

For Special Orders



*For the reversed-home model, the dimensions (distance to home) on the motor-side and that on the opposite side are flipped.

- * The reference surface is the same as the SS7C type. (See P34)
- * The offset reference position for the moment Ma is the same as the SS7C type. (See P34)

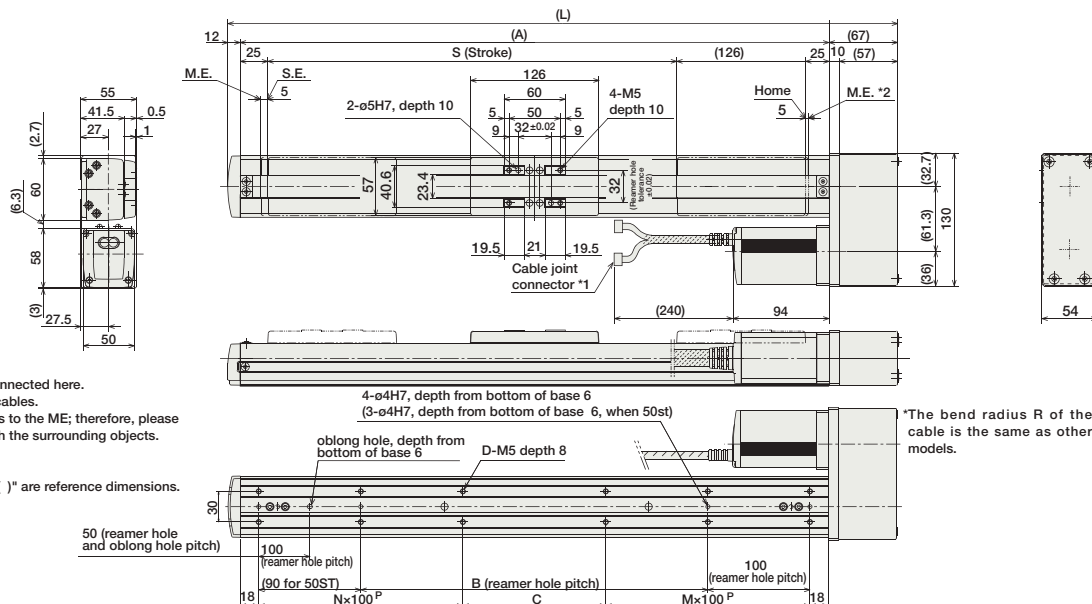

- *1: The motor-encoder cable is connected here. See page A-39 for details on cables.
- *2: When homing, the slider moves to the ME; therefore, please watch for any interference with the surrounding objects.
ME: Mechanical end
SE: Stroke end
The dimensions enclosed in "()" are reference dimensions.

Dimensions of the brake section

* Adding a brake increases the actuator's overall length by 24.5mm and its weight by 0.3kg.

Details for Oblong Hole

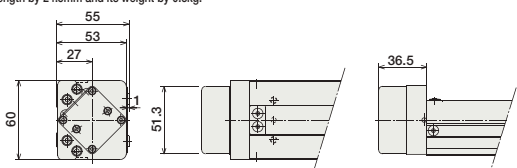

Dimensions/Weight by Stroke

Stroke	50	100	150	200	250	300	350	400	450	500	550	600
L	305	355	405	455	505	555	605	655	705	755	805	855
A	226	276	326	376	426	476	526	576	626	676	726	776
B	0	40	90	140	190	240	290	340	390	440	490	540
C	90	40	90	140	190	40	90	140	190	40	90	140
D	6	8	8	8	8	12	12	12	12	16	16	16
M	1	1	1	1	1	2	2	2	2	3	3	3
N	0	1	1	1	1	2	2	2	2	3	3	3
Weight (kg)	3.8	4.1	4.4	4.7	5.1	5.4	5.8	6.1	6.4	6.7	7.1	7.4

* The brake cable is passed through the actuator body and connected to the motor cable.

Compatible Controllers

The RCP2 series actuators can operate with the controllers below. Select the controller according to your usage.

Name	External View	Model	Description	Max. Positioning Points	Input Voltage	Power Supply Capacity	See Page
Solenoid Valve Type		PMEC-C-42PI-NP-2-2	Easy-to-use controller, even for beginners	3 points	AC115V AC230V	See P481	→ P477
		PSEP-C-42PI-NP-2-0	Operable with same signal as solenoid valve. Supports both single and double solenoid types. No homing necessary with simple absolute type.				
Splash-Proof Solenoid Valve Type		PSEP-CW-42PI-NP-2-0					
Positioner Type		PCON-C-42PI-NP-2-0	Positioning is possible for up to 512 points	512 points			
Safety-Compliant Positioner Type		PCON-CG-42PI-NP-2-0					
Pulse Train Input Type (Differential Line Driver)		PCON-PL-42PI-NP-2-0	Pulse train input type with differential line driver support	(-)	DC24V	2A max.	→ P625
Pulse Train Input Type (Open Collector)		PCON-PO-42PI-NP-2-0	Pulse train input type with open collector support				
Serial Communication Type		PCON-SE-42PI-N-0-0	Dedicated to serial communication	64 points			
Field Network Type		RPCON-42P	Dedicated to field network	768 points			→ P503
Program Control Type		PSEL-C-1-42PI-NP-2-0	Programmed operation is possible Can operate up to 2 axes	1500 points			→ P557

* This is for the single-axis PSEL.

- Slider Type
- Mini
- Standard
- Controllers Integrated
- Rod Type
- Mini
- Standard
- Controllers Integrated
- Table/Arm /Flat Type
- Mini
- Standard
- Gripper/ Rotary Type
- Linear Motor Type
- Cleanroom Type
- Splash-Proof
- Controllers
- PMEC /AMEC
- PSEP /ASEP
- ROBO NET
- ERC2
- PCON
- ACON
- SCON
- PSEL
- ASEL
- SSEL
- XSEL
- Pulse Motor
- Servo Motor (24V)
- Servo Motor (230V)
- Linear Motor

RCP2-SS8R RoboCylinder Slider Type 80mm Width Pulse Motor Side-Mounted Motor Steel Base

■ Configuration: **RCP2** — **SS8R** — **I** — **56P** — — — — —

Series — Type — Encoder — Motor — Lead — Stroke — Compatible Controllers — Cable Length — Option

I: Incremental 56P: Pulse motor 20:20mm 50: 50mm P1:PCON N: None See Options below
 * The Simple absolute encoder models are labeled as "I". 56 size 10:10mm } RPCON P: 1m * Be sure to specify which side the motor is to be mounted (ML/MR).
 5: 5mm 1000:1000mm (50mm pitch increments) P3:PMEC S: 3m X : Custom Length
 PSEP M: 5m R : Robot cable

* See page Pre-35 for explanation of each code that makes up the configuration name.

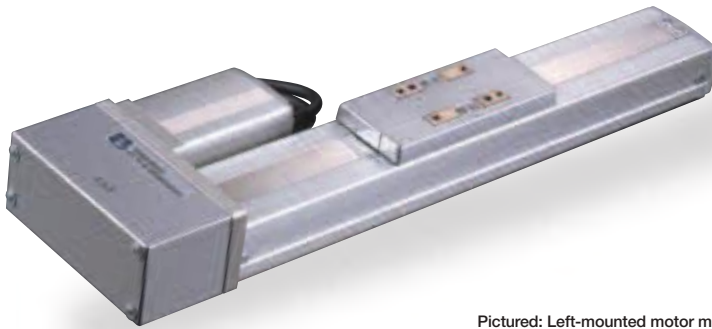

Pictured: Left-mounted motor model (ML).

Technical References A-5

- POINT**
Notes on Selection
- When the stroke increases, the maximum speed will drop to prevent the ball screw from reaching the critical rotational speed. Use the actuator specification table below to check the maximum speed at the stroke you desire.
 - Since the RCP2 series use a pulse motor, the load capacity decreases at high speeds. Check in the Speed vs. Load Capacity graph to see if your desired speed and load capacity are supported.
 - The load capacity is based on operation at an acceleration of 0.3G (0.2G for the 5mm-lead model, or when used vertically).
- These values are the upper limits for the acceleration.

■ Speed vs. Load Capacity
 Due to the characteristics of the pulse motor, the RCP2 series' load capacity decreases at high speeds. In the table below, check if your desired speed and load capacity are supported.

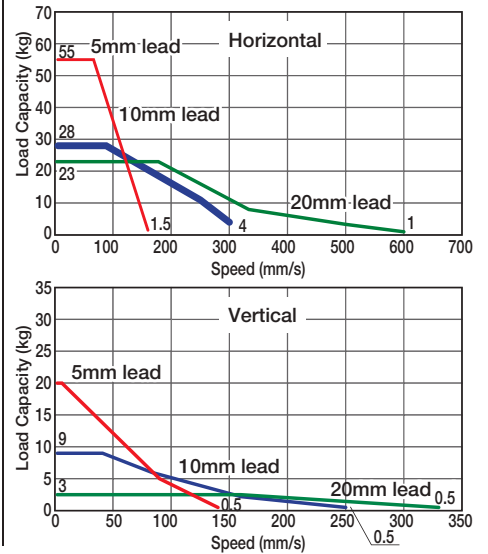

Actuator Specifications

■ Lead and Load Capacity (Note 1) Please note that the maximum load capacity decreases as the speed increases.

Model	Lead (mm)	Max. Load Capacity (Note 1)		Stroke (mm)
		Horizontal (kg)	Vertical (kg)	
RCP2-SS8R-I-56P-20-①-②-③-④	20	~ 23	~ 3	50 ~ 1000 (50mm increments)
RCP2-SS8R-I-56P-10-①-②-③-④	10	~ 28	~ 9	
RCP2-SS8R-I-56P-5-①-②-③-④	5	~ 55	~ 20	

Legend ① Stroke ② Compatible controller ③ Cable length ④ Options

■ Stroke and Maximum Speed

Stroke / Lead	50 ~ 800 (50mm increments)	~ 900 (mm)	~ 1000 (mm)
	20	600 <333>	600 <333>
10	300 <250>	300 <250>	255 <250>
5	160 <140>	155 <140>	125 <140>

* The values enclosed in < > apply to vertical setting. (Unit: mm/s)

Cable List

Type	Cable Symbol
Standard	P (1m)
	S (3m)
	M (5m)
Special Lengths	X06 (6m) ~ X10 (10m)
	X11 (11m) ~ X15 (15m)
	X16 (16m) ~ X20 (20m)
Robot Cable	R01 (1m) ~ R03 (3m)
	R04 (4m) ~ R05 (5m)
	R06 (6m) ~ R10 (10m)
	R11 (11m) ~ R15 (15m)
	R16 (16m) ~ R20 (20m)

* See page A-39 for cables for maintenance.

Actuator Specifications

Item	Description
Drive System	Ball screw ø16mm C10 grade
Positioning Repeatability	±0.02mm
Lost Motion	0.1 mm or less
Base	Material: Special alloy steel
Allowable Static Moment	Ma: 198.9 N·m Mb: 198.9 N·m Mc: 416.7 N·m
Allowable Dynamic Moment (*)	Ma: 36.3 N·m Mb: 36.3 N·m Mc: 77.4 N·m
Overhang Load Length	Ma direction: 450mm or less; Mb-Mc direction: 450mm or less
Ambient Operating Temp./Humidity	0~40°C, 85% RH or less (Non-condensing)

(*) Based on 10,000km travel life.

Directions of Allowable Load Moments

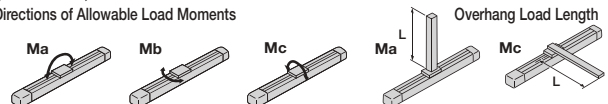

Option List

Name	Option Code	See Page
Brake	B	→ A-25
Reversed-home	NM	→ A-33
Left-Mounted Motor (Standard)	ML	→ A-33
Right-Mounted Motor	MR	→ A-33
Slider Roller	SR	→ A-36

Dimensions

CAD drawings can be downloaded from IAI website. www.robocylinder.de

For Special Orders A-9



*For the reversed-home model, the dimensions (distance to home) on the motor-side and that on the opposite side are flipped.

- * The reference surface is the same as the SS8C type. (See P36)
- * The offset reference position for the moment Ma is the same as the SS8C type. (See P36)

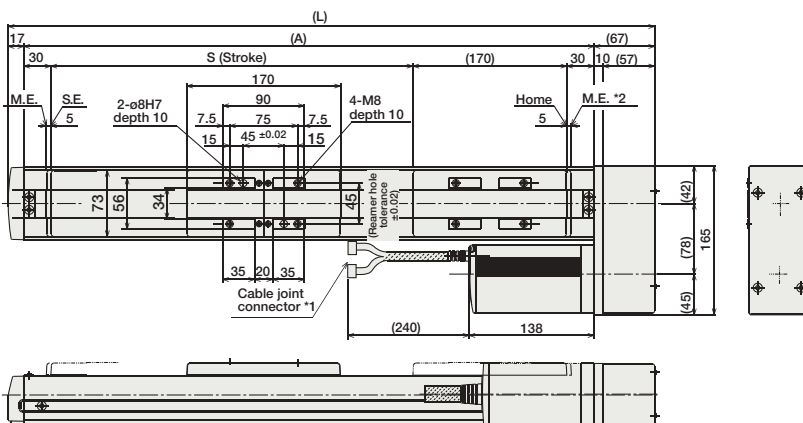
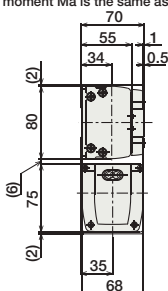

- *1: The motor-encoder cable is connected here. See page A-39 for details on cables.
 - *2: When homing, the slider moves to the ME; therefore, please watch for any interference with the surrounding objects.
- ME: Mechanical end
SE: Stroke end
The dimensions enclosed in "()" are reference dimensions.

Dimensions of the brake section

* Adding a brake will increase the actuator's length by 26mm and its weight by 0.5kg.

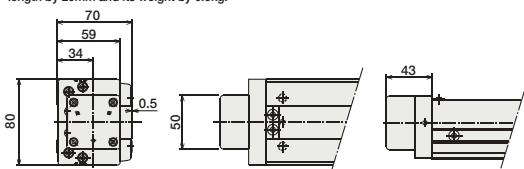

* The brake cable is passed through the actuator body and connected to the motor cable.

Dimensions/Weight by Stroke

Stroke	50	100	150	200	250	300	350	400	450	500	550	600	650	700	750	800	850	900	950	1000
L	364	414	464	514	564	614	664	714	764	814	864	914	964	1014	1064	1114	1164	1214	1264	1314
A	280	330	380	430	480	530	580	630	680	730	780	830	880	930	980	1030	1080	1130	1180	1230
B	50	100	150	200	250	300	350	400	450	500	550	600	650	700	750	800	850	900	950	1000
D	8	8	8	10	12	12	12	14	16	16	16	18	20	20	20	22	24	24	24	26
F	50	100	150	0	50	100	150	0	50	100	150	0	50	100	150	0	50	100	150	0
N	1	1	1	2	2	2	3	3	3	3	3	4	4	4	4	5	5	5	5	6
Weight (kg)	7.4	7.9	8.5	9.0	9.5	10	10.5	11.1	11.6	12.1	12.7	13.2	13.7	14.3	14.8	15.3	15.8	16.4	16.9	17.4

Compatible Controllers

The RCP2 series actuators can operate with the controllers below. Select the controller according to your usage.

Name	External View	Model	Description	Max. Positioning Points	Input Voltage	Power Supply Capacity	See Page
Solenoid Valve Type		PMEC-C-56PI-NP-2-2	Easy-to-use controller, even for beginners	3 points	AC115V AC230V	See P481	→ P477
		PSEP-C-56PI-NP-2-0	Operable with same signal as solenoid valve. Supports both single and double solenoid types. No homing necessary with simple absolute type.				→ P487
Splash-Proof Solenoid Valve Type		PSEP-CW-56PI-NP-2-0					
Positioner Type		PCON-C-56PI-NP-2-0	Positioning is possible for up to 512 points	512 points			
Safety-Compliant Positioner Type		PCON-CG-56PI-NP-2-0					
Pulse Train Input Type (Differential Line Driver)		PCON-PL-56PI-NP-2-0	Pulse train input type with differential line driver support	(-)	DC24V	2A max.	→ P525
Pulse Train Input Type (Open Collector)		PCON-PO-56PI-NP-2-0	Pulse train input type with open collector support				
Serial Communication Type		PCON-SE-56PI-N-0-0	Dedicated to serial communication	64 points			
Field Network Type		RPCON-56P	Dedicated to field network	768 points			→ P503
Program Control Type		PSEL-C-1-56PI-NP-2-0	Programmed operation is possible. Can operate up to 2 axes	1500 points			→ P557

* This is for the single-axis PSEL.

- Slider Type
- Mini
- Standard
- Controllers Integrated
- Rod Type
- Mini
- Standard
- Controllers Integrated
- Table/Arm /Flat Type
- Mini
- Standard
- Gripper/ Rotary Type
- Linear Motor Type
- Cleanroom Type
- Splash Proof
- Controllers
- PMEC /AMEC
- PSEP /ASEP
- ROBO NET
- ERC2
- PCON
- ACON
- SCON
- PSEL
- ASEL
- SSEL
- XSEL
- Pulse Motor
- Servo Motor (24V)
- Servo Motor (230V)
- Linear Motor

- Slider Type
- Mini
- Standard
- Controllers Integrated
- Rod Type
- Mini
- Standard
- Controllers Integrated
- Table/Arm /Flat Type
- Mini
- Standard
- Gripper/ Rotary Type
- Linear Motor Type
- Cleanroom Type
- Splash-Proof
- Controllers
- PMEC /AMEC
- PSEP /ASEP
- ROBO NET
- ERC2
- PCON
- ACON
- SCON
- PSEL
- ASEL
- SSEL
- XSEL
- Pulse Motor
- Servo Motor (24V)
- Servo Motor (230V)
- Linear Motor

RCP2-HS8R RoboCylinder High-Speed Slider Type 80mm Width Pulse Motor Side-Mounted Motor Steel Base

■ Configuration: **RCP2** — **HS8R** — **I** — **86P** — — — **P2** — —

Series — Type — Encoder — Motor — Lead — Stroke — Compatible Controllers — Cable Length — Option

I: Incremental 86P: Pulse motor 30:30mm 50: 50mm P2:PCON-CF N : None BE : Brake (Cable exiting end)
 * The Simple absolute encoder models are labeled as "I". 56 □ high output 1000:1000mm (50mm pitch increments) M : 5m BL : Brake (Cable exiting left)
 X □ □ : Custom Length¹⁾ SR : Slider Roller
 R □ □ : Robot cable

* See page Pre-35 for explanation of each code that makes up the configuration name.

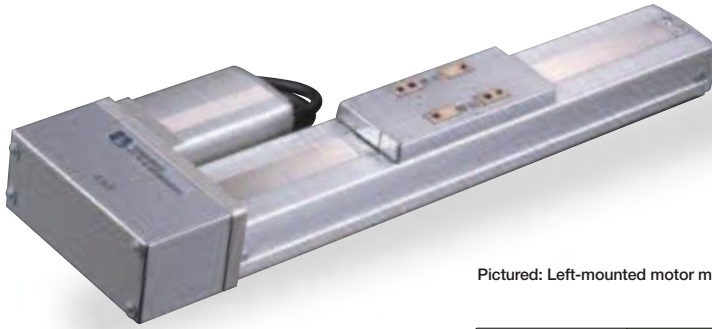

Pictured: Left-mounted motor model (ML).

Technical References A-5

- POINT** Notes on Selection
- (1) Due to the large lead of the ball screw in high-speed actuators, operating at low speeds may cause vibration and/or noise. Therefore, use the actuator at speeds over 100mm/s.
 - (2) When the stroke increases, the maximum speed will drop to prevent the ball screw from reaching the critical rotational speed. Use the actuator specification table below to check the maximum speed at the stroke you desire.
 - (3) Since the RCP2 series use a pulse motor, the load capacity decreases at high speeds. Check in the Speed vs. Load Capacity graph to see if your desired speed and load capacity are supported.
 - (4) The load capacity is based on operation at an acceleration of 0.3G (0.2G when used vertically). The upper limit for the acceleration is 0.5G for horizontal use and 0.2G for vertical use.

■ Speed vs. Load Capacity
 Due to the characteristics of the pulse motor, the RCP2 series' load capacity decreases at high speeds. In the table below, check if your desired speed and load capacity are supported.

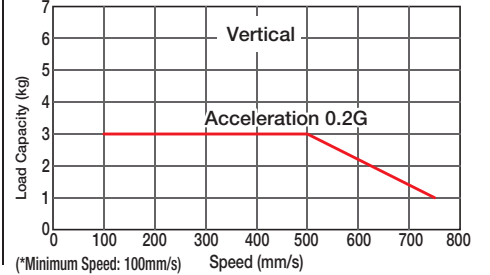
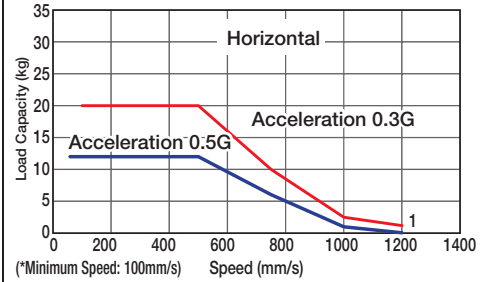

Actuator Specifications

Lead and Load Capacity

(Note 1) Please note that the maximum load capacity decreases as the speed increases.

Model	Lead (mm)	Max. Load Capacity (Note 1)		Stroke (mm)
		Horizontal (kg)	Vertical (kg)	
RCP2-HS8R-I-86P-30-①-P2-②-③	30	~ 20	~ 3	50 ~ 1000 (50mm increments)

Legend ① Stroke ② Cable length ③ Options

Stroke and Maximum Speed

Stroke / Lead	50 ~ 800 (50mm increments)	~ 900 (mm)	~ 1000 (mm)
30	1200 <750>	1000 <750>	800 <750>

* The values enclosed in < > apply to vertical setting. (Unit: mm/s)

Cable List

Type	Cable Symbol
Standard	P (1m)
	S (3m)
	M (5m)
Special Lengths	X06 (6m) ~ X10 (10m)
	X11 (11m) ~ X15 (15m)
	X16 (16m) ~ X20 (20m)
	R01 (1m) ~ R03 (3m)
Robot Cable	R04 (4m) ~ R05 (5m)
	R06 (6m) ~ R10 (10m)
	R11 (11m) ~ R15 (15m)
	R16 (16m) ~ R20 (20m)

* See page A-39 for cables for maintenance.

Option List

Name	Option Code	See Page
Brake	B	→ A-25
Reversed-home	NM	→ A-33
Left-Mounted Motor (Standard)	ML	→ A-33
Right-Mounted Motor	MR	→ A-33
Slider Roller	SR	→ A-36

Actuator Specifications

Item	Description
Drive System	Ball screw ø16mm C10 grade
Positioning Repeatability	±0.02mm
Lost Motion	0.1 mm or less
Base	Material: Special alloy steel
Allowable Static Moment	Ma: 198.9 N·m Mb: 198.9 N·m Mc: 416.7 N·m
Allowable Dynamic Moment (*)	Ma: 36.3 N·m Mb: 36.3 N·m Mc: 77.4 N·m
Overhang Load Length	Ma direction: 450mm or less; Mb-Mc direction: 450mm or less
Ambient Operating Temp./Humidity	0~40°C, 85% RH or less (Non-condensing)

(*) Based on 10,000km travel life.

Directions of Allowable Load Moments

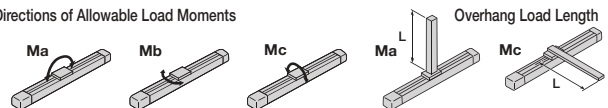

Dimensions

CAD drawings can be downloaded from IAI website. www.robocylinder.de

For Special Orders A-9



*For the reversed-home model, the dimensions (distance to home) on the motor-side and that on the opposite side are flipped.

- * The reference surface is the same as the HS8C type. (See P38)
- * The offset reference position for the moment Ma is the same as the HS8C type. (See P38)

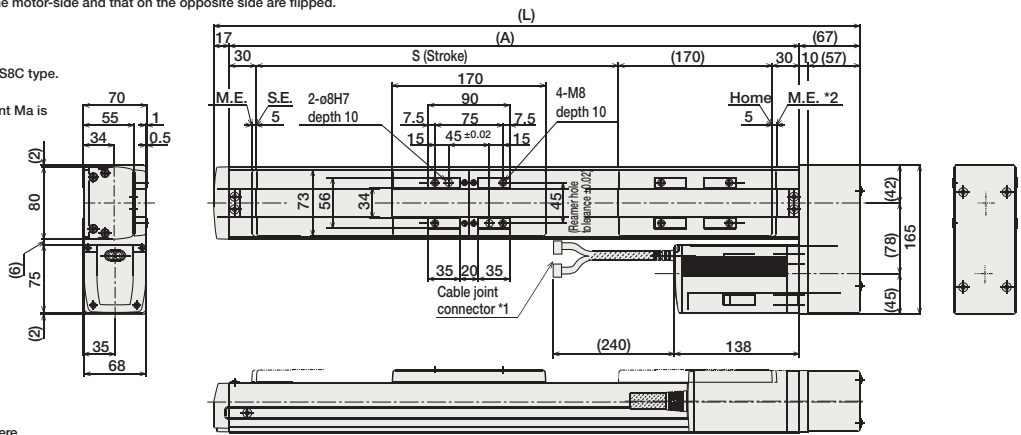

- *1: The motor-encoder cable is connected here. See page A-39 for details on cables.
- *2 When homing, the slider moves to the ME; therefore, please watch for any interference with the surrounding objects.
ME: Mechanical end
SE: Stroke end
The dimensions enclosed in () are reference dimensions.

Dimensions of the brake section

- * Adding a brake will increase the actuator's length by 26mm and its weight by 0.5kg.

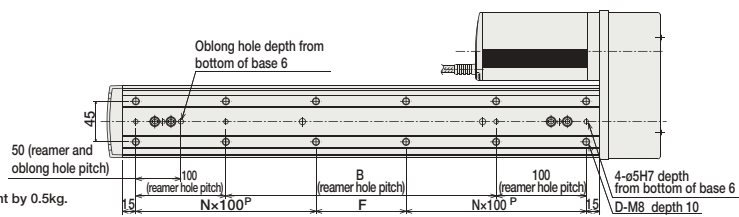
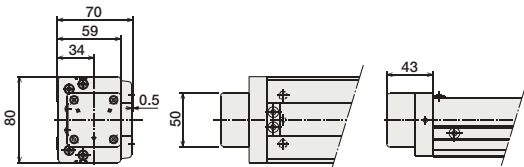

- * The brake cable is passed through the actuator body and connected to the motor cable.

Dimensions/Weight by Stroke

Stroke	50	100	150	200	250	300	350	400	450	500	550	600	650	700	750	800	850	900	950	1000
L	364	414	464	514	564	614	664	714	764	814	864	914	964	1014	1064	1114	1164	1214	1264	1314
A	280	330	380	430	480	530	580	630	680	730	780	830	880	930	980	1030	1080	1130	1180	1230
B	50	100	150	200	250	300	350	400	450	500	550	600	650	700	750	800	850	900	950	1000
D	8	8	8	10	12	12	12	14	16	16	16	18	20	20	20	22	24	24	24	26
F	50	100	150	0	50	100	150	0	50	100	150	0	50	100	150	0	50	100	150	0
N	1	1	1	2	2	2	3	3	3	3	4	4	4	4	5	5	5	5	5	6
Weight (kg)	7.4	7.9	8.5	9.0	9.5	10	10.5	11.1	11.6	12.1	12.7	13.2	13.7	14.3	14.8	15.3	15.8	16.4	16.9	17.4

Compatible Controllers

The controller for the RCP2-HS8R type is a dedicated controller.

Name	External View	Model	Description	Max. Positioning Points	Input Voltage	Power Supply Capacity	See Page
Positioner Type		PCON-CF-86PI-NP-2-0	Positioning is possible for up to 512 points	512 points	DC24V	6A max.	→ P525

- Note:
- Please note that the encoder cable is a dedicated CF-type cable that is different from the PCON-C/CG/CY/PL/PO/SE controllers.
 - Note that a simple absolute unit cannot be used.

- Slider Type
- Mini
- Standard
- Controllers Integrated
- Rod Type
- Mini
- Standard
- Controllers Integrated
- Table/Arm /Flat Type
- Mini
- Standard
- Gripper/ Rotary Type
- Linear Motor Type
- Cleanroom Type
- Splash Proof
- Controllers
- PMEC /AMEC
- PSEP /ASEP
- ROBO NET
- ERC2
- PCON
- ACON
- SCON
- PSEL
- ASEL
- SSEL
- XSEL
- Pulse Motor
- Servo Motor (24V)
- Servo Motor (230V)
- Linear Motor

- Slider Type
- Mini
- Standard
- Controllers Integrated
- Rod Type
- Mini
- Standard
- Controllers Integrated
- Table/Arm /Flat Type
- Mini
- Standard
- Gripper/ Rotary Type
- Linear Motor Type
- Cleanroom Type
- Splash-Proof
- Controllers
- PMEC /AMEC
- PSEP /ASEP
- ROBO NET
- ERC2
- PCON
- ACON
- SCON
- PSEL
- ASEL
- SSEL
- XSEL
- Pulse Motor
- Servo Motor (24V)
- Servo Motor (230V)
- Linear Motor

RCP2-BA6/BA6U

RoboCylinder Belt Type 58mm Width Pulse Motor
Top-Mounted Motor / Bottom-Mounted Motor

■ Configuration: **RCP2** - - **I** - **42P** - **54** - - - -

Series Type Encoder Motor Lead Stroke Compatible Controllers Cable Length Option

BA6 :Belt type Top-mounted motor
BA6U :Belt type Bottom-mounted motor

I: Incremental * The Simple absolute encoder models are labeled as "I".

42P: Pulse motor 42 □ size

54:54mm equivalent

500: 500mm
1000:1000mm (50mm pitch increments)

P1: PCON
RPCON
PSEL
P3: PMEC
PSEP

N : None
P : 1m
S : 3m
M : 5m
X □ : Custom Length
R □ : Robot cable

NM : Reversed-home

* See page Pre-35 for explanation of each code that makes up the configuration name.



Technical References A-5

- POINT** Notes on Selection
- (1) Operating the belt type actuator at low speeds may cause vibration and/or resonance. Therefore, please set the speed at 100mm/s or faster.
 - (2) Since the RCP2 series use a pulse motor, the load capacity decreases at high speeds. Check in the Speed vs. Load Capacity graph to see if your desired speed and load capacity are supported.
 - (3) The load capacity is based on operation at an acceleration of 0.5G. 0.5G is the upper limit for the acceleration.

■ Speed vs. Load Capacity
Due to the characteristics of the pulse motor, the RCP2 series' load capacity decreases at high speeds. In the table below, check if your desired speed and load capacity are supported.

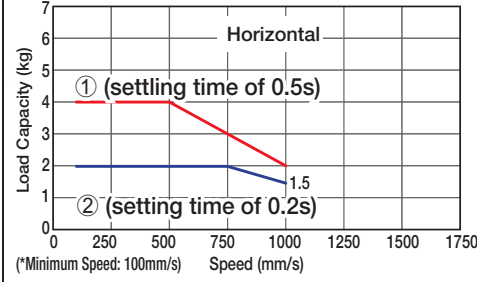

Note:
Graph ① is for standard specifications, with settling time of 0.5s for calculating the positioning time.
Graph ② reflects some changes in the controller settings. The load capacity is lower, however the settling time is decreased to 0.2s.
If the load capacity is lower than graph ②, and you want to shorten the positioning time, change the controller settings. (See the manual for details.)
(Vertical operation is not possible.)

Actuator Specifications					
■ Lead and Load Capacity			■ Stroke and Maximum Speed		
(Note 1) Please note that the maximum load capacity decreases as the speed increases.					
Model	Motor Mounting Direction	Lead (mm)	Max. Load Capacity (Note 1)		Stroke (mm)
			Horizontal (kg)	Vertical (kg)	
RCP2-BA6-I-42P-54-①-②-③-④	Top	54 equivalent	~ 4	Not Allowed	500 ~ 1000 (50mm increments)
RCP2-BA6U-I-42P-54-①-②-③-④	Bottom				54 equivalent

Legend ① Stroke ② Compatible controller ③ Cable length ④ Options

(Unit: mm/s)

Type	Cable Symbol
Standard	P (1m)
	S (3m)
	M (5m)
Special Lengths	X06 (6m) ~ X10 (10m)
	X11 (11m) ~ X15 (15m)
	X16 (16m) ~ X20 (20m)
	R01 (1m) ~ R03 (3m)
Robot Cable	R04 (4m) ~ R05 (5m)
	R06 (6m) ~ R10 (10m)
	R11 (11m) ~ R15 (15m)
	R16 (16m) ~ R20 (20m)

* See page A-39 for cables for maintenance.

Item	Description
Drive System	Timing Belt
Positioning Repeatability	±0.1mm
Lost Motion	0.1 mm or less
Allowable Dynamic Moment (*)	Ma: 8.9 N·m Mb: 12.7 N·m Mc: 18.6 N·m
Overhang Load Length	Ma direction: 150mm or less; Mb-Mc direction: 150mm or less
Ambient Operating Temp./Humidity	0~40°C, 85% RH or less (Non-condensing)

(*) Based on 5,000km travel life.

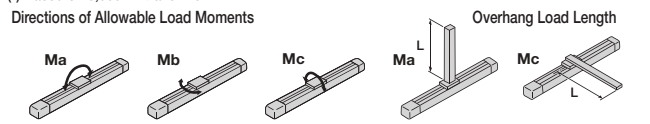

Option List			
Name	Option Code	See Page	
Reversed-home	NM	→ A-33	

Dimensions

CAD drawings can be downloaded from IAI website. www.robocylinder.de



- *1 The motor-encoder cable is connected here. See page A-39 for details on cables.
- *2 When homing, the slider moves to the ME; therefore, please watch for any interference with the surrounding objects.
ME: Mechanical end
SE: Stroke end

For Special Orders A-9

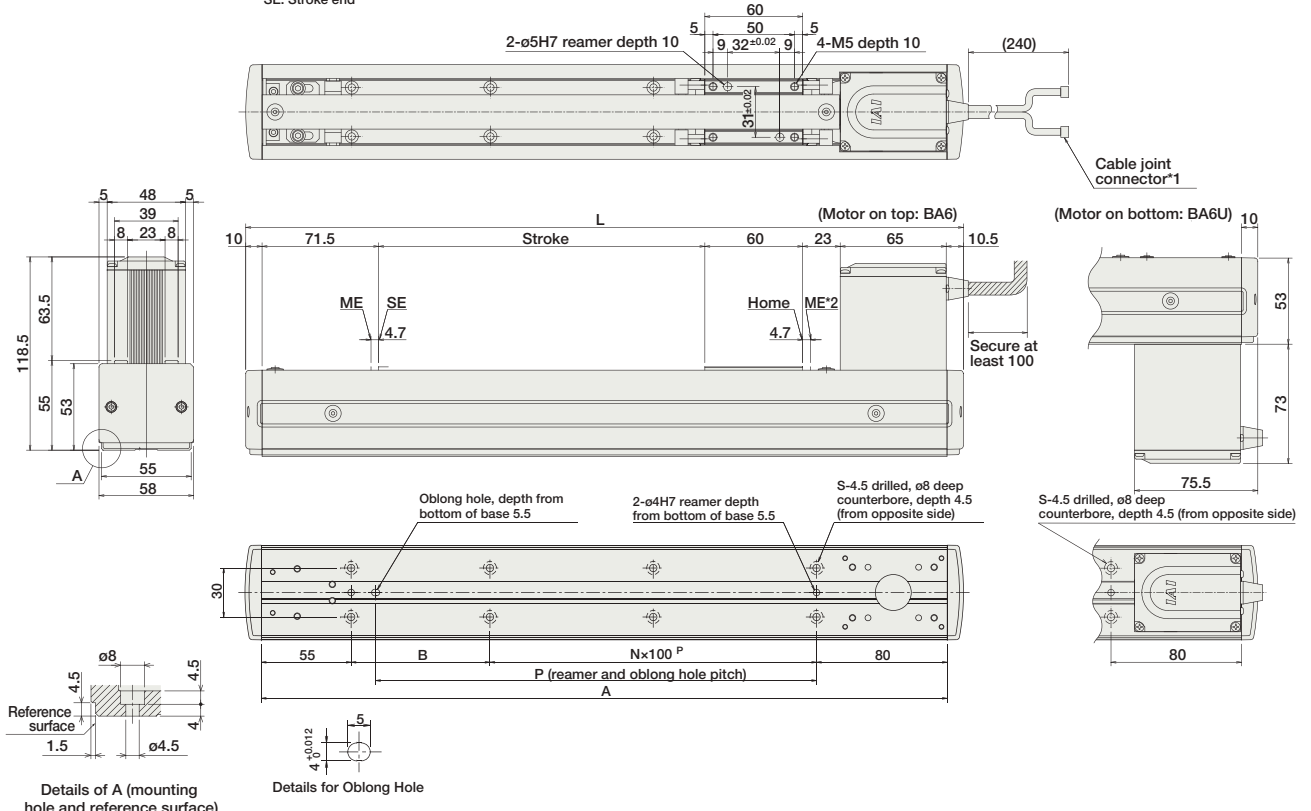

■ Dimensions/Weight by Stroke

Stroke	500	550	600	650	700	750	800	850	900	950	1000
L	740	790	840	890	940	990	1040	1090	1140	1190	1240
A	720	770	820	870	920	970	1020	1070	1120	1170	1220
B	85	35	85	35	85	35	85	35	85	35	85
N	5	6	6	7	7	8	8	9	9	10	10
P	570	620	670	720	770	820	870	920	970	1020	1070
S	14	16	16	18	18	20	20	22	22	24	24
Weight (kg)	2.8	2.9	3.0	3.2	3.3	3.4	3.5	3.7	3.8	3.9	4.1

Compatible Controllers

The RCP2 series actuators can operate with the controllers below. Select the controller according to your usage.

Name	External View	Model	Description	Max. Positioning Points	Input Voltage	Power Supply Capacity	See Page
Solenoid Valve Type		PMEC-C-42PI-NP-2-2	Easy-to-use controller, even for beginners	3 points	AC115V AC230V	See P481	→ P477
		PSEP-C-42PI-NP-2-0	Operable with same signal as solenoid valve. Supports both single and double solenoid types. No homing necessary with simple absolute type.				→ P487
Splash-Proof Solenoid Valve Type		PSEP-CW-42PI-NP-2-0					
Positioner Type		PCON-C-42PI-NP-2-0	Positioning is possible for up to 512 points	512 points			
Safety-Compliant Positioner Type		PCON-CG-42PI-NP-2-0					
Pulse Train Input Type (Differential Line Driver)		PCON-PL-42PI-NP-2-0	Pulse train input type with differential line driver support	(-)	DC24V	2A max.	→ P525
Pulse Train Input Type (Open Collector)		PCON-PO-42PI-NP-2-0	Pulse train input type with open collector support				
Serial Communication Type		PCON-SE-42PI-N-0-0	Dedicated to serial communication	64 points			
Field Network Type		RPCON-42P	Dedicated to field network	768 points			→ P503
Program Control Type		PSEL-C-1-42PI-NP-2-0	Programmed operation is possible. Can operate up to 2 axes	1500 points			→ P557

* This is for the single-axis PSEL.

- Slider Type
- Mini
- Standard
- Controllers Integrated
- Rod Type
- Mini
- Standard
- Controllers Integrated
- Table/Arm /Flat Type
- Mini
- Standard
- Gripper/ Rotary Type
- Linear Motor Type
- Cleanroom Type
- Splash-Proof
- Controllers
- PMEC /AMEC
- PSEP /ASEP
- ROBO NET
- ERC2
- PCON
- ACON
- SCON
- PSEL
- ASEL
- SSEL
- XSEL
- Pulse Motor
- Servo Motor (24V)
- Servo Motor (230V)
- Linear Motor

- Slider Type
- Mini
- Standard
- Controllers Integrated
- Rod Type
- Mini
- Standard
- Controllers Integrated
- Table/Arm /Flat Type
- Mini
- Standard
- Gripper/ Rotary Type
- Linear Motor Type
- Cleanroom Type
- Splash-Proof
- Controllers
- PMEC /AMEC
- PSEP /ASEP
- ROBO NET
- ERC2
- PCON
- ACON
- SCON
- PSEL
- ASEL
- SSEL
- XSEL
- Pulse Motor
- Servo Motor (24V)
- Servo Motor (230V)
- Linear Motor

RCP2-BA7/BA7U

RoboCylinder Belt Type 68mm Width Pulse Motor
Top-Mounted Motor / Bottom-Mounted Motor

■ Configuration: **RCP2** - - **I** - **42P** - **54** - - - -

Series - Type - Encoder - Motor - Lead - Stroke - Compatible Controllers - Cable Length - Option

BA7 : Belt type Top-mounted motor
BA7U: Belt type Bottom-mounted motor

I: Incremental * The Simple absolute encoder models are labeled as "I".

42P: Pulse motor 42 □ size

54:54mm

600: 600mm }
1200:1200mm (50mm pitch increments)

P1: PCON
RPCON
PSEL
P3: PMEC
PSEP

N : None
P : 1m
S : 3m
M : 5m
X □ □ : Custom Length
R □ □ : Robot cable

NM: Reversed-home

* See page Pre-35 for explanation of each code that makes up the configuration name.



Technical References A-5

- POINT**
Notes on Selection
- Operating the belt type actuator at low speeds may cause vibration and/or resonance. Therefore, please set the speed at 100mm/s or faster.
 - Since the RCP2 series use a pulse motor, the load capacity decreases at high speeds. Check in the Speed vs. Load Capacity graph to see if your desired speed and load capacity are supported.
 - The load capacity is based on operation at an acceleration of 0.5G. 0.5G is the upper limit for the acceleration.

■ Speed vs. Load Capacity
Due to the characteristics of the pulse motor, the RCP2 series' load capacity decreases at high speeds. In the table below, check if your desired speed and load capacity are supported.

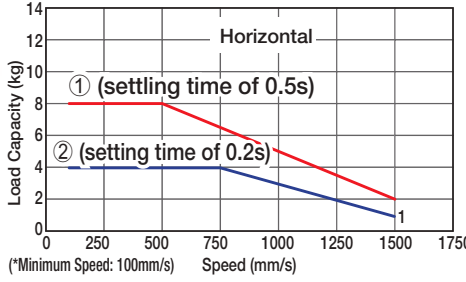

Note:
Graph ① is for standard specifications, with settling time of 0.5s for calculating the positioning time.
Graph ② reflects some changes in the controller settings. The load capacity is lower, however the settling time is decreased to 0.2s.
If the load capacity is lower than graph ②, and you want to shorten the positioning time, change the controller settings. (See the manual for details.)
(Vertical operation is not possible.)

Actuator Specifications					
■ Lead and Load Capacity			■ Stroke and Maximum Speed		
Model	Motor Mounting Direction	Lead (mm)	Max. Load Capacity (Note 1)		Stroke (mm)
			Horizontal (kg)	Vertical (kg)	
RCP2-BA7-I-42P-54-①-②-③-④	Top	54 equivalent	~ 8	Not Allowed	600 ~ 1200 (50mm increments)
RCP2-BA7U-I-42P-54-①-②-③-④	Bottom				
			Stroke	600 ~ 1200 (50mm increments)	
			Lead	54 equivalent	1500

Legend ① Stroke ② Compatible controller ③ Cable length ④ Options (Unit: mm/s)

Type	Cable Symbol
Standard	P (1m)
	S (3m)
	M (5m)
Special Lengths	X06 (6m) ~ X10 (10m)
	X11 (11m) ~ X15 (15m)
	X16 (16m) ~ X20 (20m)
	R01 (1m) ~ R03 (3m)
Robot Cable	R04 (4m) ~ R05 (5m)
	R06 (6m) ~ R10 (10m)
	R11 (11m) ~ R15 (15m)
	R16 (16m) ~ R20 (20m)

* See page A-39 for cables for maintenance.

Item	Description
Drive System	Timing Belt
Positioning Repeatability	±0.1mm
Lost Motion	0.1mm or less
Allowable Dynamic Moment (*)	Ma: 13.8 N·m Mb: 19.7 N·m Mc: 29.0 N·m
Overhang Load Length	Ma direction: 150mm or less; Mb-Mc direction: 150mm or less
Ambient Operating Temp./Humidity	0~40°C, 85% RH or less (Non-condensing)

(*) Based on 5,000km travel life.

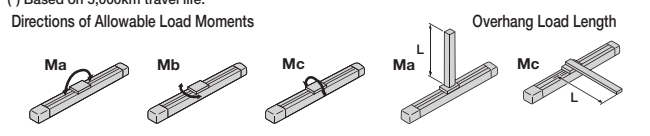

Name	Option Code	See Page
Reversed-home	NM	→ A-33

Dimensions

CAD drawings can be downloaded from IAI website. www.robocylinder.de



*1 The motor-encoder cable is connected here. See page A-39 for details on cables.
 *2 When homing, the slider moves to the ME; therefore, please watch for any interference with the surrounding objects.
 ME: Mechanical end
 SE: Stroke end

For Special Orders A-9

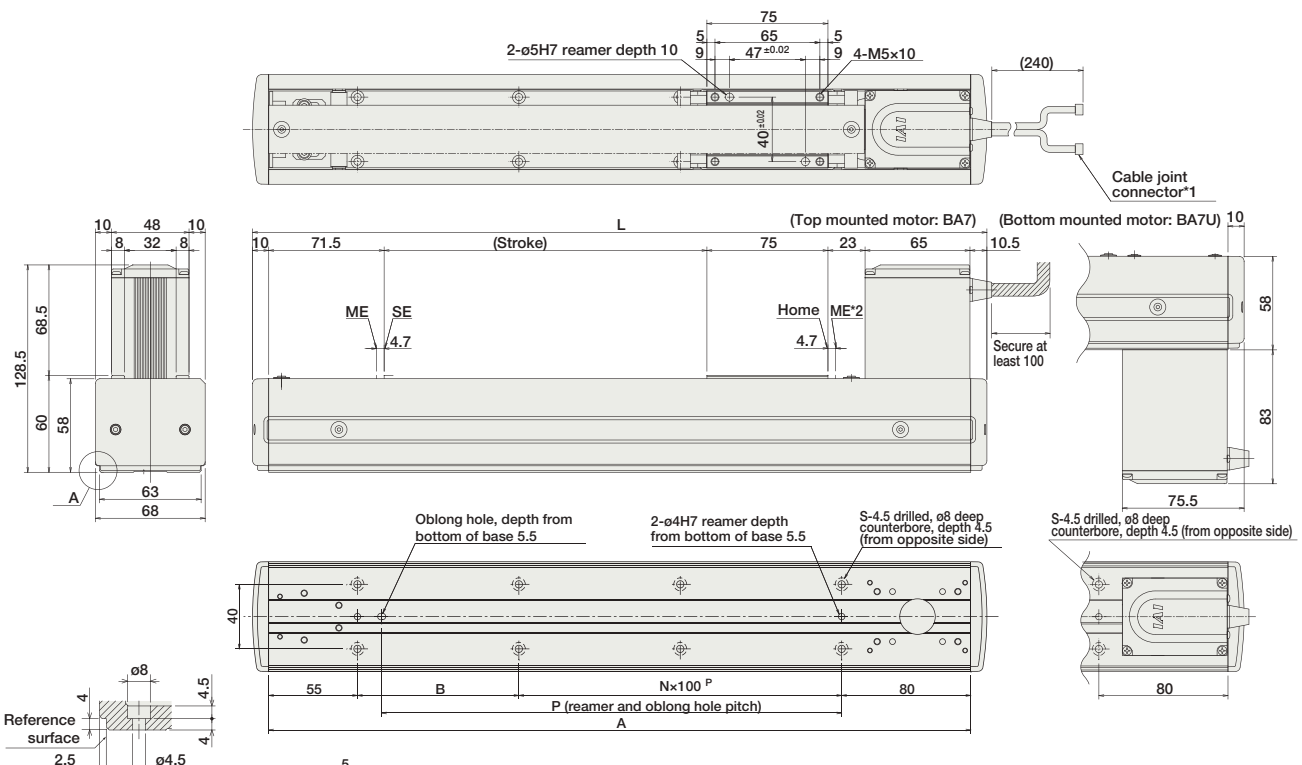

■ Dimensions/Weight by Stroke

Stroke	600	650	700	750	800	850	900	950	1000	1050	1100	1150	1200
L	855	905	955	1005	1055	1105	1155	1205	1255	1305	1355	1405	1455
A	835	885	935	985	1035	1085	1135	1185	1235	1285	1335	1385	1435
B	100	50	100	50	100	50	100	50	100	50	100	50	100
N	6	7	7	8	8	9	9	10	10	11	11	12	12
P	685	735	785	835	885	935	985	1035	1085	1135	1185	1235	1285
S	16	18	18	20	20	22	22	24	24	26	26	28	28
Weight (kg)	3.6	3.7	3.9	4.0	4.2	4.3	4.4	4.6	4.7	4.9	5.0	5.2	5.3

Compatible Controllers

The RCP2 series actuators can operate with the controllers below. Select the controller according to your usage.

Name	External View	Model	Description	Max. Positioning Points	Input Voltage	Power Supply Capacity	See Page
Solenoid Valve Type		PMEC-C-42PI-NP-2-2	Easy-to-use controller, even for beginners	3 points	AC115V AC230V	See P481	→ P477
		PSEP-C-42PI-NP-2-0	Operable with same signal as solenoid valve. Supports both single and double solenoid types. No homing necessary with simple absolute type.				
Splash-Proof Solenoid Valve Type		PSEP-CW-42PI-NP-2-0					
Positioner Type		PCON-C-42PI-NP-2-0	Positioning is possible for up to 512 points	512 points	DC24V	2A max.	
Safety-Compliant Positioner Type		PCON-CG-42PI-NP-2-0					
Pulse Train Input Type (Differential Line Driver)		PCON-PL-42PI-NP-2-0	Pulse train input type with differential line driver support	(-)	DC24V	2A max.	→ P525
Pulse Train Input Type (Open Collector)		PCON-PO-42PI-NP-2-0	Pulse train input type with open collector support				
Serial Communication Type		PCON-SE-42PI-N-0-0	Dedicated to serial communication	64 points			
Field Network Type		RPCON-42P	Dedicated to field network	768 points			→ P503
Program Control Type		PSEL-C-1-42PI-NP-2-0	Programmed operation is possible. Can operate up to 2 axes	1500 points			→ P557

* This is for the single-axis PSEL.

RCP3-RA2AC

RoboCylinder Mini Rod Type Motor Unit Coupling Type 22mm Width
Pulse Motor Ball Screw/Lead Screw

Configuration

RCP3 - RA2AC - I

Series	Type	Encoder	Motor	Lead	Stroke	Compatible Controllers	Cable Length	Option
I: Incremental specification * Model number is "I" when used with simple absolute unit.	20P: Pulse Motor 20□ size Standard type 20SP: Pulse Motor 20□ size High-load type	4: Ball screw 4mm 2: Ball screw 2mm 1: Ball screw 1mm 4S: Lead screw 4mm 2S: Lead screw 2mm 1S: Lead screw 1mm	25: 25mm 100: 100mm (every 25mm)	P1: PCON RPCON PSEL P3: PMEC PSEP	N: None P: 1m S: 3m M: 5m X□□: Custom Length	B: Brake NM: Reversed-home specification		

* See page Pre-35 for details on the model descriptions.

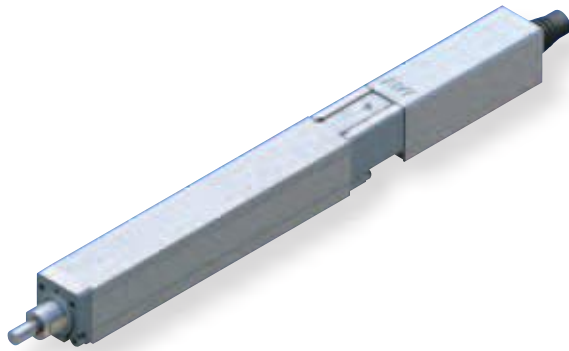

Technical References P. A-5



- (1) The payload is the value when the actuator is operated at an acceleration of 0.3 G (0.2 G for the lead screw specification, if used vertically). The acceleration limit is the value indicated above.
- (2) The horizontal payload is the value when used in combination with an external guide. Please note that if an external force is applied to the rod in a direction other than the proper direction the rod travels, the detent may get damaged.
- (3) The maximum pushing force is the value when the actuator is operated at a speed of 5 mm/s.
- (4) Service life decreases significantly if used in a dusty environment.

Correlation Diagrams of Speed and Load Capacity

With the RCP3 series, due to the characteristics of the pulse motor, load capacity decreases as the speed increases. Use the chart below to confirm that the desired speed and load capacity requirements are met.

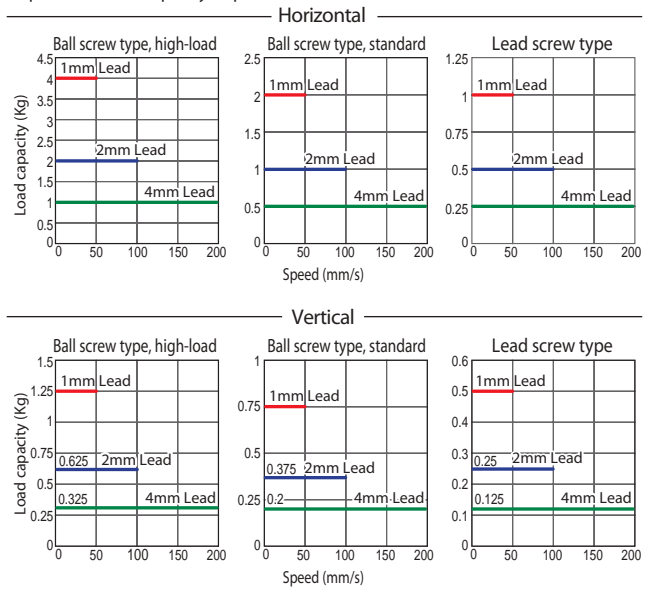

Actuator Specifications

Lead and Load Capacity

Model	Motor type	Feed screw	Lead (mm)	Maximum payload		Maximum pushing force (N)	Positioning Repeatability (mm)	Stroke (mm)			
				Horizontal (kg)	Vertical (kg)						
RCP3-RA2AC-I-20SP-4-①-②-③-④	High-load	Ball screw	4	1	0.325	See page A-68	±0.02	25 to 100 (every 25mm)			
RCP3-RA2AC-I-20SP-2-①-②-③-④			2	2	0.625						
RCP3-RA2AC-I-20SP-1-①-②-③-④			1	4	1.25						
RCP3-RA2AC-I-20P-4-①-②-③-④	Standard	Ball screw	4	0.5	0.2						
RCP3-RA2AC-I-20P-2-①-②-③-④			2	1	0.375						
RCP3-RA2AC-I-20P-1-①-②-③-④			1	2	0.75						
RCP3-RA2AC-I-20P-4S-①-②-③-④	Standard	Lead screw	4	0.25	0.125				±0.05		
RCP3-RA2AC-I-20P-2S-①-②-③-④			2	0.5	0.25						
RCP3-RA2AC-I-20P-1S-①-②-③-④			1	1	0.5						

Legend ① Stroke ② Compatible Controllers ③ Cable length ④ Option

Stroke and Maximum Speed

Lead	Stroke	Maximum Speed (mm/s)	
		25 (mm)	50 to 100 (mm)
Ball screw	4	180	200
	2	100	
	1	50	
Lead screw	4	180	200
	2	100	
	1	50	

(Unit = mm/s)

Cable List

Type	Cable Symbol
Standard (Robot Cables)	P (1m)
	S (3m)
	M (5m)
Special Lengths	X06 (6m) ~ X10 (10m)
	X11 (11m) ~ X15 (15m)
	X16 (16m) ~ X20 (20m)

* The RCP3 comes standard with a robot cable.
* See page A-39 for cables for maintenance.

Option List

Name	Option Code	See Page
Brake	B	→ A-25
Reversed-home	NM	→ A-33

Actuator Specifications

Item	Description
Drive System	Ball screw/Lead screw, Ø4 mm, rolled C10
Lost motion	Ball screw: 0.1 mm or less/Lead screw: 0.3 mm or less (default value)
Base	Material: Aluminum, white alumite treated
Guide	Slide guide
Ambient operating temperature, humidity	0 to 40 °C, 85% RH or less (Non-condensing)
Service life	Lead screw specification Horizontal: 10 million cycles Vertical: 5 million cycles
	Ball screw specification

Dimensions

CAD drawings can be downloaded from IAI website. www.robocylinder.de

For Special Orders P. A-9



- *1 A motor-encoder cable is connected here. See page A-39 for details on cables.
- *2 When homing, the slider moves to the mechanical end; therefore, please watch for any interference with the surrounding objects.

(with brake)

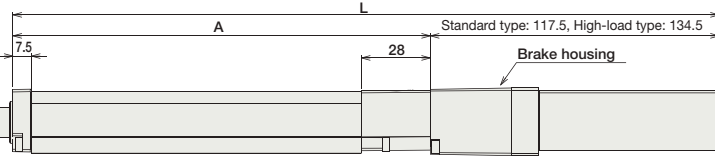
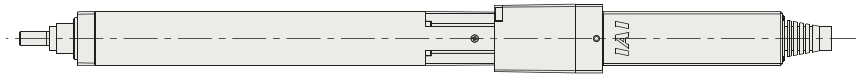

* The bottom of the brake housing protrudes from the actuator's mounting surface by 1mm. Please use caution when mounting.

(without brake)

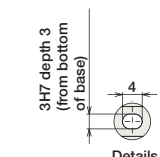
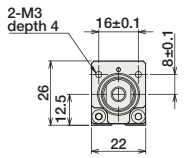
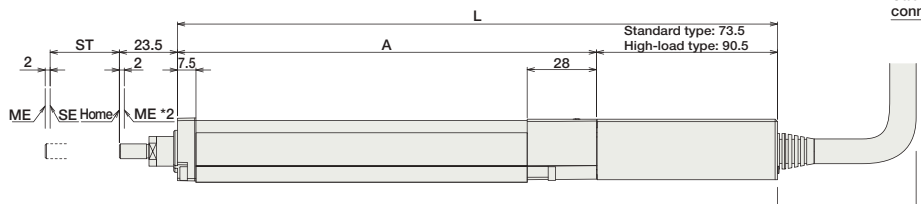
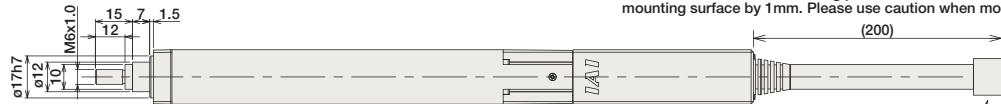

Details of Z

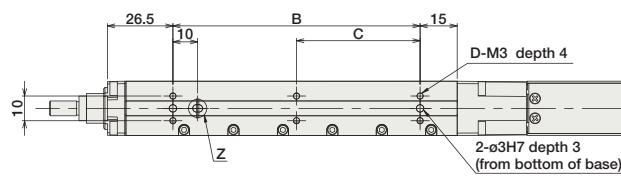

Secure at least 100
ST : Stroke
ME : Mechanical end
SE : Stroke end

* Adding a brake will increase the actuator's weight by 0.1kg.

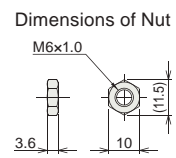

■ Dimensions/Weight by Stroke

Stroke		25	50	75	100	
L	Standard type	No brake	168	193	218	243
		Brake-equipped	212	237	262	287
	High-load type	No brake	185	210	235	260
		Brake-equipped	229	254	279	304
A		94.5	119.5	144.5	169.5	
B		25	50	75	100	
C		0	0	0	50	
D		4	4	4	6	
Mass (kg)		0.31	0.33	0.36	0.37	

Compatible Controllers

The RCP3 series actuators can operate with the controllers below. Select the controller according to your usage.

Name	External View	Model	Description	Max. Positioning Points	Input Voltage	Power Supply Capacity	See Page
Solenoid Valve Type		PMEC-C-20PI-NP-2-2	Easy-to-use controller, even for beginners	3 points	AC115V AC230V	See P481	→ P477
		PSEP-C-20PI-NP-2-0	Operable with same signal as solenoid valve. Supports both single and double solenoid types. No homing necessary with simple absolute type.				
Splash-Proof Solenoid Valve Type		PSEP-CW-20PI-NP-2-0					
Positioner Type		PCON-C-20PI-NP-2-0	Positioning is possible for up to 512 points	512 points			
Safety-Compliant Positioner Type		PCON-CG-20PI-NP-2-0					
Pulse Train Input Type (Differential Line Driver)		PCON-PL-20PI-NP-2-0	Pulse train input type with differential line driver support	(-)	DC24V	2A max.	→ P525
Pulse Train Input Type (Open Collector)		PCON-PO-20PI-NP-2-0	Pulse train input type with open collector support				
Serial Communication Type		PCON-SE-20PI-N-0-0	Dedicated to serial communication	64 points			
Field Network Type		RPCON-20P	Dedicated to field network	768 points			→ P503
Program Control Type		PSEL-C-1-20PI-NP-2-0	Programmed operation is possible. Operation is possible on up to 2 axes	1500 points			→ P557

* This is for the single-axis PSEL.

- Slider Type
- Mini
- Standard
- Controllers Integrated
- Rod Type
- Mini
- Standard
- Controllers Integrated
- Table/Arm /Flat Type
- Mini
- Standard
- Gripper/ Rotary Type
- Linear Motor Type
- Cleanroom Type
- Splash Proof
- Controllers
- PMEC /AMEC
- PSEP /ASEP
- ROBO NET
- ERC2
- PCON
- ACON
- SCON
- PSEL
- ASEL
- SSEL
- XSEL
- Pulse Motor
- Servo Motor (24V)
- Servo Motor (230V)
- Linear Motor

RCP3-RA2BC

RoboCylinder Mini Rod type Motor Unit Coupling type 28mm Width Pulse Motor Ball Screw/Lead Screw

Configuration

RCP3 - RA2BC - I

Series	Type	Encoder	Motor	Lead	Stroke	Compatible Controllers	Cable Length	Option
I: Incremental specification * Model number is "I" when used with simple absolute unit.	20P: Pulse Motor 20□ size Standard type 20SP: Pulse Motor 20□ size High-load type	6: Ball screw 6mm 4: Ball screw 4mm 2: Ball screw 2mm 1: Ball screw 1mm 6S: Lead screw 6mm 4S: Lead screw 4mm 2S: Lead screw 2mm	25: 25 mm 150: 150 mm (every 25mm)	P1: PCON RPCON PSEL P3: PMEC PSEP	N: None P: 1m S: 3m M: 5m X□□: Custom Length	B: Brake NM: Reversed-home specification		

*See page Pre-35 for details on the model descriptions.

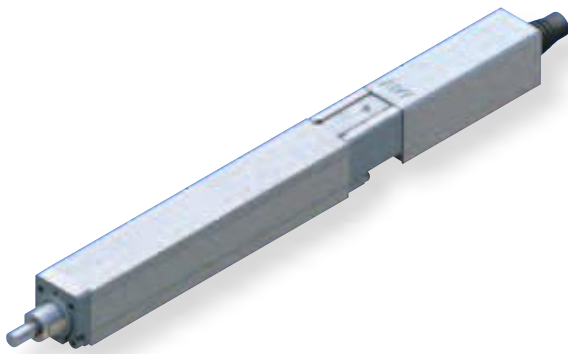

Technical References P. A-5



- The payload is the value when the actuator is operated at an acceleration of 0.3 G (0.2 G for the lead screw specification, if used vertically). The acceleration limit is the value indicated above.
- The horizontal payload is the value when used in combination with an external guide. Please note that if an external force is applied to the rod in a direction other than the proper direction the rod travels, the detent may get damaged.
- The maximum pushing force is the value when the actuator is operated at a speed of 5 mm/s.
- Service life decreases significantly if used in a dusty environment.

Correlation Diagrams of Speed and Load Capacity

With the RCP3 series, due to the characteristics of the pulse motor, load capacity decreases as the speed increases. Use the chart below to confirm that the desired speed and load capacity requirements are met.

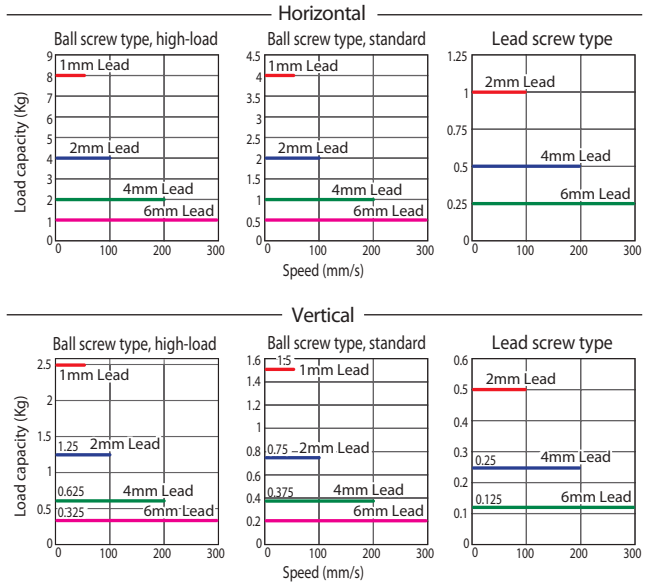

Actuator Specifications

Lead and Load Capacity

Model	Motor type	Feed screw	Lead (mm)	Maximum payload		Maximum pushing force (N)	Positioning Repeatability (mm)	Stroke (mm)			
				Horizontal (kg)	Vertical (kg)						
RCP3-RA2BC-I-20SP-6-①-②-③-④	High-load	Ball screw	6	1	0.325	See page A-68	±0.02	25 to 150 (every 25mm)			
RCP3-RA2BC-I-20SP-4-①-②-③-④			4	2	0.625						
RCP3-RA2BC-I-20SP-2-①-②-③-④			2	4	1.25						
RCP3-RA2BC-I-20SP-1-①-②-③-④			1	8	2.5						
RCP3-RA2BC-I-20P-6-①-②-③-④	Standard	Ball screw	6	0.5	0.2						
RCP3-RA2BC-I-20P-4-①-②-③-④			4	1	0.375						
RCP3-RA2BC-I-20P-2-①-②-③-④			2	2	0.75						
RCP3-RA2BC-I-20P-1-①-②-③-④			1	4	1.5						
RCP3-RA2BC-I-20P-6S-①-②-③-④	Standard	Lead screw	6	0.25	0.125				±0.05		
RCP3-RA2BC-I-20P-4S-①-②-③-④			4	0.5	0.25						
RCP3-RA2BC-I-20P-2S-①-②-③-④			2	1	0.5						

Legend ① Stroke ② Compatible Controllers ③ Cable length ④ Option

Stroke and Maximum Speed

Lead	Stroke	Stroke		
		25 (mm)	50 (mm)	75 to 150 (mm)
Ball screw	6	180	280	300
	4	180	200	
	2	100		
	1	50		
Lead screw	6	180	280	300
	4	180	200	
	2	100		

(Unit = mm/s)

Cable list

Type	Cable symbol
Standard type (Robot cable)	P (1m)
	S (3m)
	M (5m)
Special length	X06 (6m) to X10 (10m)
	X11 (11m) to X15 (15m)
	X16 (16m) to X20 (20m)

* The RCP3 comes standard with a robot cable.
* See page A-39 for cables for maintenance.

Option List

Title	Option code	See page
Brake	B	→ A-25
Reversed - home specification	NM	→ A-33

Actuator Specifications

Item	Description
Drive System	Ball screw/Lead screw, Ø6 mm, rolled C10
Lost motion	Ball screw: 0.1 mm or less/Lead screw: 0.3 mm or less (default value)
Base	Material: Aluminum, white alumite treated
Guide	Slide guide
Ambient operating temperature, humidity	0 to 40 °C, 85% RH or less (Non-condensing)
Service life	Lead screw specification Horizontal: 10 million cycles Vertical: 5 million cycles
	Ball screw specification

- Slider Type
- Mini
- Standard
- Controllers Integrated
- Rod Type
- Mini
- Standard
- Controllers Integrated
- Table/Arm /Flat Type
- Mini
- Standard
- Gripper/ Rotary Type
- Linear Motor Type
- Cleanroom Type
- Splash Proof
- Controllers
- PMEC /AMEC
- PSEP /ASEP
- ROBO NET
- ERC2
- PCON
- ACON
- SCON
- PSEL
- ASEL
- SSEL
- XSEL
- Pulse Motor
- Servo Motor (24V)
- Servo Motor (230V)
- Linear Motor

Dimensions

CAD drawings can be downloaded from IAI website. www.robocylinder.de

For Special Orders P. A-9



- *1 A motor-encoder cable is connected here. See page A-39 for details on cables.
- *2 When homing, the slider moves to the mechanical end; therefore, please watch for any interference with the surrounding objects.

(with brake)

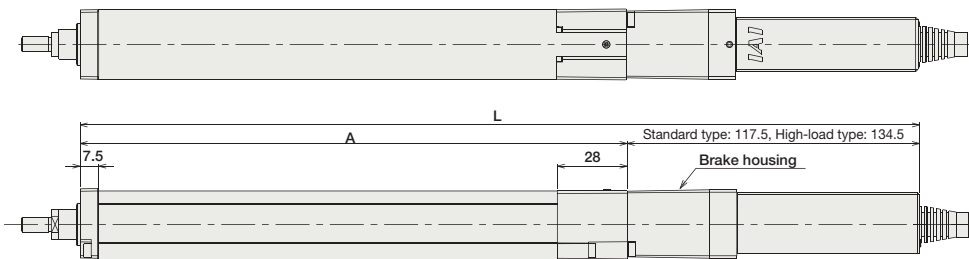

(without brake)

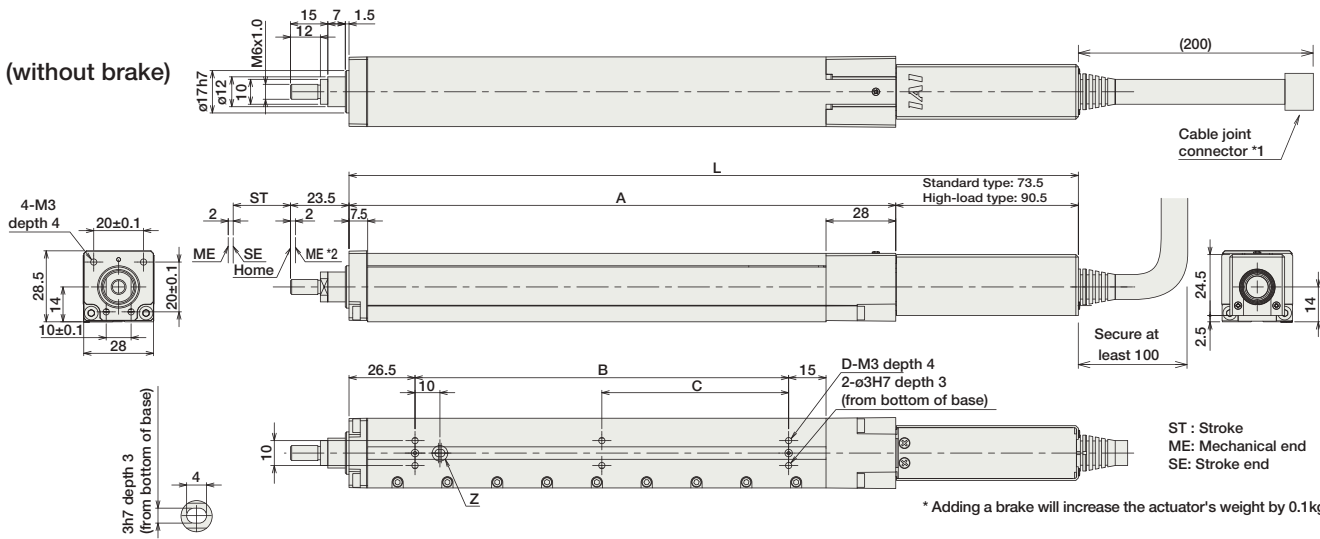

* Adding a brake will increase the actuator's weight by 0.1kg.

Dimensions and Weight by Stroke

		Stroke	25	50	75	100	125	150
L	Standard type	No brake	168	193	218	243	268	293
		Brake-equipped	212	237	262	287	312	337
	High-load type	No brake	185	210	235	260	285	310
		Brake-equipped	229	254	279	304	329	354
A			94.5	119.5	144.5	169.5	194.5	219.5
B			25	50	75	100	125	150
C			0	0	0	50	62.5	75
D			4	4	4	6	6	6
Mass (kg)			0.36	0.39	0.42	0.45	0.48	0.51

Compatible Controllers

The RCP3 series actuators can operate with the controllers below. Select the controller according to your usage.

Name	External View	Model	Description	Max. Positioning Points	Input Voltage	Power Supply Capacity	See Page
Solenoid Valve Type		PMEC-C-20PI-NP-2-2	Easy-to-use controller, even for beginners	3 points	AC115V AC230V	See P481	→ P477
	Splash-Proof Solenoid Valve Type		PSEP-C-20PI-NP-2-0				
Positioner Type			PCON-C-20PI-NP-2-0	Positioning is possible for up to 512 points	512 points		
Safety-Compliant Positioner Type		PCON-CG-20PI-NP-2-0					
Pulse Train Input Type (Differential Line Driver)		PCON-PL-20PI-NP-2-0	Pulse train input type with differential line driver support	(-)	DC24V	2A max.	→ P525
Pulse Train Input Type (Open Collector)		PCON-PO-20PI-NP-2-0	Pulse train input type with open collector support				
Serial Communication Type		PCON-SE-20PI-N-0-0	Dedicated to serial communication	64 points			
Field Network Type		RPCON-20P	Dedicated to field network	768 points			→ P503
Program Control Type		PSEL-C-1-20PI-NP-2-0	Programmed operation is possible. Operation is possible on up to 2 axes	1500 points			→ P557

* This is for the single-axis PSEL.

RCP3-RA2AR

RoboCylinder Mini Rod type Side-Mounted Motor Type 22mm Width Pulse Motor Ball Screw/Lead Screw

Configuration

RCP3 - RA2AR - I

I: Incremental specification
* Model number is "I" when used with simple absolute unit.

20P: Pulse Motor 20□ size Standard type
20SP: Pulse Motor 20□ size High-load type

4: Ball screw 4mm
2: Ball screw 2mm
1: Ball screw 1mm
4S: Lead screw 4mm
2S: Lead screw 2mm
1S: Lead screw 1mm

Compatible Controllers
P1: PCON
RPCON
PSEL
P3: PMEC
PSEP

Cable Length
N: None
P: 1m
S: 3m
M: 5m
X□□: Custom Length

Option
See options table below.
* Be sure to specify which side the motor is to be mounted (ML/MR)

* See page Pre-35 for details on the model descriptions.

Technical References

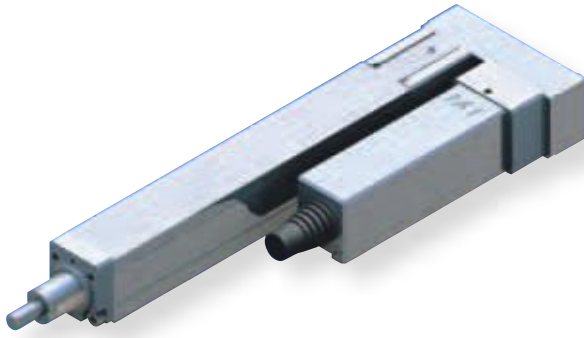

Photo above shows specification with motor reversing to the left (ML Option).



- The payload is the value when the actuator is operated at an acceleration of 0.3 G (0.2 G for the lead screw specification, if used vertically). The acceleration limit is the value indicated above.
- The horizontal payload is the value when used in combination with an external guide. Please note that if an external force is applied to the rod in a direction other than the proper direction the rod travels, the detent may get damaged.
- The maximum pushing force is the value when the actuator is operated at a speed of 5 mm/s.
- Service life decreases significantly if used in a dusty environment.

Correlation Diagrams of Speed and Load Capacity

With the RCP3 series, due to the characteristics of the pulse motor, load capacity decreases as the speed increases. Use the chart below to confirm that the desired speed and load capacity requirements are met.

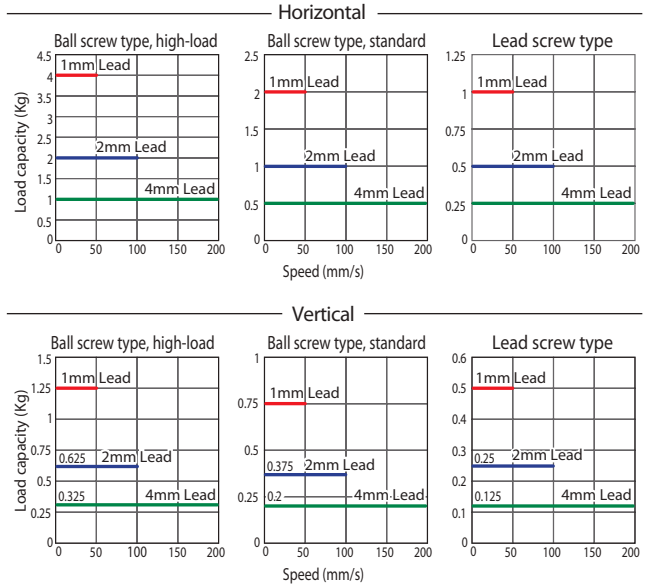

Actuator Specifications

Lead and Load Capacity

Model	Motor type	Feed screw	Lead (mm)	Maximum payload		Maximum pushing force (N)	Positioning Repeatability (mm)	Stroke (mm)			
				Horizontal (kg)	Vertical (kg)						
RCP3-RA2AR-I-20SP-4-①-②-③-④	High-load	Ball screw	4	1	0.325	See page A-68	±0.02	25 to 100 (every 25mm)			
RCP3-RA2AR-I-20SP-2-①-②-③-④			2	2	0.625						
RCP3-RA2AR-I-20SP-1-①-②-③-④			1	4	1.25						
RCP3-RA2AR-I-20P-4-①-②-③-④	Standard	Ball screw	4	0.5	0.2						
RCP3-RA2AR-I-20P-2-①-②-③-④			2	1	0.375						
RCP3-RA2AR-I-20P-1-①-②-③-④			1	2	0.75						
RCP3-RA2AR-I-20P-4S-①-②-③-④	Standard	Lead screw	4	0.25	0.125				±0.05	±0.05	
RCP3-RA2AR-I-20P-2S-①-②-③-④			2	0.5	0.25						
RCP3-RA2AR-I-20P-1S-①-②-③-④			1	1	0.5						

Stroke and Maximum Speed

Lead	Stroke	Maximum Speed	
		25 (mm)	50 to 100 (mm)
Ball screw	4	180	200
	2	100	
	1	50	
Lead screw	4	180	200
	2	100	
	1	50	

(Unit = mm/s)

Legend ① Stroke ② Compatible Controllers ③ Cable length ④ Option

Cable List

Type	Cable Symbol
Standard (Robot Cables)	P (1m)
	S (3m)
	M (5m)
Special Lengths	X06 (6m) ~ X10 (10m)
	X11 (11m) ~ X15 (15m)
	X16 (16m) ~ X20 (20m)

* The RCP3 comes standard with a robot cable.

* See page A-39 for cables for maintenance.

Option List

Title	Option code	See page
Brake	B	→ A-25
Side-mounted motor to the left (standard)	ML	→ A-33
Side-mounted motor to the right	MR	→ A-33
Reversed-home specification	NM	→ A-33

Actuator Specifications

Item	Description
Drive System	Ball screw/Lead screw, Ø4 mm, rolled C10
Lost motion	Ball screw: 0.1 mm or less/Lead screw: 0.3 mm or less (default value)
Base	Material: Aluminum, white alumite treated
Guide	Slide guide
Ambient operating temperature, humidity	0 to 40 °C, 85% RH or less (Non-condensing)
Service life	Lead screw specification
	Ball screw specification

Dimensions

CAD drawings can be downloaded from IAI website. www.robocylinder.de

2/3D CAD

* The figure below shows the left-mounted motor model

(with brake)

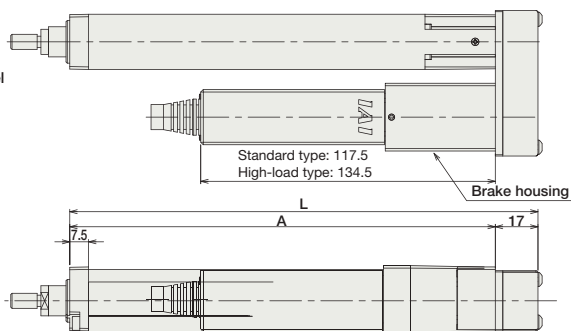

(without brake)

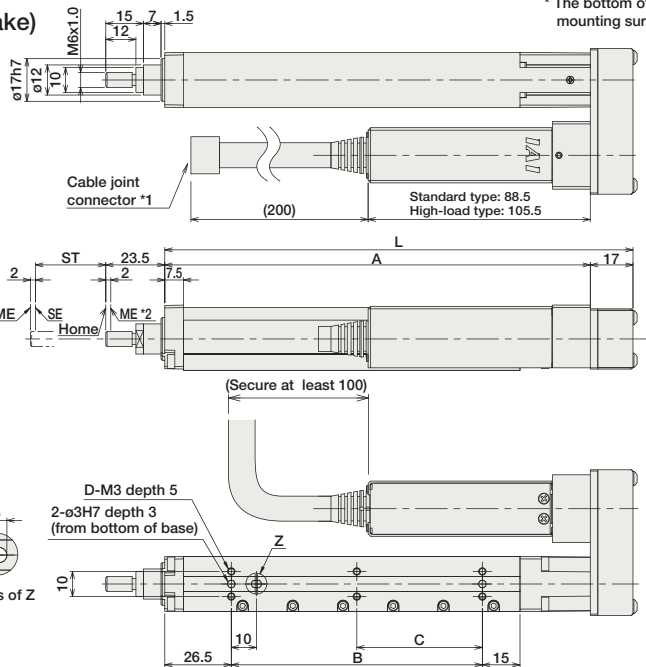

* The bottom of the brake housing protrudes from the actuator's mounting surface by 1mm. Please use caution when mounting.

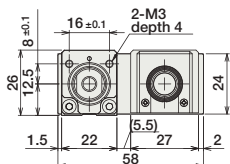

3H7 depth 3 (from bottom of base)



Dimensions of Nut

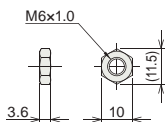

For Special Orders P. A-9

*1 A motor-encoder cable is connected here. See page A-39 for details on cables.

*2 When homing, the slider moves to the mechanical end; therefore, please watch for any interference with the surrounding objects.



ST : Stroke
ME : Mechanical end
SE : Stroke end

* Adding a brake will increase the actuator's weight by 0.1kg.

Dimensions/Weight by Stroke

Stroke	25	50	75	100
L	111.5	136.5	161.5	186.5
A	94.5	119.5	144.5	169.5
B	25	50	75	100
C	0	0	0	50
D	4	4	4	6
Weight (kg)	0.34	0.36	0.39	0.4

Compatible Controllers

The RCP3 series actuators can operate with the controllers below. Select the controller according to your usage.

Name	External View	Model	Description	Max. Positioning Points	Input Voltage	Power Supply Capacity	See Page
Solenoid Valve Type		PMEC-C-20PI-NP-2-2	Easy-to-use controller, even for beginners	3 points	AC115V AC230V	See P481	→ P477
		PSEP-C-20PI-NP-2-0	Operable with same signal as solenoid valve. Supports both single and double solenoid types. No homing necessary with simple absolute type.				
Splash-Proof Solenoid Valve Type		PSEP-CW-20PI-NP-2-0					
Positioner Type		PCON-C-20PI-NP-2-0	Positioning is possible for up to 512 points	512 points			
Safety-Compliant Positioner Type		PCON-CG-20PI-NP-2-0					
Pulse Train Input Type (Differential Line Driver)		PCON-PL-20PI-NP-2-0	Pulse train input type with differential line driver support	(-)	DC24V	2A max.	→ P525
Pulse Train Input Type (Open Collector)		PCON-PO-20PI-NP-2-0	Pulse train input type with open collector support				
Serial Communication Type		PCON-SE-20PI-N-0-0	Dedicated to serial communication	64 points			
Field Network Type		RPCON-20P	Dedicated to field network	768 points			→ P503
Program Control Type		PSEL-C-1-20PI-NP-2-0	Programmed operation is possible. Operation is possible on up to 2 axes	1500 points			→ P557

* This is for the single-axis PSEL.

Slider Type

Mini

Standard

Controllers Integrated

Rod Type

Mini

Standard

Controllers Integrated

Table/Arm /Flat Type

Mini

Standard

Gripper/ Rotary Type

Linear Motor Type

Cleanroom Type

Splash Proof

Controllers

PMEC /AMEC

PSEP /ASEP

ROBO NET

ERC2

PCON

ACON

SCON

PSEL

ASEL

SSEL

XSEL

Pulse Motor

Servo Motor (24V)

Servo Motor (230V)

Linear Motor

RCP3-RA2BR

RoboCylinder Mini Rod type Side-Mounted Motor Type 28mm Width Pulse Motor Ball Screw/Lead Screw

Configuration

RCP3 - RA2BR - I

Series — Type — Encoder — Motor — Lead — Stroke — Compatible Controllers — Cable Length — Option

I: Incremental specification
* Model number is "I" when used with simple absolute unit.

20P: Pulse Motor 20□ size
Standard type
20SP: Pulse Motor 20□ size
High-load type

6: Ball screw 6mm
4: Ball screw 4mm
2: Ball screw 2mm
1: Ball screw 1mm
6S: Lead screw 6mm
4S: Lead screw 4mm
2S: Lead screw 2mm

P1: PCON
RPCON
PSEL
P3: PMEC
PSEP

N: None
P: 1m
S: 3m
M: 5m
X□□: Custom Length

See options table below.
* Be sure to specify which side the motor is to be mounted (ML/MR)

* See page Pre-35 for details on the model descriptions.

Technical References

P. A-5

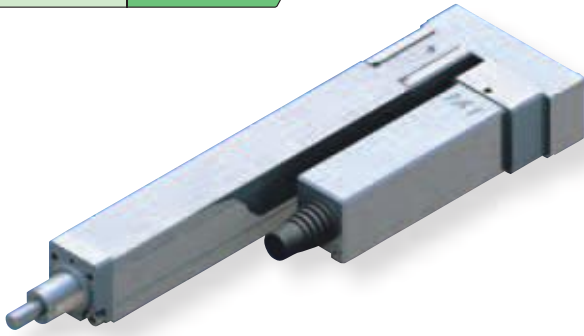

Photo above shows specification with motor reversing to the left (ML Option).



- The payload is the value when the actuator is operated at an acceleration of 0.3 G (0.2 G for the lead screw specification, if used vertically). The acceleration limit is the value indicated above.
- The horizontal payload is the value when used in combination with an external guide. Please note that if an external force is applied to the rod in a direction other than the proper direction the rod travels, the detent may get damaged.
- The maximum pushing force is the value when the actuator is operated at a speed of 5 mm/s.
- Service life decreases significantly if used in a dusty environment.

Correlation Diagrams of Speed and Load Capacity

With the RCP3 series, due to the characteristics of the pulse motor, load capacity decreases as the speed increases. Use the chart below to confirm that the desired speed and load capacity requirements are met.

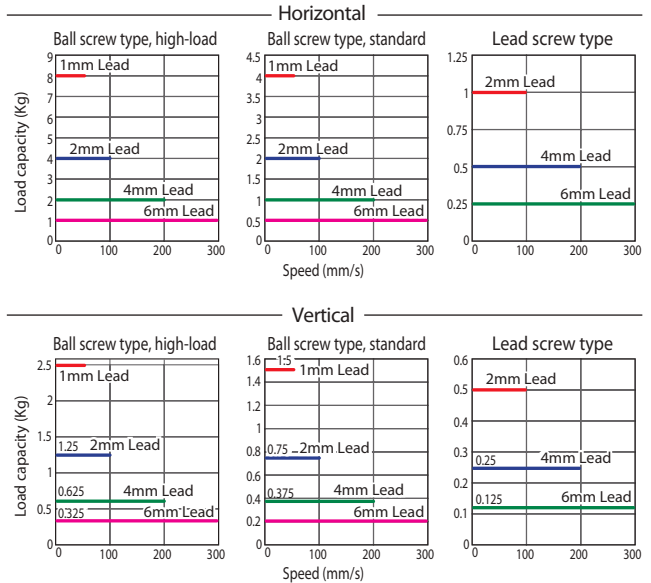

Actuator Specifications

Lead and Load Capacity

Model	Motor type	Feed screw	Lead (mm)	Maximum payload		Maximum pushing force (N)	Positioning Repeatability (mm)	Stroke (mm)
				Horizontal (kg)	Vertical (kg)			
RCP3-RA2BR-I-20SP-6-①-②-③-④	High-load	Ball screw	6	1	0.325	See page A-68	±0.02	25 to 150 (every 25mm)
RCP3-RA2BR-I-20SP-4-①-②-③-④			4	2	0.625			
RCP3-RA2BR-I-20SP-2-①-②-③-④			2	4	1.25			
RCP3-RA2BR-I-20SP-1-①-②-③-④			1	8	2.5			
RCP3-RA2BR-I-20P-6-①-②-③-④	Standard	Ball screw	6	0.5	0.2			
RCP3-RA2BR-I-20P-4-①-②-③-④			4	1	0.375			
RCP3-RA2BR-I-20P-2-①-②-③-④			2	2	0.75			
RCP3-RA2BR-I-20P-1-①-②-③-④			1	4	1.5			
RCP3-RA2BR-I-20P-6S-①-②-③-④	Standard	Lead screw	6	0.25	0.125			
RCP3-RA2BR-I-20P-4S-①-②-③-④			4	0.5	0.25			
RCP3-RA2BR-I-20P-2S-①-②-③-④			2	1	0.5			

Legend ① Stroke ② Compatible Controllers ③ Cable length ④ Option

Stroke and Maximum Speed

Lead	Stroke	Maximum Speed		
		25 (mm)	50 (mm)	75 to 150 (mm)
Ball screw	6	180	280	300
	4	180	200	
	2	100		
	1	50		
Lead screw	6	180	280	300
	4	180	200	
	2	100		

(Unit = mm/s)

Cable List

Type	Cable Symbol
Standard (Robot Cables)	P (1m)
	S (3m)
	M (5m)
Special Lengths	X06 (6m) ~ X10 (10m)
	X11 (11m) ~ X15 (15m)
	X16 (16m) ~ X20 (20m)

* The RCP3 comes standard with a robot cable.
* See page A-39 for cables for maintenance.

Option List

Name	Option Code	See Page
Brake	B	→ A-25
Left-Mounted Motor (Standard)	ML	→ A-33
Right-Mounted Motor	MR	→ A-33
Reversed-home	NM	→ A-33

Actuator Specifications

Item	Description
Drive System	Ball screw/Lead screw, Ø6 mm, rolled C10
Lost motion	Ball screw: 0.1 mm or less/Lead screw: 0.3 mm or less (default value)
Base	Material: Aluminum, white alumite treated
Guide	Slide guide
Ambient operating temperature, humidity	0 to 40 °C, 85% RH or less (Non-condensing)
Service life	Lead screw specification
	Ball screw specification

Dimensions

CAD drawings can be downloaded from IAI website. www.robocylinder.de



* The diagram below shows a left-mounted motor model.

For Special Orders P. A-9

(with brake)

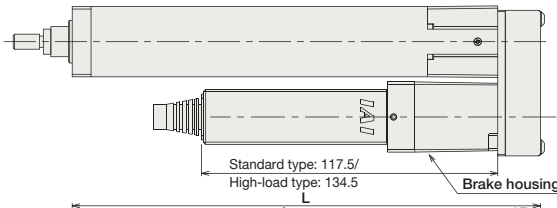

- *1 A motor-encoder cable is connected here. See page A-39 for details on cables.
- *2 When homing, the slider moves to the mechanical end; therefore, please watch for any interference with the surrounding objects.

(without brake)

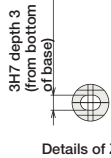
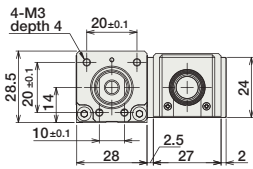
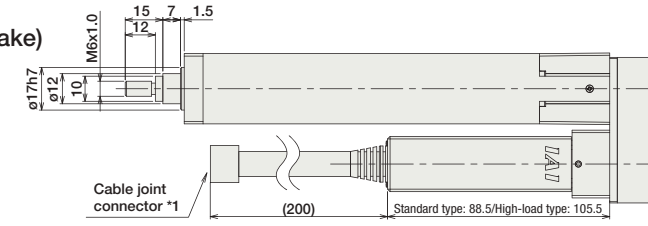

Dimensions of Nut

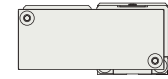
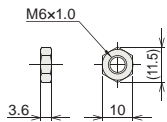

ST : Stroke
ME : Mechanical end
SE : Stroke end

* Adding a brake will increase the actuator's weight by 0.1kg.

Dimensions/Weight by Stroke

Stroke	25	50	75	100	125	150
L	111.5	136.5	161.5	186.5	211.5	236.5
A	94.5	119.5	144.5	169.5	194.5	219.5
B	25	50	75	100	125	150
C	0	0	0	50	62.5	75
D	4	4	4	6	6	6
Weight (kg)	0.38	0.41	0.44	0.47	0.50	0.53

Compatible Controllers

The RCP3 series actuators can operate with the controllers below. Select the controller according to your usage.

Name	External View	Model	Description	Max. Positioning Points	Input Voltage	Power Supply Capacity	See Page
Solenoid Valve Type		PMEC-C-20PI-NP-2-2	Easy-to-use controller, even for beginners	3 points	AC115V AC230V	See P481	→ P477
Splash-Proof Solenoid Valve Type		PSEP-C-20PI-NP-2-0	Operable with same signal as solenoid valve. Supports both single and double solenoid types. No homing necessary with simple absolute type.				
Positioner Type		PCON-C-20PI-NP-2-0	Positioning is possible for up to 512 points	512 points	DC24V	2A max.	→ P525
Safety-Compliant Positioner Type		PCON-CG-20PI-NP-2-0					
Pulse Train Input Type (Differential Line Driver)		PCON-PL-20PI-NP-2-0	Pulse train input type with differential line driver support	(-)	DC24V	2A max.	→ P525
Pulse Train Input Type (Open Collector)		PCON-PO-20PI-NP-2-0	Pulse train input type with open collector support				
Serial Communication Type		PCON-SE-20PI-N-0-0	Dedicated to serial communication	64 points	DC24V	2A max.	→ P503
Field Network Type		RPCON-20P	Dedicated to field network	768 points			
Program Control Type		PSEL-C-1-20PI-NP-2-0	Programmed operation is possible. Operation is possible on up to 2 axes	1500 points	DC24V	2A max.	→ P557

* This is for the single-axis PSEL.

- Slider Type
- Mini
- Standard
- Controllers Integrated
- Rod Type
- Mini
- Standard
- Controllers Integrated
- Table/Arm /Flat Type
- Mini
- Standard
- Gripper/ Rotary Type
- Linear Motor Type
- Cleanroom Type
- Splash Proof
- Controllers
- PMEC /AMEC
- PSEP /ASEP
- ROBO NET
- ERC2
- PCON
- ACON
- SCON
- PSEL
- ASEL
- SSEL
- XSEL
- Pulse Motor
- Servo Motor (24V)
- Servo Motor (230V)
- Linear Motor

- Slider Type
- Mini
- Standard
- Controllers Integrated
- Rod Type
- Mini
- Standard
- Controllers Integrated
- Table/Arm /Flat Type
- Mini
- Standard
- Gripper/ Rotary Type
- Linear Motor Type
- Cleanroom Type
- Splash Proof
- Controllers
- PMEC /AMEC
- PSEP /ASEP
- ROBO NET
- ERC2
- PCON
- ACON
- SCON
- PSEL
- ASEL
- SSEL
- XSEL
- Pulse Motor
- Servo Motor (24V)
- Servo Motor (230V)
- Linear Motor

RCP2-RA2C RoboCylinder Rod Type 25mm Width Pulse Motor Straight Type

■ Configuration: **RCP2** — **RA2C** — **I** — **20P** — — — — —

Series — Type — Encoder — Motor — Lead — Stroke — Compatible Controllers — Cable Length — Option

I: Incremental * The Simple absolute encoder is also considered type "I".
 20P: Pulse motor 20 □ size
 1 : 1mm
 25: 25mm
 \
 100: 100mm (25mm pitch increments)
 P1: PCON
 RPCON
 PSEL
 P3: PMEAC
 PSEP
 N : None
 P : 1m
 S : 3m
 M : 5m
 X □ □ : Custom Length
 R □ □ : Robot cable
 FL : Flange
 FT : Foot bracket

* See page Pre-35 for an explanation of the naming convention.

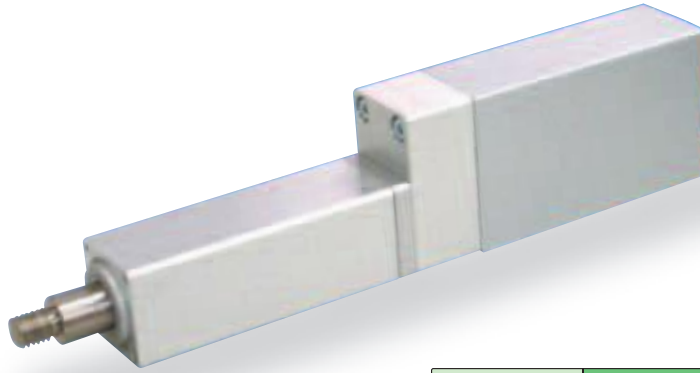

Technical References P. A-5

- POINT**
Notes on Selection
- (1) Since the RCP2 series use a pulse motor, the load capacity decreases at high speeds. Check in the Speed vs. Load Capacity graph to see if your desired speed and load capacity are supported.
 - (2) The load capacity is based on operation at an acceleration of 0.05G. 0.05G is the upper limit of the acceleration. In addition, the horizontal load capacity is based on the use of an external guide. If an external force is exerted on the rod from a direction other than the motion of the rod, the detent may become damaged.

■ Speed vs. Load Capacity
 Due to the characteristics of the pulse motor, the RCP2 series' load capacity decreases at high speeds. In the table below, check if your desired speed and load capacity are supported.

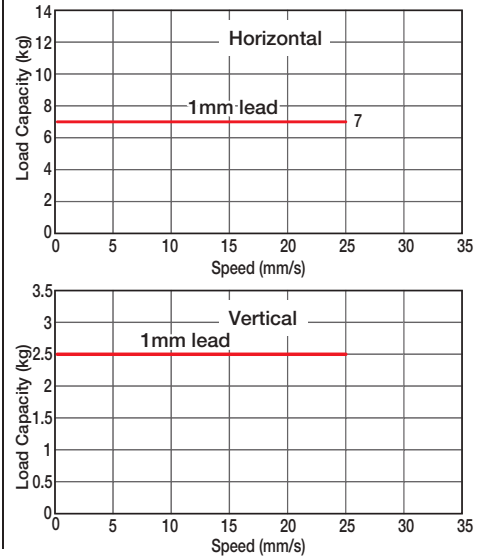

Actuator Specifications						Stroke and Maximum Speed	
■ Lead and Load Capacity						Stroke	
Model	Lead (mm)	Max. Load Capacity		Maximum Push Force (N)(Note 1)	Stroke (mm)	25 ~ 100 (25mm increments)	
		Horizontal (kg)	Vertical (kg)			Lead	Stroke
RCP2-RA2C-I-20P-1-①-②-③-④	1	7	2.5	100	25 ~ 100 (25mm increments)	1	25

Legend: ① Stroke ② Compatible controller ③ Cable length ④ Options (Note 1) See page A-69 for the pushing force graphs. (Unit: mm/s)

Type	Cable Symbol
Standard	P (1m)
	S (3m)
	M (5m)
Special Lengths	X06 (6m) ~ X10 (10m)
	X11 (11m) ~ X15 (15m)
	X16 (16m) ~ X20 (20m)
	R01 (1m) ~ R03 (3m)
Robot Cable	R04 (4m) ~ R05 (5m)
	R06 (6m) ~ R10 (10m)
	R11 (11m) ~ R15 (15m)
	R16 (16m) ~ R20 (20m)

* See page A-39 for cables for maintenance.

Item	Description
Drive System	Ball screw ø6mm C10 grade
Positioning Repeatability	±0.02mm
Lost Motion	0.1mm or less
Rod Diameter	ø12mm
Non-rotating accuracy of rod	±2.1 deg
Ambient Operating Temp./Humidity	0~40°C, 85% RH or less (non-condensing)

Name	Option Code	See Page
Flange	FL	→ A-27
Foot bracket	FT	→ A-29

Dimensions

CAD drawings can be downloaded from IAI website. www.robocylinder.de



* The RA2C is not available in reversed-home configuration, due to its construction.

For Special Orders P. A-9

Note:
Do not apply any external force on the rod from any direction other than the direction of the rod's motion. If a force is exerted on the rod in a perpendicular or rotational direction, the detent may become damaged.

- *1. The motor-encoder cable is connected here. See page A-39 for details on cables.
- *2. When homing, the rod moves to the ME; therefore, please watch for any interference with the surrounding objects.
ME: Mechanical end
SE: Stroke end

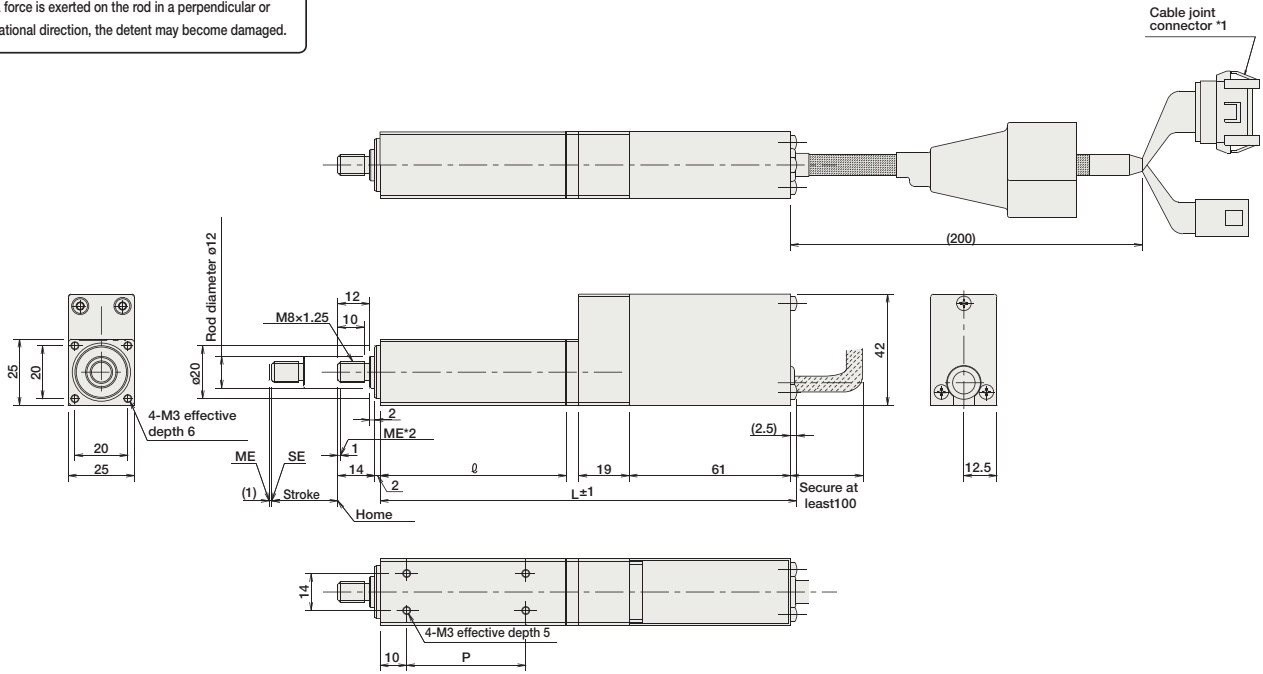

■ Dimensions/Weight by Stroke

Stroke	25	50	75	100
R	70	95	120	145
L	157.5	182.5	207.5	232.5
P	45	70	95	120
Weight (kg)	0.4	0.5	0.6	0.7

Compatible Controllers

The RCP2 series actuators can operate with the controllers below. Select the controller according to your usage.

Name	External View	Model	Description	Max. Positioning Points	Input Voltage	Power Supply Capacity	See Page
Solenoid Valve Type		PMEC-C-20PI-NP-2-2	Easy-to-use controller, even for beginners	3 points	AC115V AC230V	See P481	→ P477
		PSEP-C-20PI-NP-2-0	Operable with same signal as solenoid valve. Supports both single and double solenoid types. No homing necessary with simple absolute type.				
Splash-Proof Solenoid Valve Type		PSEP-CW-20PI-NP-2-0					
Positioner Type		PCON-C-20PI-NP-2-0	Positioning is possible for up to 512 points	512 points	DC24V	2A max.	
Safety-Compliant Positioner Type		PCON-CG-20PI-NP-2-0					
Pulse Train Input Type (Differential Line Driver)		PCON-PL-20PI-NP-2-0	Pulse train input type with differential line driver support	(-)	DC24V	2A max.	→ P525
Pulse Train Input Type (Open Collector)		PCON-PO-20PI-NP-2-0	Pulse train input type with open collector support				
Serial Communication Type		PCON-SE-20PI-N-0-0	Dedicated to serial communication	64 points			
Field Network Type		RPCON-20P	Dedicated to field network	768 points			→ P503
Program Control Type		PSEL-C-1-20PI-NP-2-0	Programmed operation is possible. Operation is possible on up to 2 axes	1500 points			→ P557

* This is for the single-axis PSEL.

- Slider Type
- Mini
- Standard
- Controllers Integrated
- Rod Type
- Mini
- Standard
- Controllers Integrated
- Table/Arm /Flat Type
- Mini
- Standard
- Gripper/ Rotary Type
- Linear Motor Type
- Cleanroom Type
- Splash Proof
- Controllers
- PMEC /AMEC
- PSEP /ASEP
- ROBO NET
- ERC2
- PCON
- ACON
- SCON
- PSEL
- ASEL
- SSEL
- XSEL
- Pulse Motor
- Servo Motor (24V)
- Servo Motor (230V)
- Linear Motor

- Slider Type
- Mini
- Standard
- Controllers Integrated
- Rod Type
- Mini
- Standard
- Controllers Integrated
- Table/Arm /Flat Type
- Mini
- Standard
- Gripper/ Rotary Type
- Linear Motor Type
- Cleanroom Type
- Splash Proof
- Controllers
- PMEC /AMEC
- PSEP /ASEP
- ROBO NET
- ERC2
- PCON
- ACON
- SCON
- PSEL
- ASEL
- SSEL
- XSEL
- Pulse Motor
- Servo Motor (24V)
- Servo Motor (230V)
- Linear Motor

RCP2-RA3C RoboCylinder Rod Type 35mm Width Pulse Motor Straight Type

■ Configuration: **RCP2** — **RA3C** — **I** — **28P** — — — — —

Series	Type	Encoder	Motor	Lead	Stroke	Compatible Controllers	Cable Length	Option
I: Incremental * The Simple absolute encoder is also considered type "I".	28P: Pulse motor 28 □ size	5 : 5mm 2.5 : 2.5mm	50: 50mm 200: 200mm (50mm pitch increments)	P1: PCON RCON PSEL P3: PMEC PSEP	N : None P : 1m S : 3m M : 5m X □ : Custom R □ : Robot cable	FL : Flange FT : Foot bracket NM : Reversed-home		

* See page Pre-35 for an explanation of the naming convention.



Technical References P. A-5

- POINT** Notes on Selection
- When the stroke increases, the maximum speed will drop to prevent the ball screw from reaching the critical rotational speed. Use the actuator specification table below to check the maximum speed at the stroke you desire.
 - Since the RCP2 series use a pulse motor, the load capacity decreases at high speeds. Check in the Speed vs. Load Capacity graph to see if your desired speed and load capacity are supported.
 - The load capacity is based on operation at an acceleration of 0.2G. In addition, the horizontal load capacity is based on the use of an external guide. If an external force is exerted on the rod from a direction other than the motion of the rod, the detent may become damaged.

■ Speed vs. Load Capacity
Due to the characteristics of the pulse motor, the RCP2 series' load capacity decreases at high speeds. In the table below, check if your desired speed and load capacity are supported.

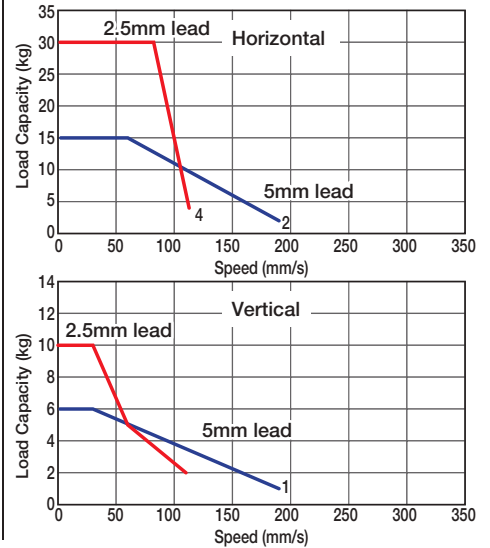

Actuator Specifications

Lead and Load Capacity

(Note 1) Please note that the maximum load capacity decreases as the speed increases.

Model	Lead (mm)	Max. Load Capacity (Note 1)		Maximum Push Force (N)(Note 2)	Stroke (mm)
		Horizontal (kg)	Vertical (kg)		
RCP2-RA3C-I-28P-5-①-②-③-④	5	~ 15	~ 6	73.5	50 ~ 200 (50mm increments)
RCP2-RA3C-I-28P-2.5-①-②-③-④	2.5	~ 30	~ 10	156.8	

Legend: ① Stroke ② Compatible controller ③ Cable length ④ Options

(Note 2) See page A-69 for the pushing force graphs.

(Unit: mm/s)

Stroke and Maximum Speed

Lead	Stroke	50 ~ 200 (50mm increments)
		5
2.5		114

Cable List

Type	Cable Symbol
Standard	P (1m)
	S (3m)
	M (5m)
Special Lengths	X06 (6m) ~ X10 (10m)
	X11 (11m) ~ X15 (15m)
	X16 (16m) ~ X20 (20m)
Robot Cable	R01 (1m) ~ R03 (3m)
	R04 (4m) ~ R05 (5m)
	R06 (6m) ~ R10 (10m)
	R11 (11m) ~ R15 (15m)
	R16 (16m) ~ R20 (20m)

* See page A-39 for cables for maintenance.

Actuator Specifications

Item	Description
Drive System	Ball screw ø8mm C10 grade
Positioning Repeatability	±0.02mm
Lost Motion	0.1mm or less
Rod Diameter	ø22mm
Non-rotating accuracy of rod	±1.5 deg
Ambient Operating Temp./Humidity	0 ~ 40°C, 85% RH or less (non-condensing)

Option List

Name	Option Code	See Page
Flange	FL	→ A-27
Foot bracket	FT	→ A-29
Reversed-home	NM	→ A-33

Dimensions

CAD drawings can be downloaded from IAI website. www.robocylinder.de



Note:
Do not apply any external force on the rod from any direction other than the direction of the rod's motion. If a force is exerted on the rod in a perpendicular or rotational direction, the detent may become damaged.

For Special Orders P. A-9

- *1. The motor-encoder cable is connected here. See page A-39 for details on cables.
- *2. When homing, the rod moves to the ME; therefore, please watch for any interference with the surrounding objects.
ME: Mechanical end
SE: Stroke end
- *3. The orientation of the bolt will vary depending on the product.

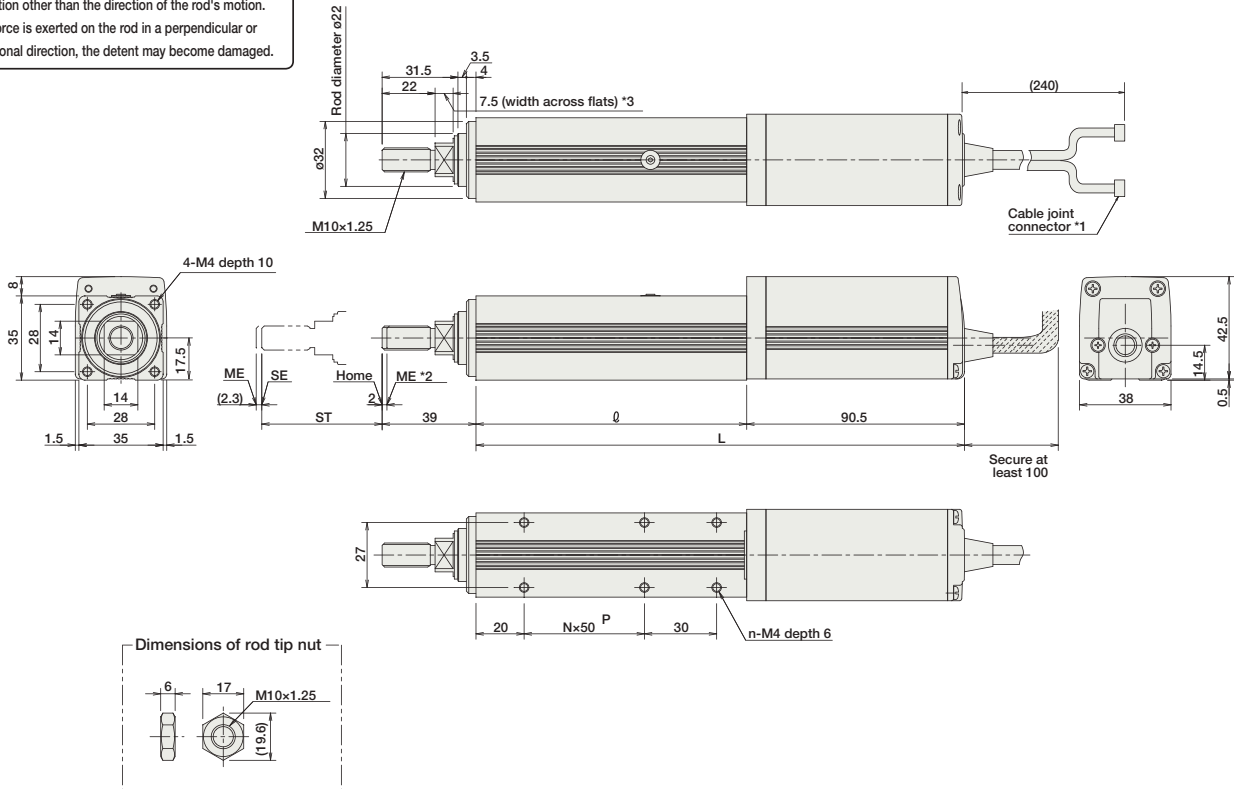

■ Dimensions/Weight by Stroke

Stroke	50	100	150	200
R	112.5	162.5	212.5	262.5
L	203	253	303	353
N	1	2	3	4
n	6	8	10	12
Weight (kg)	0.8	0.95	1.1	1.25

Compatible Controllers

The RCP2 series actuators can operate with the controllers below. Select the controller according to your usage.

Name	External View	Model	Description	Max. Positioning Points	Input Voltage	Power Supply Capacity	See Page
Solenoid Valve Type		PMEC-C-28SPI-NP-2-2	Easy-to-use controller, even for beginners	3 points	AC115V AC230V	See P481	→ P477
		PSEP-C-28SPI-NP-2-0	Operable with same signal as solenoid valve. Supports both single and double solenoid types. No homing necessary with simple absolute type.				
Splash-Proof Solenoid Valve Type		PSEP-CW-28SPI-NP-2-0					
Positioner Type		PCON-C-28SPI-NP-2-0	Positioning is possible for up to 512 points	512 points	DC24V	2A max.	
Safety-Compliant Positioner Type		PCON-CG-28SPI-NP-2-0					
Pulse Train Input Type (Differential Line Driver)		PCON-PL-28SPI-NP-2-0	Pulse train input type with differential line driver support	(-)	DC24V	2A max.	→ P525
Pulse Train Input Type (Open Collector)		PCON-PO-28SPI-NP-2-0	Pulse train input type with open collector support				
Serial Communication Type		PCON-SE-28SPI-N-0-0	Dedicated to serial communication	64 points			
Field Network Type		RPCON-28SP	Dedicated to field network	768 points			→ P503
Program Control Type		PSEL-C-1-28SPI-NP-2-0	Programmed operation is possible. Operation is possible on up to 2 axes	1500 points			→ P557

* This is for the single-axis PSEL.

- Slider Type
- Mini
- Standard
- Controllers Integrated
- Rod Type
- Mini
- Standard
- Controllers Integrated
- Table/Arm /Flat Type
- Mini
- Standard
- Gripper/ Rotary Type
- Linear Motor Type
- Cleanroom Type
- Splash Proof
- Controllers
- PMEC /AMEC
- PSEP /ASEP
- ROBO NET
- ERC2
- PCON
- ACON
- SCON
- PSEL
- ASEL
- SSEL
- XSEL
- Pulse Motor
- Servo Motor (24V)
- Servo Motor (230V)
- Linear Motor

- Slider Type
- Mini
- Standard
- Controllers Integrated
- Rod Type
- Mini
- Standard
- Controllers Integrated
- Table/Arm /Flat Type
- Mini
- Standard
- Gripper/ Rotary Type
- Linear Motor Type
- Cleanroom Type
- Splash Proof
- Controllers
- PMEC /AMEC
- PSEP /ASEP
- ROBO NET
- ERC2
- PCON
- ACON
- SCON
- PSEL
- ASEL
- SSEL
- XSEL
- Pulse Motor
- Servo Motor (24V)
- Servo Motor (230V)
- Linear Motor

RCP2-RA4C RoboCylinder Rod Type 45mm Width Pulse Motor Straight Type

■ Configuration: **RCP2** — **RA4C** — **I** — **42P** — — — — —

Series	Type	Encoder	Motor	Lead	Stroke	Compatible Controllers	Cable Length	Option
		I: Incremental * The Simple absolute encoder is also considered type "I".	42P: Pulse motor 42 □ size	10 : 10mm 5 : 5mm 2.5 : 2.5mm	50: 50mm 300: 300mm (50mm pitch increments)	P1: PCON RPCON PSEL P3: PMEAC PSEP	N : None P : 1m S : 3m M : 5m X □ □ : Custom R □ □ : Robot cable	B : Brake FL : Flange FT : Foot bracket NM: Reversed-home

* See page Pre-35 for an explanation of the naming convention.

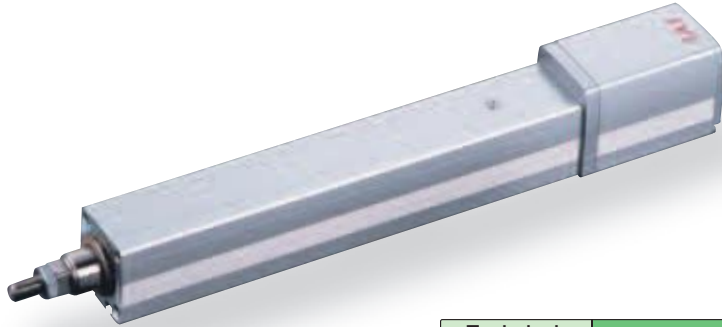

Technical References P. A-5

- POINT** Notes on Selection
- When the stroke increases, the maximum speed will drop to prevent the ball screw from reaching the critical rotational speed. Use the actuator specification table below to check the maximum speed at the stroke you desire.
 - Since the RCP2 series use a pulse motor, the load capacity decreases at high speeds. Check in the Speed vs. Load Capacity graph to see if your desired speed and load capacity are supported.
 - The load capacity is based on operation at an acceleration of 0.2G. In addition, the horizontal load capacity is based on the use of an external guide. If an external force is exerted on the rod from a direction other than the motion of the rod, the detent may become damaged.

■ Speed vs. Load Capacity
Due to the characteristics of the pulse motor, the RCP2 series' load capacity decreases at high speeds. In the table below, check if your desired speed and load capacity are supported.

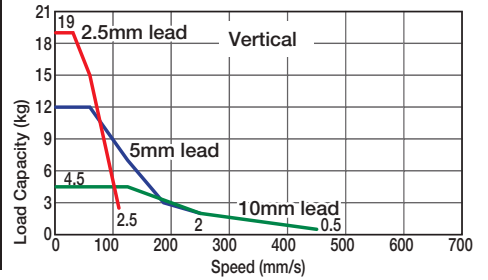
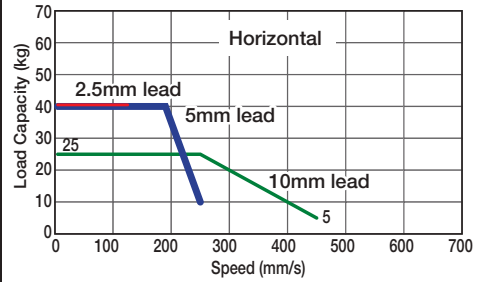

Actuator Specifications

Lead and Load Capacity

(Note 1) Please note that the maximum load capacity decreases as the speed increases.

Model	Lead (mm)	Max. Load Capacity (Note 1)		Maximum Push Force (N)(Note 2)	Stroke (mm)
		Horizontal (kg)	Vertical (kg)		
RCP2-RA4C-I-42P-10-①-②-③-④	10	~ 25	~ 4.5	150	50 ~ 300 (50mm increments)
RCP2-RA4C-I-42P-5-①-②-③-④	5	~ 40	~ 12	284	
RCP2-RA4C-I-42P-2.5-①-②-③-④	2.5	40	~ 19	358	

Legend: ① Stroke ② Compatible controller ③ Cable length ④ Options

(Note 2) See page A-69 for the pushing force graphs.

Stroke and Maximum Speed

Stroke / Lead	50 ~ 200 (50mm increments)	250 (mm)	300 (mm)
	10	458	458
5	250	237	175
2.5	125 <114>	118 <114>	87

* The values enclosed in < > apply for vertical usage. (Unit: mm/s)

Cable List

Type	Cable Symbol
Standard	P (1m)
	S (3m)
	M (5m)
Special Lengths	X06 (6m) ~ X10 (10m)
	X11 (11m) ~ X15 (15m)
	X16 (16m) ~ X20 (20m)
Robot Cable	R01 (1m) ~ R03 (3m)
	R04 (4m) ~ R05 (5m)
	R06 (6m) ~ R10 (10m)
	R11 (11m) ~ R15 (15m)
	R16 (16m) ~ R20 (20m)

* See page A-39 for cables for maintenance.

Option List

Name	Option Code	See Page
Brake	B	→ A-25
Flange	FL	→ A-27
Foot bracket	FT	→ A-29
Reversed-home	NM	→ A-33

Actuator Specifications

Item	Description
Drive System	Ball screw ø8mm C10 grade
Positioning Repeatability	±0.02mm
Lost Motion	0.1mm or less
Rod Diameter	ø22mm
Non-rotating accuracy of rod	±1.5 deg
Ambient Operating Temp./Humidity	0 ~ 40°C, 85% RH or less (non-condensing)

Dimensions

CAD drawings can be downloaded from IAI website. www.robocylinder.de



Note:
Do not apply any external force on the rod from any direction other than the direction of the rod's motion. If a force is exerted on the rod in a perpendicular or rotational direction, the detent may become damaged.

For Special Orders P. A-9

- *1. The motor-encoder cable is connected here. See page A-39 for details on cables.
- *2. When homing, the rod moves to the M.E.; therefore, please watch for any interference with the surrounding objects.
ME: Mechanical end
SE: Stroke end
The values enclosed in "()" are reference dimensions.
- *3. Please note that there is no T-slot on the base of the brake unit.
- *4. The orientation of the bolt will vary depending on the product.

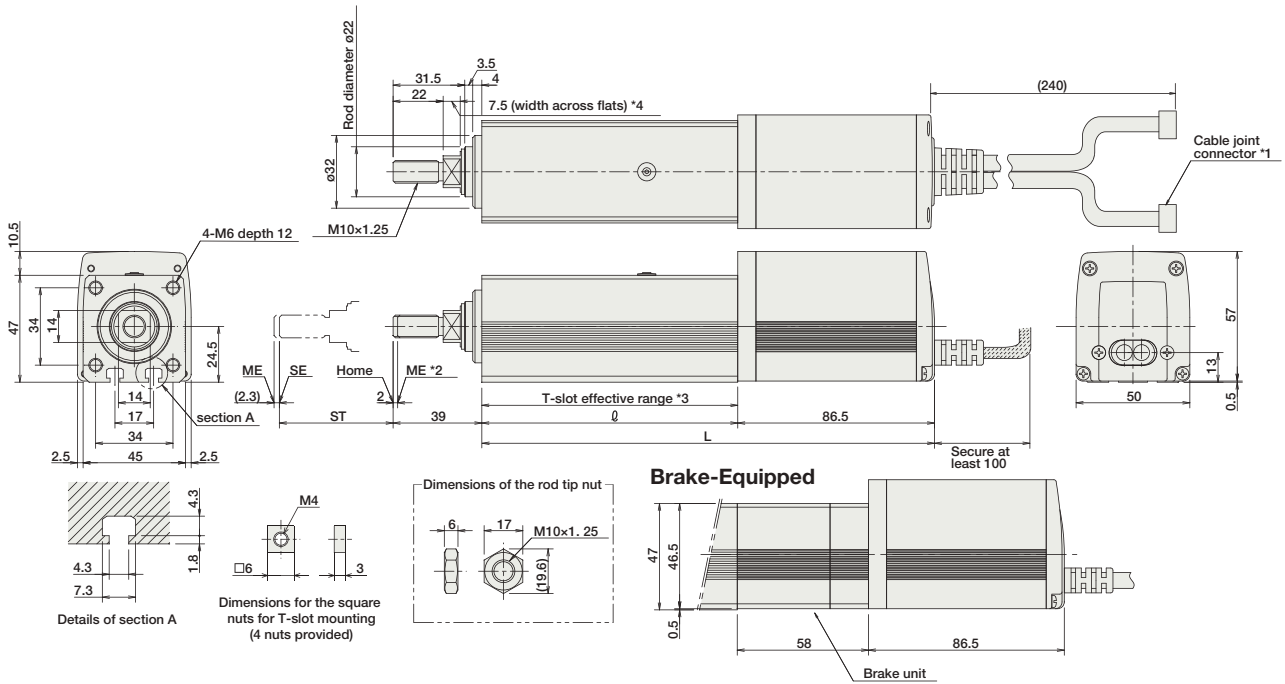

* Compared to the standard model, the brake-equipped model is longer by 58mm and heavier by 0.4kg.

■ Dimensions/Weight by Stroke

Stroke	50	100	150	200	250	300
R	112.5	162.5	212.5	262.5	312.5	362.5
L	199	249	299	349	399	449
Weight (kg)	1.35	1.6	1.85	2.1	2.35	2.6

Compatible Controllers

The RCP2 series actuators can operate with the controllers below. Select the controller according to your usage.

Name	External View	Model	Description	Max. Positioning Points	Input Voltage	Power Supply Capacity	See Page
Solenoid Valve Type		PMEC-C-42PI-NP-2-2	Easy-to-use controller, even for beginners	3 points	AC115V AC230V	See P481	→ P477
		PSEP-C-42PI-NP-2-0	Operable with same signal as solenoid valve. Supports both single and double solenoid types. No homing necessary with simple absolute type.				→ P487
Splash-Proof Solenoid Valve Type		PSEP-CW-42PI-NP-2-0					
Positioner Type		PCON-C-42PI-NP-2-0	Positioning is possible for up to 512 points	512 points	DC24V	2A max.	
Safety-Compliant Positioner Type		PCON-CG-42PI-NP-2-0					
Pulse Train Input Type (Differential Line Driver)		PCON-PL-42PI-NP-2-0	Pulse train input type with differential line driver support	(-)	DC24V	2A max.	→ P525
Pulse Train Input Type (Open Collector)		PCON-PO-42PI-NP-2-0	Pulse train input type with open collector support				
Serial Communication Type		PCON-SE-42PI-N-0-0	Dedicated to serial communication	64 points			
Field Network Type		RPCON-42P	Dedicated to field network	768 points			→ P503
Program Control Type		PSEL-C-1-42PI-NP-2-0	Programmed operation is possible. Operation is possible on up to 2 axes	1500 points			→ P557

* This is for the single-axis PSEL.

- Slider Type
- Mini
- Standard
- Controllers Integrated
- Rod Type
- Mini
- Standard
- Controllers Integrated
- Table/Arm /Flat Type
- Mini
- Standard
- Gripper/ Rotary Type
- Linear Motor Type
- Cleanroom Type
- Splash Proof
- Controllers
- PMEC /AMEC
- PSEP /ASEP
- ROBO NET
- ERC2
- PCON
- ACON
- SCON
- PSEL
- ASEL
- SSEL
- XSEL
- Pulse Motor
- Servo Motor (24V)
- Servo Motor (230V)
- Linear Motor

- Slider Type
- Mini
- Standard
- Controllers Integrated
- Rod Type
- Mini
- Standard
- Controllers Integrated
- Table/Arm /Flat Type
- Mini
- Standard
- Gripper/ Rotary Type
- Linear Motor Type
- Cleanroom Type
- Splash Proof
- Controllers
- PMEC /AMEC
- PSEP /ASEP
- ROBO NET
- ERC2
- PCON
- ACON
- SCON
- PSEL
- ASEL
- SSEL
- XSEL
- Pulse Motor
- Servo Motor (24V)
- Servo Motor (230V)
- Linear Motor

RCP2-RA6C RoboCylinder Rod Type 64mm Width Pulse Motor Straight Type

■ Configuration: **RCP2** — **RA6C** — **I** — **56P** — — — — —

Series	Type	Encoder	Motor	Lead	Stroke	Compatible Controllers	Cable Length	Option
		I: Incremental * The Simple absolute encoder is also considered type "I".	56P: Pulse motor 56 □ size	16 : 16mm 8 : 8mm 4 : 4mm	50: 50mm 300: 300mm (50mm pitch increments)	P1: PCON RPCON PSEL P3: PMECC PSEP	N : None P : 1m S : 3m M : 5m X □ □ : Custom R □ □ : Robot cable	B : Brake FL : Flange FT : Foot bracket NM: Reversed-home

* See page Pre-35 for an explanation of the naming convention.

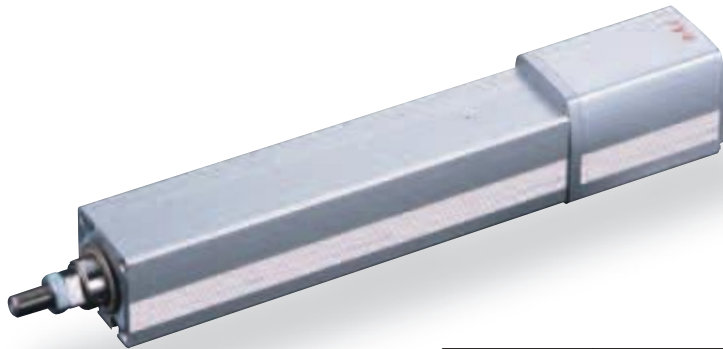

Technical References P. A-5

- POINT** Notes on Selection
- When the stroke increases, the maximum speed will drop to prevent the ball screw from reaching the critical rotational speed. Use the actuator specification table below to check the maximum speed at the stroke you desire.
 - Since the RCP2 series use a pulse motor, the load capacity decreases at high speeds. Check in the Speed vs. Load Capacity graph to see if your desired speed and load capacity are supported.
 - The load capacity is based on operation at an acceleration of 0.2G. In addition, the horizontal load capacity is based on the use of an external guide. If an external force is exerted on the rod from a direction other than the motion of the rod, the detent may become damaged.

■ Speed vs. Load Capacity
Due to the characteristics of the pulse motor, the RCP2 series' load capacity decreases at high speeds. In the table below, check if your desired speed and load capacity are supported.

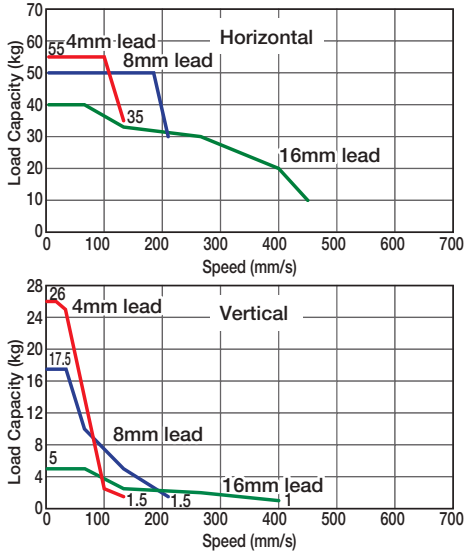

Actuator Specifications					
Lead and Load Capacity			Stroke and Maximum Speed		
Model	Lead (mm)	Max. Load Capacity (Note 1)		Maximum Push Force (N)(Note 2)	Stroke (mm)
		Horizontal (kg)	Vertical (kg)		
RCP2-RA6C-I-56P-16-①-②-③-④	16	~ 40	~ 5	240	50 ~ 300 (50mm increments)
RCP2-RA6C-I-56P-8-①-②-③-④	8	~ 50	~ 17.5	470	
RCP2-RA6C-I-56P-4-①-②-③-④	4	~ 55	~ 26	800	

Legend: ① Stroke ② Compatible controller ③ Cable length ④ Options (Note 2) See page A-69 for the pushing force graphs. * The values enclosed in < > apply for vertical usage. (Unit: mm/s)

Type	Cable Symbol
Standard	P (1m)
	S (3m)
	M (5m)
Special Lengths	X06 (6m) ~ X10 (10m)
	X11 (11m) ~ X15 (15m)
	X16 (16m) ~ X20 (20m)
Robot Cable	R01 (1m) ~ R03 (3m)
	R04 (4m) ~ R05 (5m)
	R06 (6m) ~ R10 (10m)
	R11 (11m) ~ R15 (15m)
	R16 (16m) ~ R20 (20m)

* See page A-39 for cables for maintenance.

Item	Description
Drive System	Ball screw ø12mm C10 grade
Positioning Repeatability	±0.02mm
Lost Motion	0.1mm or less
Rod Diameter	ø30mm
Non-rotating accuracy of rod	±1.0 deg
Ambient Operating Temp./Humidity	0 ~ 40°C, 85% RH or less (non-condensing)

Name	Option Code	See Page
Brake	B	→ A-25
Flange	FL	→ A-27
Foot bracket	FT	→ A-29
Reversed-home	NM	→ A-33

Dimensions

CAD drawings can be downloaded from IAI website. www.robocylinder.de



For Special Orders P. A-9

Note:
Do not apply any external force on the rod from any direction other than the direction of the rod's motion. If a force is exerted on the rod in a perpendicular or rotational direction, the detent may become damaged.

- *1. The motor-encoder cable is connected here. See page A-39 for details on cables.
- *2. When homing, the rod moves to the M.E.; therefore, please watch for any interference with the surrounding objects.
ME: Mechanical end
SE: Stroke end
The values enclosed in " () " are reference dimensions.
- *3. Please note that there is no T-slot on the base of the brake unit.
- *4. The orientation of the bolt will vary depending on the product.

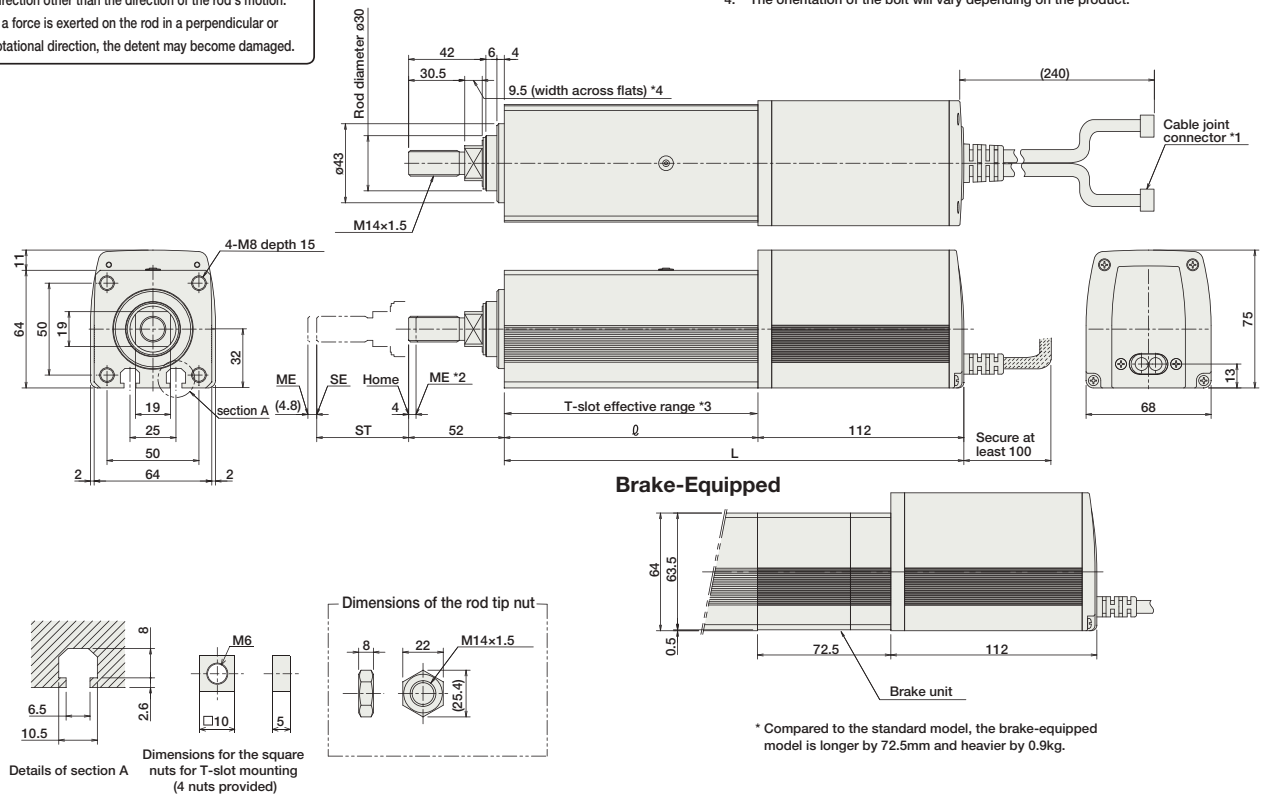

* Compared to the standard model, the brake-equipped model is longer by 72.5mm and heavier by 0.9kg.

■ Dimensions/Weight by Stroke

Stroke	50	100	150	200	250	300
ℓ	138	188	238	288	338	388
L	250	300	350	400	450	500
Weight (kg)	3.1	3.6	4.1	4.6	5.1	5.6

Compatible Controllers

The RCP2 series actuators can operate with the controllers below. Select the controller according to your usage.

Name	External View	Model	Description	Max. Positioning Points	Input Voltage	Power Supply Capacity	See Page
Solenoid Valve Type		PMEC-C-56PI-NP-2-2	Easy-to-use controller, even for beginners	3 points	AC115V AC230V	See P481	→ P477
		PSEP-C-56PI-NP-2-0	Operable with same signal as solenoid valve. Supports both single and double solenoid types. No homing necessary with simple absolute type.				
Splash-Proof Solenoid Valve Type		PSEP-CW-56PI-NP-2-0					
Positioner Type		PCON-C-56PI-NP-2-0	Positioning is possible for up to 512 points	512 points	DC24V	2A max.	
Safety-Compliant Positioner Type		PCON-CG-56PI-NP-2-0					
Pulse Train Input Type (Differential Line Driver)		PCON-PL-56PI-NP-2-0	Pulse train input type with differential line driver support	(-)	DC24V	2A max.	→ P525
Pulse Train Input Type (Open Collector)		PCON-PO-56PI-NP-2-0	Pulse train input type with open collector support				
Serial Communication Type		PCON-SE-56PI-N-0-0	Dedicated to serial communication	64 points			
Field Network Type		RPCON-56P	Dedicated to field network	768 points			→ P503
Program Control Type		PSEL-C-1-56PI-NP-2-0	Programmed operation is possible. Operation is possible on up to 2 axes	1500 points			→ P557

* This is for the single-axis PSEL.

- Slider Type
- Mini
- Standard
- Controllers Integrated
- Rod Type
- Mini
- Standard
- Controllers Integrated
- Table/Arm /Flat Type
- Mini
- Standard
- Gripper/ Rotary Type
- Linear Motor Type
- Cleanroom Type
- Splash Proof
- Controllers
- PMEC /AMEC
- PSEP /ASEP
- ROBO NET
- ERC2
- PCON
- ACON
- SCON
- PSEL
- ASEL
- SSEL
- XSEL
- Pulse Motor
- Servo Motor (24V)
- Servo Motor (230V)
- Linear Motor

- Slider Type
- Mini
- Standard
- Controllers Integrated
- Rod Type
- Mini
- Standard
- Controllers Integrated
- Table/Arm /Flat Type
- Mini
- Standard
- Gripper/ Rotary Type
- Linear Motor Type
- Cleanroom Type
- Splash Proof
- Controllers
- PMEC /AMEC
- PSEP /ASEP
- ROBO NET
- ERC2
- PCON
- ACON
- SCON
- PSEL
- ASEL
- SSEL
- XSEL
- Pulse Motor
- Servo Motor (24V)
- Servo Motor (230V)
- Linear Motor

RCP2-RA8C RoboCylinder Rod Type 85mm Width Pulse Motor Straight Type

■ Configuration: **RCP2** — **RA8C** — **I** — **60P** — — — **P2** — —

Series — Type — Encoder — Motor — Lead — Stroke — Compatible Controllers — Cable Length — Option

I: Incremental
* The Simple absolute encoder is also considered type "I".

60P: Pulse motor
60 □ size

10 : 10mm
5 : 5mm

50: 50mm
300: 300mm (50mm pitch increments)

P2: PCON-CF

N : None
P : 1m
S : 3m
M : 5m
X □ □ : Custom
R □ □ : Robot cable

See Options below

* See page Pre-35 for an explanation of the naming convention.



Technical References P. A-5

- POINT**
Notes on Selection
- When the stroke increases, the maximum speed will drop to prevent the ball screw from reaching the critical rotational speed. Use the actuator specification table below to check the maximum speed at the stroke you desire.
 - Since the RCP2 series use a pulse motor, the load capacity decreases at high speeds. Check in the Speed vs. Load Capacity graph to see if your desired speed and load capacity are supported.
 - The load capacity is based on operation at an acceleration of 0.2G for 10mm-lead and 0.1G for 5mm-lead. This is the upper limit of the acceleration. In addition, the horizontal load capacity is based on the use of an external guide. If an external force is exerted on the rod from a direction other than the motion of the rod, the detent may become damaged.

■ Speed vs. Load Capacity
Due to the characteristics of the pulse motor, the RCP2 series' load capacity decreases at high speeds. In the table below, check if your

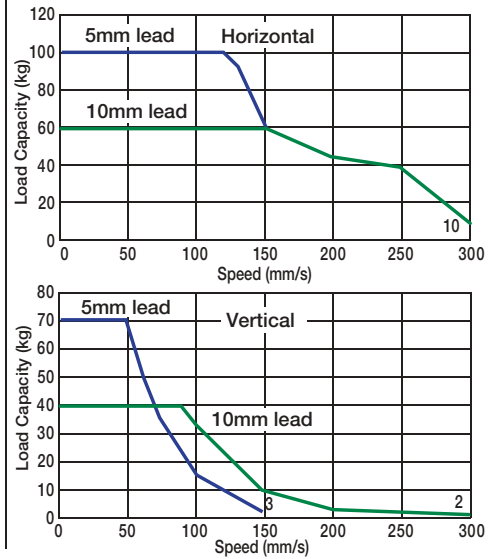

Actuator Specifications

■ Lead and Load Capacity (Note 1) Please note that the maximum load capacity decreases as the speed increases.

Model	Lead (mm)	Max. Load Capacity (Note 1)		Maximum Push Force (N)(Note 2)	Stroke (mm)
		Horizontal (kg)	Vertical (kg)		
RCP2-RA8C-I-60P-10-① - P2 - ② - ③	10	60	40	857	50 ~ 300 (50mm increments)
RCP2-RA8C-I-60P-5-① - P2 - ③ - ③	5	100	70	1714	

■ Stroke and Maximum Speed

Lead	Stroke	50 ~ 300 (50mm increments)
		10
5	150	

Legend: ① Stroke ② Compatible controller ③ Cable length ④ Options

(Note 2) See page A-70 for the pushing force graphs.

(Unit: mm/s)

Cable List

Type	Cable Symbol
Standard	P (1m)
	S (3m)
	M (5m)
Special Lengths	X06 (6m) ~ X10 (10m)
	X11 (11m) ~ X15 (15m)
	X16 (16m) ~ X20 (20m)
Robot Cable	R01 (1m) ~ R03 (3m)
	R04 (4m) ~ R05 (5m)
	R06 (6m) ~ R10 (10m)
	R11 (11m) ~ R15 (15m)
	R16 (16m) ~ R20 (20m)

* See page A-39 for cables for maintenance.

Option List

Name	Option Code	See Page
Brake	B	→ A-25
Flange	FL	→ A-27
Foot bracket	FT	→ A-29
Reversed-home	NM	→ A-33
Cable exit direction	A1 - A3	→ A-25

Actuator Specifications

Item	Description
Drive System	Ball screw ø16mm C10 grade
Positioning Repeatability	±0.02mm
Lost Motion	0.1mm or less
Rod Diameter	ø40mm
Non-rotating accuracy of rod	±1.0 deg
Ambient Operating Temp./Humidity	0 ~ 40°C, 85% RH or less (non-condensing)
Service Life	5000km (*1)

(*1) See page 146-2 for vertical payload graphs.

- Slider Type
- Mini
- Standard
- Controllers Integrated
- Rod Type
- Mini
- Standard
- Controllers Integrated
- Table/Arm /Flat Type
- Mini
- Standard
- Gripper/ Rotary Type
- Linear Motor Type
- Cleanroom Type
- Splash Proof
- Controllers
- PMEC /AMEC
- PSEP /ASEP
- ROBO NET
- ERC2
- PCON
- ACON
- SCON
- PSEL
- ASEL
- SSEL
- XSEL
- Pulse Motor
- Servo Motor (24V)
- Servo Motor (230V)
- Linear Motor

Dimensions

CAD drawings can be downloaded from IAI website. www.robocylinder.de

For Special Orders P. A-9

2/3D CAD

Note:
Do not apply any external force on the rod from any direction other than the direction of the rod's motion. If a force is exerted on the rod in a perpendicular or rotational direction, the detent may become damaged.

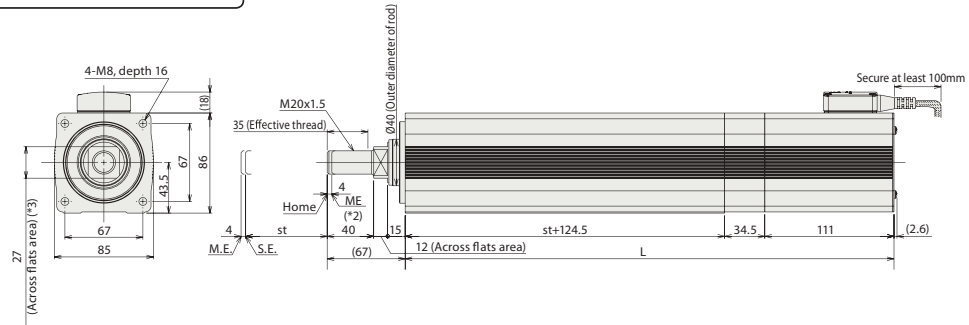
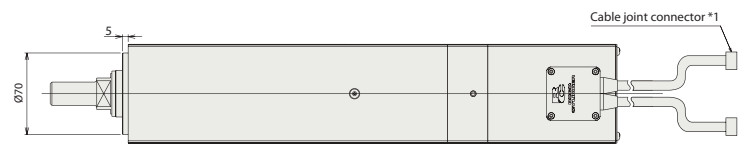

Dimensions of flange type

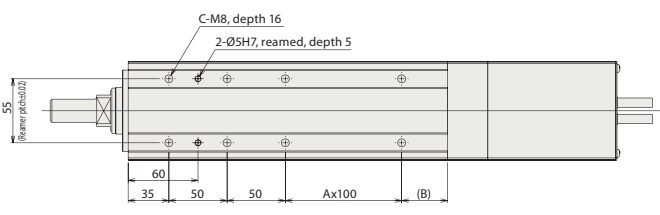
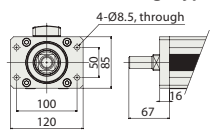

Dimensions of foot bracket type

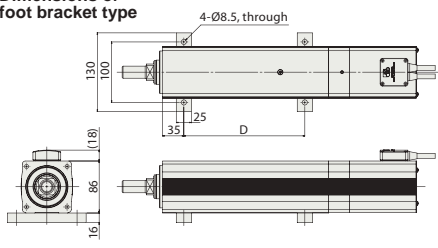

Dimensions of brake type

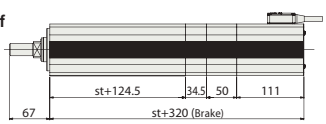

- *1. The motor-encoder cable is connected here. Please note that although the motor cable is the same as RCP2 series, the encoder cable is series-specific. See page A-39 for details on cables.
- *2. When homing, the rod moves to the ME; therefore, please watch for any interference with the surrounding objects.
ME: Mechanical end
SE: Stroke end
The values enclosed in "()" are reference dimensions.
- *3. The direction of two sides defining the across flat area varies depending on the product.

■ Dimensions/Weight by Stroke

Stroke	50	100	150	200	250	300
L	320	370	420	470	520	570
A	0	0	1	1	2	2
B	39.5	89.5	39.5	89.5	39.5	89.5
C	6	6	8	8	10	10
D	100	100	200	200	300	300
Weight (kg)	No brake	6.5	7.4	8.2	9.1	10.7
	Brake-equipped	7.5	8.4	9.2	10.1	11.7

Vertical Payload and Service Life

● Rod-type RoboCylinder actuators have a service life of 5000km, but the RCP2-RA8C/RA8R types with a lead of 5 may have a shorter service life depending on the transferring mass because the applicable thrust is higher. Check the relationship of load capacity and service life for your actuator on the graph shown to the right.

Note:
The rated value is the maximum value that can meet a service life of 5000km. The maximum value is the value at which it is still operable. Please note that operation with values exceeding the rated value will result in a decrease in the service life, as shown in the graphs.

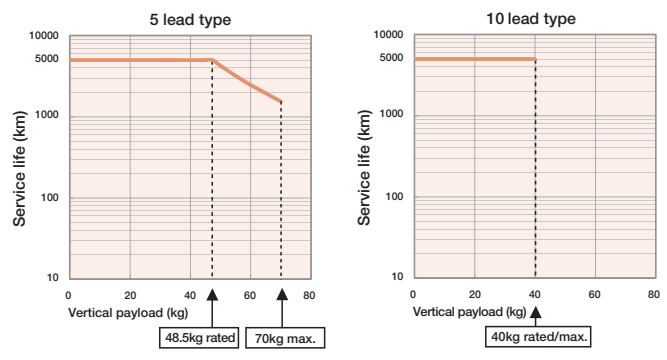

Compatible Controllers

The controller for the RCP2-RA8C type is the following dedicated controller.

Name	External View	Model	Description	Max. Positioning Points	Input Voltage	Power Supply Capacity	See Page
Positioner Type		PCON-CF-60PI-NP-2-0	Positioning is possible for up to 512 points	512 points	DC24V	6A max.	→ P525

Note:

- Please note that the encoder cable is a dedicated cable for the CF model, which is different from the PCON-C/CG/CY/PL/PO/SE controllers.
- The simple absolute unit cannot be used.

RCP2-RA10C

RoboCylinder Rod Type 100mm Width Pulse Motor Straight Type

■ Configuration: **RCP2** -- **RA10C** -- **I** -- **86P** -- -- -- **P2** -- --

Series	Type	Encoder	Motor	Lead	Stroke	Compatible Controllers	Cable Length	Option
I: Incremental			86P: Pulse motor 86 □ size	10 : 10mm 5 : 5mm 2.5 : 2.5mm	50: 50mm 300: 300mm (50mm pitch increments)	P2: PCON-CF	N : None P : 1m S : 3m M : 5m X □ □ : Custom R □ □ : Robot cable	A1-A3 : Connector cable exit direction B : Brake FL : Flange FT : Foot bracket

* See page Pre-35 for an explanation of the naming convention.

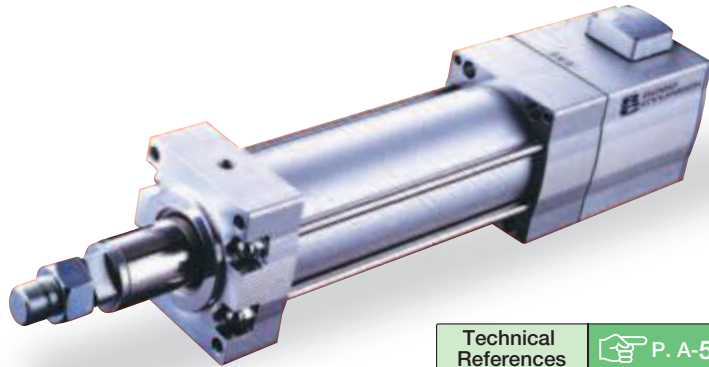

Technical References P. A-5

- POINT**
Notes on Selection
- (1) Minimum speed is set per each lead. (10mm-lead: 10mm/s, 5mm-lead: 5mm/s, 2.5-lead: 1mm/s) Please note that if the actuator is operated below the minimum speed, vibration may occur.
 - (2) Since the RCP2 series use a pulse motor, the load capacity decreases at high speeds. Check in the Speed vs. Load Capacity graph to see if your desired speed and load capacity are supported.
 - (3) The load capacity is based on operation at an acceleration of 0.04G for 10mm-lead, 0.02G for 5mm-lead, and 0.01G for 2.5mm-lead. This is the upper limit of the acceleration. In addition, the horizontal load capacity is based on the use of an external guide. If an external force is exerted on the rod from a direction other than the motion of the rod, the detent may become damaged.

■ Speed vs. Load Capacity
Due to the characteristics of the pulse motor, the RCP2 series' load capacity decreases at high speeds. In the table below, check if your desired speed and load capacity are supported.

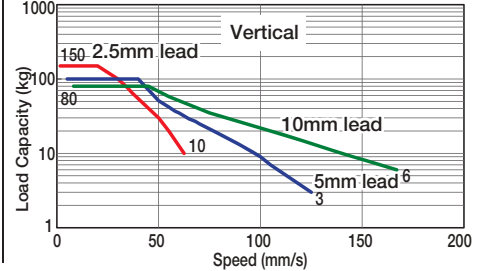
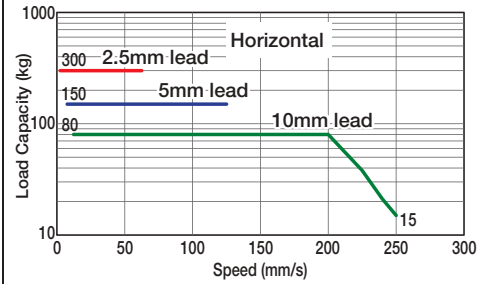

Actuator Specifications

■ Lead and Load Capacity

(Note 1) Please note that the maximum load capacity decreases as the speed increases.

Model	Lead (mm)	Max. Load Capacity (Note 1)		Maximum Push Force (N)(Note 2)	Stroke (mm)
		Horizontal (kg)	Vertical (kg)		
RCP2-RA10C-I-86P-10-①-P2-②-③	10	~ 80	~ 80	1500	50 ~ 300 (50mm increments)
RCP2-RA10C-I-86P-5-①-P2-②-③	5	150	~ 100	3000	
RCP2-RA10C-I-86P-2.5-①-P2-②-③	2.5	300	~ 150	6000	

Legend ① Stroke ② Cable length ③ Options

(Note 2) See page A-70 for the pushing force graphs.

■ Stroke and Maximum Speed

Lead	Stroke	50 ~ 300 (50mm increments)
		10
5		125
2.5		63

* The values enclosed in < > apply for vertical usage. (Unit: mm/s)

Cable List

Type	Cable Symbol
Standard	P (1m)
	S (3m)
	M (5m)
Special Lengths	X06 (6m) ~ X10 (10m)
	X11 (11m) ~ X15 (15m)
	X16 (16m) ~ X20 (20m)
Robot Cable	R01 (1m) ~ R03 (3m)
	R04 (4m) ~ R05 (5m)
	R06 (6m) ~ R10 (10m)
	R11 (11m) ~ R15 (15m)
	R16 (16m) ~ R20 (20m)

* See page A-39 for cables for maintenance.

Option List

Name	Option Code	See Page
Connector cable exit direction	A1 ~ A3	→ A-25
Brake	B	→ A-25
Flange	FL	→ A-27
Foot bracket	FT	→ A-29

Actuator Specifications

Item	Description
Drive System	Ball screw C10 grade
Positioning Repeatability	±0.02mm
Lost Motion	0.1mm or less
Rod Diameter	ø40mm
Non-rotating accuracy of rod	±1.0 deg
Ambient Operating Temp./Humidity	0 ~ 40°C, 85% RH or less (non-condensing)

Dimensions

CAD drawings can be downloaded from IAI website. www.robocylinder.de

For Special Orders P. A-9

2/3D CAD

* The RA10C is not available in reversed-home configuration, due to its construction.

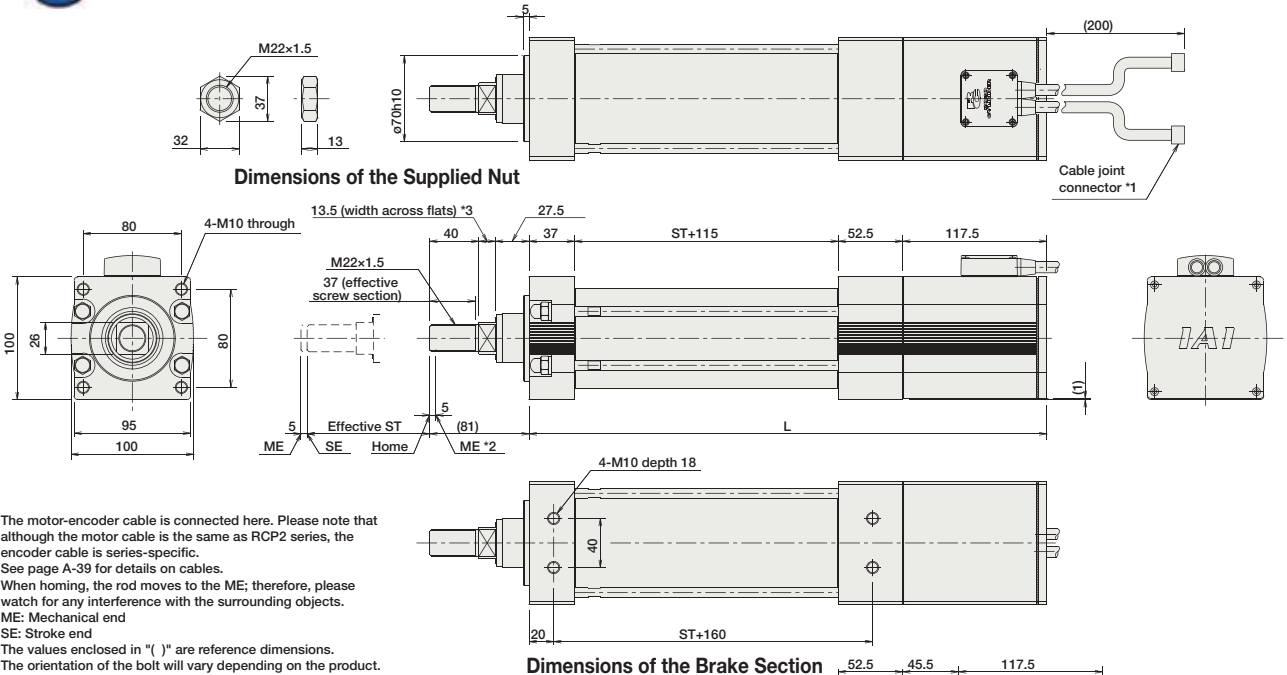

- *1. The motor-encoder cable is connected here. Please note that although the motor cable is the same as RCP2 series, the encoder cable is series-specific. See page A-39 for details on cables.
- *2. When homing, the rod moves to the ME; therefore, please watch for any interference with the surrounding objects.
ME: Mechanical end
SE: Stroke end
The values enclosed in "()" are reference dimensions.
- *3. The orientation of the bolt will vary depending on the product.

Note:
Do not apply any external force on the rod from any direction other than the direction of the rod's motion. If a force is exerted on the rod in a perpendicular or rotational direction, the detent may become damaged.

* Compared to the standard model, the brake-equipped model is longer by 45.5mm and heavier by 1.5kg.

■ Dimensions/Weight by Stroke

Stroke	50	100	150	200	250	300
L	372	422	472	522	572	622
Weight (kg)	9	9.5	10	10.5	11	11.5

Vertical Payload and Service Life

● The service life of a rod-type RoboCylinder is 5000km. However, since the RCP2-RA10C has a larger maximum thrust compared to other types, its service life will largely depend on the load capacity and pushing force used. Therefore, when selecting your product using the Speed vs. Load Capacity and Pushing Force vs. Current Limit graphs, check the service life using the Load Capacity vs. Service Life graph and Pushing Force vs. Service Life table.

Note:
The rated value is the maximum value that can meet a service life of 5000km. The maximum value is the value at which it is still operable. Please note that operation with values exceeding the rated value will result in a decrease in the service life, as shown in the graphs.

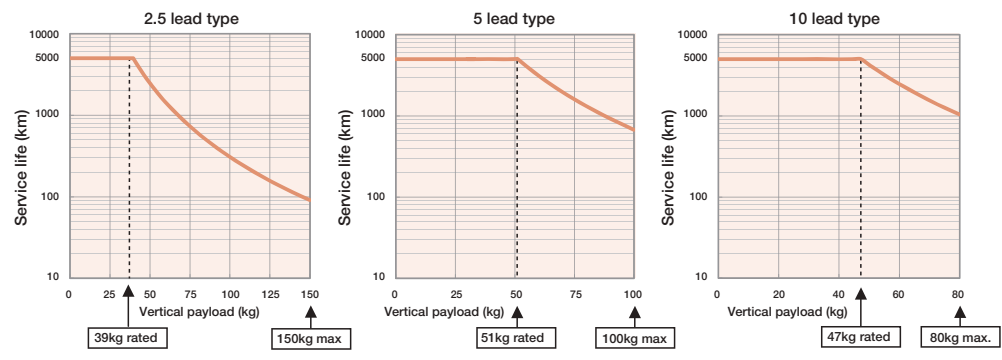

Compatible Controllers

The controller for the RCP2-RA10C type is the following dedicated controller.

Name	External View	Model	Description	Max. Positioning Points	Input Voltage	Power Supply Capacity	See Page
Positioner Type		PCON-CF-86PI-NP-2-0	Positioning is possible for up to 512 points	512 points	DC24V	6A max.	→ P525

- Note:**
- Please note that the encoder cable is a dedicated cable for the CF model, which is different from the PCON-C/CG/CY/PL/PO/SE controllers.
 - The simple absolute unit cannot be used.

- Slider Type
- Mini
- Standard
- Controllers Integrated
- Rod Type
- Mini
- Standard
- Controllers Integrated
- Table/Arm /Flat Type
- Mini
- Standard
- Gripper/ Rotary Type
- Linear Motor Type
- Cleanroom Type
- Splash Proof
- Controllers
- PMEC /AMEC
- PSEP /ASEP
- ROBO NET
- ERC2
- PCON
- ACON
- SCON
- PSEL
- ASEL
- SSEL
- XSEL
- Pulse Motor
- Servo Motor (24V)
- Servo Motor (230V)
- Linear Motor

RCP2-RA8R

RoboCylinder Rod Type 85mm Width Pulse Motor Side-Mounted Motor

■ Configuration: **RCP2** — **RA8R** — **I** — **60P** — — — **P2** — —

Series	Type	Encoder	Motor	Lead	Stroke	Compatible Controllers	Cable Length	Option
I: Incremental * The Simple absolute encoder is also considered type "I".	60P: Pulse motor 60 □ size	10 : 10mm 5 : 5mm	50: 50mm 300: 300mm (50mm pitch increments)	P2: PCON-CF	N : None P : 1m S : 3m M : 5m X □ : Custom R □ : Robot cable	See Options below		

* See page Pre-35 for an explanation of the naming convention.



Technical References P. A-5

- POINT** Notes on Selection
- When the stroke increases, the maximum speed will drop to prevent the ball screw from reaching the critical rotational speed. Use the actuator specification table below to check the maximum speed at the stroke you desire.
 - Since the RCP2 series use a pulse motor, the load capacity decreases at high speeds. Check in the Speed vs. Load Capacity graph to see if your desired speed and load capacity are supported.
 - The load capacity is based on operation at an acceleration of 0.2G for 10mm-lead and 0.1G for 5mm-lead. This is the upper limit of the acceleration. In addition, the horizontal load capacity is based on the use of an external guide. If an external force is exerted on the rod from a direction other than the motion of the rod, the detent may become damaged.

■ Speed vs. Load Capacity
Due to the characteristics of the pulse motor, the RCP2 series' load capacity decreases at high speeds. In the table below, check if your

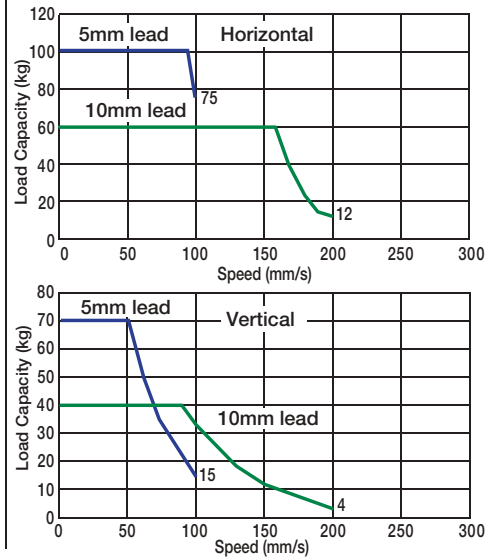

Actuator Specifications

■ Lead and Load Capacity

(Note 1) Please note that the maximum load capacity decreases as the speed increases.

Model	Lead (mm)	Max. Load Capacity (Note 1)		Maximum Push Force (N)(Note 2)	Stroke (mm)
		Horizontal (kg)	Vertical (kg)		
RCP2-RA8R-I-60P-10-① - P2 - ② - ③	10	60	40	857	50 ~ 300 (50mm increments)
RCP2-RA8R-I-60P-5-① - P2 - ③ - ③	5	100	70	1714	

Legend: ① Stroke ② Compatible controller ③ Cable length ④ Options

(Note 2) See page A-70 for the pushing force graphs.

■ Stroke and Maximum Speed

Lead	Stroke	50 ~ 300 (50mm increments)
		10
5	100	

(Unit: mm/s)

Cable List

Type	Cable Symbol
Standard	P (1m)
	S (3m)
	M (5m)
Special Lengths	X06 (6m) ~ X10 (10m)
	X11 (11m) ~ X15 (15m)
	X16 (16m) ~ X20 (20m)
Robot Cable	R01 (1m) ~ R03 (3m)
	R04 (4m) ~ R05 (5m)
	R06 (6m) ~ R10 (10m)
	R11 (11m) ~ R15 (15m)
	R16 (16m) ~ R20 (20m)

* See page A-39 for cables for maintenance.

Actuator Specifications

Item	Description
Drive System	Ball screw ø16mm C10 grade
Positioning Repeatability	±0.02mm
Lost Motion	0.1mm or less
Rod Diameter	ø40mm
Non-rotating accuracy of rod	±1.0 deg
Ambient Operating Temp./Humidity	0 ~ 40°C, 85% RH or less (non-condensing)
Service Life	5000km (*1)

(*1) See page 146-2 for vertical payload graphs.

Option List

Name	Option Code	See Page
Brake	B	→ A-25
Top-mounted motor	MT1/MT2/MT3	→ 148-2
Right-mounted motor	MR1/MR2	→ 148-2
Left-mounted motor	ML1/ML3	→ 148-2
Flange	FL	→ A-27
Foot bracket	FT	→ A-29
Reversed-home	NM	→ A-33
Cable exit direction	A1 ~ A3	→ A-25

RCP2-SRA4R

RoboCylinder Short-Length Rod Type 45mm Width Pulse Motor Side-Mounted Motor

■ Configuration: **RCP2** — **SRA4R** — **I** — **35P** — — — — —

Series — Type — Encoder — Motor — Lead — Stroke — Compatible Controllers — Cable Length — Option

I: Incremental * The Simple absolute encoder is also considered type "I".
 35P: Pulse motor 35 □ size
 5 : 5mm
 2.5 : 2.5mm
 20: 20mm
 200: 200mm (10mm pitch increments) * 50mm increments over 100 mm
 P1: PCON
 RCON
 PSEL
 P3: PMEC
 PSEP
 N : None
 P : 1m
 S : 3m
 M : 5m
 X □ □ : Custom
 See Options below

* See page Pre-35 for an explanation of the naming convention.



Technical References P. A-5

- POINT** Notes on Selection
- Since the RCP2 series use a pulse motor, the load capacity decreases at high speeds. Check in the Speed vs. Load Capacity graph to see if your desired speed and load capacity are supported.
 - The load capacity is based on operation at an acceleration of 0.3G (0.2G for the 2.5mm-lead model, or when used vertically). This is the upper limit of the acceleration.
 - The horizontal load capacity is based on the use of an external guide. If an external force is exerted on the rod from a direction other than the motion of the rod, the detent may become damaged.

■ Speed vs. Load Capacity
 Due to the characteristics of the pulse motor, the RCP2 series' load capacity decreases at high speeds. In the table below, check if your desired speed and load capacity are supported.

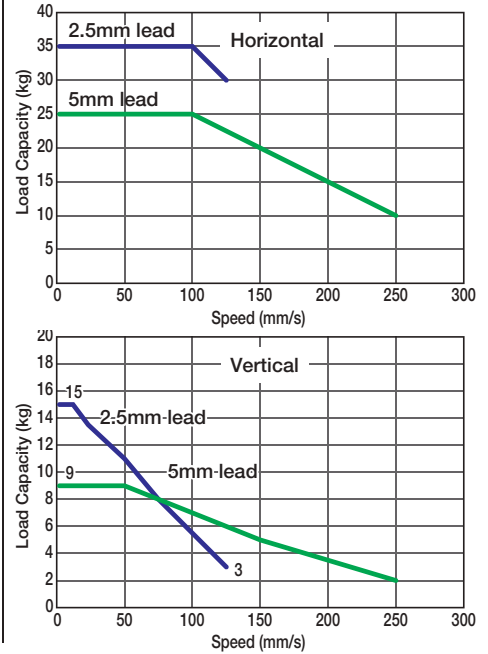

Actuator Specifications

■ Lead and Load Capacity

(Note 1) Please note that the maximum load capacity decreases as the speed increases.

Model	Lead (mm)	Max. Load Capacity (Note 1)		Maximum Push Force (N) (Note 2)	Stroke (mm)
		Horizontal (kg)	Vertical (kg)		
RCP2-SRA4R-I-35P-5-①-②-③-④	5	~ 25	~ 9	90	20 ~ 200 (10mm increments) (Note 3)
RCP2-SRA4R-I-35P-2.5-①-②-③-④	2.5	~ 35	~ 15	170	

Legend: ① Stroke ② Compatible controller ③ Cable length ④ Options

(Note 2) See page A-69 for the pushing force graphs.
 (Note 3) 50mm increments over 100mm.

(Unit: mm/s)

■ Stroke and Maximum Speed

Lead	Stroke	20 ~ 200 (10mm increments)
	5	250
2.5	125	

Cable List

Type	Cable Symbol
Standard (Robot Cables)	P (1m)
	S (3m)
	M (5m)
Special Lengths	X06 (6m) ~ X10 (10m)
	X11 (11m) ~ X15 (15m)
	X16 (16m) ~ X20 (20m)

* The cable is a motor-encoder integrated cable, and is provided as a robot cable.
 * See page A-39 for cables for maintenance.

Actuator Specifications

Item	Description
Drive System	Ball screw ø8mm C10 grade
Positioning Repeatability	±0.02mm
Lost Motion	0.1mm or less
Rod Diameter	ø22mm
Non-rotating accuracy of rod	-
Ambient Operating Temp./Humidity	0 ~ 40°C, 85% RH or less (non-condensing)

Option List

Name	Option Code	See Page
Brake	B	→ A-25
Flange bracket (front)	FL	→ A-27
Flange bracket (back)	FLR	→ A-28
Foot bracket 1 (base mounting)	FT	→ A-29
Foot bracket 2 (right/left side mounting)	FT2/FT4	→ A-31
Reversed-home	NM	→ A-33

* The brake is available for strokes of 70mm or more.

Dimensions

CAD drawings can be downloaded from IAI website. www.robocylinder.de

For Special Orders P. A-9

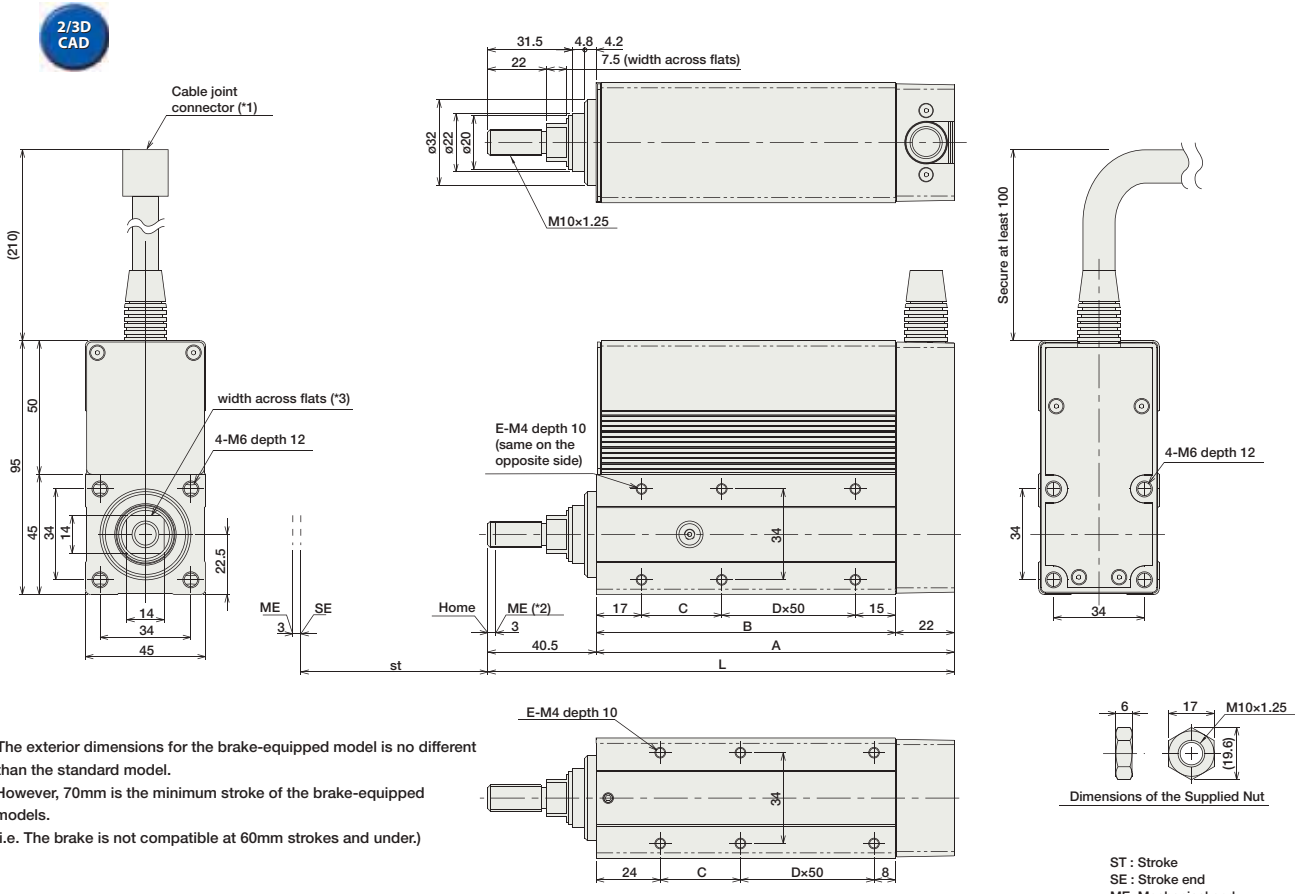

* The exterior dimensions for the brake-equipped model is no different than the standard model.
However, 70mm is the minimum stroke of the brake-equipped models.
(i.e. The brake is not compatible at 60mm strokes and under.)

■ Dimensions/Weight by Stroke (Add 0.2kg for brake equipped)

Stroke	20	30	40	50	60	70	80	90	100	150	200
L	124.5	134.5	144.5	154.5	164.5	174.5	184.5	194.5	204.5	254.5	304.5
A	84	94	104	114	124	134	144	154	164	214	264
B	62	72	82	92	102	112	122	132	142	192	242
C	30	40	50	60	70	80	90	100	110	160	210
D	0	0	0	0	0	1	1	1	1	2	3
E	4	4	4	4	4	6	6	6	6	8	10
Weight (kg)	0.83	0.89	0.96	1.02	1.08	1.14	1.21	1.27	1.33	1.64	1.95

- (*1) The motor-encoder cable is connected here. See page A-39 for details on cables.
- (*2) When homing, the rod moves to the mechanical end position; therefore, please watch for any interference with the surrounding objects.
- (*3) The orientation of the bolt will vary depending on the product.

Compatible Controllers

The RCP2 series actuators can operate with the controllers below. Select the controller according to your usage.

Name	External View	Model	Description	Max. Positioning Points	Input Voltage	Power Supply Capacity	See Page
Solenoid Valve Type		PMEC-C-35PI-NP-2-2	Easy-to-use controller, even for beginners	3 points	AC115V AC230V	See P481	→ P477
		PSEP-C-35PI-NP-2-0	Operable with same signal as solenoid valve. Supports both single and double solenoid types. No homing necessary with simple absolute type.				
Splash-Proof Solenoid Valve Type		PSEP-CW-35PI-NP-2-0					
Positioner Type		PCON-C-35PI-NP-2-0	Positioning is possible for up to 512 points	512 points	DC24V	2A max.	
Safety-Compliant Positioner Type		PCON-CG-35PI-NP-2-0					
Pulse Train Input Type (Differential Line Driver)		PCON-PL-35PI-NP-2-0	Pulse train input type with differential line driver support	(-)	DC24V	2A max.	→ P525
Pulse Train Input Type (Open Collector)		PCON-PO-35PI-NP-2-0	Pulse train input type with open collector support				
Serial Communication Type		PCON-SE-35PI-N-0-0	Dedicated to serial communication	64 points			
Field Network Type		RPCON-35P	Dedicated to field network	768 points			→ P503
Program Control Type		PSEL-C-1-35PI-NP-2-0	Programmed operation is possible. Operation is possible on up to 2 axes	1500 points			→ P557

* This is for the single-axis PSEL.

- Slider Type
- Mini
- Standard
- Controllers Integrated
- Rod Type
- Mini
- Standard
- Controllers Integrated
- Table/Arm /Flat Type
- Mini
- Standard
- Gripper/ Rotary Type
- Linear Motor Type
- Cleanroom Type
- Splash Proof
- Controllers
- PMEC /AMEC
- PSEP /ASEP
- ROBO NET
- ERC2
- PCON
- ACON
- SCON
- PSEL
- ASEL
- SSEL
- XSEL
- Pulse Motor
- Servo Motor (24V)
- Servo Motor (230V)
- Linear Motor

RCP2-RGS4C

RoboCylinder Rod Type with Single Guide 45mm Width Pulse Motor Straight Type

■ Configuration: **RCP2** - **RGS4C** - **I** - **42P** - [] - [] - [] - [] - []

Series	Type	Encoder	Motor	Lead	Stroke	Compatible Controllers	Cable Length	Option
		I: Incremental * The Simple absolute encoder is also considered type "I".	42P: Pulse motor 42 □ size	10 : 10mm 5 : 5mm 2.5 : 2.5mm	50: 50mm 300: 300mm (50mm pitch increments)	P1: PCON RPCON PSEL P3: PMEC PSEP	N : None P : 1m S : 3m M : 5m X □ : Custom R □ : Robot cable	B : Brake FT : Foot bracket NM: Reversed-home

* See page Pre-35 for an explanation of the naming convention.



Technical References P. A-5



- When the stroke increases, the maximum speed will drop to prevent the ball screw from reaching the critical rotational speed. Use the actuator specification table below to check the maximum speed at the stroke you desire.
- Since the RCP2 series use a pulse motor, the load capacity decreases at high speeds. Check in the Speed vs. Load Capacity graph to see if your desired speed and load capacity are supported.
- The load capacity is based on operation at an acceleration of 0.2G. 0.2G is the upper limit of the acceleration. In addition, the horizontal load capacity is based on the use of an external guide. See the technical resources (page A-82) for the allowable weight using the supplied guide alone.

■ Speed vs. Load Capacity
Due to the characteristics of the pulse motor, the RCP2 series' load capacity decreases at high speeds. In the table below, check if your desired speed and load capacity are supported.

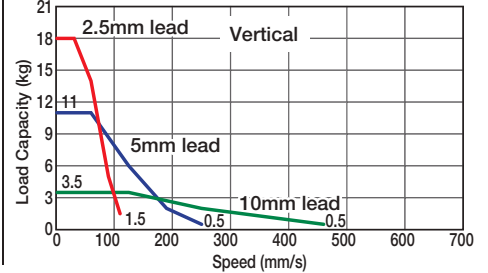
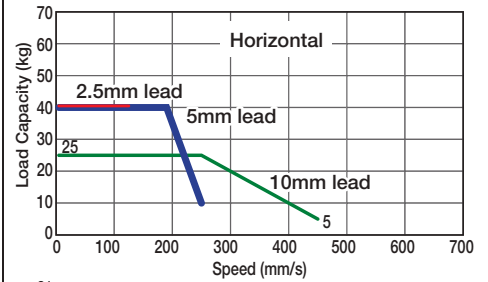

Actuator Specifications

Lead and Load Capacity

(Note 1) Please note that the maximum load capacity decreases as the speed increases.

Model	Lead (mm)	Max. Load Capacity (Note 1)		Maximum Push Force (N)(Note 2)	Stroke (mm)
		Horizontal (kg)	Vertical (kg)		
RCP2-RGS4C-I-42P-10-①-②-③-④	10	~ 25	~ 3.5	150	50 ~ 300 (50mm increments)
RCP2-RGS4C-I-42P-5-①-②-③-④	5	~ 40	~ 11	284	
RCP2-RGS4C-I-42P-2.5-①-②-③-④	2.5	40	~ 18	358	

Legend: ① Stroke ② Compatible controller ③ Cable length ④ Options

(Note 2) See page A-69 for the pushing force graphs.

Stroke and Maximum Speed

Stroke / Lead	50 ~ 200 (50mm increments)	250 (mm)	300 (mm)
	10	458	458
5	250	237	175
2.5	125 <114>	118 <114>	87

* The values enclosed in < > apply for vertical usage. (Unit: mm/s)

Cable List

Type	Cable Symbol
Standard	P (1m)
	S (3m)
	M (5m)
Special Lengths	X06 (6m) ~ X10 (10m)
	X11 (11m) ~ X15 (15m)
	X16 (16m) ~ X20 (20m)
Robot Cable	R01 (1m) ~ R03 (3m)
	R04 (4m) ~ R05 (5m)
	R06 (6m) ~ R10 (10m)
	R11 (11m) ~ R15 (15m)
	R16 (16m) ~ R20 (20m)

* See page A-39 for cables for maintenance.

Actuator Specifications

Item	Description
Drive System	Ball screw ø8mm C10 grade
Positioning Repeatability	±0.02mm
Lost Motion	0.1mm or less
Guide	Single guide Guide rod diameter ø10mm Ball bush type
Rod Diameter	ø22mm
Non-rotating accuracy of rod	±0.05 deg
Ambient Operating Temp./Humidity	0 ~ 40°C, 85% RH or less (non-condensing)

Option List

Name	Option Code	See Page
Brake	B	→ A-25
Foot bracket	FT	→ A-29
Reversed-home	NM	→ A-33

Dimensions

CAD drawings can be downloaded from IAI website. www.robocylinder.de



For Special Orders P. A-9

- *1. The motor-encoder cable is connected here. See page A-39 for details on cables.
- *2. When homing, the rod moves to the M.E.; therefore, please watch for any interference with the surrounding objects.
ME: Mechanical end
SE: Stroke end
The values enclosed in "()" are reference dimensions.
- *3. Please note that there is no T-slot on the bottom of the brake unit.

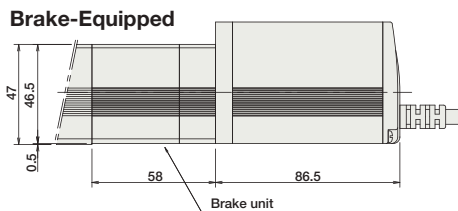
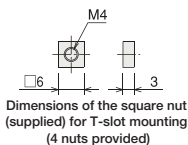
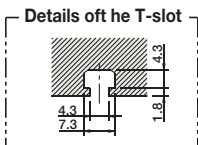
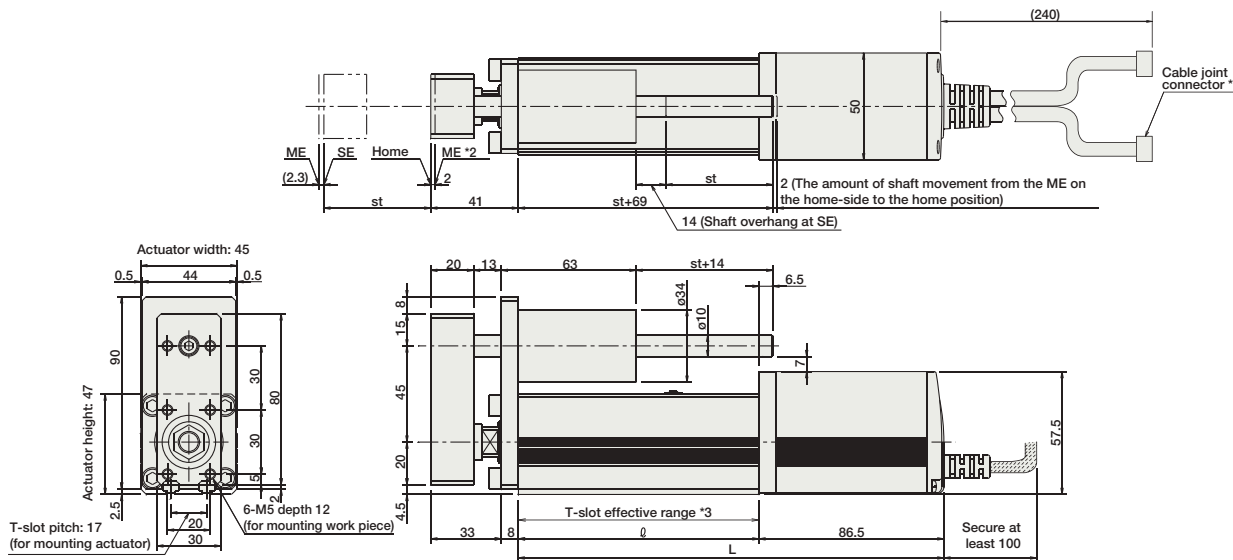

* Compared to the standard model, the brake-equipped model is longer by 58mm and heavier by 0.4kg.

Dimensions/Weight by Stroke

Stroke	50	100	150	200	250	300
ℓ	112.5	162.5	212.5	262.5	312.5	362.5
L	199	249	299	349	399	449
Weight (kg)	1.8	2.1	2.4	2.7	2.9	3.2

Compatible Controllers

The RCP2 series actuators can operate with the controllers below. Select the controller according to your usage.

Name	External View	Model	Description	Max. Positioning Points	Input Voltage	Power Supply Capacity	See Page
Solenoid Valve Type		PMEC-C-42PI-NP-2-2	Easy-to-use controller, even for beginners	3 points	AC115V AC230V	See P481	→ P477
		PSEP-C-42PI-NP-2-0	Operable with same signal as solenoid valve. Supports both single and double solenoid types. No homing necessary with simple absolute type.				
Splash-Proof Solenoid Valve Type		PSEP-CW-42PI-NP-2-0					
Positioner Type		PCON-C-42PI-NP-2-0	Positioning is possible for up to 512 points	512 points	DC24V	2A max.	
Safety-Compliant Positioner Type		PCON-CG-42PI-NP-2-0					
Pulse Train Input Type (Differential Line Driver)		PCON-PL-42PI-NP-2-0	Pulse train input type with differential line driver support	(-)	DC24V	2A max.	→ P525
Pulse Train Input Type (Open Collector)		PCON-PO-42PI-NP-2-0	Pulse train input type with open collector support				
Serial Communication Type		PCON-SE-42PI-N-0-0	Dedicated to serial communication	64 points			
Field Network Type		RPCON-42P	Dedicated to field network	768 points			→ P503
Program Control Type		PSEL-C-1-42PI-NP-2-0	Programmed operation is possible. Operation is possible on up to 2 axes	1500 points			→ P557

* This is for the single-axis PSEL.

- Slider Type
- Mini
- Standard
- Controllers Integrated
- Rod Type
- Mini
- Standard
- Controllers Integrated
- Table/Arm /Flat Type
- Mini
- Standard
- Gripper/ Rotary Type
- Linear Motor Type
- Cleanroom Type
- Splash Proof
- Controllers
- PMEC /AMEC
- PSEP /ASEP
- ROBO NET
- ERC2
- PCON
- ACON
- SCON
- PSEL
- ASEL
- SSEL
- XSEL
- Pulse Motor
- Servo Motor (24V)
- Servo Motor (230V)
- Linear Motor

- Slider Type
- Mini
- Standard
- Controllers Integrated
- Rod Type
- Mini
- Standard
- Controllers Integrated
- Table/Arm /Flat Type
- Mini
- Standard
- Gripper/ Rotary Type
- Linear Motor Type
- Cleanroom Type
- Splash Proof
- Controllers
- PMEC /AMEC
- PSEP /ASEP
- ROBO NET
- ERC2
- PCON
- ACON
- SCON
- PSEL
- ASEL
- SSEL
- XSEL
- Pulse Motor
- Servo Motor (24V)
- Servo Motor (230V)
- Linear Motor

RCP2-RGS6C RoboCylinder Rod Type with Single Guide 64mm Width Pulse Motor Straight Type

■ Configuration: **RCP2** - **RGS6C** - **I** - **56P** - - - - -

Series	Type	Encoder	Motor	Lead	Stroke	Compatible Controllers	Cable Length	Option
		I: Incremental * The Simple absolute encoder is also considered type "I".	56P: Pulse motor 56 <input type="checkbox"/> size	16 : 16mm 8 : 8mm 4 : 4mm	50: 50mm 300: 300mm (50mm pitch increments)	P1: PCON RPCON PSEL P3: PMEAC PSEP	N : None P : 1m S : 3m M : 5m X <input type="checkbox"/> : Custom R <input type="checkbox"/> : Robot cable	B : Brake FT : Foot bracket NM: Reversed-home

* See page Pre-35 for an explanation of the naming convention.



Technical References P. A-5

POINT Notes on Selection

- When the stroke increases, the maximum speed will drop to prevent the ball screw from reaching the critical rotational speed. Use the actuator specification table below to check the maximum speed at the stroke you desire.
- Since the RCP2 series use a pulse motor, the load capacity decreases at high speeds. Check in the Speed vs. Load Capacity graph to see if your desired speed and load capacity are supported.
- The load capacity is based on operation at an acceleration of 0.2G. 0.2G is the upper limit of the acceleration. In addition, the horizontal load capacity is based on the use of an external guide. See the technical resources (page A-82) for the allowable weight using the supplied guide alone.

■ Speed vs. Load Capacity
Due to the characteristics of the pulse motor, the RCP2 series' load capacity decreases at high speeds. In the table below, check if your desired speed and load capacity are supported.

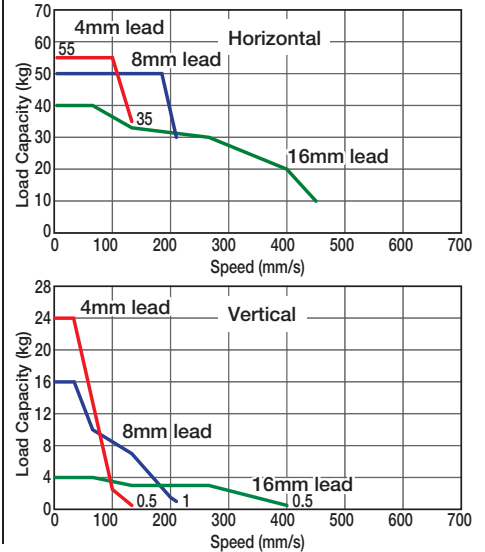

Actuator Specifications						Stroke and Maximum Speed	
■ Lead and Load Capacity					(Note 1) Please note that the maximum load capacity decreases as the speed increases.		
Model	Lead (mm)	Max. Load Capacity (Note 1)	Maximum Push Force (N)(Note 2)	Stroke (mm)	Stroke	50 ~ 300 (50mm increments)	
		Horizontal (kg)	Vertical (kg)		Lead		
RCP2-RGS6C-I-56P-16-①-②-③-④	16	~ 40	~ 4	240	16	450 <400>	
RCP2-RGS6C-I-56P-8-①-②-③-④	8	~ 50	~ 16	470	8	210	
RCP2-RGS6C-I-56P-4-①-②-③-④	4	~ 55	~ 24	800	4	130	

Legend: ① Stroke ② Compatible controller ③ Cable length ④ Options (Note 2) See page A-69 for the pushing force graphs. * The values enclosed in < > apply for vertical usage. (Unit: mm/s)

Type	Cable Symbol
Standard	P (1m)
	S (3m)
	M (5m)
Special Lengths	X06 (6m) ~ X10 (10m)
	X11 (11m) ~ X15 (15m)
	X16 (16m) ~ X20 (20m)
Robot Cable	R01 (1m) ~ R03 (3m)
	R04 (4m) ~ R05 (5m)
	R06 (6m) ~ R10 (10m)
	R11 (11m) ~ R15 (15m)
	R16 (16m) ~ R20 (20m)

* See page A-39 for cables for maintenance.

Item	Description
Drive System	Ball screw ø12mm C10 grade
Positioning Repeatability	±0.02mm
Lost Motion	0.1 mm or less
Guide	Single guide Guide rod diameter ø12mm Ball bush type
Rod Diameter	ø30mm
Non-rotating accuracy of rod	±0.05 deg
Ambient Operating Temp./Humidity	0 ~ 40°C, 85% RH or less (non-condensing)

Name	Option Code	See Page
Brake	B	→ A-25
Foot bracket	FT	→ A-29
Reversed-home	NM	→ A-33

Dimensions

CAD drawings can be downloaded from IAI website. www.robocylinder.de



For Special Orders P. A-9

- *1. The motor-encoder cable is connected here. See page A-39 for details on cables.
- *2. When homing, the rod moves to the M.E.; therefore, please watch for any interference with the surrounding objects.
ME: Mechanical end
SE: Stroke end
The values enclosed in "() " are reference dimensions.
- *3. Please note that there is no T-slot on the bottom of the brake unit.

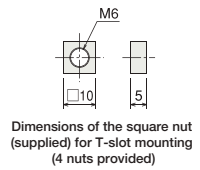
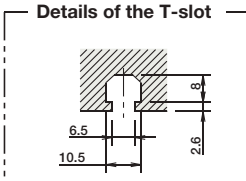
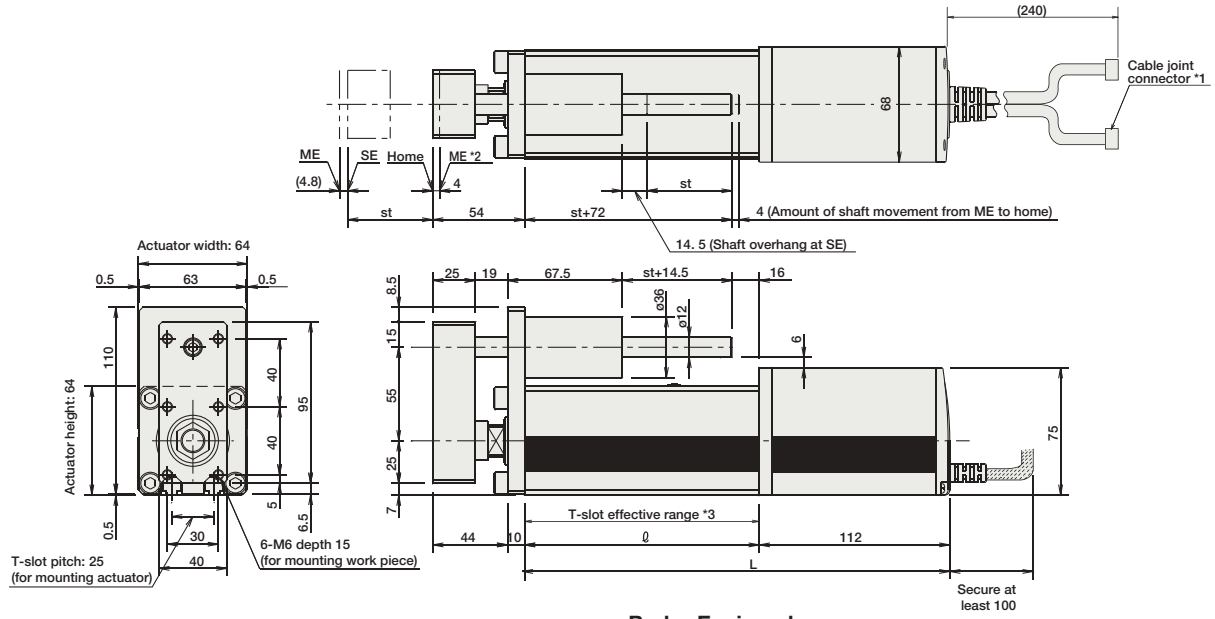

Brake-Equipped

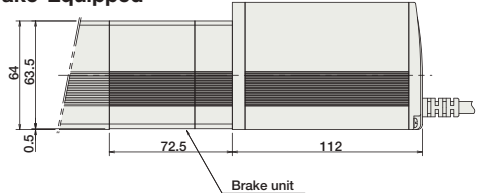

* Compared to the standard model, the brake-equipped model is longer by 72.5mm and heavier by 0.9kg.

Dimensions/Weight by Stroke

Stroke	50	100	150	200	250	300
R	138	188	238	288	338	388
L	250	300	350	400	450	500
Weight (kg)	3.6	4.4	5.0	5.5	6.1	6.6

Compatible Controllers

The RCP2 series actuators can operate with the controllers below. Select the controller according to your usage.

Name	External View	Model	Description	Max. Positioning Points	Input Voltage	Power Supply Capacity	See Page
Solenoid Valve Type		PMEC-C-56PI-NP-2-2	Easy-to-use controller, even for beginners	3 points	AC115V AC230V	See P481	→ P477
		PSEP-C-56PI-NP-2-0	Operable with same signal as solenoid valve. Supports both single and double solenoid types. No homing necessary with simple absolute type.				
Splash-Proof Solenoid Valve Type		PSEP-CW-56PI-NP-2-0					
Positioner Type		PCON-C-56PI-NP-2-0	Positioning is possible for up to 512 points	512 points	DC24V	2A max.	
Safety-Compliant Positioner Type		PCON-CG-56PI-NP-2-0					
Pulse Train Input Type (Differential Line Driver)		PCON-PL-56PI-NP-2-0	Pulse train input type with differential line driver support	(-)	DC24V	2A max.	→ P525
Pulse Train Input Type (Open Collector)		PCON-PO-56PI-NP-2-0	Pulse train input type with open collector support				
Serial Communication Type		PCON-SE-56PI-N-0-0	Dedicated to serial communication	64 points			
Field Network Type		RPCON-56P	Dedicated to field network	768 points			→ P503
Program Control Type		PSEL-C-1-56PI-NP-2-0	Programmed operation is possible Operation is possible on up to 2 axes	1500 points			→ P557

* This is for the single-axis PSEL.

- Slider Type
- Mini
- Standard
- Controllers Integrated
- Rod Type
- Mini
- Standard
- Controllers Integrated
- Table/Arm /Flat Type
- Mini
- Standard
- Gripper/ Rotary Type
- Linear Motor Type
- Cleanroom Type
- Splash Proof
- Controllers
- PMEC /AMEC
- PSEP /ASEP
- ROBO NET
- ERC2
- PCON
- ACON
- SCON
- PSEL
- ASEL
- SSEL
- XSEL
- Pulse Motor
- Servo Motor (24V)
- Servo Motor (230V)
- Linear Motor

- Slider Type
- Mini
- Standard
- Controllers Integrated
- Rod Type
- Mini
- Standard
- Controllers Integrated
- Table/Arm /Flat Type
- Mini
- Standard
- Gripper/ Rotary Type
- Linear Motor Type
- Cleanroom Type
- Splash Proof
- Controllers
- PMEC /AMEC
- PSEP /ASEP
- ROBO NET
- ERC2
- PCON
- ACON
- SCON
- PSEL
- ASEL
- SSEL
- XSEL
- Pulse Motor
- Servo Motor (24V)
- Servo Motor (230V)
- Linear Motor

RCP2-SRGS4R

RoboCylinder Short Rod Type with Single Guide 45mm Width
Pulse Motor Side-Mounted Motor

■ Configuration: **RCP2 – SRGS4R – I – 35P**

Series	Type	Encoder	Motor	Lead	Stroke	Compatible Controllers	Cable Length	Option
		I: Incremental * The Simple absolute encoder is also considered type "I".	35P: Pulse motor 35 □ size	5 : 5mm 2.5 : 2.5mm	20: 20mm 200: 200mm (10mm pitch increments) * Set in 50mm increments over 100mm	P1: PCON RCON PSEL P3: PMEC PSEP	N : None P : 1m S : 3m M : 5m X □ □ : Custom	See options below

* See page Pre-35 for an explanation of the naming convention.

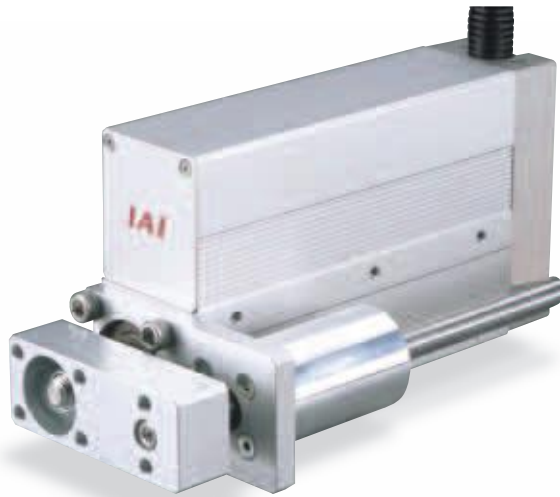

Technical References P. A-5



- Since the RCP2 series use a pulse motor, the load capacity decreases at high speeds. Check in the Speed vs. Load Capacity graph to see if your desired speed and load capacity are supported.
- The load capacity is based on operation at an acceleration of 0.3G (0.2G for the 2.5mm-lead model, or when used vertically). This is the upper limit of the acceleration.
- The horizontal load capacity is based on the use of an external guide. See the technical resources (page A-82) for the allowable weight using the supplied guide alone.

■ Speed vs. Load Capacity
Due to the characteristics of the pulse motor, the RCP2 series' load capacity decreases at high speeds. In the table below, check if your desired speed and load capacity are supported.

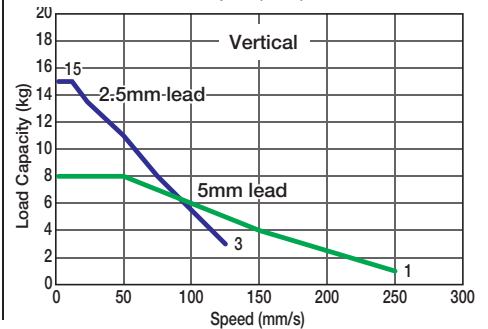
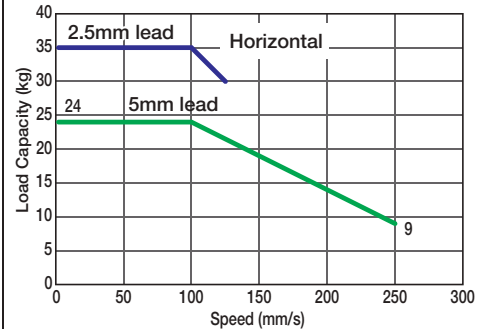

Actuator Specifications

Lead and Load Capacity

(Note 1) Please note that the maximum load capacity decreases as the speed increases.

Model	Lead (mm)	Max. Load Capacity (Note 1)		Maximum Push Force (N) (Note 2)	Stroke (mm)
		Horizontal (kg)	Vertical (kg)		
RCP2-SRGS4R-I-35P-5-①-②-③-④	5	~ 24	~ 8	90	20 ~ 200 (10mm increments) (Note 3)
RCP2-SRGS4R-I-35P-2.5-①-②-③-④	2.5	~ 35	~ 15	170	

Legend: ① Stroke ② Compatible controller ③ Cable length ④ Options

(Note 2) See page A-69 for the pushing force graphs.
(Note 3) 50mm increments over 100mm.

(Unit: mm/s)

Stroke and Maximum Speed

Lead	Stroke	20 ~ 200 (10mm increments)
	5	
2.5		125

Cable List

Type	Cable Symbol
Standard (Robot Cables)	P (1m)
	S (3m)
	M (5m)
Special Lengths	X06 (6m) ~ X10 (10m)
	X11 (11m) ~ X15 (15m)
	X16 (16m) ~ X20 (20m)

* The cable is a motor-encoder integrated cable, and is provided as a robot cable.

* See page A-39 for cables for maintenance.

Option List

Name	Option Code	See Page
Brake	B	→ A-25
Flange bracket (back)	FLR	→ A-28
Foot bracket 1 (base mounting)	FT	→ A-29
Foot bracket 2 (right/left side mounting)	FT2/FT4	→ A-31
Guide mounting direction	GS2 ~ GS4	→ A-156
Reversed-home	NM	→ A-33

* The brake is available for strokes of 70mm or more.

* Please be sure that the mounting direction of the guide is specified in the product name.

* The guide and the foot bracket cannot be mounted in the same direction.

Actuator Specifications

Item	Description
Drive System	Ball screw ø8mm C10 grade
Positioning Repeatability	±0.02mm
Lost Motion	0.1mm or less
Rod Diameter	ø22mm
Non-rotating accuracy of rod	±0.05 deg
Ambient Operating Temp./Humidity	0 ~ 40°C, 85% RH or less (non-condensing)

Dimensions

CAD drawings can be downloaded from IAI website. www.robocylinder.de

For Special Orders P. A-9

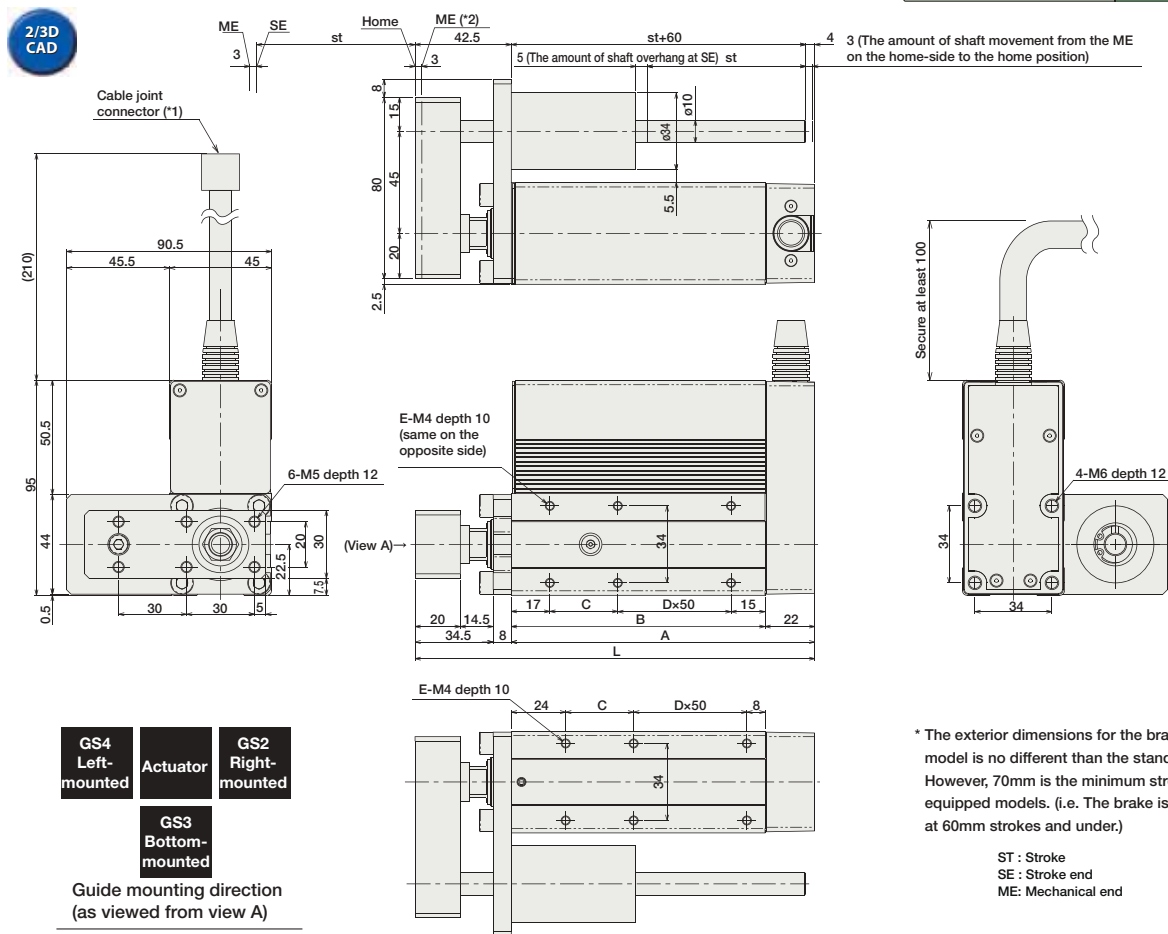

(*1) The motor-encoder cable is connected here. See page A-39 for details on cables.
(*2) When homing, the rod moves to the mechanical end position; therefore, please watch for any interference with the surrounding objects.

Dimensions/Weight by Stroke (Add 0.2kg for brake equipped)

Stroke	20	30	40	50	60	70	80	90	100	150	200
L	126.5	136.5	146.5	156.5	166.5	176.5	186.5	196.5	206.5	256.5	306.5
A	84	94	104	114	124	134	144	154	164	214	264
B	62	72	82	92	102	112	122	132	142	192	242
C	30	40	50	60	70	80	90	100	110	160	210
D	0	0	0	0	0	1	1	1	1	2	3
E	4	4	4	4	4	6	6	6	6	8	10
Weight (kg)	1.2	1.27	1.34	1.41	1.48	1.54	1.61	1.68	1.75	2.09	2.43

Compatible Controllers

The RCP2 series actuators can operate with the controllers below. Select the controller according to your usage.

Name	External View	Model	Description	Max. Positioning Points	Input Voltage	Power Supply Capacity	See Page
Solenoid Valve Type		PMEC-C-35PI-NP-2-2	Easy-to-use controller, even for beginners	3 points	AC115V AC230V	See P481	→ P477
		PSEP-C-35PI-NP-2-0	Operable with same signal as solenoid valve. Supports both single and double solenoid types. No homing necessary with simple absolute type.				
Splash-Proof Solenoid Valve Type		PSEP-CW-35PI-NP-2-0					
Positioner Type		PCON-C-35PI-NP-2-0	Positioning is possible for up to 512 points	512 points			
Safety-Compliant Positioner Type		PCON-CG-35PI-NP-2-0					
Pulse Train Input Type (Differential Line Driver)		PCON-PL-35PI-NP-2-0	Pulse train input type with differential line driver support	(-)	DC24V	2A max.	→ P525
Pulse Train Input Type (Open Collector)		PCON-PO-35PI-NP-2-0	Pulse train input type with open collector support				
Serial Communication Type		PCON-SE-35PI-N-0-0	Dedicated to serial communication	64 points			
Field Network Type		RPCON-35P	Dedicated to field network	768 points			→ P503
Program Control Type		PSEL-C-1-35PI-NP-2-0	Programmed operation is possible. Operation is possible on up to 2 axes	1500 points			→ P557

* This is for the single-axis PSEL.

- Slider Type
- Mini
- Standard
- Controllers Integrated
- Rod Type
- Mini
- Standard
- Controllers Integrated
- Table/Arm /Flat Type
- Mini
- Standard
- Gripper/ Rotary Type
- Linear Motor Type
- Cleanroom Type
- Splash Proof
- Controllers
- PMEC /AMEC
- PSEP /ASEP
- ROBO NET
- ERC2
- PCON
- ACON
- SCON
- PSEL
- ASEL
- SSEL
- XSEL
- Pulse Motor
- Servo Motor (24V)
- Servo Motor (230V)
- Linear Motor

RCP2-RGD3C

RoboCylinder Rod Type with Double Guide 35mm Width Pulse Motor Straight Type

■ Configuration: **RCP2** - **RGD3C** - **I** - **28P** - [] - [] - [] - [] - []

Series	Type	Encoder	Motor	Lead	Stroke	Compatible Controllers	Cable Length	Option
		I: Incremental * The Simple absolute encoder is also considered type "I".	28P: Pulse motor 28 □ size	5 : 5mm 2.5 : 2.5mm	50: 50mm 200: 200mm (50mm pitch increments)	P1: PCON RCON PSEL P3: PMEC PSEP	N : None P : 1m S : 3m M : 5m X □ : Custom R □ : Robot cable	FT : Foot bracket NM: Reversed-home

* See page Pre-35 for an explanation of the naming convention.

* Pictured: RGD4C



Technical References P. A-5



- When the stroke increases, the maximum speed will drop to prevent the ball screw from reaching the critical rotational speed. Use the actuator specification table below to check the maximum speed at the stroke you desire.
- Since the RCP2 series use a pulse motor, the load capacity decreases at high speeds. Check in the Speed vs. Load Capacity graph to see if your desired speed and load capacity are supported.
- The load capacity is based on operation at an acceleration of 0.2G. 0.2G is the upper limit of the acceleration. In addition, the horizontal load capacity is based on the use of an external guide. See the technical resources (page A-83) for the allowable weight using the supplied guide alone.

Speed vs. Load Capacity

Due to the characteristics of the pulse motor, the RCP2 series' load capacity decreases at high speeds. In the table below, check if your desired speed and load capacity are supported.

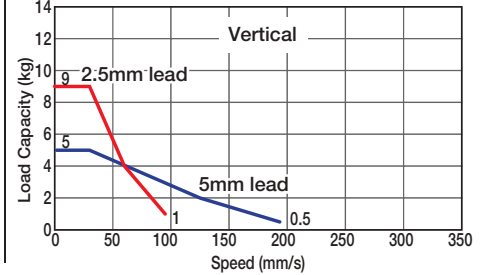
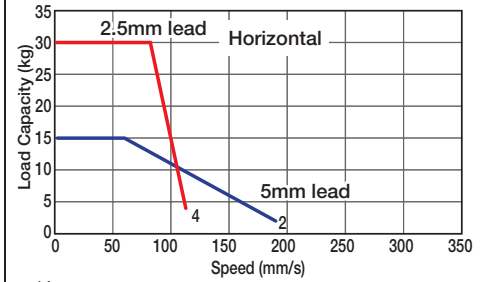

Actuator Specifications

Lead and Load Capacity

(Note 1) Please note that the maximum load capacity decreases as the speed increases.

Model	Lead (mm)	Max. Load Capacity (Note 1)		Maximum Push Force (N)(Note 2)	Stroke (mm)
		Horizontal (kg)	Vertical (kg)		
RCP2-RGD3C-I-28P-5-①-②-③-④	5	~ 15	~ 5	73.5	50 ~ 200 (50mm increments)
RCP2-RGD3C-I-28P-2.5-①-②-③-④	2.5	~ 30	~ 9	156.8	50 ~ 200 (50mm increments)

Legend: ① Stroke ② Compatible controller ③ Cable length ④ Options

(Note 2) See page A-69 for the pushing force graphs.

(Unit: mm/s)

Stroke and Maximum Speed

Stroke / Lead	50 ~ 200 (50mm increments)	
	5	187
2.5	114 <93>	

Cable List

Type	Cable Symbol
Standard	P (1m)
	S (3m)
	M (5m)
Special Lengths	X06 (6m) ~ X10 (10m)
	X11 (11m) ~ X15 (15m)
	X16 (16m) ~ X20 (20m)
	X21 (21m) ~ X25 (25m)
Robot Cable	R01 (1m) ~ R03 (3m)
	R04 (4m) ~ R05 (5m)
	R06 (6m) ~ R10 (10m)
	R11 (11m) ~ R15 (15m)
	R16 (16m) ~ R20 (20m)
	R21 (21m) ~ R25 (25m)

* See page A-39 for cables for maintenance.

Actuator Specifications

Item	Description
Drive System	Ball screw ø8mm C10 grade
Positioning Repeatability	±0.02mm
Lost Motion	0.1mm or less
Guide	Double guide Guide rod diameter ø10mm Ball bush type
Rod Diameter	ø22mm
Non-rotating accuracy of rod	±0.05 deg
Ambient Operating Temp./Humidity	0 ~ 40°C, 85% RH or less (non-condensing)

Option List

Name	Option Code	See Page
Foot bracket	FT	→ A-29
Reversed-home	NM	→ A-33

Dimensions

CAD drawings can be downloaded from IAI website. www.robocylinder.de



For Special Orders P. A-9

- *1. The motor-encoder cable is connected here. See page A-39 for details on cables.
- *2. When homing, the rod moves to the M.E.; therefore, please watch for any interference with the surrounding objects.
ME: Mechanical end
SE: Stroke end
The values enclosed in "()" are reference dimensions.

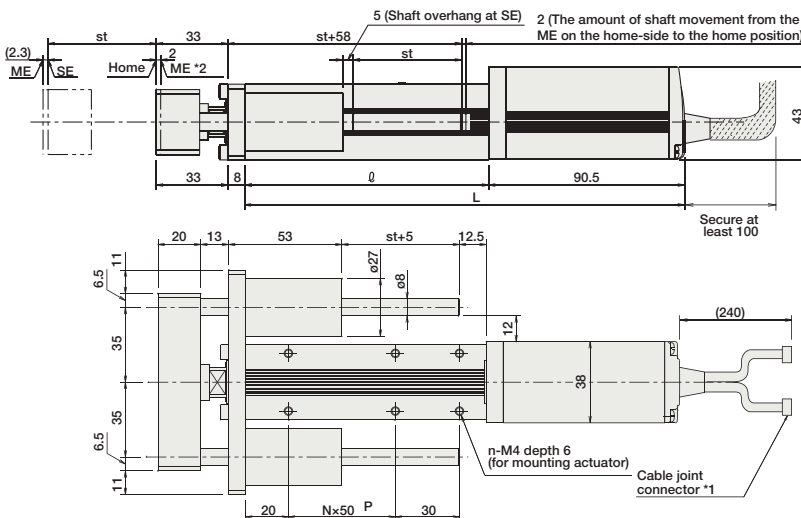
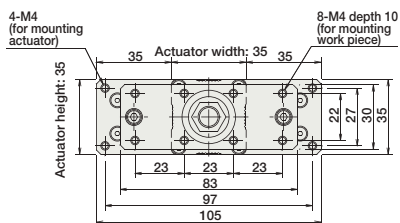

■ Dimensions/Weight by Stroke

Stroke	50	100	150	200
ℓ	112.5	162.5	212.5	262.5
L	203	253	303	353
N	1	2	3	4
n	6	8	10	12
Weight (kg)	1.1	1.3	1.4	1.6

Compatible Controllers

The RCP2 series actuators can operate with the controllers below. Select the controller according to your usage.

Name	External View	Model	Description	Max. Positioning Points	Input Voltage	Power Supply Capacity	See Page
Solenoid Valve Type		PMEC-C-28SPI-NP-2-2	Easy-to-use controller, even for beginners	3 points	AC115V AC230V	See P481	→ P477
		PSEP-C-28SPI-NP-2-0	Operable with same signal as solenoid valve. Supports both single and double solenoid types. No homing necessary with simple absolute type.				→ P487
Splash-Proof Solenoid Valve Type		PSEP-CW-28SPI-NP-2-0					
Positioner Type		PCON-C-28SPI-NP-2-0	Positioning is possible for up to 512 points	512 points	DC24V	2A max.	
Safety-Compliant Positioner Type		PCON-CG-28SPI-NP-2-0					
Pulse Train Input Type (Differential Line Driver)		PCON-PL-28SPI-NP-2-0	Pulse train input type with differential line driver support	(-)	DC24V	2A max.	→ P525
Pulse Train Input Type (Open Collector)		PCON-PO-28SPI-NP-2-0	Pulse train input type with open collector support				
Serial Communication Type		PCON-SE-28SPI-N-0-0	Dedicated to serial communication	64 points			
Field Network Type		RPCON-28SP	Dedicated to field network	768 points			→ P503
Program Control Type		PSEL-C-1-28SPI-NP-2-0	Programmed operation is possible. Operation is possible on up to 2 axes	1500 points			→ P557

* This is for the single-axis PSEL.

- Slider Type
- Mini
- Standard
- Controllers Integrated
- Rod Type
- Mini
- Standard
- Controllers Integrated
- Table/Arm /Flat Type
- Mini
- Standard
- Gripper/ Rotary Type
- Linear Motor Type
- Cleanroom Type
- Splash Proof
- Controllers
- PMEC /AMEC
- PSEP /ASEP
- ROBO NET
- ERC2
- PCON
- ACON
- SCON
- PSEL
- ASEL
- SSEL
- XSEL
- Pulse Motor
- Servo Motor (24V)
- Servo Motor (230V)
- Linear Motor

- Slider Type
- Mini
- Standard
- Controllers Integrated
- Rod Type
- Mini
- Standard
- Controllers Integrated
- Table/Arm /Flat Type
- Mini
- Standard
- Gripper/ Rotary Type
- Linear Motor Type
- Cleanroom Type
- Splash Proof
- Controllers
- PMEC /AMEC
- PSEP /ASEP
- ROBO NET
- ERC2
- PCON
- ACON
- SCON
- PSEL
- ASEL
- SSEL
- XSEL
- Pulse Motor
- Servo Motor (24V)
- Servo Motor (230V)
- Linear Motor

RCP2-RGD4C RoboCylinder Rod Type with Double Guide 45mm Width Pulse Motor Straight Type

■ Configuration: **RCP2** — **RGD4C** — **I** — **42P** — — — — —

Series	Type	Encoder	Motor	Lead	Stroke	Compatible Controllers	Cable Length	Option
		I: Incremental * The Simple absolute encoder is also considered type "I".	42P: Pulse motor 42 □ size	10 : 10mm 5 : 5mm 2.5 : 2.5mm	50: 50mm 300: 300mm (50mm pitch increments)	P1: PCON RPCON PSEL P3: PMEC PSEP	N : None P : 1m S : 3m M : 5m X □ : Custom R □ : Robot cable	B : Brake FT : Foot bracket NM: Reversed-home

* See page Pre-35 for an explanation of the naming convention.



Technical References P. A-5

- POINT** Notes on Selection
- When the stroke increases, the maximum speed will drop to prevent the ball screw from reaching the critical rotational speed. Use the actuator specification table below to check the maximum speed at the stroke you desire.
 - Since the RCP2 series use a pulse motor, the load capacity decreases at high speeds. Check in the Speed vs. Load Capacity graph to see if your desired speed and load capacity are supported.
 - The load capacity is based on operation at an acceleration of 0.2G. In addition, the horizontal load capacity is based on the use of an external guide. See the technical resources (page A-83) for the allowable weight using the supplied guide alone.

■ Speed vs. Load Capacity
Due to the characteristics of the pulse motor, the RCP2 series' load capacity decreases at high speeds. In the table below, check if your desired speed and load capacity are supported.

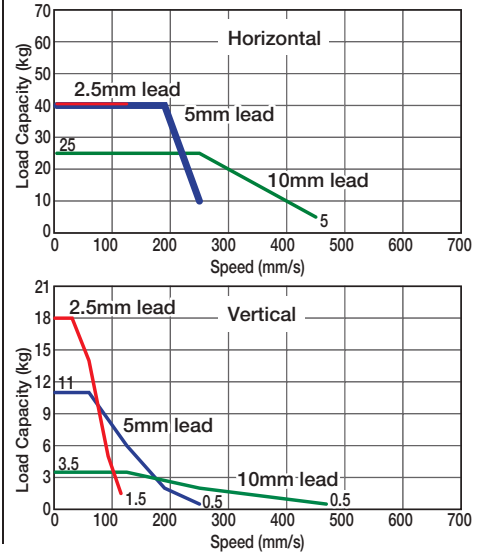

Actuator Specifications

■ Lead and Load Capacity (Note 1) Please note that the maximum load capacity decreases as the speed increases.

Model	Lead (mm)	Max. Load Capacity (Note 1)		Maximum Push Force (N)(Note 2)	Stroke (mm)
		Horizontal (kg)	Vertical (kg)		
RCP2-RGD4C-I-42P-10-①-②-③-④	10	~ 25	~ 3.5	150	50 ~ 300 (50mm increments)
RCP2-RGD4C-I-42P-5-①-②-③-④	5	~ 40	~ 11	284	
RCP2-RGD4C-I-42P-2.5-①-②-③-④	2.5	40	~ 18	358	

Legend: ① Stroke ② Compatible controller ③ Cable length ④ Options (Note 2) See page A-69 for the pushing force graphs. * The values enclosed in < > apply for vertical usage. (Unit: mm/s)

■ Stroke and Maximum Speed

Stroke / Lead	50 ~ 200 (50mm increments)	250 (mm)	300 (mm)
10	458	458	350
5	250	237	175
2.5	125 <114>	118 <114>	87

Cable List

Type	Cable Symbol
Standard	P (1m)
	S (3m)
	M (5m)
Special Lengths	X06 (6m) ~ X10 (10m)
	X11 (11m) ~ X15 (15m)
	X16 (16m) ~ X20 (20m)
	X21 (21m) ~ X25 (25m)
Robot Cable	R01 (1m) ~ R03 (3m)
	R04 (4m) ~ R05 (5m)
	R06 (6m) ~ R10 (10m)
	R11 (11m) ~ R15 (15m)
	R16 (16m) ~ R20 (20m)
	R21 (21m) ~ R25 (25m)

* See page A-39 for cables for maintenance.

Option List

Name	Option Code	See Page
Brake	B	→ A-25
Foot bracket	FT	→ A-29
Reversed-home	NM	→ A-33

Actuator Specifications

Item	Description
Drive System	Ball screw ø8mm C10 grade
Positioning Repeatability	±0.02mm
Lost Motion	0.1mm or less
Guide	Double guide Guide rod diameter ø10mm Ball bush type
Rod Diameter	ø22mm
Non-rotating accuracy of rod	±0.05 deg
Ambient Operating Temp./Humidity	0 ~ 40°C, 85% RH or less (non-condensing)

Dimensions

CAD drawings can be downloaded from IAI website. www.robocylinder.de

For Special Orders P. A-9



- *1. The motor-encoder cable is connected here. See page A-39 for details on cables.
- *2. When homing, the rod moves to the M.E.; therefore, please watch for any interference with the surrounding objects.
ME: Mechanical end
SE: Stroke end
The values enclosed in "()" are reference dimensions.
- *3. Please note that there is no T-slot on the bottom of the brake unit.

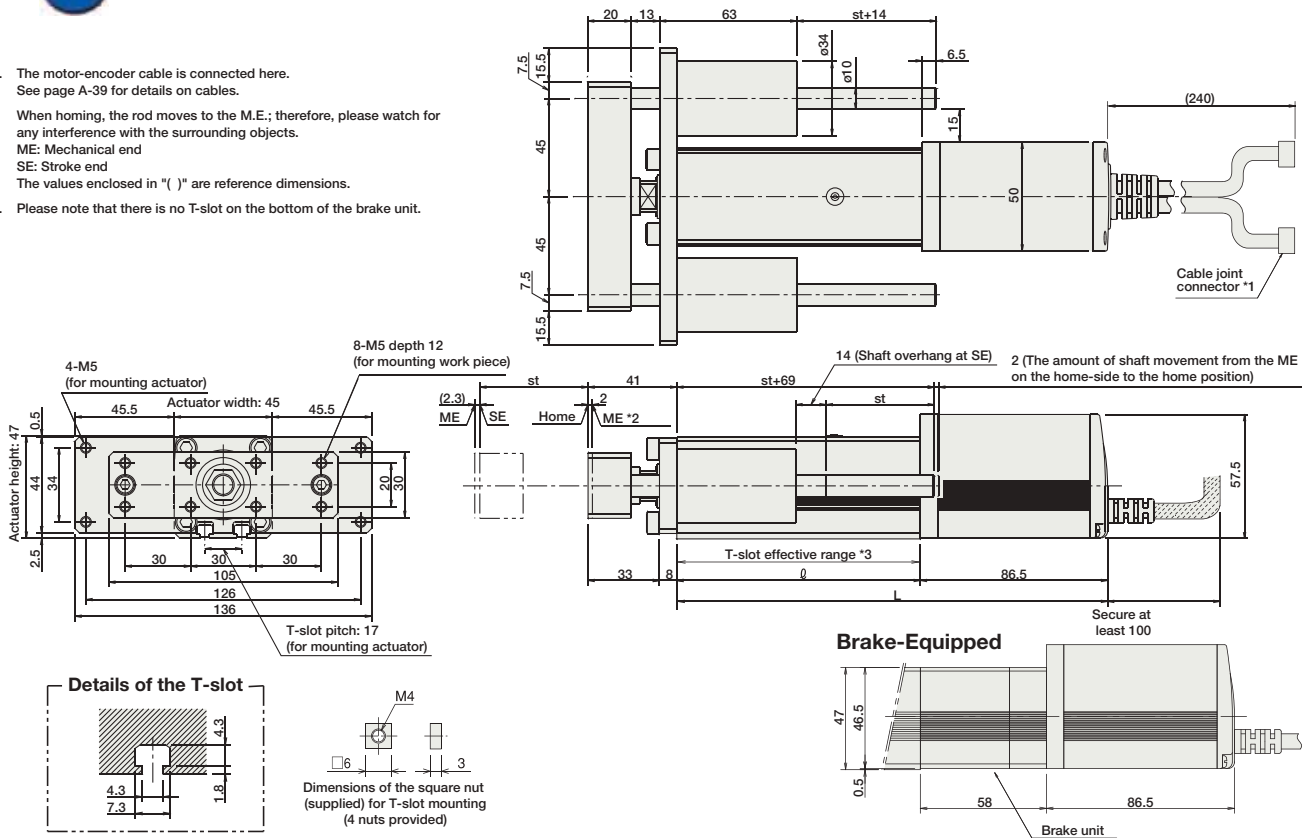

* Compared to the standard model, the brake-equipped model is longer by 58mm and heavier by 0.4kg.

■ Dimensions/Weight by Stroke

Stroke	50	100	150	200	250	300
ℓ	112.5	162.5	212.5	262.5	312.5	362.5
L	199	249	299	349	399	449
Weight (kg)	2.2	2.5	2.8	3.1	3.4	3.7

Compatible Controllers

The RCP2 series actuators can operate with the controllers below. Select the controller according to your usage.

Name	External View	Model	Description	Max. Positioning Points	Input Voltage	Power Supply Capacity	See Page
Solenoid Valve Type		PMEC-C-42PI-NP-2-2	Easy-to-use controller, even for beginners	3 points	AC115V AC230V	See P481	→ P477
Splash-Proof Solenoid Valve Type		PSEP-C-42PI-NP-2-0	Operable with same signal as solenoid valve. Supports both single and double solenoid types. No homing necessary with simple absolute type.				→ P487
Positioner Type		PCON-C-42PI-NP-2-0	Positioning is possible for up to 512 points	512 points	DC24V	2A max.	
Safety-Compliant Positioner Type		PCON-CG-42PI-NP-2-0					
Pulse Train Input Type (Differential Line Driver)		PCON-PL-42PI-NP-2-0	Pulse train input type with differential line driver support	(-)	DC24V	2A max.	→ P525
Pulse Train Input Type (Open Collector)		PCON-PO-42PI-NP-2-0	Pulse train input type with open collector support				
Serial Communication Type		PCON-SE-42PI-N-0-0	Dedicated to serial communication	64 points	DC24V	2A max.	
Field Network Type		RPCON-42P	Dedicated to field network	768 points			→ P503
Program Control Type		PSEL-C-1-42PI-NP-2-0	Programmed operation is possible. Operation is possible on up to 2 axes	1500 points	DC24V	2A max.	→ P557

* This is for the single-axis PSEL.

- Slider Type
- Mini
- Standard
- Controllers Integrated
- Rod Type
- Mini
- Standard
- Controllers Integrated
- Table/Arm /Flat Type
- Mini
- Standard
- Gripper/ Rotary Type
- Linear Motor Type
- Cleanroom Type
- Splash Proof
- Controllers
- PMEC /AMEC
- PSEP /ASEP
- ROBO NET
- ERC2
- PCON
- ACON
- SCON
- PSEL
- ASEL
- SSEL
- XSEL
- Pulse Motor
- Servo Motor (24V)
- Servo Motor (230V)
- Linear Motor

- Slider Type
- Mini
- Standard
- Controllers Integrated
- Rod Type
- Mini
- Standard
- Controllers Integrated
- Table/Arm /Flat Type
- Mini
- Standard
- Gripper/ Rotary Type
- Linear Motor Type
- Cleanroom Type
- Splash Proof
- Controllers
- PMEC /AMEC
- PSEP /ASEP
- ROBO NET
- ERC2
- PCON
- ACON
- SCON
- PSEL
- ASEL
- SSEL
- XSEL
- Pulse Motor
- Servo Motor (24V)
- Servo Motor (230V)
- Linear Motor

RCP2-RGD6C RoboCylinder Rod Type with Double Guide 64mm Width Pulse Motor Straight Type

Configuration: RCP2 -- RGD6C -- I -- 56P -- -- -- -- --

Series	Type	Encoder	Motor	Lead	Stroke	Compatible Controllers	Cable Length	Option
		I: Incremental * The Simple absolute encoder is also considered type "I".	56P: Pulse motor 56 □ size	16 : 16mm 8 : 8mm 4 : 4 mm	50: 50mm 300: 300mm (50mm pitch increments)	P1: PCON RPCON PSEL P3: PMEC PSEP	N : None P : 1m S : 3m M : 5m X □ : Custom R □ : Robot cable	B : Brake FT : Foot bracket NM: Reversed-home

* See page Pre-35 for an explanation of the naming convention.



* Pictured: RGD4C

Technical References P. A-5

- POINT** Notes on Selection
- (1) When the stroke increases, the maximum speed will drop to prevent the ball screw from reaching the critical rotational speed. Use the actuator specification table below to check the maximum speed at the stroke you desire.
 - (2) Since the RCP2 series use a pulse motor, the load capacity decreases at high speeds. Check in the Speed vs. Load Capacity graph to see if your desired speed and load capacity are supported.
 - (3) The load capacity is based on operation at an acceleration of 0.2G. In addition, the horizontal load capacity is based on the use of an external guide. See the technical resources (page A-83) for the allowable weight using the supplied guide alone.

Speed vs. Load Capacity
Due to the characteristics of the pulse motor, the RCP2 series' load capacity decreases at high speeds. In the table below, check if your desired speed and load capacity are supported.

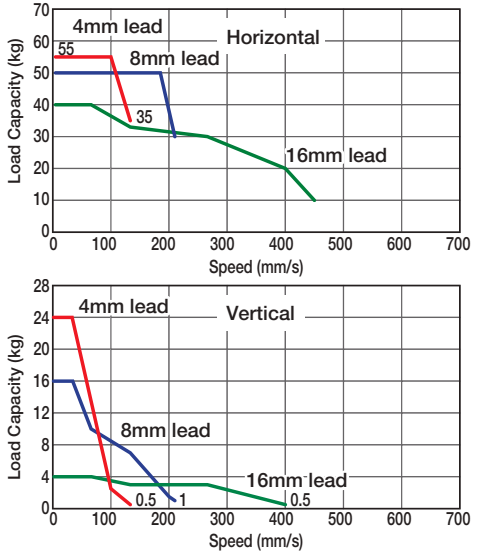

Actuator Specifications					
Lead and Load Capacity			Stroke and Maximum Speed		
Model	Lead (mm)	Max. Load Capacity (Note 1)		Maximum Push Force (N)(Note 2)	Stroke (mm)
		Horizontal (kg)	Vertical (kg)		
RCP2-RGD6C-I-56P-16-①-②-③-④	16	~ 40	~ 4	240	50 ~ 300 (50mm increments)
RCP2-RGD6C-I-56P-8-①-②-③-④	8	~ 50	~ 16	470	
RCP2-RGD6C-I-56P-4-①-②-③-④	4	~ 55	~ 24	800	

Legend: ① Stroke ② Compatible controller ③ Cable length ④ Options (Note 2) See page A-69 for the pushing force graphs. * The values enclosed in < > apply for vertical usage. (Unit: mm/s)

Cable List	
Type	Cable Symbol
Standard	P (1m)
	S (3m)
	M (5m)
Special Lengths	X06 (6m) ~ X10 (10m)
	X11 (11m) ~ X15 (15m)
	X16 (16m) ~ X20 (20m)
Robot Cable	R01 (1m) ~ R03 (3m)
	R04 (4m) ~ R05 (5m)
	R06 (6m) ~ R10 (10m)
	R11 (11m) ~ R15 (15m)
	R16 (16m) ~ R20 (20m)

* See page A-39 for cables for maintenance.

Actuator Specifications	
Item	Description
Drive System	Ball screw ø12mm C10 grade
Positioning Repeatability	±0.02mm
Lost Motion	0.1mm or less
Guide	Double guide Guide rod diameter ø12mm Ball bush type
Rod Diameter	ø22mm
Non-rotating accuracy of rod	±0.05 deg
Ambient Operating Temp./Humidity	0 ~ 40°C, 85% RH or less (non-condensing)

Option List		
Name	Option Code	See Page
Brake	B	→ A-25
Foot bracket	FT	→ A-29
Reversed-home	NM	→ A-33

Dimensions

CAD drawings can be downloaded from IAI website. www.robocylinder.de



For Special Orders P. A-9

- *1. The motor-encoder cable is connected here. See page A-39 for details on cables.
- *2. When homing, the rod moves to the M.E.; therefore, please watch for any interference with the surrounding objects.
ME: Mechanical end
SE: Stroke end
The values enclosed in "() " are reference dimensions.
- *3. Please note that there is no T-slot on the bottom of the brake unit.

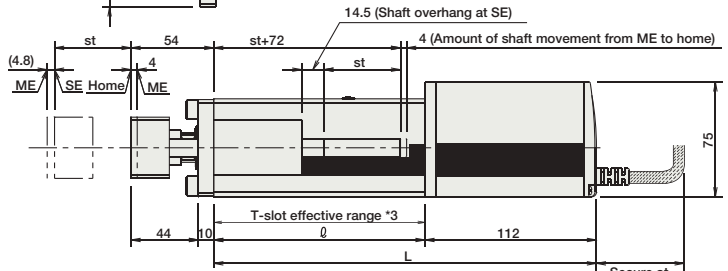
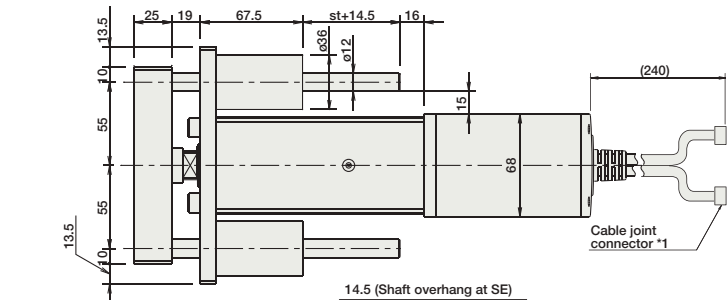
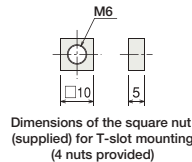
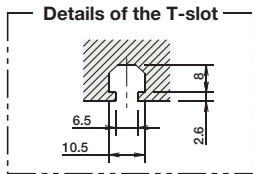
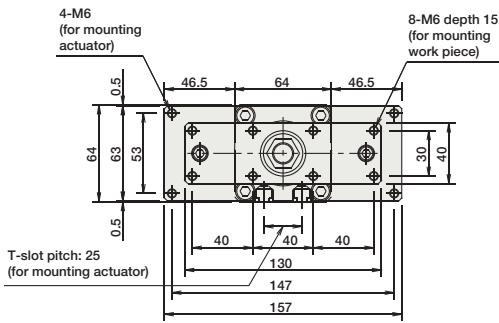

Brake-Equipped

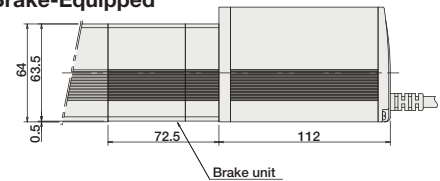

* Compared to the standard model, the brake-equipped model is longer by 72.5mm and heavier by 0.9kg.

■ Dimensions/Weight by Stroke

Stroke	50	100	150	200	250	300
ℓ	138	188	238	288	338	388
L	250	300	350	400	450	500
Weight (kg)	4.4	5.0	5.5	6.1	6.7	7.3

Compatible Controllers

The RCP2 series actuators can operate with the controllers below. Select the controller according to your usage.

Name	External View	Model	Description	Max. Positioning Points	Input Voltage	Power Supply Capacity	See Page
Solenoid Valve Type		PMEC-C-56PI-NP-2-2	Easy-to-use controller, even for beginners	3 points	AC115V AC230V	See P481	→ P477
		PSEP-C-56PI-NP-2-0	Operable with same signal as solenoid valve. Supports both single and double solenoid types. No homing necessary with simple absolute type.				→ P487
Splash-Proof Solenoid Valve Type		PSEP-CW-56PI-NP-2-0					
Positioner Type		PCON-C-56PI-NP-2-0	Positioning is possible for up to 512 points	512 points	DC24V	2A max.	
Safety-Compliant Positioner Type		PCON-CG-56PI-NP-2-0					
Pulse Train Input Type (Differential Line Driver)		PCON-PL-56PI-NP-2-0	Pulse train input type with differential line driver support	(-)	DC24V	2A max.	→ P525
Pulse Train Input Type (Open Collector)		PCON-PO-56PI-NP-2-0	Pulse train input type with open collector support				
Serial Communication Type		PCON-SE-56PI-N-0-0	Dedicated to serial communication	64 points			
Field Network Type		RPCON-56P	Dedicated to field network	768 points			→ P503
Program Control Type		PSEL-C-1-56PI-NP-2-0	Programmed operation is possible. Operation is possible on up to 2 axes	1500 points			→ P557

* This is for the single-axis PSEL.

- Slider Type
- Mini
- Standard
- Controllers Integrated
- Rod Type
- Mini
- Standard
- Controllers Integrated
- Table/Arm /Flat Type
- Mini
- Standard
- Gripper/ Rotary Type
- Linear Motor Type
- Cleanroom Type
- Splash Proof
- Controllers
- PMEC /AMEC
- PSEP /ASEP
- ROBO NET
- ERC2
- PCON
- ACON
- SCON
- PSEL
- ASEL
- SSEL
- XSEL
- Pulse Motor
- Servo Motor (24V)
- Servo Motor (230V)
- Linear Motor

RCP2-SRGD4R

RoboCylinder Short-Length Rod Type with Double Guide 45mm Width
Pulse Motor Side-Mounted Motor

■ Configuration: **RCP2 -SRGD4R - I - 35P** - [] - [] - [] - [] - []

Series	Type	Encoder	Motor	Lead	Stroke	Compatible Controllers	Cable Length	Option
I: Incremental * The Simple absolute encoder is also considered type "I".	35P: Pulse motor 35 □ size	5 : 5mm 2.5 : 2.5mm	20: 20mm 200: 200mm (10mm pitch increments) * Set in 50mm increments over 100mm	P1: PCON RPCON PSEL P3: PMEC PSEP	N : None P : 1m S : 3m M : 5m X □ □ : Custom	See Options below		

* See page Pre-35 for an explanation of the naming convention.



Technical References P. A-5

- POINT** Notes on Selection
- Since the RCP2 series use a pulse motor, the load capacity decreases at high speeds. Check in the Speed vs. Load Capacity graph to see if your desired speed and load capacity are supported.
 - The load capacity is based on operation at an acceleration of 0.3G (0.2G for the 2.5mm-lead model, or when used vertically). This is the upper limit of the acceleration.
 - The horizontal load capacity is based on the use of an external guide. See the technical resources (page A-83) for the allowable weight using the supplied guide alone.

■ Speed vs. Load Capacity
Due to the characteristics of the pulse motor, the RCP2 series' load capacity decreases at high speeds. In the table below, check if your desired speed and load capacity are supported.

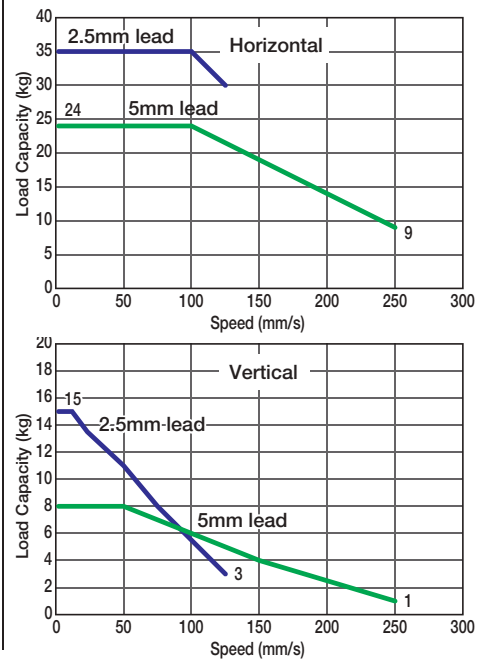

Actuator Specifications						Stroke and Maximum Speed	
■ Lead and Load Capacity						20 ~ 200 (10mm increments)	
Model	Lead (mm)	Max. Load Capacity (Note 1)		Maximum Push Force (N)(Note 2)	Stroke (mm)	Stroke	20 ~ 200 (10mm increments)
RCP2-SRGD4R-I-35P-5-①-②-③-④	5	Horizontal (kg)	Vertical (kg)	90	20~200 (10mm increments) (Note 3)	Lead	250
RCP2-SRGD4R-I-35P-2.5-①-②-③-④	2.5	~ 24	~ 8	170		5	250
		~ 35	~ 15			2.5	125

Legend: ① Stroke ② Compatible controller ③ Cable length ④ Options

(Note 1) Please note that the maximum load capacity decreases as the speed increases.
(Note 2) See page A-69 for the pushing force graphs.
(Note 3) 50mm increments over 100mm. (Unit: mm/s)

Type	Cable Symbol
Standard (Robot Cables)	P (1m)
	S (3m)
	M (5m)
Special Lengths	X06 (6m) ~ X10 (10m)
	X11 (11m) ~ X15 (15m)
	X16 (16m) ~ X20 (20m)

* The cable is a motor-encoder integrated cable, and is provided as a robot cable.
* See page A-39 for cables for maintenance.

Item	Description
Drive System	Ball screw ø8mm C10 grade
Positioning Repeatability	±0.02mm
Lost Motion	0.1mm or less
Rod Diameter	ø22mm
Non-rotating accuracy of rod	±0.05 deg
Ambient Operating Temp./Humidity	0 ~ 40°C, 85% RH or less (non-condensing)

Name	Option Code	See Page
Brake	B	→ A-25
Foot bracket 1 (base mounting)	FT	→ A-29
Reversed-home	NM	→ A-33

* The brake can be used for strokes of 70mm or more.
* The foot bracket cannot be mounted on the side.

Dimensions

CAD drawings can be downloaded from IAI website. www.robocylinder.de

For Special Orders P. A-9

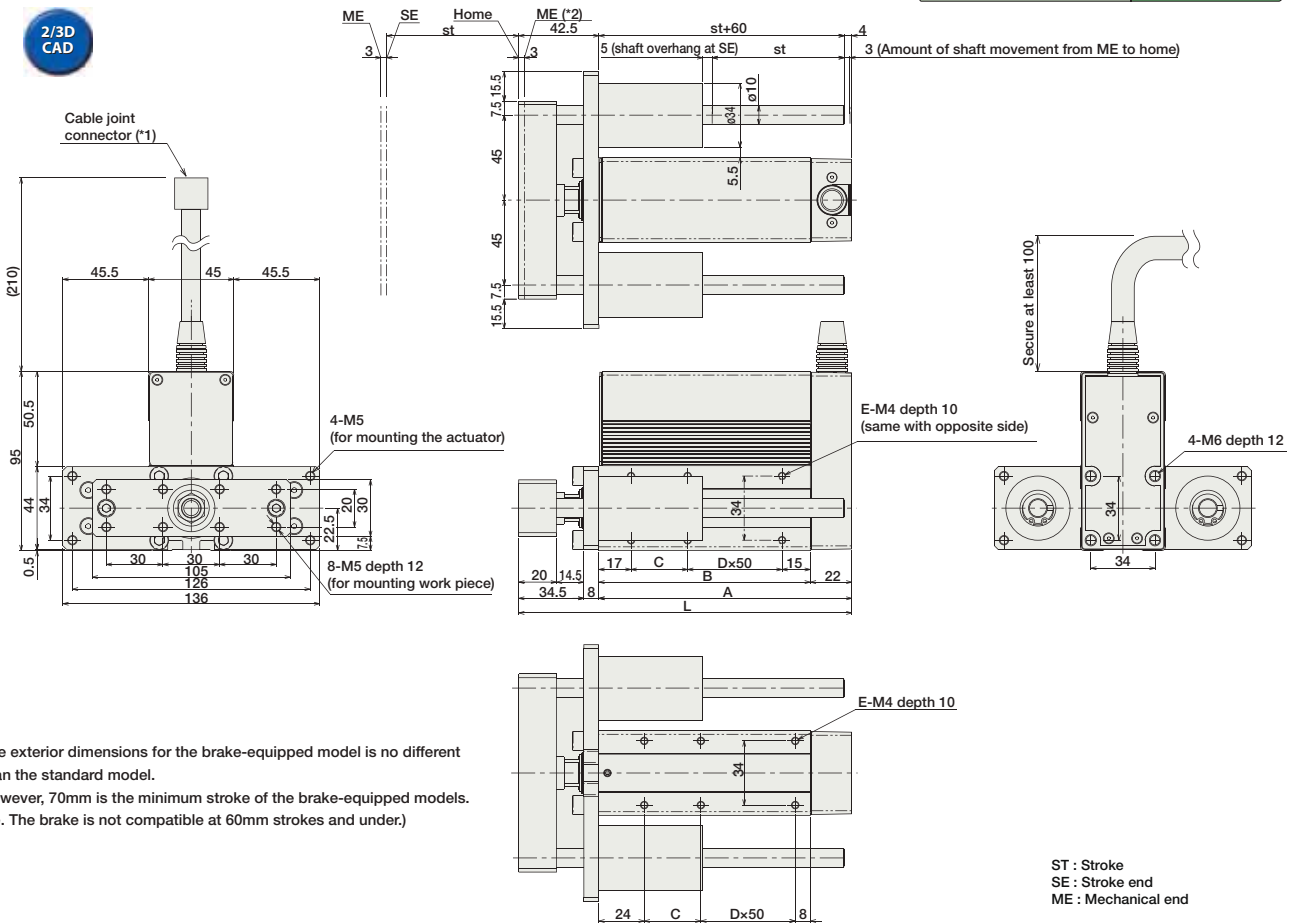

* The exterior dimensions for the brake-equipped model is no different than the standard model.
However, 70mm is the minimum stroke of the brake-equipped models. (i.e. The brake is not compatible at 60mm strokes and under)

(*1) The motor-encoder cable is connected here. See page A-39 for details on cables.
(*2) When homing, the rod moves to the mechanical end position; therefore, please watch for any interference with the surrounding objects.

Dimensions/Weight by Stroke (+0.2kg with brake)

Stroke	20	30	40	50	60	70	80	90	100	150	200
L	126.5	136.5	146.5	156.5	166.5	176.5	186.5	196.5	206.5	256.5	306.5
A	84	94	104	114	124	134	144	154	164	214	264
B	62	72	82	92	102	112	122	132	142	192	242
C	30	40	50	60	70	80	90	100	110	160	210
D	0	0	0	0	0	1	1	1	1	2	3
E	4	4	4	4	4	6	6	6	6	8	10
Weight (kg)	1.47	1.55	1.62	1.7	1.77	1.84	1.92	1.99	2.07	2.44	2.81

Compatible Controllers

The RCP2 series actuators can operate with the controllers below. Select the controller according to your usage.

Name	External View	Model	Description	Max. Positioning Points	Input Voltage	Power Supply Capacity	See Page
Solenoid Valve Type		PMEC-C-35PI-NP-2-2	Easy-to-use controller, even for beginners	3 points	AC115V AC230V	See P481	→ P477
		PSEP-C-35PI-NP-2-0	Operable with same signal as solenoid valve. Supports both single and double solenoid types. No homing necessary with simple absolute type.				
Splash-Proof Solenoid Valve Type		PSEP-CW-35PI-NP-2-0					
Positioner Type		PCON-C-35PI-NP-2-0	Positioning is possible for up to 512 points	512 points			
Safety-Compliant Positioner Type		PCON-CG-35PI-NP-2-0					
Pulse Train Input Type (Differential Line Driver)		PCON-PL-35PI-NP-2-0	Pulse train input type with differential line driver support	(-)	DC24V	2A max.	→ P525
Pulse Train Input Type (Open Collector)		PCON-PO-35PI-NP-2-0	Pulse train input type with open collector support				
Serial Communication Type		PCON-SE-35PI-N-0-0	Dedicated to serial communication	64 points			
Field Network Type		RPCON-35P	Dedicated to field network	768 points			→ P503
Program Control Type		PSEL-C-1-35PI-NP-2-0	Programmed operation is possible. Operation is possible on up to 2 axes	1500 points			→ P557

* This is for the single-axis PSEL.

- Slider Type
- Mini
- Standard
- Controllers Integrated
- Rod Type
- Mini
- Standard
- Controllers Integrated
- Table/Arm /Flat Type
- Mini
- Standard
- Gripper/ Rotary Type
- Linear Motor Type
- Cleanroom Type
- Splash Proof
- Controllers
- PMEC /AMEC
- PSEP /ASEP
- ROBO NET
- ERC2
- PCON
- ACON
- SCON
- PSEL
- ASEL
- SSEL
- XSEL
- Pulse Motor
- Servo Motor (24V)
- Servo Motor (230V)
- Linear Motor

RCP3-TA3C

RoboCylinder Mini Table Type Motor Unit Coupled 36mm Width Pulse Motor Ball Screw

■ Configuration: **RCP3** — **TA3C** — **I** — **20P** — — — — —

Series — Type — Encoder — Motor — Lead — Stroke — Compatible Controllers — Cable Length — Option

I: Incremental
* The simple absolute encoder is also considered type "I".

20P: Pulse motor
20 size

6: 6mm
4: 4mm
2: 2mm

20: 20mm
100: 100mm (10mm pitch increments)

P1: PCON
RPCON
PSEL
P3: PMEC
PSEP

N: None
P: 1m
S: 3m
M: 5m

See Options below
X : Custom

* See page Pre-35 for an explanation of the naming convention.



Technical References P. A-5

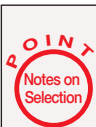

(1) The load capacity is based on operation at an acceleration of 0.3G (0.2G for the 2mm-lead model, or when used vertically). 0.3G (0.2G for 2mm lead) is the upper limit of the acceleration.

Speed vs. Load Capacity

Due to the characteristics of the Pulse motor, the RCP3 series' load capacity decreases at high speeds. In the table below, check if your desired speed and load capacity are supported.

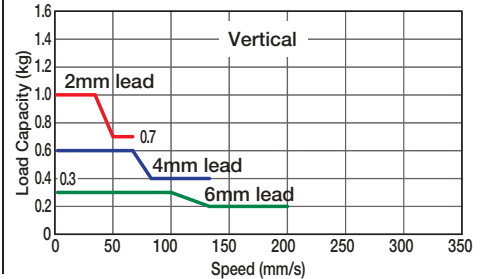
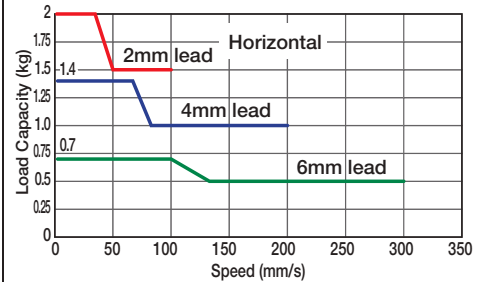

Actuator Specifications

Lead and Load Capacity

(Note 1) Please note that the maximum load capacity decreases as the speed increases.

Model	Feed Screw	Lead (mm)	Max. Load Capacity (Note 1)		Maximum Push Force (N) (Note 2)	Positioning Repeatability (mm)	Stroke (mm)
			Horizontal (kg)	Vertical (kg)			
RCP3-TA3C-I-20P-6-①-②-③-④	Ball Screw	6	~ 0.7	~ 0.3	9	±0.02	20~100 (10mm increments)
RCP3-TA3C-I-20P-4-①-②-③-④		4	~ 1.4	~ 0.6	14		
RCP3-TA3C-I-20P-2-①-②-③-④		2	~ 2	~ 1	28		

Legend ① Stroke ② Compatible controller ③ Cable length ④ Options

(Note 2) See page A-66 for pushing force graphs.

Stroke and Maximum Speed

Lead	Stroke (mm)	
	20 ~ 100 (mm)	200 ~ 300 (mm)
Ball Screw	6	300 <200>
	4	200 <133>
	2	100 <67>

* The values enclosed in "<" ">" apply to vertical usage. (Unit: mm/s)

Cable List

Type	Cable Symbol
Standard (Robot Cables)	P (1m)
	S (3m)
	M (5m)
Special Lengths	X06 (6m) ~ X10 (10m)
	X11 (11m) ~ X15 (15m)
	X16 (16m) ~ X20 (20m)

* The RCP3 comes standard with a robot cable.

* See page A-39 for cables for maintenance.

Actuator Specifications

Item	Description
Drive System	Ball screw ø6mm C10 grade
Lost Motion	0.1mm or less
Base	Material: Aluminum (white alumite treated)
Allowable Dynamic Moment (Note 3)	Ma: 3.2 N·m Mb: 4.6 N·m Mc: 5.1 N·m
Ambient Operating Temp./Humidity	0~40°C, 85% RH or less (non-condensing)

(Note 3) Based on a 5,000km service life.

Directions of Allowable Load Moments

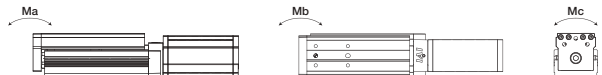

Option List

Name	Option Code	See Page
Brake	B	→ A-25
Reversed-home	NM	→ A-33

Dimensions

CAD drawings can be downloaded from IAI website. www.robocylinder.de

For Special Orders P. A-9

2/3D CAD

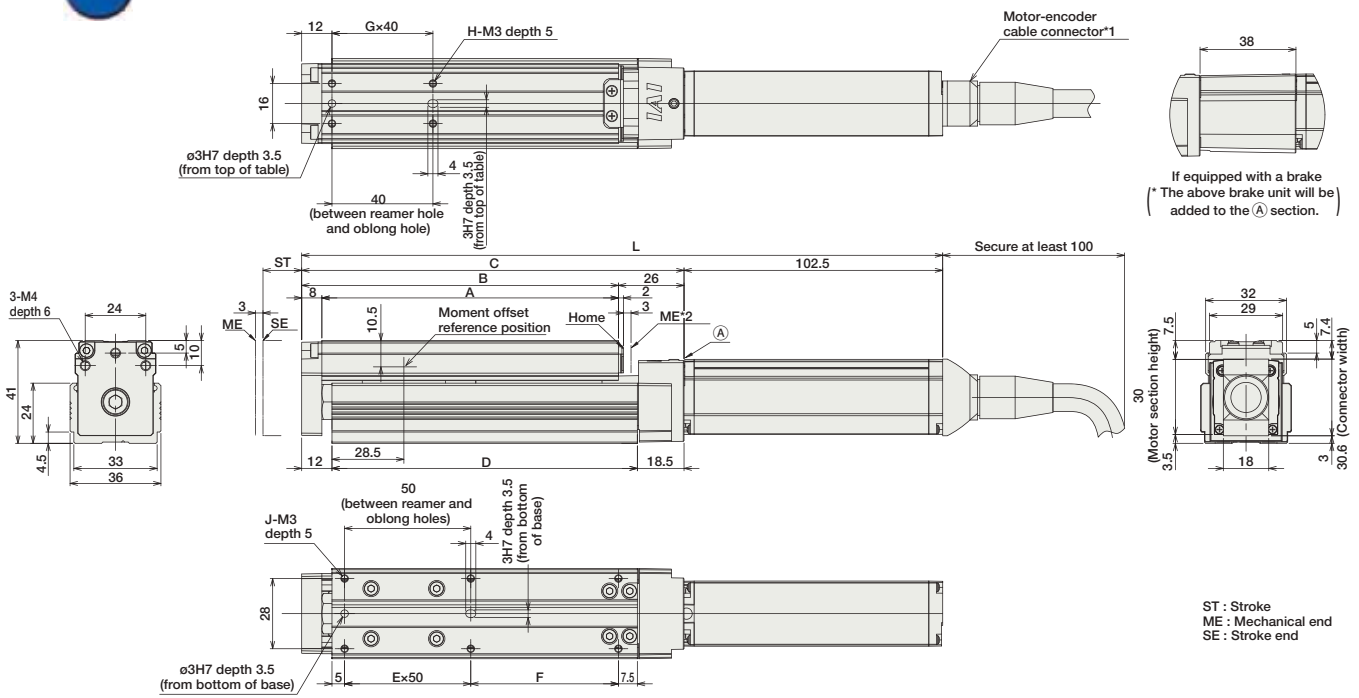

- *1 The motor-encoder cable is connected directly to the motor cover of the actuator. See page A-39 for details on cables.
- *2 When homing, the slider moves to the mechanical end; therefore, please watch for any interference with the surrounding objects.

Dimensions/Weight by Stroke * Adding a brake will increase the actuator's weight by 0.1kg.

Stroke	20	30	40	50	60	70	80	90	100	
L	No Brake	224	234	244	254	264	274	284	294	304
	Brake-equipped	262	272	282	292	302	312	322	332	342
A	87.5	97.5	107.5	117.5	127.5	137.5	147.5	157.5	167.5	
B	95.5	105.5	115.5	125.5	135.5	145.5	155.5	165.5	175.5	
C	121.5	131.5	141.5	151.5	161.5	171.5	181.5	191.5	201.5	
D	91	101	111	121	131	141	151	161	171	
E	1	1	1	1	2	2	2	2	2	
F	28.5	38.5	48.5	58.5	68.5	78.5	88.5	98.5	108.5	
G	1	1	1	1	2	2	2	2	2	
H	4	4	4	4	6	6	6	6	6	
J	6	6	6	6	8	8	8	8	8	
Weight (kg)	0.5	0.5	0.5	0.6	0.6	0.6	0.6	0.7	0.7	

Compatible Controllers

The RCP3 series actuators can operate with the controllers below. Select the controller according to your usage.

Name	External View	Model	Description	Max. Positioning Points	Input Voltage	Power Supply Capacity	See Page
Solenoid Valve Type		PMEC-C-20PI-NP-2-2	Easy-to-use controller, even for beginners	3 points	AC115V AC230V	See P481	→ P477
	Splash-Proof Solenoid Valve Type		PSEP-C-20PI-NP-2-0				
Positioner Type			PCON-C-20PI-NP-2-0	Positioning is possible for up to 512 points	512 points		
	Safety-Compliant Positioner Type		PCON-CG-20PI-NP-2-0				
Pulse Train Input Type (Differential Line Driver)		PCON-PL-20PI-NP-2-0	Pulse train input type with differential line driver support	(-)	DC24V	2A max.	→ P625
Pulse Train Input Type (Open Collector)		PCON-PO-20PI-NP-2-0	Pulse train input type with open collector support				
Serial Communication Type		PCON-SE-20PI-N-0-0	Dedicated to serial communication	64 points			
Field Network Type		RCON-20P	Dedicated to field network	768 points			→ P503
Program Control Type		PSEL-C-1-20PI-NP-2-0	Programmed operation is possible. Operation is possible on up to 2 axes	1500 points			→ P557

* This is for the single-axis PSEL.

- Slider Type
- Mini
- Standard
- Controllers Integrated
- Rod Type
- Mini
- Standard
- Controllers Integrated
- Table/Arm /Flat Type
- Mini
- Standard
- Gripper/ Rotary Type
- Linear Motor Type
- Cleanroom Type
- Splash Proof
- Controllers
- PMEC /AMEC
- PSEP /ASEP
- ROBO NET
- ERC2
- PCON
- ACON
- SCON
- PSEL
- ASEL
- SSEL
- XSEL
- Pulse Motor
- Servo Motor (24V)
- Servo Motor (230V)
- Linear Motor

- Slider Type
- Mini
- Standard
- Controllers Integrated
- Rod Type
- Mini
- Standard
- Controllers Integrated
- Table/Arm /Flat Type
- Mini
- Standard
- Gripper/ Rotary Type
- Linear Motor Type
- Cleanroom Type
- Splash Proof
- Controllers
- PMEC /AMEC
- PSEP /ASEP
- ROBO NET
- ERC2
- PCON
- ACON
- SCON
- PSEL
- ASEL
- SSEL
- XSEL
- Pulse Motor
- Servo Motor (24V)
- Servo Motor (230V)
- Linear Motor

RCP3-TA4C RoboCylinder Mini Table Type Motor Unit Coupled 40mm Width Pulse Motor Ball Screw

■ Configuration: **RCP3** — **TA4C** — **I** — **28P** — — — — —

Series — Type — Encoder — Motor — Lead — Stroke — Compatible Controllers — Cable Length — Option

I: Incremental
* The simple absolute encoder is also considered type "I".

28P: Pulse motor
28 □ size

6: 6mm
4: 4mm
2: 2mm

20: 20mm
↓
100: 100mm (10mm pitch increments)

P1: PCON
RPCON
PSEL
P3: PMEAC
PSEP

N: None
P: 1m
S: 3m
M: 5m

See Options below
X □ □ : Custom

* See page Pre-35 for an explanation of the naming convention.



Technical References P. A-5

POINT
Notes on Selection

(1) The load capacity is based on operation at an acceleration of 0.3G (0.2G for the 2mm-lead model, or when used vertically). 0.3G (0.2G for 2mm lead) is the upper limit of the acceleration.

■ Speed vs. Load Capacity
Due to the characteristics of the Pulse motor, the RCP3 series' load capacity decreases at high speeds. In the table below, check if your desired speed and load capacity are supported.

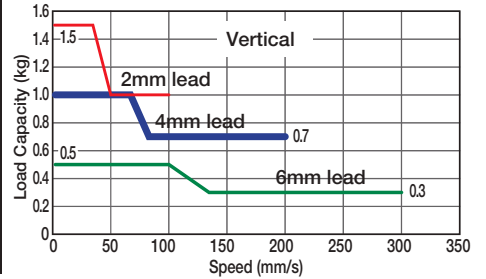
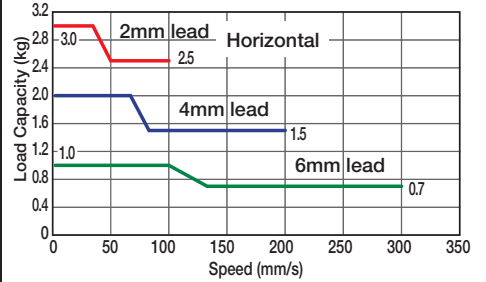

Actuator Specifications

Lead and Load Capacity

(Note 1) Please note that the maximum load capacity decreases as the speed increases.

Model	Feed Screw	Lead (mm)	Max. Load Capacity (Note 1)		Maximum Push Force (N) (Note 2)	Positioning Repeatability (mm)	Stroke (mm)
			Horizontal (kg)	Vertical (kg)			
RCP3-TA4C-I-28P-6-①-②-③-④	Ball Screw	6	~ 1	~ 0.5	15	±0.02	20~100 (10mm increments)
RCP3-TA4C-I-28P-4-①-②-③-④		4	~ 2	~ 1	22		
RCP3-TA4C-I-28P-2-①-②-③-④		2	~ 3	~ 1.5	44		

Legend ① Stroke ② Compatible controller ③ Cable length ④ Options

(Note 2) See page A-66 for pushing force graphs.

Stroke and Maximum Speed

Lead	Stroke	
	20 ~ 100 (mm)	200 ~ 300 (mm)
6	300	300
4	200	200
2	100	100

(Unit: mm/s)

Cable List

Type	Cable Symbol
Standard (Robot Cables)	P (1m)
	S (3m)
	M (5m)
Special Lengths	X06 (6m) ~ X10 (10m)
	X11 (11m) ~ X15 (15m)
	X16 (16m) ~ X20 (20m)

* The RCP3 comes standard with a robot cable.
* See page A-39 for cables for maintenance.

Actuator Specifications

Item	Description
Drive System	Ball screw ø6mm C10 grade
Lost Motion	0.1mm or less
Base	Material: Aluminum (white alumite treated)
Allowable Dynamic Moment (Note 3)	Ma: 4.2 N·m Mb: 6 N·m Mc: 8.2 N·m
Ambient Operating Temp./Humidity	0~40°C, 85% RH or less (non-condensing)

(Note 3) Based on a 5,000km service life.

Directions of Allowable Load Moments

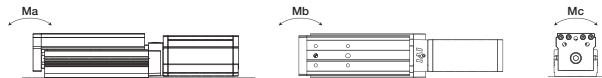

Option List

Name	Option Code	See Page
Brake	B	→ A-25
Cable exit direction (Top)	CJT	→ A-25
Cable exit direction (Right)	CJR	
Cable exit direction (Left)	CJL	
Cable exit direction (Bottom)	CJB	
Reversed-home	NM	→ A-33

Dimensions

CAD drawings can be downloaded from IAI website. www.robocylinder.de



For Special Orders P. A-9

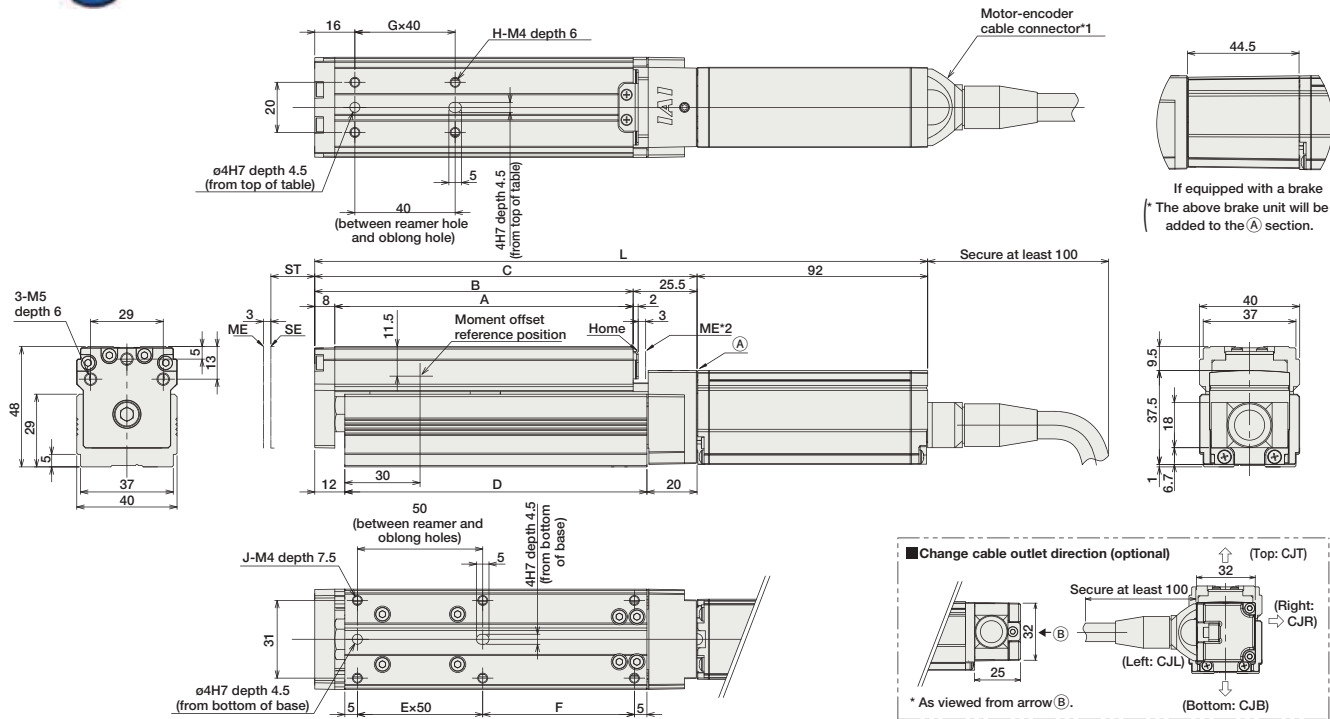

- *1 The motor-encoder cable is connected directly to the motor cover of the actuator. See page A-39 for details on cables.
 - *2 When homing, the slider moves to the mechanical end; therefore, please watch for any interference with the surrounding objects.
- ST : Stroke
ME : Mechanical end
SE : Stroke end

■ Dimensions/Weight by Stroke * Adding a brake will increase the actuator's weight by 0.2kg.

Stroke	20	30	40	50	60	70	80	90	100	
L	No Brake	214.5	224.5	234.5	244.5	254.5	264.5	274.5	284.5	294.5
	Brake-equipped	259	269	279	289	299	309	319	329	339
A	89	99	109	119	129	139	149	159	169	
B	97	107	117	127	137	147	157	167	177	
C	122.5	132.5	142.5	152.5	162.5	172.5	182.5	192.5	202.5	
D	90.5	100.5	110.5	120.5	130.5	140.5	150.5	160.5	170.5	
E	1	1	1	1	2	2	2	2	2	
F	30.5	40.5	50.5	60.5	20.5	30.5	40.5	50.5	60.5	
G	1	1	1	1	2	2	2	2	2	
H	4	4	4	4	6	6	6	6	6	
J	6	6	6	6	8	8	8	8	8	
Weight (kg)	0.7	0.7	0.7	0.8	0.8	0.8	0.9	0.9	0.9	

Compatible Controllers

The RCP3 series actuators can operate with the controllers below. Select the controller according to your usage.

Name	External View	Model	Description	Max. Positioning Points	Input Voltage	Power Supply Capacity	See Page
Solenoid Valve Type		PMEC-C-28PI-NP-2-2	Easy-to-use controller, even for beginners	3 points	AC115V AC230V	See P481	→ P477
		PSEP-C-28PI-NP-2-0	Operable with same signal as solenoid valve. Supports both single and double solenoid types. No homing necessary with simple absolute type.				
Splash-Proof Solenoid Valve Type		PSEP-CW-28PI-NP-2-0					
Positioner Type		PCON-C-28PI-NP-2-0	Positioning is possible for up to 512 points	512 points	DC24V	2A max.	→ P525
Safety-Compliant Positioner Type		PCON-CG-28PI-NP-2-0					
Pulse Train Input Type (Differential Line Driver)		PCON-PL-28PI-NP-2-0	Pulse train input type with differential line driver support	(-)	DC24V	2A max.	→ P525
Pulse Train Input Type (Open Collector)		PCON-PO-28PI-NP-2-0	Pulse train input type with open collector support				
Serial Communication Type		PCON-SE-28PI-N-0-0	Dedicated to serial communication	64 points			
Field Network Type		RPCON-28P	Dedicated to field network	768 points			→ P503
Program Control Type		PSEL-C-1-28PI-NP-2-0	Programmed operation is possible. Operation is possible on up to 2 axes	1500 points			→ P557

* This is for the single-axis PSEL.

- Slider Type
- Mini
- Standard
- Controllers Integrated
- Rod Type
- Mini
- Standard
- Controllers Integrated
- Table/Arm /Flat Type
- Mini
- Standard
- Controllers Integrated
- Gripper/ Rotary Type
- Linear Motor Type
- Cleanroom Type
- Splash Proof
- Controllers
- PMEC /AMEC
- PSEP /ASEP
- ROBO NET
- ERC2
- PCON
- ACON
- SCON
- PSEL
- ASEL
- SSEL
- XSEL
- Pulse Motor
- Servo Motor (24V)
- Servo Motor (230V)
- Linear Motor

- Slider Type
- Mini
- Standard
- Controllers Integrated
- Rod Type
- Mini
- Standard
- Controllers Integrated
- Table/Arm /Flat Type
- Mini
- Standard
- Gripper/ Rotary Type
- Linear Motor Type
- Cleanroom Type
- Splash Proof
- Controllers
- PMEC /AMEC
- PSEP /ASEP
- ROBO NET
- ERC2
- PCON
- ACON
- SCON
- PSEL
- ASEL
- SSEL
- XSEL
- Pulse Motor
- Servo Motor (24V)
- Servo Motor (230V)
- Linear Motor

RCP3-TA5C

RoboCylinder Table Type Motor Unit Coupled 55mm Width Pulse Motor Ball Screw

■ Configuration: **RCP3-TA5C-I-35P** - [] - [] - [] - [] - []

Series - Type - Encoder - Motor - Lead - Stroke - Compatible Controllers - Cable Length - Option

I: Incremental 35P: Pulse motor 10: 10mm 25: 25mm P1: PCON N : None See Options below
 * The simple absolute encoder is also considered type "I". 35 [] size 5: 5mm 100: 100mm (25mm pitch increments) RPCON P : 1m
 P3: PMEC S : 3m PSEP M : 5m X [] : Custom

* See page Pre-35 for an explanation of the naming convention.

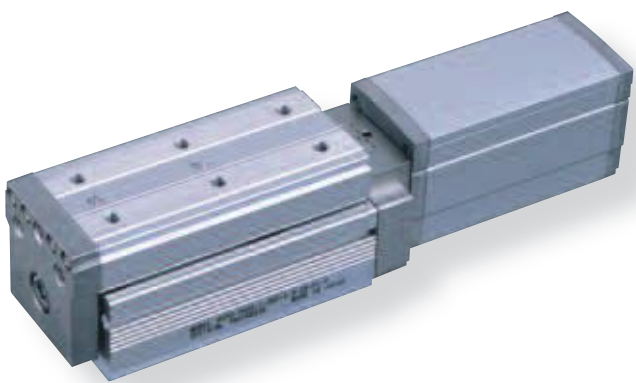

Technical References P. A-5

- POINT** Notes on Selection
- (1) Since the RCP3 series use a pulse motor, the load capacity decreases at high speeds. Check in the Speed vs. Load Capacity graph to see if your desired speed and load capacity are supported.
 - (2) Please note that the maximum speed is different when used horizontally versus vertically.
 - (3) The load capacity is based on operation at an acceleration of 0.3G (0.2G for the 2.5mm-lead model, or when used vertically). This is the upper limit of the acceleration.

■ Speed vs. Load Capacity
 Due to the characteristics of the Pulse motor, the RCP3 series' load capacity decreases at high speeds. In the table below, check if your desired speed and load capacity are supported.

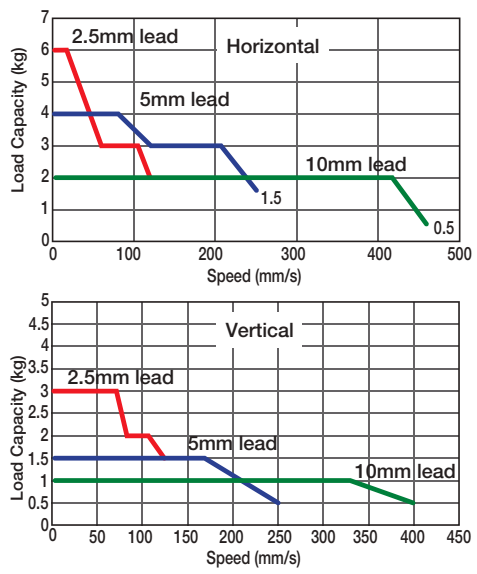

Actuator Specifications					
■ Lead and Load Capacity			(Note 1) Please note that the maximum load capacity decreases as the speed increases.		
Model	Lead (mm)	Max. Load Capacity (Note 1)		Maximum Push Force (N) (Note 2)	Stroke (mm)
		Horizontal (kg)	Vertical (kg)		
RCP3-TA5C-I-35P-10-①-②-③-④	10	~ 2	~ 1	34	25~100 (25mm increments)
RCP3-TA5C-I-35P-5-①-②-③-④	5	~ 4	~ 1.5	68	
RCP3-TA5C-I-35P-2.5-①-②-③-④	2.5	~ 6	~ 3	136	

■ Stroke and Maximum Speed	
Stroke / Lead	25 ~ 100 (25mm increments)
10	465 <400>
5	250
2.5	125

Legend ① Stroke ② Compatible controller ③ Cable length ④ Options (Note 2) See page A-66 for pushing force graphs. (Unit: mm/s)

Cable List

Type	Cable Symbol
Standard (Robot Cables)	P (1m)
	S (3m)
	M (5m)
Special Lengths	X06 (6m) ~ X10 (10m)
	X11 (11m) ~ X15 (15m)
	X16 (16m) ~ X20 (20m)

* The standard cable is the motor-encoder integrated robot cable.
 * See page A-39 for cables for maintenance.

Actuator Specifications

Item	Description
Drive System	Ball screw ø8mm C10 grade
Positioning Repeatability	±0.02mm
Lost Motion	0.1mm or less
Base	Material: Material: Aluminum (special alumite treated)
Allowable Static Moment	Ma: 25.5 N·m Mb: 36.5 N·m Mc: 56.1 N·m
Allowable Dynamic Moment (*)	Ma: 6.57 N·m Mb: 9.32 N·m Mc: 14.32 N·m
Overhang Load Length	Within the load moment range
Ambient Operating Temp./Humidity	0~40°C, 85% RH or less (non-condensing)

(*) Based on a 5,000km service life.

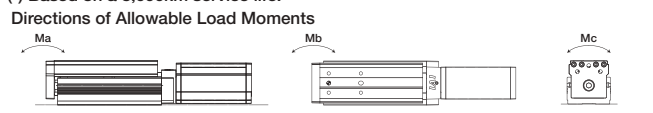

Option List

Name	Option Code	Standard Price
Brake	B	→ A-25
Cable exit direction (Top)	CJT	→ A-25
Cable exit direction (Right)	CJR	→ A-25
Cable exit direction (Left)	CJL	→ A-25
Cable exit direction (Bottom)	CJB	→ A-25
Reversed-home	NM	→ A-33

Dimensions

CAD drawings can be downloaded from IAI website. www.robocylinder.de

For Special Orders P. A-9

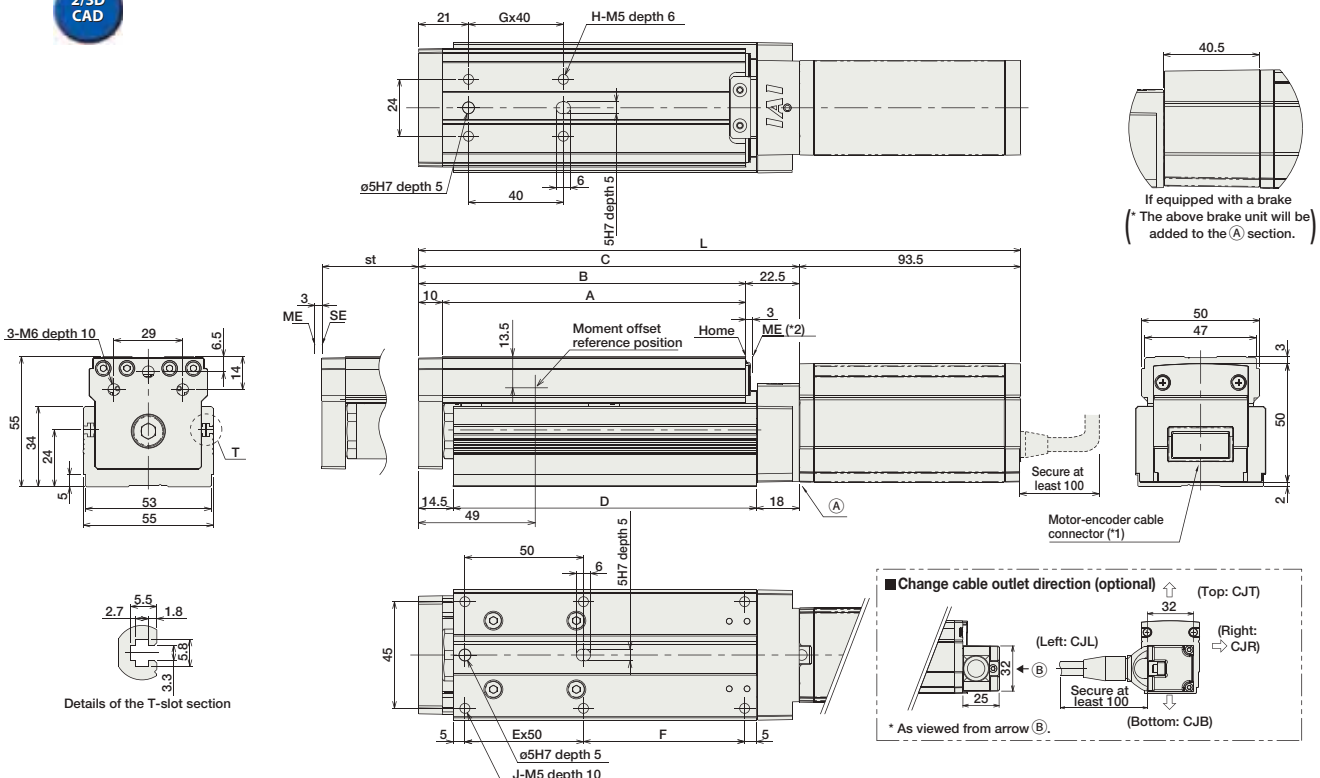

■ Dimensions/Weight by Stroke * Adding a brake will increase the actuator's weight by 0.3kg.

Stroke	Stroke				
	25	50	75	100	
L	No Brake	229	254	279	304
	Brake-Equipped	269.5	294.5	319.5	344.5
A	103	128	153	178	
B	113	138	163	188	
C	135.5	160.5	185.5	210.5	
D	103	128	153	178	
E	1	1	2	2	
F	43	68	43	68	
G	1	1	2	2	
H	4	4	6	6	
J	6	6	8	8	
Weight (kg)	1.2	1.4	1.5	1.7	

(*1) The motor-encoder cable (integrated) is connected. (See page A-39 for details on cables.)
 (*2) After homing, the slider moves to the ME; therefore, please watch for any interference with the surrounding objects.
 ME: Mechanical end
 SE: Stroke end

Compatible Controllers

The RCP3 series actuators can operate with the controllers below. Select the controller according to your usage.

Name	External View	Model	Description	Max. Positioning Points	Input Voltage	Power Supply Capacity	See Page
Solenoid Valve Type		PMEC-C-35PI-NP-2-2	Easy-to-use controller, even for beginners	3 points	AC115V AC230V	See P481	→ P477
		PSEP-C-35PI-NP-2-0	Operable with same signal as solenoid valve. Supports both single and double solenoid types. No homing necessary with simple absolute type.				
Splash-Proof Solenoid Valve Type		PSEP-CW-35PI-NP-2-0					
Positioner Type		PCON-C-35PI-NP-2-0	Positioning is possible for up to 512 points	512 points	DC24V	2A max.	
Safety-Compliant Positioner Type		PCON-CG-35PI-NP-2-0					
Pulse Train Input Type (Differential Line Driver)		PCON-PL-35PI-NP-2-0	Pulse train input type with differential line driver support	(-)			→ P525
Pulse Train Input Type (Open Collector)		PCON-PO-35PI-NP-2-0	Pulse train input type with open collector support				
Serial Communication Type		PCON-SE-35PI-N-0-0	Dedicated to serial communication	64 points			
Field Network Type		RPCON-35P	Dedicated to field network	768 points			→ P503
Program Control Type		PSEL-C-1-35PI-NP-2-0	Programmed operation is possible. Operation is possible on up to 2 axes	1500 points			→ P557

* This is for the single-axis PSEL.

- Slider Type
- Mini
- Standard
- Controllers Integrated
- Rod Type
- Mini
- Standard
- Controllers Integrated
- Table/Arm /Flat Type
- Mini
- Standard
- Gripper/ Rotary Type
- Linear Motor Type
- Cleanroom Type
- Splash Proof
- Controllers
- PMEC /AMEC
- PSEP /ASEP
- ROBO NET
- ERC2
- PCON
- ACON
- SCON
- PSEL
- ASEL
- SSEL
- XSEL
- Pulse Motor
- Servo Motor (24V)
- Servo Motor (230V)
- Linear Motor

- Slider Type
- Mini
- Standard
- Controllers Integrated
- Rod Type
- Mini
- Standard
- Controllers Integrated
- Table/Arm /Flat Type
- Mini
- Standard
- Gripper/ Rotary Type
- Linear Motor Type
- Cleanroom Type
- Splash Proof
- Controllers
- PMEC /AMEC
- PSEP /ASEP
- ROBO NET
- ERC2
- PCON
- ACON
- SCON
- PSEL
- ASEL
- SSEL
- XSEL
- Pulse Motor
- Servo Motor (24V)
- Servo Motor (230V)
- Linear Motor

RCP3-TA6C RoboCylinder Table Type Motor Unit Coupled 65mm Width Pulse Motor Ball Screw

■ Configuration: **RCP3-TA6C-I-42P** - [] - [] - [] - []

Series — Type — Encoder — Motor — Lead — Stroke — Compatible Controllers — Cable Length — Option

I: Incremental
* The simple absolute encoder is also considered type "I".

42P: Pulse motor
42 □ size

12 : 12mm
6 : 6mm
3 : 3mm

25: 25mm
150: 150mm (25mm pitch increments)

P1: PCON
RPCON
PSEL
P3: PMEAC
PSEP

N : None
P : 1m
S : 3m
M : 5m
X □ □ : Custom

See Options below

* See page Pre-35 for an explanation of the naming convention.

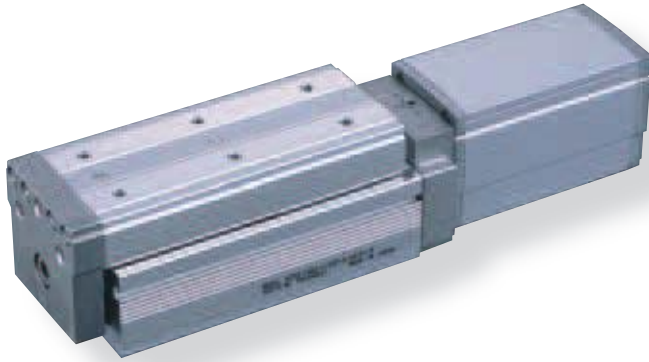

Technical References P. A-5

- POINT** Notes on Selection
- (1) Since the RCP3 series use a pulse motor, the load capacity decreases at high speeds. Check in the Speed vs. Load Capacity graph to see if your desired speed and load capacity are supported.
 - (2) Please note that the maximum speed is different when used horizontally versus vertically.
 - (3) The load capacity is based on operation at an acceleration of 0.3G (0.2G for the 3mm-lead model, or when used vertically). This is the upper limit of the acceleration.

■ Speed vs. Load Capacity
Due to the characteristics of the Pulse motor, the RCP3 series' load capacity decreases at high speeds. In the table below, check if your desired speed and load capacity are supported.

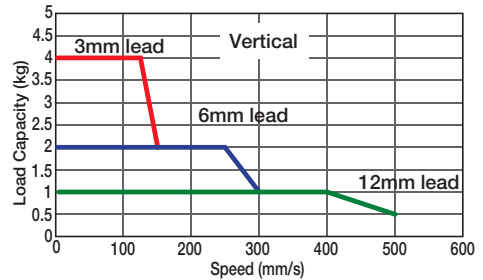
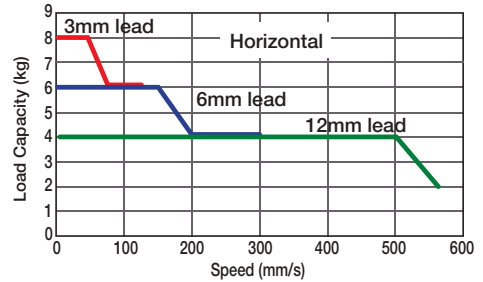

Actuator Specifications

Lead and Load Capacity

(Note 1) Please note that the maximum load capacity decreases as the speed increases.

Model	Lead (mm)	Max. Load Capacity (Note 1)		Maximum Push Force (N)(Note 2)	Stroke (mm)
		Horizontal (kg)	Vertical (kg)		
RCP3-TA6C-I-42P-12-①-②-③-④	12	~ 4	~ 1	47	25~150 (25mm increments)
RCP3-TA6C-I-42P-6-①-②-③-④	6	~ 6	~ 2	95	
RCP3-TA6C-I-42P-3-①-②-③-④	3	~ 8	~ 4	189	

Legend ① Stroke ② Compatible controller ③ Cable length ④ Options

(Note 2) See page A-66 for pushing force graphs.

Stroke and Maximum Speed

Lead	Stroke	25 ~ 150 (25mm increments)
		12
6	300	
3	150	

(Unit: mm/s)

Cable List

Type	Cable Symbol
Standard (Robot Cables)	P (1m)
	S (3m)
	M (5m)
Special Lengths	X06 (6m) ~ X10 (10m)
	X11 (11m) ~ X15 (15m)
	X16 (16m) ~ X20 (20m)

* The standard cable is the motor-encoder integrated robot cable.

* See page A-39 for cables for maintenance.

Actuator Specifications

Item	Description
Drive System	Ball screw ø10mm C10 grade
Positioning Repeatability	±0.02mm
Lost Motion	0.1mm or less
Base	Material: Material: Aluminum (special alumite treated)
Allowable Static Moment	Ma: 29.4 N·m Mb: 42.0 N·m Mc: 74.1 N·m
Allowable Dynamic Moment (*)	Ma: 7.26 N·m Mb: 10.3 N·m Mc: 18.25 N·m
Overhang Load Length	Within the load moment range
Ambient Operating Temp./Humidity	0~40°C, 85% RH or less (non-condensing)

(*) Based on a 5,000km service life.

Directions of Allowable Load Moments

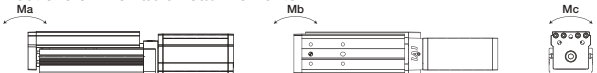

Option List

Name	Option Code	Standard Price
Brake	B	→ A-25
Cable exit direction (Top)	CJT	→ A-25
Cable exit direction (Right)	CJR	→ A-25
Cable exit direction (Left)	CJL	→ A-25
Cable exit direction (Bottom)	CJB	→ A-25
Reversed-home	NM	→ A-33

Dimensions

CAD drawings can be downloaded from IAI website. www.robocylinder.de



For Special Orders P. A-9

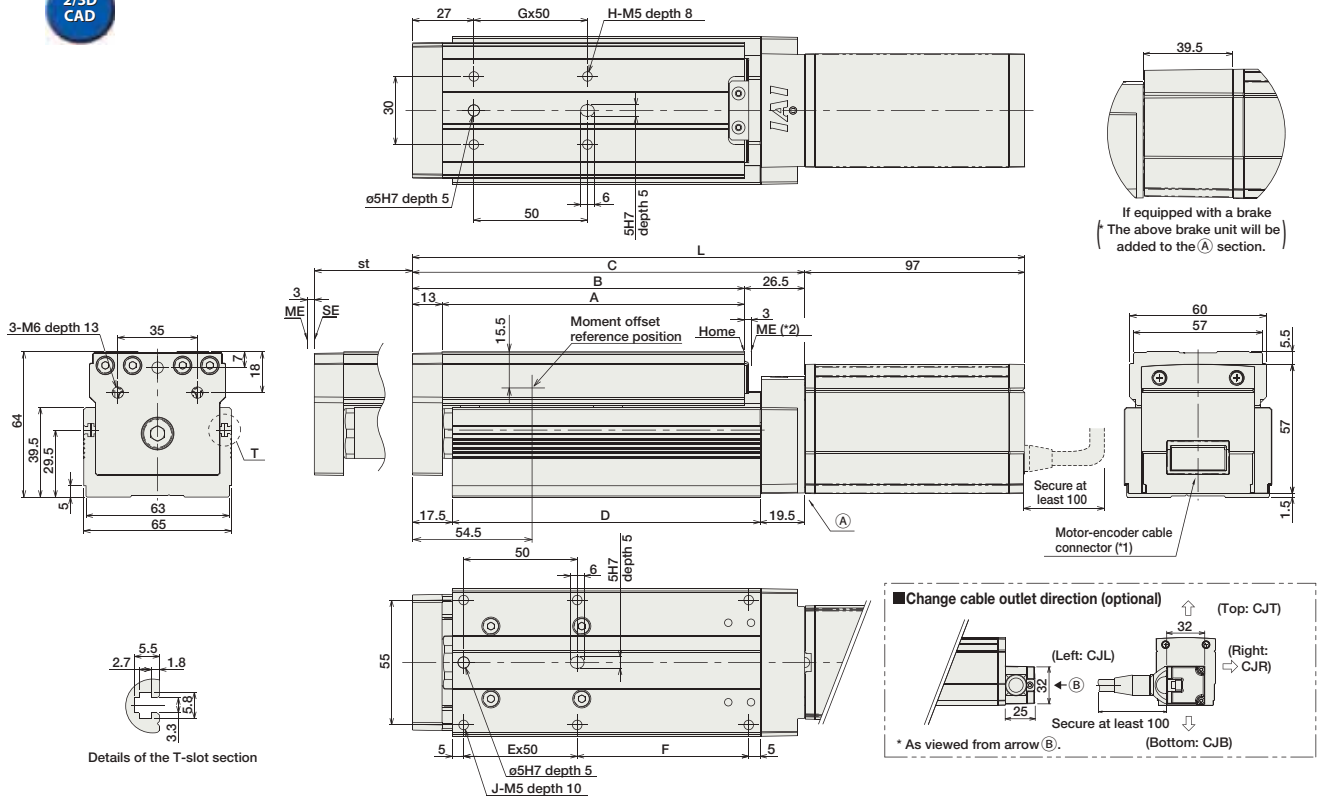

■ Dimensions/Weight by Stroke

* Adding a brake will increase the actuator's weight by 0.4kg.

Stroke	25	50	75	100	125	150	
							L
L	284	309	334	359	384	409	
A	108	133	158	183	208	233	
B	121	146	171	196	221	246	
C	147.5	172.5	197.5	222.5	247.5	272.5	
D	110.5	135.5	160.5	185.5	210.5	235.5	
E	1	1	2	2	3	3	
F	50.5	75.5	50.5	75.5	50.5	75.5	
G	1	1	2	2	3	3	
H	4	4	6	6	8	8	
J	6	6	8	8	10	10	
Weight (kg)	1.8	2	2.2	2.4	2.6	2.8	

(*1) The motor-encoder cable (integrated) is connected. (See page A-39 for details on cables.)
 (*2) After homing, the slider moves to the ME; therefore, please watch for any interference with the surrounding objects.
 ME: Mechanical end
 SE: Stroke end

Compatible Controllers

The RCP3 series actuators can operate with the controllers below. Select the controller according to your usage.

Name	External View	Model	Description	Max. Positioning Points	Input Voltage	Power Supply Capacity	See Page
Solenoid Valve Type		PMEC-C-42PI-NP-2-2	Easy-to-use controller, even for beginners	3 points	AC115V AC230V	See P481	→ P477
Splash-Proof Solenoid Valve Type		PSEP-C-42PI-NP-2-0 PSEP-CW-42PI-NP-2-0	Operable with same signal as solenoid valve. Supports both single and double solenoid types. No homing necessary with simple absolute type.				
Positioner Type		PCON-C-42PI-NP-2-0	Positioning is possible for up to 512 points	512 points	DC24V	2A max.	→ P525
Safety-Compliant Positioner Type		PCON-CG-42PI-NP-2-0					
Pulse Train Input Type (Differential Line Driver)		PCON-PL-42PI-NP-2-0	Pulse train input type with differential line driver support	(-)	DC24V	2A max.	→ P525
Pulse Train Input Type (Open Collector)		PCON-PO-42PI-NP-2-0	Pulse train input type with open collector support				
Serial Communication Type		PCON-SE-42PI-N-0-0	Dedicated to serial communication	64 points	DC24V	2A max.	→ P503
Field Network Type		RPCON-42P	Dedicated to field network	768 points			
Program Control Type		PSEL-C-1-42PI-NP-2-0	Programmed operation is possible. Operation is possible on up to 2 axes	1500 points	DC24V	2A max.	→ P557

* This is for the single-axis PSEL.

- Slider Type
- Mini
- Standard
- Controllers Integrated
- Rod Type
- Mini
- Standard
- Controllers Integrated
- Table/Arm /Flat Type
- Mini
- Standard
- Gripper/ Rotary Type
- Linear Motor Type
- Cleanroom Type
- Splash Proof
- Controllers
- PMEC /AMEC
- PSEP /ASEP
- ROBO NET
- ERC2
- PCON
- ACON
- SCON
- PSEL
- ASEL
- SSEL
- XSEL
- Pulse Motor
- Servo Motor (24V)
- Servo Motor (230V)
- Linear Motor

- Slider Type
- Mini
- Standard
- Controllers Integrated
- Rod Type
- Mini
- Standard
- Controllers Integrated
- Table/Arm /Flat Type
- Mini
- Standard
- Gripper/ Rotary Type
- Linear Motor Type
- Cleanroom Type
- Splash Proof
- Controllers
- PMEC /AMEC
- PSEP /ASEP
- ROBO NET
- ERC2
- PCON
- ACON
- SCON
- PSEL
- ASEL
- SSEL
- XSEL
- Pulse Motor
- Servo Motor (24V)
- Servo Motor (230V)
- Linear Motor

RCP3-TA7C RoboCylinder Table Type Motor Unit Coupled 75mm Width Pulse Motor Ball Screw

■ Configuration: **RCP3-TA7C-I-42P** - [] - [] - [] - []

Series — Type — Encoder — Motor — Lead — Stroke — Compatible Controllers — Cable Length — Option

I: Incremental
* The simple absolute encoder is also considered type "I".

42P: Pulse motor
42 [] size

12: 12mm
6: 6mm
3: 3mm

25: 25mm
200: 200mm (25mm pitch increments)

P1: PCON
RPCON
PSEL
P3: PMECC
PSEP

N : None
P : 1m
S : 3m
M : 5m
X [] : Custom

See Options below

* See page Pre-35 for an explanation of the naming convention.

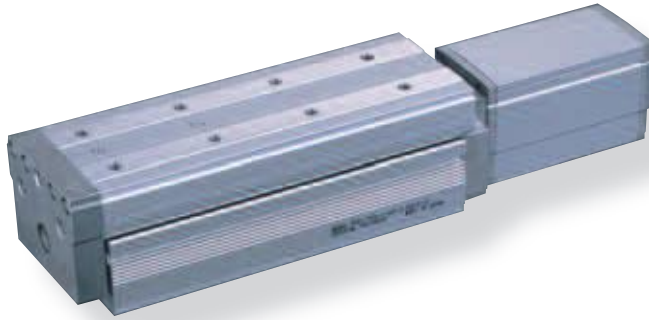

Technical References P. A-5

- POINT** Notes on Selection
- (1) Since the RCP3 series use a pulse motor, the load capacity decreases at high speeds. Check in the Speed vs. Load Capacity graph below to see if your desired speed and load capacity are supported.
 - (2) Please note that the maximum speed is different when used horizontally versus vertically.
 - (3) The load capacity is based on operation at an acceleration of 0.3G (0.2G for the 3mm-lead model, or when used vertically). This is the upper limit of the acceleration.

■ Speed vs. Load Capacity
Due to the characteristics of the Pulse motor, the RCP3 series' load capacity decreases at high speeds. In the table below, check if your desired speed and load capacity are supported.

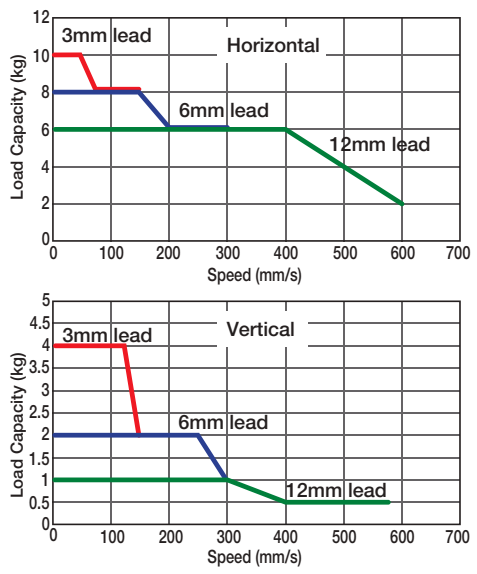

Actuator Specifications					
■ Lead and Load Capacity					Stroke and Maximum Speed
Model	Lead (mm)	Max. Load Capacity (Note 1)		Maximum Push Force (N) (Note 2)	Stroke (mm)
		Horizontal (kg)	Vertical (kg)		
RCP3-TA7C-I-42P-12-①-②-③-④	12	~ 6	~ 1	47	25~200 (25mm increments)
RCP3-TA7C-I-42P-6-①-②-③-④	6	~ 8	~ 2	95	
RCP3-TA7C-I-42P-3-①-②-③-④	3	~ 10	~ 4	189	

Lead	Stroke	
	25 ~ 200 (25mm increments)	
12	600 <580>	
6	300	
3	150	

Legend ① Stroke ② Compatible controller ③ Cable length ④ Options (Note 2) See page A-66 for pushing force graphs. (Unit: mm/s)

Cable List

Type	Cable Symbol
Standard (Robot Cables)	P (1m)
	S (3m)
	M (5m)
Special Lengths	X06 (6m) ~ X10 (10m)
	X11 (11m) ~ X15 (15m)
	X16 (16m) ~ X20 (20m)

* The standard cable is the motor-encoder integrated robot cable.
* See page A-39 for cables for maintenance.

Actuator Specifications

Item	Description
Drive System	Ball screw ø10mm C10 grade
Positioning Repeatability	±0.02mm
Lost Motion	0.1mm or less
Base	Material: Material: Aluminum (special alumite treated)
Allowable Static Moment	Ma: 42.6 N·m Mb: 60.8 N·m Mc: 123.2 N·m
Allowable Dynamic Moment (*)	Ma: 9.91 N·m Mb: 14.13 N·m Mc: 28.65 N·m
Overhang Load Length	Within the load moment range
Ambient Operating Temp./Humidity	0~40°C, 85% RH or less (non-condensing)

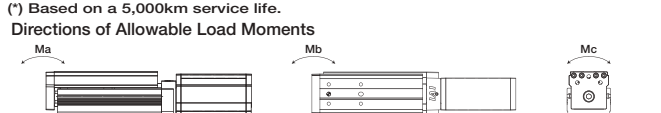

Option List

Name	Option Code	Standard Price
Brake	B	→ A-25
Cable exit direction (Top)	CJT	→ A-25
Cable exit direction (Right)	CJR	→ A-25
Cable exit direction (Left)	CJL	→ A-25
Cable exit direction (Bottom)	CJB	→ A-25
Reversed-home	NM	→ A-33

RCP3-TA3R

RoboCylinder Mini Table Type Side-Mounted Motor 36mm Width Pulse Motor Ball Screw

■ Configuration: **RCP3** — **TA3R** — **I** — **20P** — — — — —

Series	Type	Encoder	Motor	Lead	Stroke	Compatible Controllers	Cable Length	Option
I: Incremental * The simple absolute encoder is also considered type "I".	20P: Pulse motor 20 <input type="checkbox"/> size	6: 6mm 4: 4mm 2: 2mm	20: 20mm 100: 100mm (10mm pitch increments)	P1: PCON RPCON PSEL P3: PMEC PSEP	N: None P: 1m S: 3m M: 5m X <input type="checkbox"/> <input type="checkbox"/> : Custom	See Options below * Be sure to specify which side the motor is to be mounted (ML/MR).		

* See page Pre-35 for an explanation of the naming convention.

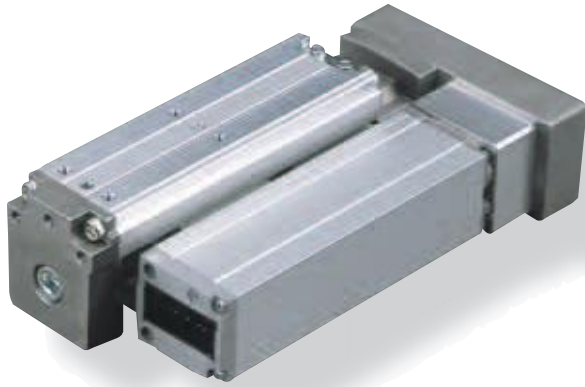

Pictured: Left-mounted motor model (ML).

Technical References P. A-5



(1) The load capacity is based on operation at an acceleration of 0.3G (0.2G for the 2mm-lead model, or when used vertically). 0.3G (0.2G for 2mm lead) is the upper limit of the acceleration.

Speed vs. Load Capacity

Due to the characteristics of the Pulse motor, the RCP3 series' load capacity decreases at high speeds. In the table below, check if your desired speed and load capacity are supported.

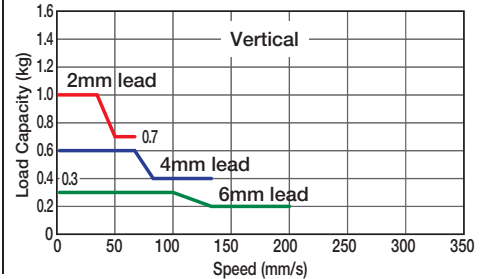
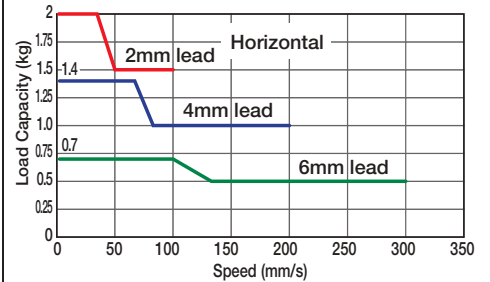

Actuator Specifications

Lead and Load Capacity

(Note 1) Please note that the maximum load capacity decreases as the speed increases.

Model	Feed Screw	Lead (mm)	Max. Load Capacity (Note 1)		Maximum Push Force (N) (Note 2)	Positioning Repeatability (mm)	Stroke (mm)
			Horizontal (kg)	Vertical (kg)			
RCP3-TA3R-I-20P-6-①-②-③-④	Ball Screw	6	~ 0.7	~ 0.3	9	±0.02	20~100 (10mm increments)
RCP3-TA3R-I-20P-4-①-②-③-④		4	~ 1.4	~ 0.6	14		
RCP3-TA3R-I-20P-2-①-②-③-④		2	~ 2	~ 1	28		

Legend ① Stroke ② Compatible controller ③ Cable length ④ Options

(Note 2) See page A-66 for pushing force graphs.

Stroke and Maximum Speed

Lead	Stroke (mm)	
	20 ~ 100 (mm)	200 ~ 300 (mm)
6	300 <200>	
4	200 <133>	
2	100 <67>	

* The values enclosed in "<" ">" apply to vertical usage. (Unit: mm/s)

Cable List

Type	Cable Symbol
Standard (Robot Cables)	P (1m)
	S (3m)
	M (5m)
Special Lengths	X06 (6m) ~ X10 (10m)
	X11 (11m) ~ X15 (15m)
	X16 (16m) ~ X20 (20m)

* The RCP3 comes standard with a robot cable.

* See page A-39 for cables for maintenance.

Option List

Name	Option Code	See Page
Brake	B	→ A-25
Left-Mounted Motor (Standard)	ML	→ A-33
Right-Mounted Motor	MR	→ A-33
Reversed-home	NM	→ A-33

Actuator Specifications

Item	Description
Drive System	Ball screw ø6mm C10 grade
Lost Motion	0.1mm or less
Base	Material: Aluminum (white alumite treated)
Allowable Dynamic Moment (Note 3)	Ma: 3.2 N·m Mb: 4.6 N·m Mc: 5.1 N·m
Ambient Operating Temp./Humidity	0~40°C, 85% RH or less (non-condensing)

(Note 3) Based on a 5,000km service life.

Directions of Allowable Load Moments

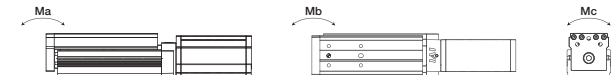

Dimensions

CAD drawings can be downloaded from IAI website. www.robocylinder.de

For Special Orders P. A-9

2/3D CAD

* Below is a drawing of the left-mounted motor model.

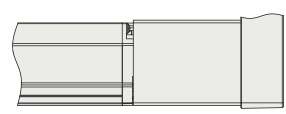

If brake-equipped: (See right for dimensions)

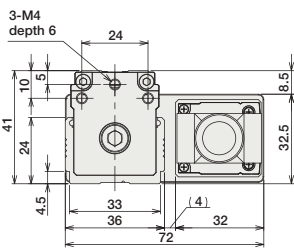
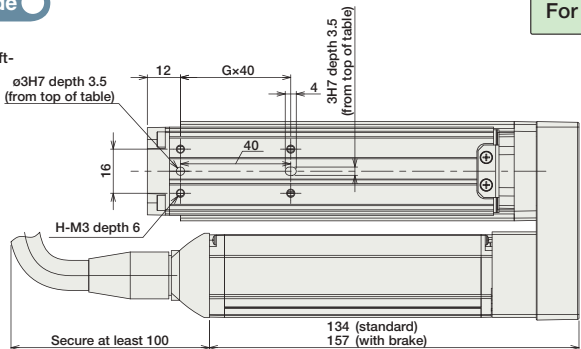

The offset reference position of the moment is the same as TA3C (P270).

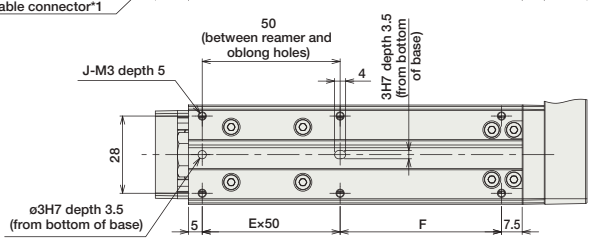
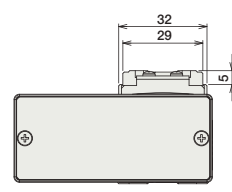
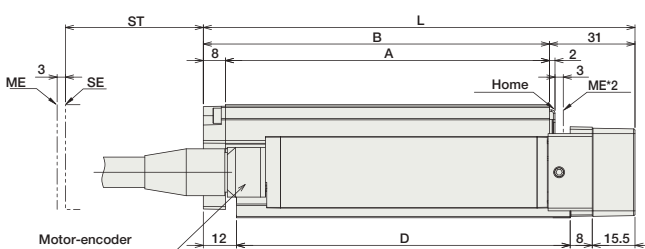

ST : Stroke
ME : Mechanical end
SE : Stroke end

- *1 The motor-encoder cable is connected directly to the motor cover of the actuator. See page A-39 for details on cables.
- *2 When homing, the slider moves to the mechanical end; therefore, please watch for any interference with the surrounding objects.

Dimensions/Weight by Stroke

* Adding a brake will increase the actuator's weight by 0.1kg.

Stroke	20	30	40	50	60	70	80	90	100
L	126.5	136.5	146.5	156.5	166.5	176.5	186.5	196.5	206.5
A	87.5	97.5	107.5	117.5	127.5	137.5	147.5	157.5	167.5
B	95.5	105.5	115.5	125.5	135.5	145.5	155.5	165.5	175.5
D	91	101	111	121	131	141	151	161	171
E	1	1	1	1	2	2	2	2	2
F	28.5	38.5	48.5	58.5	68.5	78.5	88.5	98.5	108.5
G	1	1	1	1	2	2	2	2	2
H	4	4	4	4	6	6	6	6	6
J	6	6	6	6	8	8	8	8	8
Weight (kg)	0.5	0.6	0.6	0.6	0.6	0.7	0.7	0.7	0.7

Compatible Controllers

The RCP3 series actuators can operate with the controllers below. Select the controller according to your usage.

Name	External View	Model	Description	Max. Positioning Points	Input Voltage	Power Supply Capacity	See Page					
Solenoid Valve Type		PMEC-C-20PI-NP-2-2	Easy-to-use controller, even for beginners	3 points	DC24V	2A max.	→ P477					
		PSEP-C-20PI-NP-2-0	Operable with same signal as solenoid valve. Supports both single and double solenoid types. No homing necessary with simple absolute type.					→ P487				
Splash-Proof Solenoid Valve Type		PSEP-CW-20PI-NP-2-0										
Positioner Type		PCON-C-20PI-NP-2-0	Positioning is possible for up to 512 points	512 points								
Safety-Compliant Positioner Type		PCON-CG-20PI-NP-2-0										
Pulse Train Input Type (Differential Line Driver)		PCON-PL-20PI-NP-2-0	Pulse train input type with different line driver support	(-)							→ P525	
Pulse Train Input Type (Open Collector)		PCON-PO-20PI-NP-2-0	Pulse train input type with open collector support									
Serial Communication Type		PCON-SE-20PI-N-0-0	Dedicated to serial communication	64 points								
Field Network Type		RPOON-20P	Dedicated to field network	768 points								
Program Control Type		PSEL-C-1-20PI-NP-2-0	Programmed operation is possible. Operation is possible on up to 2 axes	1500 points							→ P557	

* This is for the single-axis PSEL.

- Slider Type
- Mini
- Standard
- Controllers Integrated
- Rod Type
- Mini
- Standard
- Controllers Integrated
- Table/Arm /Flat Type
- Mini
- Standard
- Gripper/ Rotary Type
- Linear Motor Type
- Cleanroom Type
- Splash Proof
- Controllers
- PMEC /AMEC
- PSEP /ASEP
- ROBO NET
- ERC2
- PCON
- ACON
- SCON
- PSEL
- ASEL
- SSEL
- XSEL
- Pulse Motor
- Servo Motor (24V)
- Servo Motor (230V)
- Linear Motor

- Slider Type
- Mini
- Standard
- Controllers Integrated
- Rod Type
- Mini
- Standard
- Controllers Integrated
- Table/Arm /Flat Type
- Mini
- Standard
- Gripper/ Rotary Type
- Linear Motor Type
- Cleanroom Type
- Splash Proof
- Controllers
- PMEC /AMEC
- PSEP /ASEP
- ROBO NET
- ERC2
- PCON
- ACON
- SCON
- PSEL
- ASEL
- SSEL
- XSEL
- Pulse Motor
- Servo Motor (24V)
- Servo Motor (230V)
- Linear Motor

RCP3-TA4R RoboCylinder Mini Table Type Side-Mounted Motor 40mm Width Pulse Motor Ball Screw

■ Configuration: **RCP3** — **TA4R** — **I** — **28P** — — — — —

Series	Type	Encoder	Motor	Lead	Stroke	Compatible Controllers	Cable Length	Option
		I: Incremental * The simple absolute encoder is also considered type "I".	28P: Pulse motor 28 □ size	6 : 6mm 4 : 4mm 2 : 2mm	20: 20mm 100: 100mm (10mm pitch increments)	P1: PCON RPCON PSEL P3: PMECPSEP	N : None P : 1m S : 3m M : 5m X □ □ : Custom	See Options below * Be sure to specify which side the motor is to be mounted (ML/MR).

* See page Pre-35 for an explanation of the naming convention.

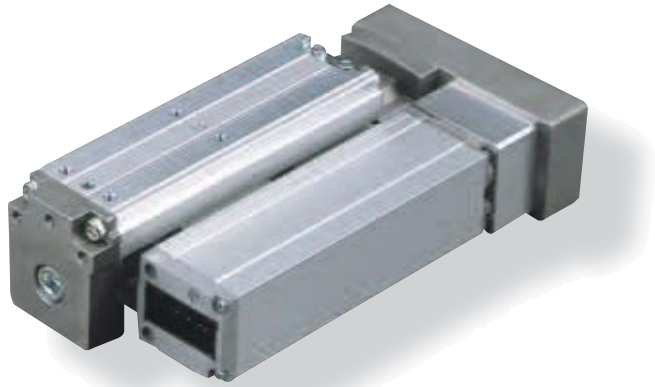

Pictured: TA3R with left-mounted motor (ML).

Technical References P. A-5

POINT
Notes on Selection

(1) The load capacity is based on operation at an acceleration of 0.3G (0.2G for the 2mm-lead model, or when used vertically). 0.3G (0.2G for 2mm lead) is the upper limit of the acceleration.

■ **Speed vs. Load Capacity**
Due to the characteristics of the Pulse motor, the RCP3 series' load capacity decreases at high speeds. In the table below, check if your desired speed and load capacity are supported.

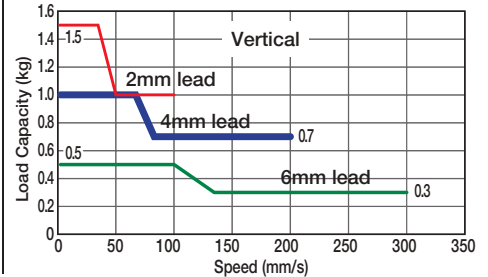
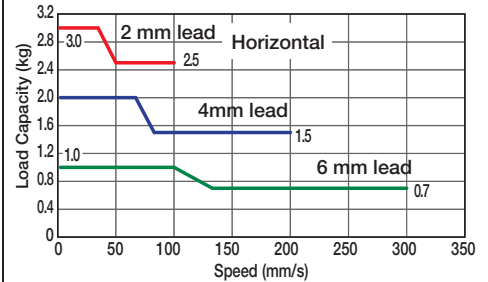

Actuator Specifications							
■ Lead and Load Capacity				■ Stroke and Maximum Speed			
Model	Feed Screw	Lead (mm)	Max. Load Capacity (Note 1)		Maximum Push Force (N) (Note 2)	Positioning Repeatability (mm)	Stroke (mm)
			Horizontal (kg)	Vertical (kg)			
RCP3-TA4R-I-28P-6-①-②-③-④	Ball Screw	6	~ 1	~ 0.5	15	±0.02	20~100 (10mm increments)
RCP3-TA4R-I-28P-4-①-②-③-④		4	~ 2	~ 1	22		
RCP3-TA4R-I-28P-2-①-②-③-④		2	~ 3	~ 1.5	44		

Legend ① Stroke ② Compatible controller ③ Cable length ④ Options (Note 2) See page A-66 for pushing force graphs. (Unit: mm/s)

Type	Cable Symbol
Standard (Robot Cables)	P (1m)
	S (3m)
	M (5m)
Special Lengths	X06 (6m) ~ X10 (10m)
	X11 (11m) ~ X15 (15m)
	X16 (16m) ~ X20 (20m)

* The RCP3 comes standard with a robot cable.
* See page A-39 for cables for maintenance.

Item	Description
Drive System	Ball screw ø6mm C10 grade
Lost Motion	0.1mm or less
Base	Material: Aluminum (white alumite treated)
Allowable Dynamic Moment (Note 3)	Ma: 4.2 N·m Mb: 6 N·m Mc: 8.2 N·m
Ambient Operating Temp./Humidity	0~40°C, 85% RH or less (non-condensing)

(Note 3) Based on a 5,000km service life.

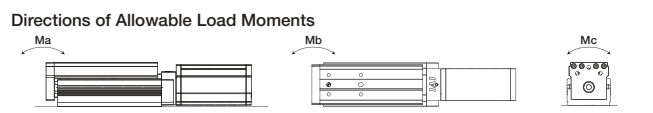

Name	Option Code	See Page
Brake	B	→ A-25
Cable exit direction (Top)	CJT	→ A-25
Cable exit direction (Outside)	CJO	
Cable exit direction (Bottom)	CJB	
Left-Mounted Motor (Standard)	ML	→ A-33
Right-Mounted Motor	MR	→ A-33
Reversed-home	NM	→ A-33

Dimensions

CAD drawings can be downloaded from IAI website. www.robocylinder.de

For Special Orders P. A-9

2/3D CAD

* Below is a drawing of the left-mounted motor model.

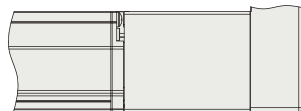

If brake-equipped: (See right for dimensions)

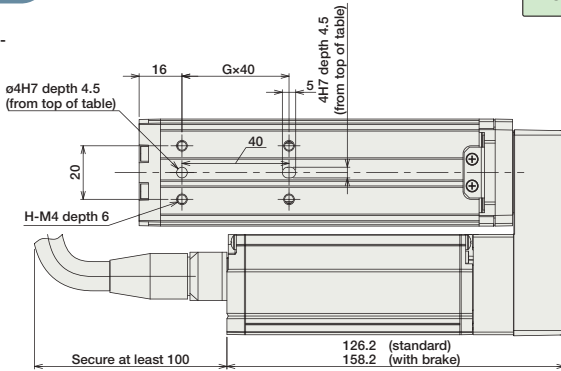

The offset reference position of the moment is the same as TA4C (P272).

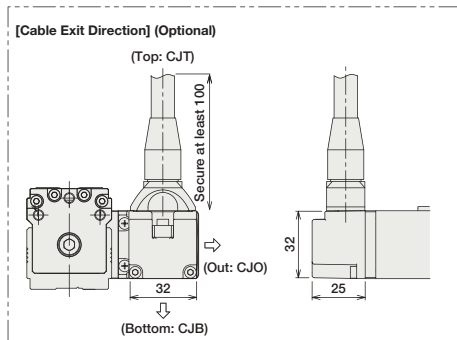
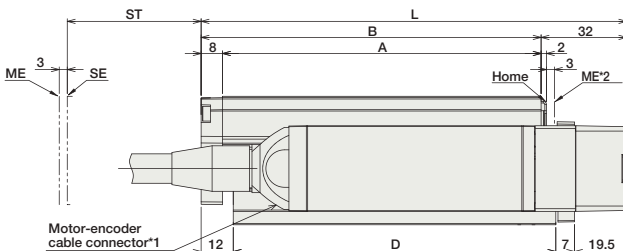
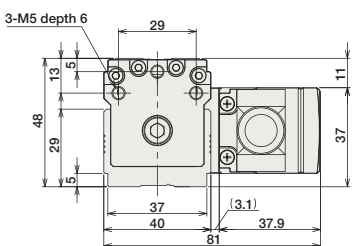
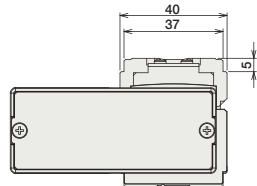

ST : Stroke
ME : Mechanical end
SE : Stroke end

- *1 The motor-encoder cable is connected directly to the motor cover of the actuator. See page A-39 for details on cables.
- *2 When homing, the slider moves to the mechanical end; therefore, please watch for any interference with the surrounding objects.

■ Dimensions/Weight by Stroke

* Adding a brake will increase the actuator's weight by 0.2kg.

Stroke	20	30	40	50	60	70	80	90	100
L	129	139	149	159	169	179	189	199	209
A	89	99	109	119	129	139	149	159	169
B	97	107	117	127	137	147	157	167	177
D	90.5	100.5	110.5	120.5	130.5	140.5	150.5	160.5	170.5
E	1	1	1	1	2	2	2	2	2
F	30.5	40.5	50.5	60.5	20.5	30.5	40.5	50.5	60.5
G	1	1	1	1	2	2	2	2	2
H	4	4	4	4	6	6	6	6	6
J	6	6	6	6	8	8	8	8	8
Weight (kg)	0.7	0.8	0.8	0.8	0.9	0.9	0.9	1.0	1.0

Compatible Controllers

The RCP3 series actuators can operate with the controllers below. Select the controller according to your usage.

Name	External View	Model	Description	Max. Positioning Points	Input Voltage	Power Supply Capacity	See Page
Solenoid Valve Type		PMEC-C-28PI-NP-2-2	Easy-to-use controller, even for beginners	3 points	AC115V AC230V	See P481	→ P477
		PSEP-C-28PI-NP-2-0	Operable with same signal as solenoid valve. Supports both single and double solenoid types. No homing necessary with simple absolute type.				
Splash-Proof Solenoid Valve Type		PSEP-CW-28PI-NP-2-0					
Positioner Type		PCON-C-28PI-NP-2-0	Positioning is possible for up to 512 points	512 points			
Safety-Compliant Positioner Type		PCON-CG-28PI-NP-2-0					
Pulse Train Input Type (Differential Line Driver)		PCON-PL-28PI-NP-2-0	Pulse train input type with different line driver support	(-)	DC24V	2A max.	→ P525
Pulse Train Input Type (Open Collector)		PCON-PO-28PI-NP-2-0	Pulse train input type with open collector support				
Serial Communication Type		PCON-SE-28PI-N-0-0	Dedicated to serial communication	64 points			
Field Network Type		RPCON-28P	Dedicated to field network	768 points			→ P503
Program Control Type		PSEL-C-1-28PI-NP-2-0	Programmed operation is possible. Operation is possible on up to 2 axes	1500 points			→ P557

* This is for the single-axis PSEL.

- Slider Type
- Mini
- Standard
- Controllers Integrated
- Rod Type
- Mini
- Standard
- Controllers Integrated
- Table/Arm /Flat Type
- Mini
- Standard
- Gripper/ Rotary Type
- Linear Motor Type
- Cleanroom Type
- Splash Proof
- Controllers
- PMEC /AMEC
- PSEP /ASEP
- ROBO NET
- ERC2
- PCON
- ACON
- SCON
- PSEL
- ASEL
- SSEL
- XSEL
- Pulse Motor
- Servo Motor (24V)
- Servo Motor (230V)
- Linear Motor

RCP3-TA5R RoboCylinder Table Type Side-Mounted Motor 55mm Width Pulse Motor Ball Screw

■ Configuration: **RCP3** - **TA5R** - **I** - **35P** - [] - [] - [] - [] - []

Series - Type - Encoder - Motor - Lead - Stroke - Compatible Controllers - Cable Length - Option

I: Incremental
* The simple absolute encoder is also considered type "I".

35P: Pulse motor
35 □ size

10: 10mm
5: 5mm
2.5: 2.5mm

25: 25mm
100: 100mm (25mm pitch increments)

P1: PCON
RPCON
PSEL
P3: PMEC
PSEP

N : None
P : 1m
S : 3m
M : 5m
X □ □ : Custom

See Options below
* Be sure to specify which side the motor is to be mounted (ML/MR).

* See page Pre-35 for an explanation of the naming convention.



Technical References P. A-5

- POINT**
Notes on Selection
- Since the RCP3 series use a pulse motor, the load capacity decreases at high speeds. Check in the Speed vs. Load Capacity graph to see if your desired speed and load capacity are supported.
 - Please note that the maximum speed is different when used horizontally versus vertically.
 - The load capacity is based on operation at an acceleration of 0.3G (0.2G for the 2.5mm-lead model, or when used vertically). This is the upper limit of the acceleration.

■ Speed vs. Load Capacity
Due to the characteristics of the Pulse motor, the RCP3 series' load capacity decreases at high speeds. In the table below, check if your desired speed and load capacity are supported.

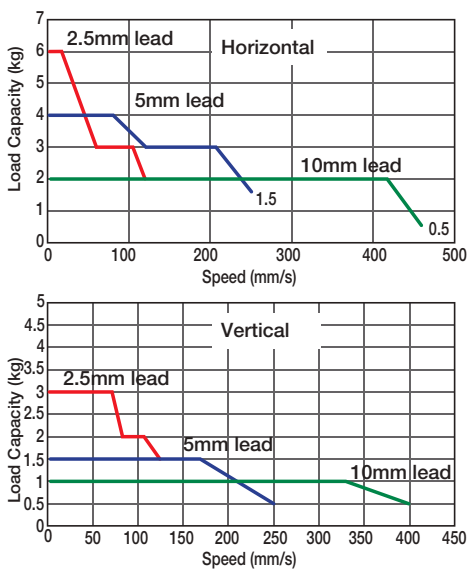

Actuator Specifications						Stroke and Maximum Speed	
■ Lead and Load Capacity						Stroke	
Model	Lead (mm)	Max. Load Capacity		Maximum Push Force (N)	Stroke (mm)	Lead	25 ~ 100 (25mm increments)
		Horizontal (kg)	Vertical (kg)				
RCP3-TA5R-I-35P-10-①-②-③-④	10	~ 2	~ 1	34	25~100 (25mm increments)	10	465 <400>
RCP3-TA5R-I-35P-5-①-②-③-④	5	~ 4	~ 1.5	68		5	250
RCP3-TA5R-I-35P-2.5-①-②-③-④	2.5	~ 6	~ 3	136		2.5	125

Legend ① Stroke ② Compatible controller ③ Cable length ④ Options

* The values enclosed in "< >" apply to vertical usage. (Unit: mm/s)

Cable List

Type	Cable Symbol
Standard (Robot Cables)	P (1m)
	S (3m)
	M (5m)
Special Lengths	X06 (6m) ~ X10 (10m)
	X11 (11m) ~ X15 (15m)
	X16 (16m) ~ X20 (20m)

* The standard cable is the motor-encoder integrated robot cable.
* See page A-39 for cables for maintenance.

Actuator Specifications

Item	Description
Drive System	Ball screw ø8mm C10 grade
Positioning Repeatability	±0.02mm
Lost Motion	0.1mm or less
Base	Material: Material: Aluminum (special alumite treated)
Allowable Static Load Moment	Ma: 25.5 N·m Mb: 36.5 N·m Mc: 56.1 N·m
Allowable Dynamic Load Moment	Ma: 6.57 N·m Mb: 9.32 N·m Mc: 14.32 N·m
Overhang Load Length	Within the load moment range
Ambient Operating Temp./Humidity	0~40°C, 85% RH or less (non-condensing)

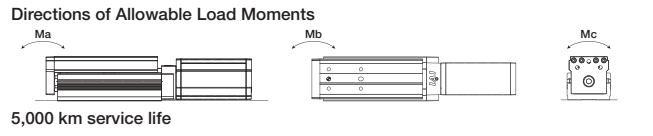

Option List

Name	Option Code	See Page
Brake	B	→ A-25
Cable exit direction (Top)	CJT	→ A-25
Cable exit direction (Outside)	CJO	
Cable exit direction (Bottom)	CJB	
Left-Mounted Motor (Standard)	ML	→ A-33
Right-Mounted Motor	MR	→ A-33
Reversed-home	NM	→ A-33

Dimensions

CAD drawings can be downloaded from IAI website. www.robocylinder.de

For Special Orders P. A-9

2/3D CAD

* Please note that, for 25mm-stroke model with brake, the motor unit protrudes from the end of the table.

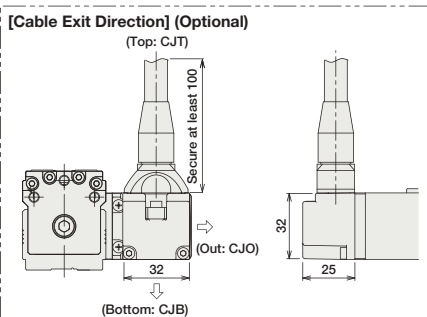
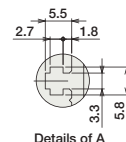
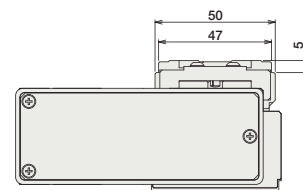
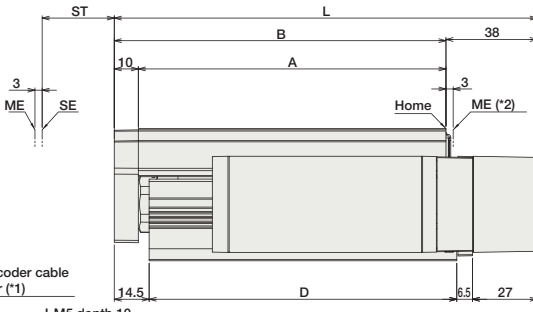
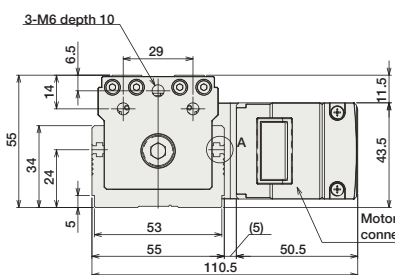
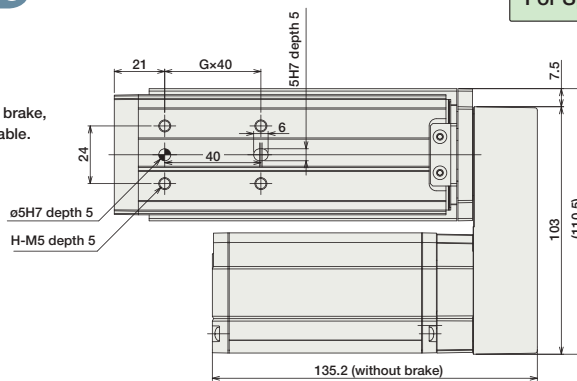
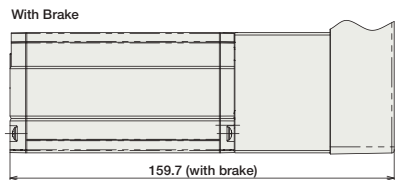

Dimensions/Weight by Stroke

* Adding a brake will increase the weight by 0.3kg.

Stroke	25	50	75	100
L	151	176	201	226
A	103	128	153	178
B	113	138	163	188
D	103	128	153	178
E	1	1	2	2
F	43	68	43	68
G	1	1	2	2
H	4	4	6	6
J	6	6	8	8
Weight (kg)	1.4	1.6	1.7	1.9

(*1) The motor-encoder cable is provided as an integrated cable. (see page A-39)
 (*2) After homing, the slider moves to the ME; therefore, please watch for any interference with the surrounding objects.
 ME: Mechanical end
 SE: Stroke end

Compatible Controllers

The RCP3 series actuators can operate with the controllers below. Select the controller according to your usage.

Name	External View	Model	Description	Max. Positioning Points	Input Voltage	Power Supply Capacity	See Page
Solenoid Valve Type		PMEC-C-35PI-NP-2-2	Easy-to-use controller, even for beginners	3 points	AC115V AC230V	See P481	→ P477
Splash-Proof Solenoid Valve Type		PSEP-C-35PI-NP-2-0 PSEP-CW-35PI-NP-2-0	Operable with same signal as solenoid valve. Supports both single and double solenoid types. No homing necessary with simple absolute type.				
Positioner Type		PCON-C-35PI-NP-2-0	Positioning is possible for up to 512 points	512 points	DC24V	2A max.	→ P525
Safety-Compliant Positioner Type		PCON-CG-35PI-NP-2-0					
Pulse Train Input Type (Differential Line Driver)		PCON-PL-35PI-NP-2-0	Pulse train input type with differential line driver support	(-)	DC24V	2A max.	→ P525
Pulse Train Input Type (Open Collector)		PCON-PO-35PI-NP-2-0	Pulse train input type with open collector support				
Serial Communication Type		PCON-SE-35PI-NI-0-0	Dedicated to serial communication	64 points	DC24V	2A max.	→ P503
Field Network Type		RPCON-35P	Dedicated to field network	768 points			
Program Control Type		PSEL-C-1-35PI-NP-2-0	Programmed operation is possible. Operation is possible on up to 2 axes	1500 points	DC24V	2A max.	→ P557

* This is for the single-axis PSEL.

- Slider Type
- Mini
- Standard
- Controllers Integrated
- Rod Type
- Mini
- Standard
- Controllers Integrated
- Table/Arm /Flat Type
- Mini
- Standard
- Gripper/ Rotary Type
- Linear Motor Type
- Cleanroom Type
- Splash Proof
- Controllers
- PMEC /AMEC
- PSEP /ASEP
- ROBO NET
- ERC2
- PCON
- ACON
- SCON
- PSEL
- ASEL
- SSEL
- XSEL
- Pulse Motor
- Servo Motor (24V)
- Servo Motor (230V)
- Linear Motor

RCP3-TA6R

RoboCylinder Table Type Side-Mounted Motor 65mm Width Pulse Motor Ball Screw

■ Configuration: **RCP3-TA6R-I-42P** - [] - [] - [] - []

Series — Type — Encoder — Motor — Lead — Stroke — Compatible Controllers — Cable Length — Option

I: Incremental
* The simple absolute encoder is also considered type "I".

42P: Pulse motor
42 □ size

12: 12mm
6: 6mm
3: 3mm

25: 25mm
150: 150mm (25mm pitch increments)

P1: PCON
RPCON
PSEL

P3: PMEC
PSEP

N : None
P : 1m
S : 3m
M : 5m
X □ : Custom

See Options below
* Be sure to specify which side the motor is to be mounted (ML/MR).

* See page Pre-35 for an explanation of the naming convention.



Technical References P. A-5



- (1) Since the RCP3 series use a pulse motor, the load capacity decreases at high speeds. Check in the Speed vs. Load Capacity graph to see if your desired speed and load capacity are supported.
- (2) Please note that the maximum speed is different when used horizontally versus vertically.
- (3) The load capacity is based on operation at an acceleration of 0.3G (0.2G for the 3mm-lead model, or when used vertically). This is the upper limit of the acceleration.

■ Speed vs. Load Capacity
Due to the characteristics of the Pulse motor, the RCP3 series' load capacity decreases at high speeds. In the table below, check if your desired speed and load capacity are supported.

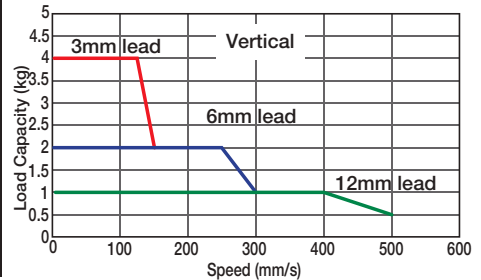
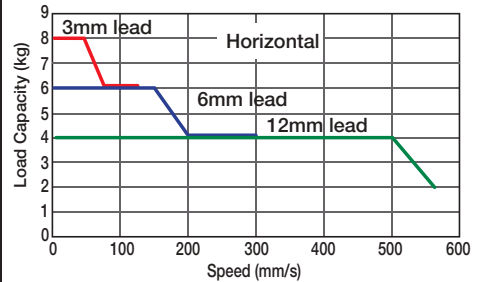

Actuator Specifications

Lead and Load Capacity

Model	Lead (mm)	Max. Load Capacity		Maximum Push Force (N)	Stroke (mm)
		Horizontal (kg)	Vertical (kg)		
RCP3-TA6R-I-42P-12-①-②-③-④	12	~ 4	~ 1	47	25~150 (25mm increments)
RCP3-TA6R-I-42P-6-①-②-③-④	6	~ 6	~ 2	95	
RCP3-TA6R-I-42P-3-①-②-③-④	3	~ 8	~ 4	189	

Legend ① Stroke ② Compatible controller ③ Cable length ④ Options

Stroke and Maximum Speed

Stroke / Lead	25 ~ 150 (25mm increments)
12	560 <500>
6	300
3	150

* The values enclosed in "<" ">" apply to vertical usage. (Unit: mm/s)

Cable List

Type	Cable Symbol
Standard (Robot Cables)	P (1m)
	S (3m)
	M (5m)
Special Lengths	X06 (6m) ~ X10 (10m)
	X11 (11m) ~ X15 (15m)
	X16 (16m) ~ X20 (20m)

* The standard cable is the motor-encoder integrated robot cable.
* See page A-39 for cables for maintenance.

Option List

Name	Option Code	See Page
Brake	B	→ A-25
Cable exit direction (Top)	CJT	→ A-25
Cable exit direction (Outside)	CJO	
Cable exit direction (Bottom)	CJB	
Left-Mounted Motor (Standard)	ML	→ A-33
Right-Mounted Motor	MR	→ A-33
Reversed-home	NM	→ A-33

Actuator Specifications

Item	Description
Drive System	Ball screw ø10mm C10 grade
Positioning Repeatability	±0.02mm
Lost Motion	0.1mm or less
Base	Material: Material: Aluminum (special alumite treated)
Allowable Static Load Moment	Ma: 29.4 N·m Mb: 42.0 N·m Mc: 74.1 N·m
Allowable Dynamic Load Moment	Ma: 7.26 N·m Mb: 10.3 N·m Mc: 18.25 N·m
Overhang Load Length	Within the load moment range
Ambient Operating Temp./Humidity	0~40°C, 85% RH or less (non-condensing)

Directions of Allowable Load Moments

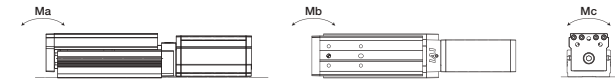

5,000 km service life

- Slider Type
- Mini
- Standard
- Controllers Integrated
- Rod Type
- Mini
- Standard
- Controllers Integrated
- Table/Arm /Flat Type
- Mini
- Standard
- Gripper/ Rotary Type
- Linear Motor Type
- Cleanroom Type
- Splash Proof
- Controllers
- PMEC /AMEC
- PSEP /ASEP
- ROBO NET
- ERC2
- PCON
- ACON
- SCON
- PSEL
- ASEL
- SSEL
- XSEL
- Pulse Motor
- Servo Motor (24V)
- Servo Motor (230V)
- Linear Motor

Dimensions

CAD drawings can be downloaded from IAI website. www.robocylinder.de

For Special Orders P. A-9

2/3D CAD

* Please note that, for 25mm stroke model with brake, the motor unit protrudes from the end of the table.

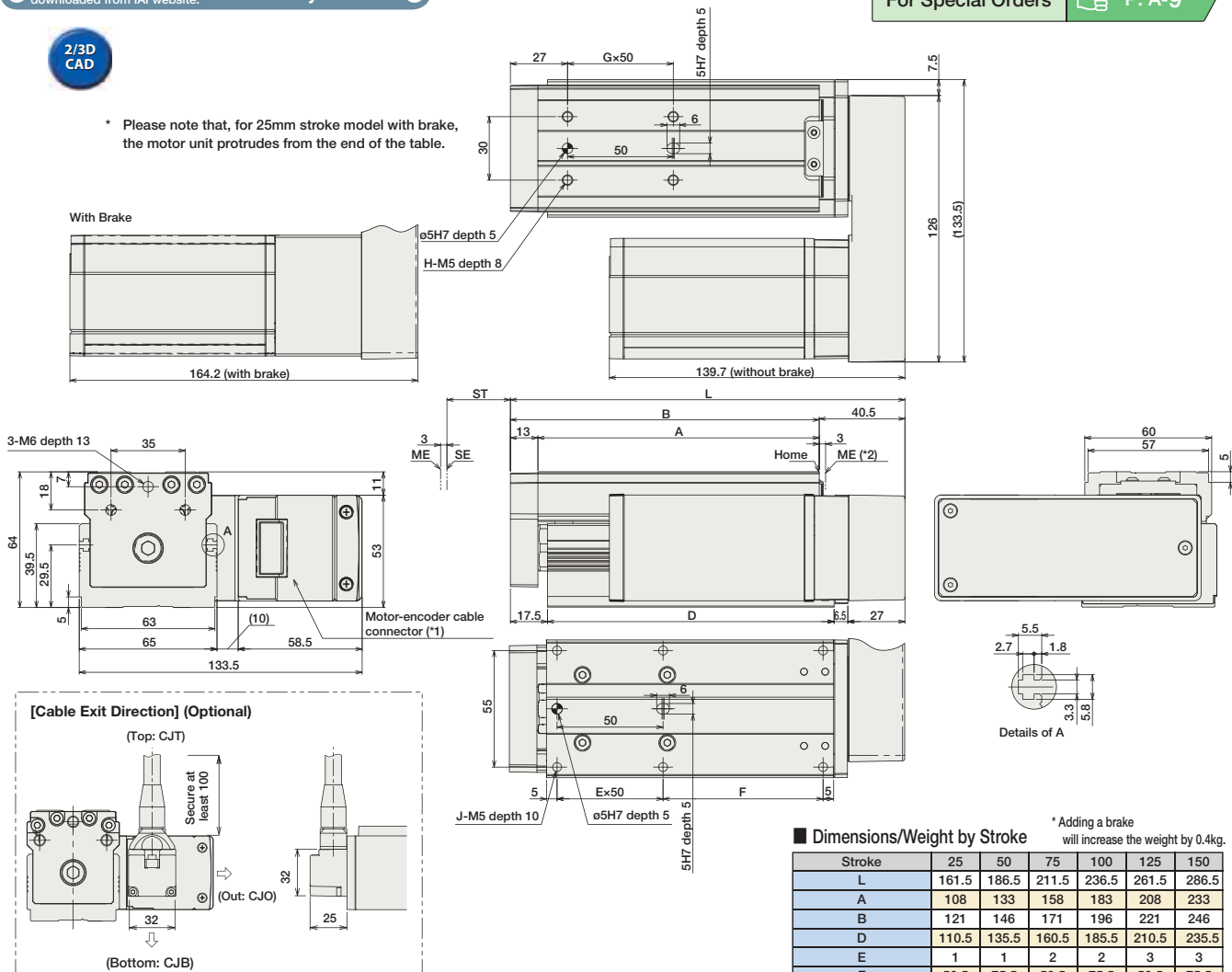

■ Dimensions/Weight by Stroke * Adding a brake will increase the weight by 0.4kg.

Stroke	25	50	75	100	125	150
L	161.5	186.5	211.5	236.5	261.5	286.5
A	108	133	158	183	208	233
B	121	146	171	196	221	246
D	110.5	135.5	160.5	185.5	210.5	235.5
E	1	1	2	2	3	3
F	50.5	75.5	50.5	75.5	50.5	75.5
G	1	1	2	2	3	3
H	4	4	6	6	8	8
J	6	6	8	8	10	10
Weight (kg)	2.1	2.3	2.5	2.7	2.9	3.1

(*1) The motor-encoder cable is provided as an integrated cable. (see page A-39)
 (*2) After homing, the slider moves to the ME; therefore, please watch for any interference with the surrounding objects.
 ME: Mechanical end SE: Stroke end

Compatible Controllers

The RCP3 series actuators can operate with the controllers below. Select the controller according to your usage.

Name	External View	Model	Description	Max. Positioning Points	Input Voltage	Power Supply Capacity	See Page
Solenoid Valve Type		PMEC-C-42PI-NP-2-2	Easy-to-use controller, even for beginners	3 points	AC115V AC230V	See P481	→ P477
		PSEP-C-42PI-NP-2-0	Operable with same signal as solenoid valve. Supports both single and double solenoid types. No homing necessary with simple absolute type.				
Splash-Proof Solenoid Valve Type		PSEP-CW-42PI-NP-2-0					
Positioner Type		PCON-C-42PI-NP-2-0	Positioning is possible for up to 512 points	512 points	DC24V	2A max.	
Safety-Compliant Positioner Type		PCON-CG-42PI-NP-2-0					
Pulse Train Input Type (Differential Line Driver)		PCON-PL-42PI-NP-2-0	Pulse train input type with different line driver support	(-)			→ P525
Pulse Train Input Type (Open Collector)		PCON-PO-42PI-NP-2-0	Pulse train input type with open collector support				
Serial Communication Type		PCON-SE-42PI-N-0-0	Dedicated to serial communication	64 points			
Field Network Type		RPCON-42P	Dedicated to field network	768 points			→ P503
Program Control Type		PSEL-C-1-42PI-NP-2-0	Programmed operation is possible. Operation is possible on up to 2 axes	1500 points			→ P557

* This is for the single-axis PSEL.

- Slider Type
- Mini
- Standard
- Controllers Integrated
- Rod Type
- Mini
- Standard
- Controllers Integrated
- Table/Arm /Flat Type
- Mini
- Standard
- Gripper/ Rotary Type
- Linear Motor Type
- Cleanroom Type
- Splash Proof
- Controllers
- PMEC /AMEC
- PSEP /ASEP
- ROBO NET
- ERC2
- PCON
- ACON
- SCON
- PSEL
- ASEL
- SSEL
- XSEL
- Pulse Motor
- Servo Motor (24V)
- Servo Motor (230V)
- Linear Motor

RCP3-TA7R RoboCylinder Table Type Side-Mounted Motor 75mm Width Pulse Motor Ball Screw

■ Configuration: **RCP3-TA7R-I-42P** - [] - [] - [] - []

Series — Type — Encoder — Motor — Lead — Stroke — Compatible Controllers — Cable Length — Option

I: Incremental
* The simple absolute encoder is also considered type "I".

42P: Pulse motor
42 □ size

12 : 12mm
6 : 6mm
3 : 3mm

25: 25mm
200: 200mm (25mm pitch increments)

P1: PCON
RPCON
PSEL

P3: PMEAC
PSEP

N : None
P : 1m
S : 3m
M : 5m
X □ □ : Custom

See Options below
* Be sure to specify which side the motor is to be mounted (ML/MR).

* See page Pre-35 for an explanation of the naming convention.

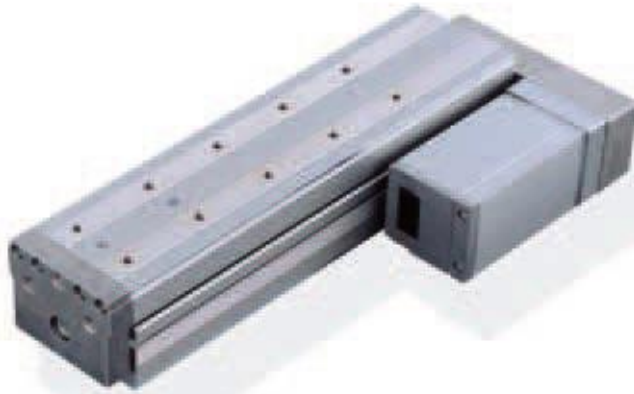

Technical References P. A-5



- (1) Since the RCP3 series use a pulse motor, the load capacity decreases at high speeds. Check in the Speed vs. Load Capacity graph below to see if your desired speed and load capacity are supported.
- (2) Please note that the maximum speed is different when used horizontally versus vertically.
- (3) The load capacity is based on operation at an acceleration of 0.3G (0.2G for the 3mm-lead model, or when used vertically). This is the upper limit of the acceleration.

■ Speed vs. Load Capacity
Due to the characteristics of the Pulse motor, the RCP3 series' load capacity decreases at high speeds. In the table below, check if your desired speed and load capacity are supported.

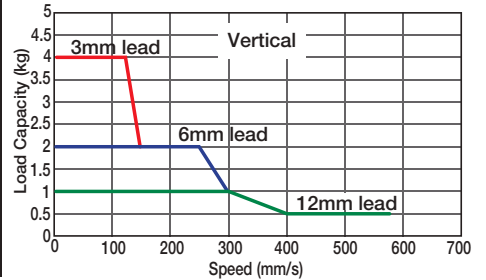
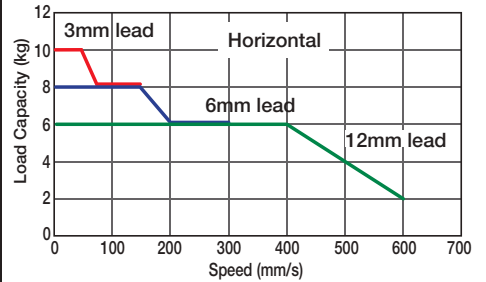

Actuator Specifications

Lead and Load Capacity

Model	Lead (mm)	Max. Load Capacity		Maximum Push Force (N)	Stroke (mm)
		Horizontal (kg)	Vertical (kg)		
RCP3-TA7R-I-42P-12-①-②-③-④	12	~ 6	~ 1	47	25~200 (25mm increments)
RCP3-TA7R-I-42P-6-①-②-③-④	6	~ 8	~ 2	95	
RCP3-TA7R-I-42P-3-①-②-③-④	3	~ 10	~ 4	189	

Legend ① Stroke ② Compatible controller ③ Cable length ④ Options

Stroke and Maximum Speed

Lead	Stroke	25 ~ 200 (25mm increments)
		12
6	300	
3	150	

* The values enclosed in "< >" apply to vertical usage. (Unit: mm/s)

Cable List

Type	Cable Symbol
Standard (Robot Cables)	P (1m)
	S (3m)
	M (5m)
Special Lengths	X06 (6m) ~ X10 (10m)
	X11 (11m) ~ X15 (15m)
	X16 (16m) ~ X20 (20m)

* The standard cable is the motor-encoder integrated robot cable.
* See page A-39 for cables for maintenance.

Option List

Name	Option Code	See Page
Brake	B	→ A-25
Cable exit direction (Top)	CJT	→ A-25
Cable exit direction (Outside)	CJO	
Cable exit direction (Bottom)	CJB	
Left-Mounted Motor (Standard)	ML	→ A-33
Right-Mounted Motor	MR	→ A-33
Reversed-home	NM	→ A-33

Actuator Specifications

Item	Description
Drive System	Ball screw ø10mm C10 grade
Positioning Repeatability	±0.02mm
Lost Motion	0.1mm or less
Base	Material: Material: Aluminum (special alumite treated)
Allowable Static Load Moment	Ma: 42.6 N·m Mb: 60.8 N·m Mc: 123.2 N·m
Allowable Dynamic Load Moment	Ma: 9.91 N·m Mb: 14.13 N·m Mc: 28.65 N·m
Overhang Load Length	Within the load moment range
Ambient Operating Temp./Humidity	0~40°C, 85% RH or less (non-condensing)

Directions of Allowable Load Moments

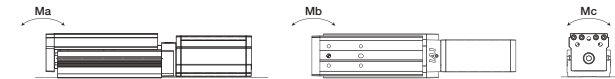

5,000 km service life

Dimensions

CAD drawings can be downloaded from IAI website. www.robocylinder.de

For Special Orders P. A-9



* Please note that, for 25mm stroke model with brake, the motor unit protrudes from the end of the table.

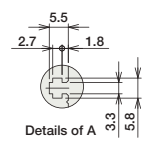
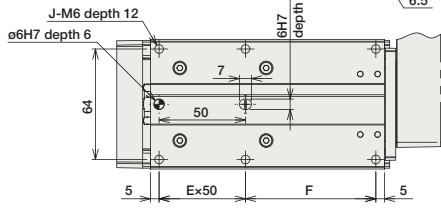
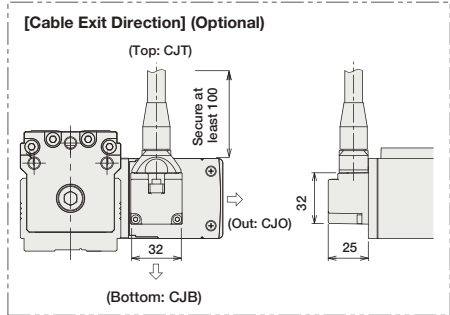
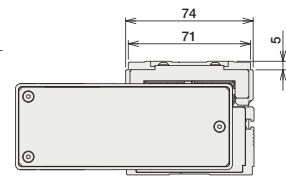
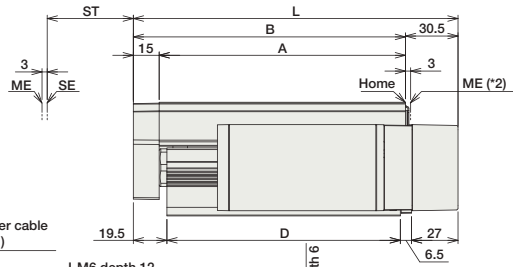
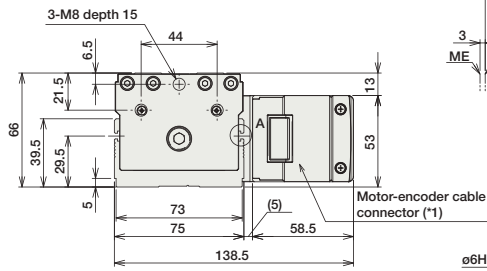
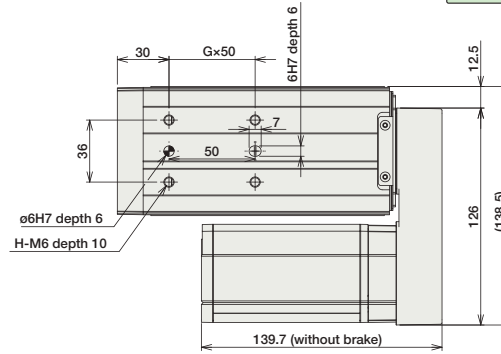
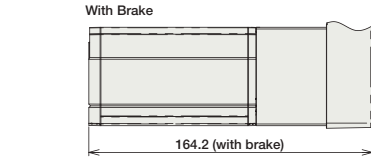

■ Dimensions/Weight by Stroke * Adding a brake will increase the weight by 0.4kg.

Stroke	25	50	75	100	125	150	175	200
L	163.5	188.5	213.5	238.5	263.5	288.5	313.5	338.5
A	118	143	168	193	218	243	268	293
B	133	158	183	208	233	258	283	308
D	110.5	135.5	160.5	185.5	210.5	235.5	260.5	285.5
E	1	1	2	2	3	3	4	4
F	50.5	75.5	50.5	75.5	50.5	75.5	50.5	75.5
G	1	1	2	2	3	3	4	4
H	4	4	6	6	8	8	10	10
J	6	6	8	8	10	10	12	12
Weight (kg)	2.4	2.6	2.8	3.1	3.3	3.5	3.7	3.9

(*1) The motor-encoder cable is provided as an integrated cable. (see page A-39)
 (*2) After homing, the slider moves to the ME; therefore, please watch for any interference with the surrounding objects.
 ME: Mechanical end
 SE: Stroke end

Compatible Controllers

The RCP3 series actuators can operate with the controllers below. Select the controller according to your usage.

Name	External View	Model	Description	Max. Positioning Points	Input Voltage	Power Supply Capacity	See Page
Solenoid Valve Type		PMEC-C-42PI-NP-2-2	Easy-to-use controller, even for beginners	3 points	AC115V AC230V	See P481	→ P477
		PSEP-C-42PI-NP-2-0	Operable with same signal as solenoid valve. Supports both single and double solenoid types. No homing necessary with simple absolute type.				
Splash-Proof Solenoid Valve Type		PSEP-CW-42PI-NP-2-0					
Positioner Type		PCON-C-42PI-NP-2-0	Positioning is possible for up to 512 points	512 points			
Safety-Compliant Positioner Type		PCON-CG-42PI-NP-2-0					
Pulse Train Input Type (Differential Line Driver)		PCON-PL-42PI-NP-2-0	Pulse train input type with differential line driver support	(-)	DC24V	2A max.	→ P525
Pulse Train Input Type (Open Collector)		PCON-PO-42PI-NP-2-0	Pulse train input type with open collector support				
Serial Communication Type		PCON-SE-42PI-N-0-0	Dedicated to serial communication	64 points			
Field Network Type		RPCON-42P	Dedicated to field network	768 points			→ P503
Program Control Type		PSEL-C-1-42PI-NP-2-0	Programmed operation is possible. Operation is possible on up to 2 axes	1500 points			→ P557

* This is for the single-axis PSEL.

- Slider Type
- Mini
- Standard
- Controllers Integrated
- Rod Type
- Mini
- Standard
- Controllers Integrated
- Table/Arm /Flat Type
- Mini
- Standard
- Gripper/ Rotary Type
- Linear Motor Type
- Cleanroom Type
- Splash Proof
- Controllers
- PMEC /AMEC
- PSEP /ASEP
- ROBO NET
- ERC2
- PCON
- ACON
- SCON
- PSEL
- ASEL
- SSEL
- XSEL
- Pulse Motor
- Servo Motor (24V)
- Servo Motor (230V)
- Linear Motor

RCP2-GRSS

RoboCylinder 2-Finger Gripper Mini Slider Type 42mm Width Pulse Motor

■ Configuration: **RCP2-GRSS-I-20P-30-8**

Series — Type — Encoder — Motor — Deceleration Ratio — Stroke — Compatible Controllers — Cable Length — Option

I: Incremental
* The Simple absolute encoder is also considered type "I".

20P: 20 □ size Pulse motor
30: 1/30 deceleration ratio

8: 8mm (4mm per side)

P1: PCON
RPCON
PSEL
P3: PMEC
PSEP

N: None
P: 1m
S: 3m
M: 5m
X □ □ : Custom

NM: Reversed-home
FB: Flange bracket
SB: Shaft bracket

* See page Pre-35 for an explanation of the naming convention.



Technical References P. A-5

■ Gripping Force Adjustment
The gripping (pushing) force can be adjusted freely within the range of current limits of 20% to 70%.

* The gripping forces in the following diagrams indicate the sums of gripping forces of both fingers.

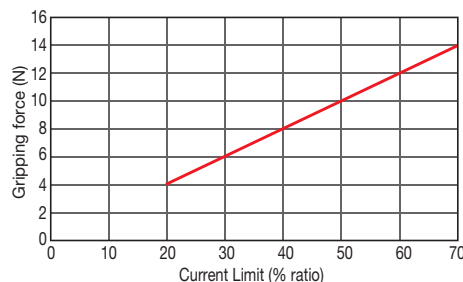

* The value of the gripping (pushing) in the graph is only reference. Please note that there is a maximum variation of about 15%.

* Please note that, when gripping (pushing), the speed is fixed at 5mm/s.

- POINT**
Notes on Selection
- (1) The maximum opening/closing speed indicates the operating speed on one side. The relative operating speed is twice this value.
 - (2) The maximum gripping force is the sum of the gripping forces of both fingers, at a gripping point where there is no offset or overhang distance. The work piece weight that can be actually moved depends on the friction coefficient between the gripper fingers and the work piece, as well as on the shape of the work piece. As a rough guide, a work piece's weight should not exceed 1/10 to 1/20 of the gripping force. (See page A-74 for details.)
 - (3) The rated acceleration while moving is 0.3G.

Actuator Specifications

Lead and Load Capacity

Model	Deceleration Ratio	Max. Gripping Force (N)	Stroke (mm)
RCP2-GRSS-I-20P-30-8-①-②-③	30	14	8 (4 per side)

Legend: ① Compatible controllers ② Cable length ③ Options

Stroke and Maxi. Opening/Closing Speed

Deceleration Ratio	Stroke	8 (mm)
	30	78 (per side)

(Unit: mm/s)

Cable List

Type	Cable Symbol
Standard Type (Robot Cables)	P (1m)
	S (3m)
	M (5m)
Special Lengths	X06 (6m) ~ X10 (10m)
	X11 (11m) ~ X15 (15m)
	X16 (16m) ~ X20 (20m)

* The standard cable is the motor-encoder integrated robot cable.

* See page A-39 for cables for maintenance.

Actuator Specifications

Item	Description
Drive System	Worm gear + helical gear + helical rack
Positioning Repeatability	±0.01mm
Backlash	0.2mm or less per side (constantly pressed out by a spring)
Lost Motion	0.05mm or less per side
Guide	Linear guide
Allowable Static Load Moment	Ma: 0.5 N·m Mb: 0.5 N·m Mc: 1.5 N·m
Weight	0.2kg
Ambient Operating Temp./Humidity	0~40°C, 85% RH or less (non-condensing)

Option List

Name	Option Code	See Page
Reversed-home	NM	→ A-33
Flange bracket	FB	→ A-26
Shaft bracket	SB	→ A-36

Dimensions

CAD drawings can be downloaded from IAI website. www.robocylinder.de



- * The opening side of the slider is the home position.
- *1 The motor-encoder cable is connected here. See page A-39 for details on cables.

For Special Orders P. A-9

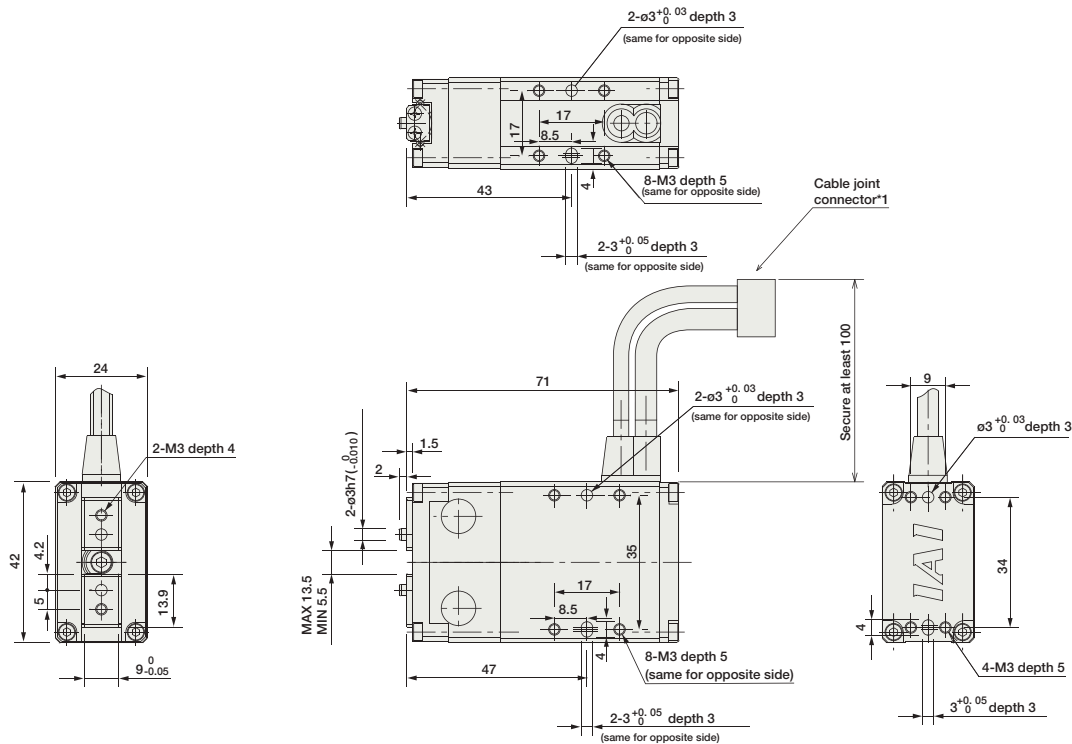

Weight (kg) 0.2

Compatible Controllers

The RCP2 series actuators can operate with the controllers below. Select the controller according to your usage.

Name	External View	Model	Description	Max. Positioning Points	Input Voltage	Power Supply Capacity	See Page
Solenoid Valve Type		PMEC-C-20PI-NP-2-2	Easy-to-use controller, even for beginners	3 points	AC115V AC230V	P481 See	→ P477
Splash-Proof Solenoid Valve Type		PSEP-C-20PI-NP-2-0 PSEP-CW-20PI-NP-2-0	Operable with same signal as solenoid valve. Supports both single and double solenoid types. No homing necessary with simple absolute type.				
Positioner Type		PCON-C-20PI-NP-2-0	Positioning is possible for up to 512 points	512 points	DC24V	2A max.	
Safety-Compliant Positioner Type		PCON-CG-20PI-NP-2-0					
Pulse Train Input Type (Differential Line Driver)		PCON-PL-20PI-NP-2-0	Pulse train input type with differential line driver support	(-)	DC24V	2A max.	→ P525
Pulse Train Input Type (Open Collector)		PCON-PO-20PI-NP-2-0	Pulse train input type with open collector support				
Serial Communication Type		PCON-SE-20PI-N-0-0	Dedicated to communication	64 points	DC24V	2A max.	
Field Network Type		RPCON-20P	Dedicated to field network	768 points	DC24V	2A max.	→ P503
Program Control Type		PSEL-C-1-20PI-NP-2-0	Programmed operation is possible. Operation is possible on up to 2 axes	1500 points	DC24V	2A max.	→ P557

* This is for the single-axis PSEL.

- Slider Type
- Mini
- Standard
- Controllers Integrated
- Rod Type
- Mini
- Standard
- Controllers Integrated
- Table/Arm /Flat Type
- Mini
- Standard
- Gripper/ Rotary Type
- Linear Motor Type
- Cleanroom Type
- Splash-Proof
- Controllers
- PMEC /AMEC
- PSEP /ASEP
- ROBO NET
- ERC2
- PCON
- ACON
- SCON
- PSEL
- ASEL
- SSEL
- XSEL
- Pulse Motor
- Servo Motor (24V)
- Servo Motor (230V)
- Linear Motor

RCP2-GRLS

RoboCylinder 2-Finger Gripper Mini Lever Type 42mm Width Pulse Motor

■ Configuration: **RCP2** - **GRLS** - **I** - **20P** - **30** - **180** - - -

Series — Type — Encoder — Motor — Deceleration Ratio — Stroke — Compatible Controllers — Cable Length — Option

I: Incremental
* The Simple absolute encoder is also considered type "I".

20P: 20 □ size Pulse motor

30: 1/30 deceleration ratio

180: 180 degrees (90 degrees per side)

P1: PCON
RPCON
PSEL
P3: PMEC
PSEP

N: None
P: 1m
S: 3m
M: 5m
X□□: Custom

NM: Reversed-home
FB: Flange bracket
SB: Shaft bracket

* See page Pre-35 for an explanation of the naming convention.

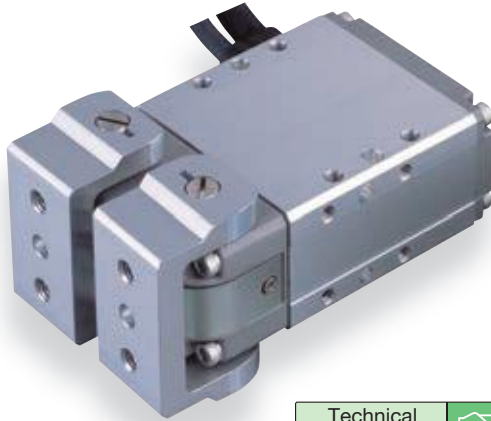

Technical References P. A-5

■ Gripping Force Adjustment
The gripping (pushing) force can be adjusted freely within the range of current limits of 20% to 70%.

* The gripping forces in the following diagrams indicate the sums of gripping forces of both fingers.

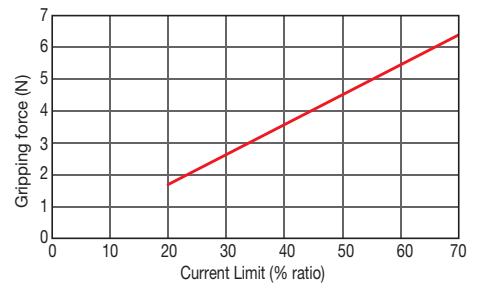

* The value of the gripping (pushing) in the graph is only reference. Please note that there is a maximum variation of about 15%.

* Please note that, when gripping (pushing), the speed is fixed at 5 degrees/s.



- (1) The maximum opening/closing speed indicates the operating speed on one side. The relative operating speed is twice this value.
- (2) The maximum gripping force is the sum of the gripping forces of both fingers, at a gripping point where there is no offset or overhang distance. The work piece weight that can be actually moved depends on the friction coefficient between the gripper fingers and the work piece, as well as on the shape of the work piece. As a rough guide, a work piece's weight should not exceed 1/10 to 1/20 of the gripping force. (See page A-77 for details.)
- (3) The rated acceleration while moving is 0.3G.

Actuator Specifications

Lead and Load Capacity

Model	Deceleration Ratio	Max. Gripping Force (N)	Stroke (deg)
RCP2-GRLS-I-20P-30-180- ① - ② - ③	30	6.4	180 (90 per side)

Legend: ① Compatible controllers ② Cable length ③ Options

Stroke and Maxi. Opening/Closing Speed

Deceleration Ratio	Stroke	180 (deg)
	30	600 (per side)

(Unit: degrees/s)

Cable List

Type	Cable Symbol
Standard Type (Robot Cables)	P (1m)
	S (3m)
	M (5m)
Special Lengths	X06 (6m) ~ X10 (10m)
	X11 (11m) ~ X15 (15m)
	X16 (16m) ~ X20 (20m)

* The standard cable is the motor-encoder integrated robot cable.

* See page A-39 for cables for maintenance.

Actuator Specifications

Item	Description
Drive System	Worm gear + helical gear
Positioning Repeatability	±0.01mm
Backlash	1 degree or less per side (constantly pressed out by a spring)
Lost Motion	1 degree or less
Guide	-
Allowable Static Load Moment	-
Weight	0.2kg
Ambient Operating Temp./Humidity	0~40°C, 85% RH or less (non-condensing)

Option List

Name	Option Code	See Page
Reversed-home	NM	→ A-33
Flange bracket	FB	→ A-26
Shaft bracket	SB	→ A-36

Dimensions

CAD drawings can be downloaded from IAI website. www.robocylinder.de



- * The opening side of the slider is the home position.
- *1 The motor-encoder cable is connected here. See page A-39 for details on cables.

For Special Orders P. A-9

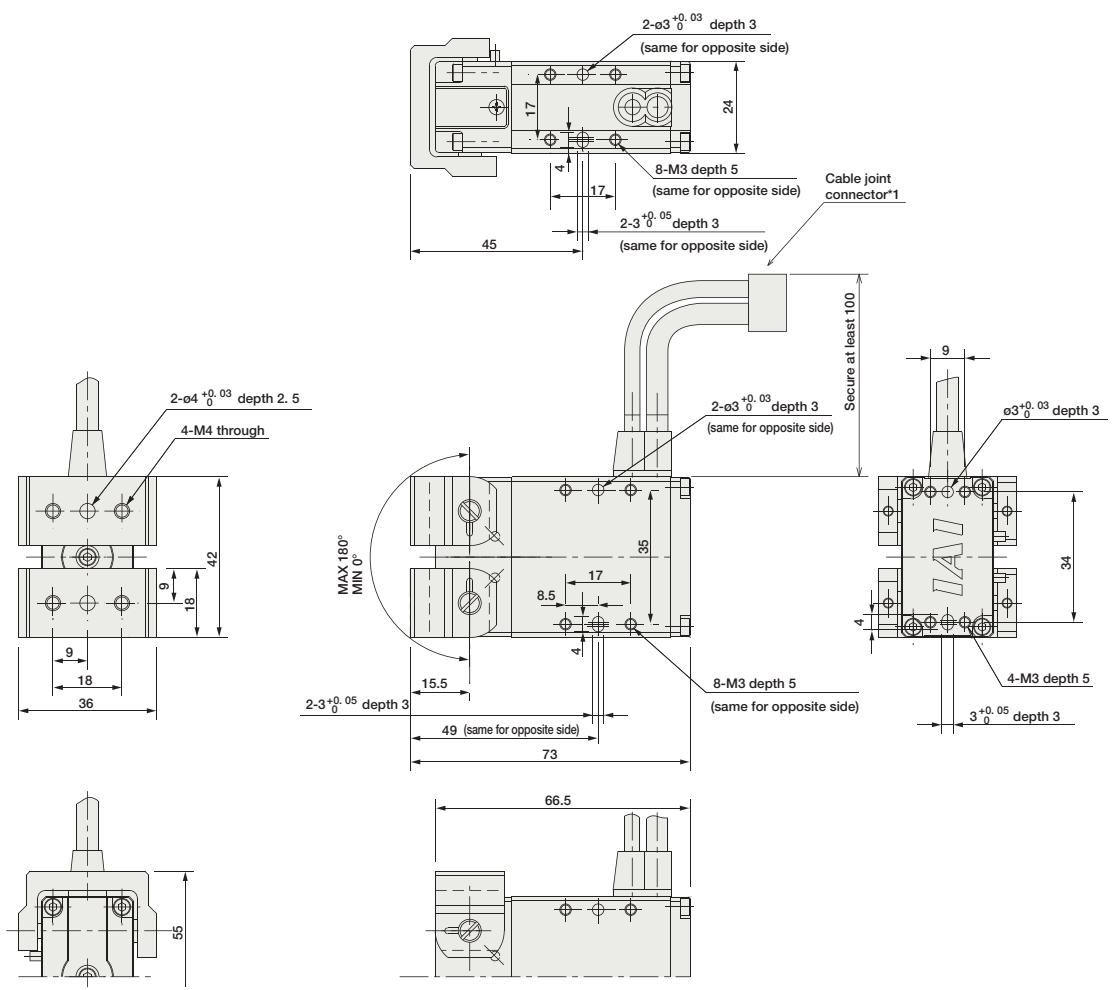

Weight (kg) 0.2

Compatible Controllers

The RCP2 series actuators can operate with the controllers below. Select the controller according to your usage.

Name	External View	Model	Description	Max. Positioning Points	Input Voltage	Power Supply Capacity	See Page
Solenoid Valve Type		PMEC-C-20PI-NP-2-2	Easy-to-use controller, even for beginners	3 points	AC115V AC230V	See P481	→ P477
		PSEP-C-20PI-NP-2-0	Operable with same signal as solenoid valve. Supports both single and double solenoid types. No homing necessary with simple absolute type.				
Splash-Proof Solenoid Valve Type		PSEP-CW-20PI-NP-2-0					
Positioner Type		PCON-C-20PI-NP-2-0	Positioning is possible for up to 512 points	512 points	DC24V	2A max.	
Safety-Compliant Positioner Type		PCON-CG-20PI-NP-2-0					
Pulse Train Input Type (Differential Line Driver)		PCON-PL-20PI-NP-2-0	Pulse train input type with differential line driver support	(-)	DC24V	2A max.	→ P525
Pulse Train Input Type (Open Collector)		PCON-PO-20PI-NP-2-0	Pulse train input type with open collector support				
Serial Communication Type		PCON-SE-20PI-NI-0-0	Dedicated to serial communication	64 points			
Field Network Type		RPOON-20P	Dedicated to field network	768 points			→ P503
Program Control Type		PSEL-C-1-20PI-NP-2-0	Programmed operation is possible. Operation is possible on up to 2 axes	1500 points			→ P557

* This is for the single-axis PSEL.

- Slider Type
- Mini
- Standard
- Controllers Integrated
- Rod Type
- Mini
- Standard
- Controllers Integrated
- Table/Arm /Flat Type
- Mini
- Standard
- Gripper/ Rotary Type
- Linear Motor Type
- Cleanroom Type
- Splash-Proof
- Controllers
- PMEC /AMEC
- PSEP /ASEP
- ROBO NET
- ERC2
- PCON
- ACON
- SCON
- PSEL
- ASEL
- SSEL
- XSEL
- Pulse Motor
- Servo Motor (24V)
- Servo Motor (230V)
- Linear Motor

RCP2-GRS

RoboCylinder 2-Finger Gripper Small Slider Type 69mm Width Pulse Motor

■ Configuration: **RCP2** - **GRS** - **I** - **20P** - **1** - **10** - - -

Series — Type — Encoder — Motor — Deceleration Ratio — Stroke — Compatible Controllers — Cable Length — Option

I: Incremental
* The Simple absolute encoder is also considered type "I".

20P: 20 □ size Pulse motor

1: 1/1 deceleration ratio

10: 10mm (5mm per side)

P1: PCON
RCON
PSEL
P3: PMEC
PSEP

N: None
P: 1m
S: 3m
M: 5m
X : Custom
R : Robot cable

SB: Shaft bracket
FB: Flange bracket

* See page Pre-35 for an explanation of the naming convention.



Technical References P. A-5

■ Gripping Force Adjustment
The gripping (pushing) force can be adjusted freely within the range of current limits of 20% to 70%.

* The gripping forces in the following diagrams indicate the sums of gripping forces of both fingers.

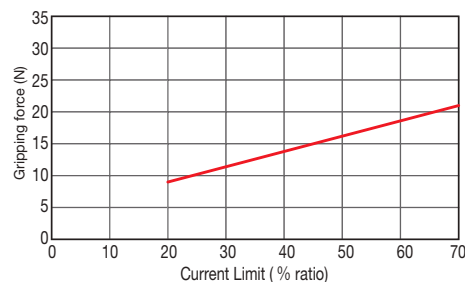

* The value of the gripping (pushing) in the graph is only reference. Please note that there is a maximum variation of about 15%.

* Please note that, when gripping (pushing), the speed is fixed at 5mm/s.



- The maximum opening/closing speed indicates the operating speed on one side. The relative operating speed is twice this value.
- The maximum gripping force is the sum of the gripping forces of both fingers, at a gripping point where there is no offset or overhang distance. The work piece weight that can be actually moved depends on the friction coefficient between the gripper fingers and the work piece, as well as on the shape of the work piece. As a rough guide, a work piece's weight should not exceed 1/10 to 1/20 of the gripping force. (See page A-74 for details.)
- The rated acceleration while moving is 0.3G.

Actuator Specifications

■ Lead and Load Capacity

Model	Deceleration Ratio	Max. Gripping Force (N)	Stroke (mm)
RCP2-GRS-I-20P-1-10-①-②-③	1	21	10 (5 per side)

Legend: ① Compatible controllers ② Cable length ③ Options

■ Stroke and Maxi. Opening/Closing Speed

Stroke Deceleration Ratio	10 (mm)
1	33.3 (per side)

(Unit: mm/s)

Cable List

Type	Cable Symbol
Standard Type	P (1m)
	S (3m)
	M (5m)
Special Lengths	X06 (6m) ~ X10 (10m)
	X11 (11m) ~ X15 (15m)
	X16 (16m) ~ X20 (20m)
Robot Cable	R01 (1m) ~ R03 (3m)
	R04 (4m) ~ R05 (5m)
	R06 (6m) ~ R10 (10m)
	R11 (11m) ~ R15 (15m)
	R16 (16m) ~ R20 (20m)

* See page A-39 for cables for maintenance.

Actuator Specifications

Item	Description
Drive System	Timing belt + trapezoidal screw (1.5 lead)
Positioning Repeatability	±0.01mm
Backlash	0.15mm or less per side (constantly pressed out by a spring)
Lost Motion	0.1mm or less per side
Guide	Cross roller guide
Allowable Static Load Moment	Ma: 6.3 N·m Mb: 6.3 N·m Mc: 7.0 N·m
Weight	0.36kg
Ambient Operating Temp./Humidity	0~40°C, 85% RH or less (non-condensing)

Option List

Name	Option Code	See Page
Flange bracket	FB	→ A-26
Shaft bracket	SB	→ A-36

Dimensions

CAD drawings can be downloaded from IAI website. www.robocylinder.de



- * The opening side of the slider is the home position.
- *1 The motor-encoder cable is connected here. See page A-39 for details on cables.

For Special Order P. A-9

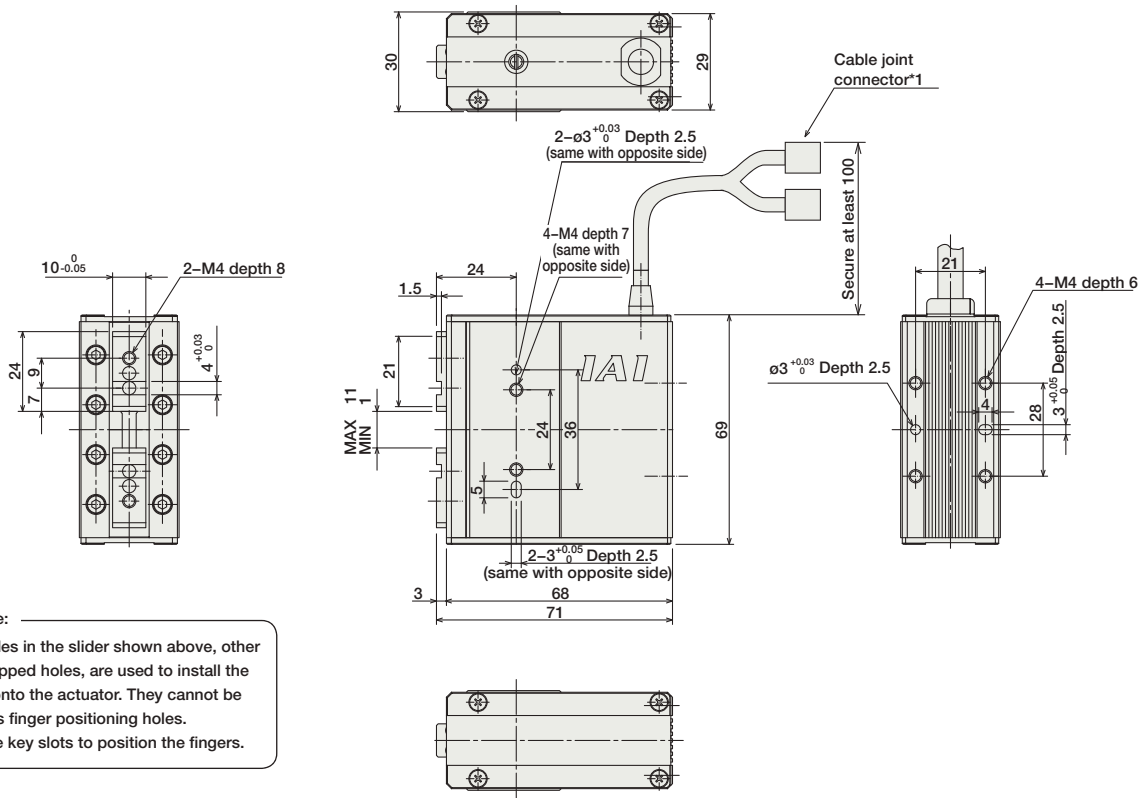

Note:
The holes in the slider shown above, other than tapped holes, are used to install the slider onto the actuator. They cannot be used as finger positioning holes. Use the key slots to position the fingers.

Weight (kg) 0.36

Compatible Controllers

The RCP2 series actuators can operate with the controllers below. Select the controller according to your usage.

Name	External View	Model	Description	Max. Positioning Points	Input Voltage	Power Supply Capacity	See Page
Solenoid Valve Type		PMEC-C-20PI-NP-2-2	Easy-to-use controller, even for beginners	3 points	AC115V AC230V	See P481	→ P477
Splash-Proof Solenoid Valve Type		PSEP-C-20PI-NP-2-0 PSEP-CW-20PI-NP-2-0	Operable with same signal as solenoid valve. Supports both single and double solenoid types. No homing necessary with simple absolute type.				→ P487
Positioner Type		PCON-C-20PI-NP-2-0	Positioning is possible for up to 512 points	512 points	DC24V	2A max.	
Safety-Compliant Positioner Type		PCON-CG-20PI-NP-2-0					
Pulse Train Input Type (Differential Line Driver)		PCON-PL-20PI-NP-2-0	Pulse train input type with differential line driver support	(-)	DC24V	2A max.	→ P525
Pulse Train Input Type (Open Collector)		PCON-PO-20PI-NP-2-0	Pulse train input type with open collector support				
Serial Communication Type		PCON-SE-20PI-N-0-0	Dedicated to serial communication	64 points			
Field Network Type		RPCON-20P	Dedicated to field network	768 points			→ P503
Program Control Type		PSEL-C-1-20PI-NP-2-0	Programmed operation is possible. Operation is possible on up to 2 axes	1500 points			→ P557

* This is for the single-axis PSEL.

- Slider Type
- Mini
- Standard
- Controllers Integrated
- Rod Type
- Mini
- Standard
- Controllers Integrated
- Table/Arm /Flat Type
- Mini
- Standard
- Gripper/ Rotary Type
- Linear Motor Type
- Cleanroom Type
- Splash-Proof
- Controllers
- PMEC /AMEC
- PSEP /ASEP
- ROBO NET
- ERC2
- PCON
- ACON
- SCON
- PSEL
- ASEL
- SSEL
- XSEL
- Pulse Motor
- Servo Motor (24V)
- Servo Motor (230V)
- Linear Motor

- Slider Type
- Mini
- Standard
- Controllers Integrated
- Rod Type
- Mini
- Standard
- Controllers Integrated
- Table/Arm /Flat Type
- Mini
- Standard
- Gripper/ Rotary Type
- Linear Motor Type
- Cleanroom Type
- Splash-Proof
- Controllers
- PMEC /AMEC
- PSEP /ASEP
- ROBO NET
- ERC2
- PCON
- ACON
- SCON
- PSEL
- ASEL
- SSEL
- XSEL
- Pulse Motor
- Servo Motor (24V)
- Servo Motor (230V)
- Linear Motor

RCP2-GRM

RoboCylinder 2-Finger Gripper Medium Slider Type 74mm Width Pulse Motor

■ Configuration: **RCP2** - **GRM** - **I** - **28P** - **1** - **14** - - -

Series — Type — Encoder — Motor — Deceleration Ratio — Stroke — Compatible Controllers — Cable Length — Option

I: Incremental
* The Simple absolute encoder is also considered type "I".

28P: 28 size Pulse motor

1: 1/1 deceleration ratio

14: 14mm (7mm per side)

P1: PCON
RPCON
PSEL

P3: PMEAC
PSEP

N: None
P: 1m
S: 3m
M: 5m
X : Custom
R : Robot cable

SB: Shaft bracket
FB: Flange bracket

* See page Pre-35 for explanation of each code that makes up the configuration name.



Technical References P. A-5

- POINT**
Notes on Selection
- (1) The maximum opening/closing speed indicates the operating speed on one side. The relative operating speed is twice this value.
 - (2) The maximum gripping force is the sum of the gripping forces of both fingers, at a gripping point where there is no offset or overhang distance. The work piece weight that can be actually moved depends on the friction coefficient between the gripper fingers and the work piece, as well as on the shape of the work pieces. As a rough guide, a work piece's weight should not exceed 1/10 to 1/20 of the gripping force. (See page A-74 for details.)
 - (3) The rated acceleration while moving is 0.3G.

■ Gripping Force Adjustment
The gripping (pushing) force can be adjusted freely within the range of current limits of 20% to 70%.

* The gripping forces in the following diagrams indicate the sums of gripping forces of both fingers.

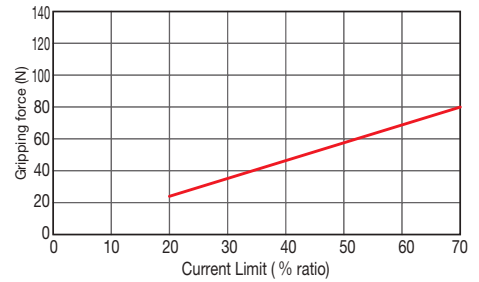

* The value of the gripping (pushing) in the graph is only reference. Please note that there is a maximum variation of about 15%.

* Please note that, when gripping (pushing), the speed is fixed at 5mm/s.

Actuator Specifications

Lead and Load Capacity

Model	Deceleration Ratio	Max. Gripping Force (N)	Stroke (mm)
RCP2-GRM-I-28P-1-14- <input type="checkbox"/> - <input type="checkbox"/> - <input type="checkbox"/>	1	80	14 (7 per side)

Legend: Compatible controllers Cable length Options

Stroke and Maxi. Opening/Closing Speed

Deceleration Ratio	Stroke	14 (mm)
	1	36.7 (per side)

(Unit: mm/s)

Cable List

Type	Cable Symbol
Standard Type	P (1m)
	S (3m)
	M (5m)
Special Lengths	X06 (6m) ~ X10 (10m)
	X11 (11m) ~ X15 (15m)
	X16 (16m) ~ X20 (20m)
Robot Cable	R01 (1m) ~ R03 (3m)
	R04 (4m) ~ R05 (5m)
	R06 (6m) ~ R10 (10m)
	R11 (11m) ~ R15 (15m)
	R16 (16m) ~ R20 (20m)

* See page A-39 for cables for maintenance.

Actuator Specifications

Item	Description
Drive System	Timing belt + trapezoidal screw (1.5 lead)
Positioning Repeatability	±0.01mm
Backlash	0.15mm or less per side (constantly pressed out by a spring)
Lost Motion	0.1mm or less per side
Guide	Cross roller guide
Allowable Static Load Moment	Ma: 6.3 N·m Mb: 6.3 N·m Mc: 8.3 N·m
Weight	0.5kg
Ambient Operating Temp./Humidity	0~40°C, 85% RH or less (non-condensing)

Option List

Name	Option Code	See Page
Flange bracket	FB	→ A-26
Shaft bracket	SB	→ A-36

Dimensions

CAD drawings can be downloaded from IAI website. www.robocylinder.de

For Special Order P. A-9



- * The opening side of the slider is the home position.
- *1 The motor-encoder cable is connected here. See page A-39 for details on cables.

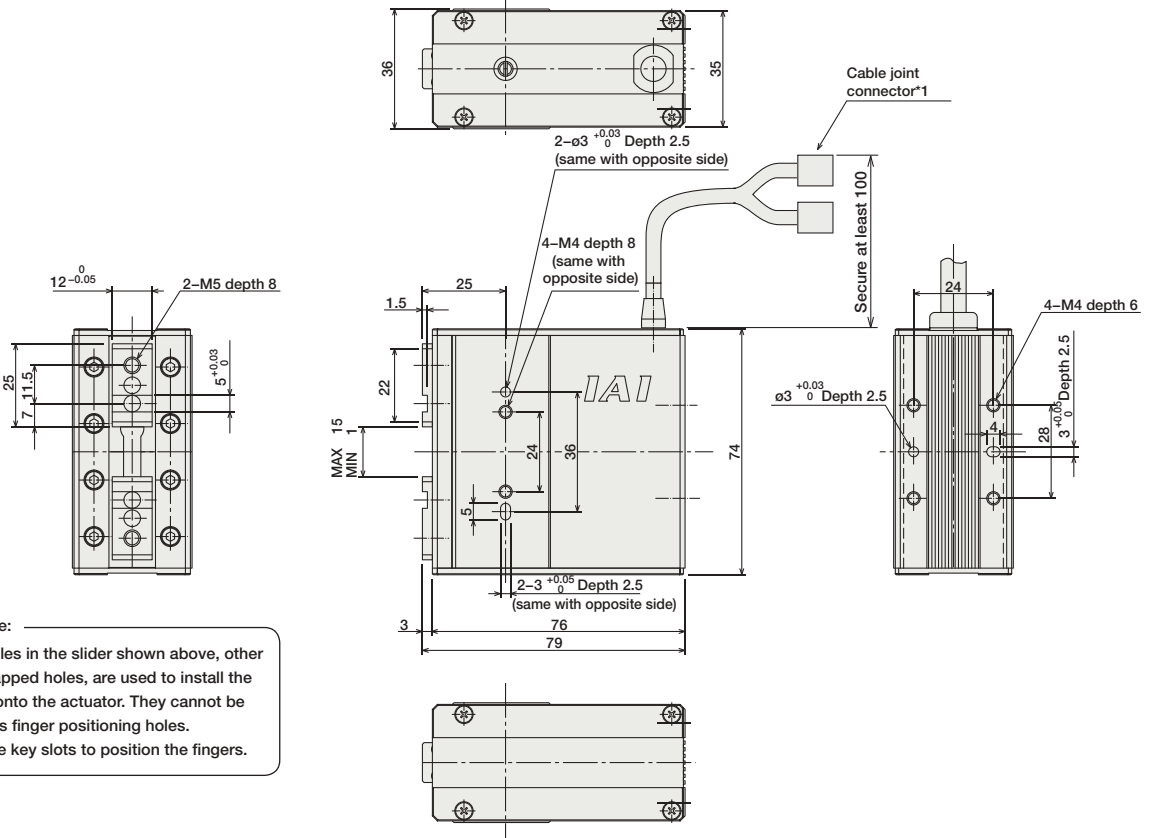

Note:
The holes in the slider shown above, other than tapped holes, are used to install the slider onto the actuator. They cannot be used as finger positioning holes. Use the key slots to position the fingers.

Weight (kg) 0.5

Compatible Controllers

The RCP2 series actuators can operate with the controllers below. Select the controller according to your usage.

Name	External View	Model	Description	Max. Positioning Points	Input Voltage	Power Supply Capacity	See Page
Solenoid Valve Type		PMEC-C-28PI-NP-2-2	Easy-to-use controller, even for beginners	3 points	AC115V AC230V	See P481	→ P477
		PSEP-C-28PI-NP-2-0	Operable with same signal as solenoid valve. Supports both single and double solenoid types.				
Splash-Proof Solenoid Valve Type		PSEP-CW-28PI-NP-2-0	No homing necessary with simple absolute type.				→ P487
Positioner Type		PCON-C-28PI-NP-2-0	Positioning is possible for up to 512 points	512 points	DC24V	2A max.	→ P525
Safety-Compliant Positioner Type		PCON-CG-28PI-NP-2-0					
Pulse Train Input Type (Differential Line Driver)		PCON-PL-28PI-NP-2-0	Pulse train input type with differential line driver support	(-)	DC24V	2A max.	→ P525
Pulse Train Input Type (Open Collector)		PCON-PO-28PI-NP-2-0	Pulse train input type with open collector support				
Serial Communication Type		PCON-SE-28PI-N-0-0	Dedicated to serial communication	64 points			
Field Network Type		RPOON-28P	Dedicated to field network	768 points			→ P503
Program Control Type		PSEL-C-1-28PI-NP-2-0	Programmed operation is possible Operation is possible on up to 2 axes	1500 points			→ P557

* This is for the single-axis PSEL.

- Slider Type
- Mini
- Standard
- Controllers Integrated
- Rod Type
- Mini
- Standard
- Controllers Integrated
- Table/Arm /Flat Type
- Mini
- Standard
- Gripper/ Rotary Type
- Linear Motor Type
- Cleanroom Type
- Splash-Proof
- Controllers
- PMEC /AMEC
- PSEP /ASEP
- ROBO NET
- ERC2
- PCON
- ACON
- SCON
- PSEL
- ASEL
- SSEL
- XSEL
- Pulse Motor
- Servo Motor (24V)
- Servo Motor (230V)
- Linear Motor

RCP2-GRHM

RoboCylinder 2-Finger Gripper Medium High-force Slider Type 116mm Width Pulse Motor

■ Configuration: **RCP2-GRHM-I-35P-2-32**

Series — Type — Encoder — Motor — Deceleration Ratio — Stroke — Compatible Controllers — Cable Length — Option

I: Incremental
* The Simple absolute encoder is also considered type "I".

35P: 35 size Pulse motor

2: 1/2 deceleration ratio

32: 32mm (16mm per side) Stroke

P1: PCON
RCON
PSEL

P3: PMEC
PSEP

N: None
P: 1m
S: 3m
M: 5m
X : Custom
R : Robot cable

Refer to the options table below.

* See page Pre-35 for explanation of each code that makes up the configuration name.



Technical References P. A-5

■ Gripping Force Adjustment
The gripping (pushing) force can be adjusted freely within the range of current limits of 20% to 70%.

* The gripping forces in the following diagrams indicate the sums of gripping forces of both fingers.

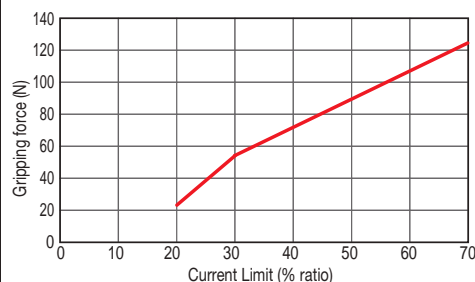

* The value of the gripping (pushing) in the graph is only reference. Please note that there is a maximum variation of about 15%.

* Please note that, when gripping (pushing), the speed is fixed at 5mm/s.

- POINT**
Notes on Selection
- (1) The maximum opening/closing speed indicates the operating speed on one side. The relative operating speed is twice this value.
 - (2) The maximum gripping force is the sum of the gripping forces of both fingers, at a gripping point where there is no offset or overhang distance. The work piece weight that can be actually moved depends on the friction coefficient between the gripper fingers and the work piece, as well as on the shape of the work pieces. As a rough guide, a work piece's weight should not exceed 1/10 to 1/20 of the gripping force. (See page A-74 for details.)
 - (3) The rated acceleration while moving is 0.3G.

Actuator Specifications

Lead and Load Capacity

Model	Deceleration Ratio	Max. Gripping Force (N)	Stroke (mm)
RCP2-GRHM-I-35P-2-32-①-②-③	2	125	32 (16 per side)

Legend: ① Compatible controllers ② Cable length ③ Options

Stroke and Maxi. Opening/Closing Speed

Deceleration Ratio	Stroke (mm)
2	100 (per side)

(Unit: mm/s)

Cable List

Type	Cable Symbol
Standard Type	P (1m)
	S (3m)
	M (5m)
Special Lengths	X06 (6m) ~ X10 (10m)
	X11 (11m) ~ X15 (15m)
	X16 (16m) ~ X20 (20m)
	R01 (1m) ~ R03 (3m)
Robot Cable	R04 (4m) ~ R05 (5m)
	R06 (6m) ~ R10 (10m)
	R11 (11m) ~ R15 (15m)
	R16 (16m) ~ R20 (20m)

* See page A-39 for cables for maintenance.

Actuator Specifications

Item	Description
Drive System	Timing belt + trapezoidal screw (2 lead)
Positioning Repeatability	±0.01mm
Backlash	0.15mm or less per side (constantly pressed out by a spring)
Lost Motion	0.2mm or less per side
Guide	Cross roller guide
Allowable Static Load Moment	Ma: 11.7 N·m Mb: 16.7 N·m Mc: 46.5 N·m
Weight	1.14kg
Ambient Operating Temp./Humidity	0~40°C, 85% RH or less (non-condensing)

Option List

Name	Option Code	See Page
Cable exit direction (Top)	CJT	→ A-25
Cable exit direction (Right)	CJR	→ A-25
Cable exit direction (Left)	CJL	→ A-25
Cable exit direction (Bottom)	CJB	→ A-25
Flange bracket	FB	→ A-26
Shaft bracket	SB	→ A-36

Dimensions

CAD drawings can be downloaded from IAI website. www.robocylinder.de



For Special Order P. A-9

- * The opening side of the slider is the home position.
- *1 The motor-encoder cable is connected here. See page A-39 for details on cables.
- *2 ME: Mechanical end

Cable Exit Direction

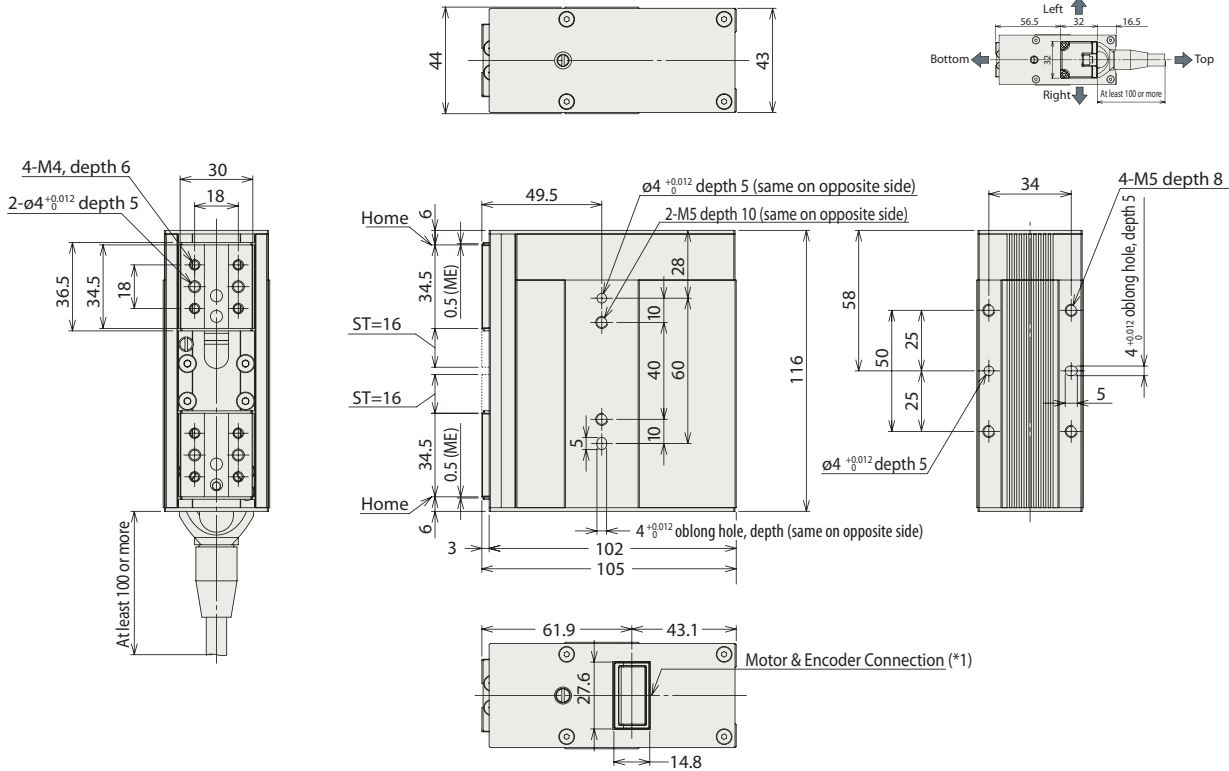
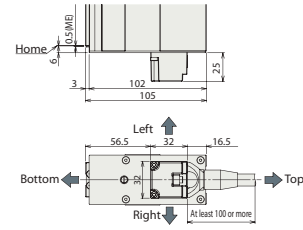

Weight (kg) 1.14

Compatible Controllers

The RCP2 series actuators can operate with the controllers below. Select the controller according to your usage.

Name	External View	Model	Description	Max. Positioning Points	Input Voltage	Power Supply Capacity	See Page
Solenoid Valve Type		PMEC-C-35PI-NP-2-2	Easy-to-use controller, even for beginners	3 points	AC115V/ AC230V	See P481	→ P477
Splash-Proof Solenoid Valve Type		PSEP-C-35PI-NP-2-0	Operable with same signal as solenoid valve. Supports both single and double solenoid types.				→ P487
Positioner Type		PCON-C-35PI-NP-2-0	Positioning is possible for up to 512 points	512 points	DC24V	2A max.	
Safety-Compliant Positioner Type		PCON-CG-35PI-NP-2-0					
Pulse Train Input Type (Differential Line Driver)		PCON-PL-35PI-NP-2-0	Pulse train input type with differential line driver support	(-)	DC24V	2A max.	→ P525
Pulse Train Input Type (Open Collector)		PCON-PO-35PI-NP-2-0	Pulse train input type with open collector support				
Serial Communication Type		PCON-SE-35PI-N-0-0	Dedicated to serial communication	64 points	DC24V	2A max.	
Field Network Type		RPCON-35P	Dedicated to field network	768 points	DC24V	2A max.	→ P503
Program Control Type		PSEL-C-1-35PI-NP-2-0	Programmed operation is possible. Operation is possible on up to 2 axes	1500 points	DC24V	2A max.	→ P557

* This is for the single-axis PSEL.

- Slider Type
- Mini
- Standard
- Controllers Integrated
- Rod Type
- Mini
- Standard
- Controllers Integrated
- Table/Arm /Flat Type
- Mini
- Standard
- Gripper/ Rotary Type
- Linear Motor Type
- Cleanroom Type
- Splash-Proof
- Controllers
- PMEC /AMEC
- PSEP /ASEP
- ROBO NET
- ERC2
- PCON
- ACON
- SCON
- PSEL
- ASEL
- SSEL
- XSEL
- Pulse Motor
- Servo Motor (24V)
- Servo Motor (230V)
- Linear Motor

RCP2-GRHB

RoboCylinder 2-Finger Gripper Large High-force Slider Type 131mm Width Pulse Motor

Configuration: **RCP2** - **GRHB** - **I** - **42P** - **2** - **40** - - -

Series — Type — Encoder — Motor — Deceleration Ratio — Stroke — Compatible Controllers — Cable Length — Option

I: Incremental
 * The Simple absolute encoder is also considered type "I".

42P: 42 size Pulse motor

2: 1/2 deceleration ratio

40: 40mm (20mm per side)

P1: PCON
 RPCON
 PSEL
 P3: PMEC
 PSEP

N: None
 P: 1m
 S: 3m
 M: 5m
 X : Custom
 R : Robot cable

Refer to the options table below.

* See page Pre-35 for explanation of each code that makes up the configuration name.



Technical References P. A-5

Gripping Force Adjustment
 The gripping (pushing) force can be adjusted freely within the range of current limits of 20% to 70%.

* The gripping forces in the following diagrams indicate the sums of gripping forces of both fingers.

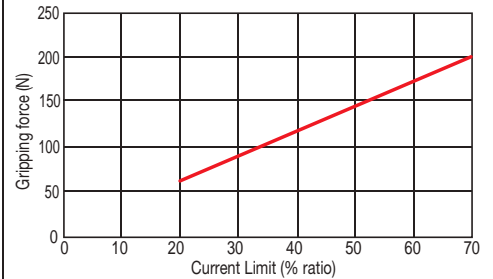

* The value of the gripping (pushing) in the graph is only reference. Please note that there is a maximum variation of about 15%.

* Please note that, when gripping (pushing), the speed is fixed at 5mm/s.

- POINT**
Notes on Selection
- The maximum opening/closing speed indicates the operating speed on one side. The relative operating speed is twice this value.
 - The maximum gripping force is the sum of the gripping forces of both fingers, at a gripping point where there is no offset or overhang distance. The work piece weight that can be actually moved depends on the friction coefficient between the gripper fingers and the work piece, as well as on the shape of the work pieces. As a rough guide, a work piece's weight should not exceed 1/10 to 1/20 of the gripping force. (See page A-74 for details.)
 - The rated acceleration while moving is 0.3G.

Actuator Specifications

Lead and Load Capacity

Model	Deceleration Ratio	Max. Gripping Force (N)	Stroke (mm)
RCP2-GRHB-I-42P-2-40- ① - ② - ③	2	200	40 (20 per side)

Legend: ① Compatible controllers ② Cable length ③ Options

Stroke and Maxi. Opening/Closing Speed

Deceleration Ratio	Stroke (mm)
2	100 (per side)

(Unit: mm/s)

Cable List

Type	Cable Symbol
Standard Type	P (1m)
	S (3m)
	M (5m)
Special Lengths	X06 (6m) ~ X10 (10m)
	X11 (11m) ~ X15 (15m)
	X16 (16m) ~ X20 (20m)
	R01 (1m) ~ R03 (3m)
Robot Cable	R04 (4m) ~ R05 (5m)
	R06 (6m) ~ R10 (10m)
	R11 (11m) ~ R15 (15m)
	R16 (16m) ~ R20 (20m)

* See page A-39 for cables for maintenance.

Actuator Specifications

Item	Description
Drive System	Timing belt + trapezoidal screw (2 lead)
Positioning Repeatability	±0.01mm
Backlash	0.15mm or less per side (constantly pressed out by a spring)
Lost Motion	0.2mm or less per side
Guide	Cross roller guide
Allowable Static Load Moment	Ma: 15.7 N·m Mb: 26.4 N·m Mc: 59.8 N·m
Weight	1.5kg
Ambient Operating Temp./Humidity	0~40°C, 85% RH or less (non-condensing)

Option List

Name	Option Code	See Page
Cable exit direction (Top)	CJT	→ A-25
Cable exit direction (Right)	CJR	→ A-25
Cable exit direction (Left)	CJL	→ A-25
Cable exit direction (Bottom)	CJB	→ A-25
Flange bracket	FB	→ A-26
Shaft bracket	SB	→ A-36

- Slider Type
- Mini
- Standard
- Controllers Integrated
- Rod Type
- Mini
- Standard
- Controllers Integrated
- Table/Arm /Flat Type
- Mini
- Standard
- Gripper/ Rotary Type
- Linear Motor Type
- Cleanroom Type
- Splash-Proof
- Controllers
- PMEC /AMEC
- PSEP /ASEP
- ROBO NET
- ERC2
- PCON
- ACON
- SCON
- PSEL
- ASEL
- SSEL
- XSEL
- Pulse Motor
- Servo Motor (24V)
- Servo Motor (230V)
- Linear Motor

RCP2-GRST RoboCylinder 2-Finger Gripper Long Stroke Slider Type 130 ~190mm Width Pulse Motor

■ Configuration: **RCP2-GRST-I-20P**

Series	Type	Encoder	Motor	Deceleration Ratio	Stroke	Compatible Controllers	Cable Length	Option
I: Incremental * The Simple absolute encoder is also considered type "I".	20P: 20 □ size Pulse motor	1: 1/1 deceleration ratio High-Speed Type 2: 1/2 deceleration ratio Standard Type	40: 40mm 60: 60mm 80: 80mm 100: 100mm	P1: PCON RPCON PSEL P3: PMECPSEP	N: None P: 1m S: 3m M: 5m X□□: Custom	See Options below * Be sure to specify the side from which you want the cable to exit (A0 or A1).		

* See page Pre-35 for an explanation of the naming convention.



Technical References P. A-5

- POINT** Notes on Selection
- The maximum opening/closing speed indicates the operating speed on one side. The relative operating speed is twice this value.
 - The maximum gripping force is the sum of the gripping forces of both fingers, at a gripping point where there is no offset or overhanging distance. The work piece weight that can be actually moved depends on the friction coefficient between the gripper fingers and the work piece, as well as on the shape of the work pieces. As a rough guide, a work piece's weight should not exceed 1/10 to 1/20 of the gripping force. (See page A-74 for details.)
 - The rated acceleration while moving is 0.3G.

■ Gripping Force Adjustment
The gripping (pushing) force can be adjusted freely within the range of current limits of 20% to 70%.

* The gripping forces in the following diagrams indicate the sums of gripping forces of both fingers.

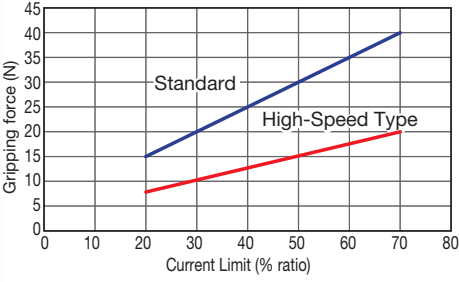

* The value of the gripping (pushing) in the graph is only reference. Please note that there is a maximum variation of about 15%.

* Please note that, when gripping (pushing), the speed is fixed at 5mm/s.

Actuator Specifications				Stroke and Maxi. Opening/Closing Speed	
■ Lead and Load Capacity				Stroke	
Model	Deceleration Ratio	Max. Gripping Force (N)	Stroke (mm)	Deceleration Ratio	40~100 (mm)
RCP2-GRST-I-20P-1-①-②-③-④	1	20	40~100 (20~50 per side) (20mm increments)	1	75 (per side)
RCP2-GRST-I-20P-2-①-②-③-④	2	40		2	34 (per side)

Legend: ① Stroke ② Compatible controller ③ Cable length ④ Options (Unit: mm/s)

Type	Cable Symbol
Standard Type (Robot Cables)	P (1m)
	S (3m)
	M (5m)
Special Lengths	X06 (6m) ~ X10 (10m)
	X11 (11m) ~ X15 (15m)
	X16 (16m) ~ X20 (20m)

* The standard cable is the motor-encoder integrated robot cable.
* See page A-39 for cables for maintenance.

Item	Description
Drive System	Timing belt + worm/rack gear
Positioning Repeatability	±0.01 mm
Backlash	0.2mm or less per side
Lost Motion	-
Guide	Linear guide
Allowable Static Load Moment	Ma: 2.93 N·m Mb: 2.93 N·m Mc: 5.0 N·m
Weight	0.51kg(40-stroke) ~ 0.66kg(100-stroke)
Ambient Operating Temp./Humidity	0~40°C, 85% RH or less (non-condensing)

Name	Option Code	See Page
Reversed-home	NM	→ A-33
Cable exiting from bottom	A0	→ A-25
Cable exiting from the side	A1	→ A-25

*Be sure to specify the side from which you want the cable to exit (A0 or A1).

Dimensions

CAD drawings can be downloaded from IAI website. www.robocylinder.de



- * The opening side of the slider is the home position.
- *1 The motor-encoder cable is connected here. See page A-39 for details on cables.

For Special Orders P. A-9

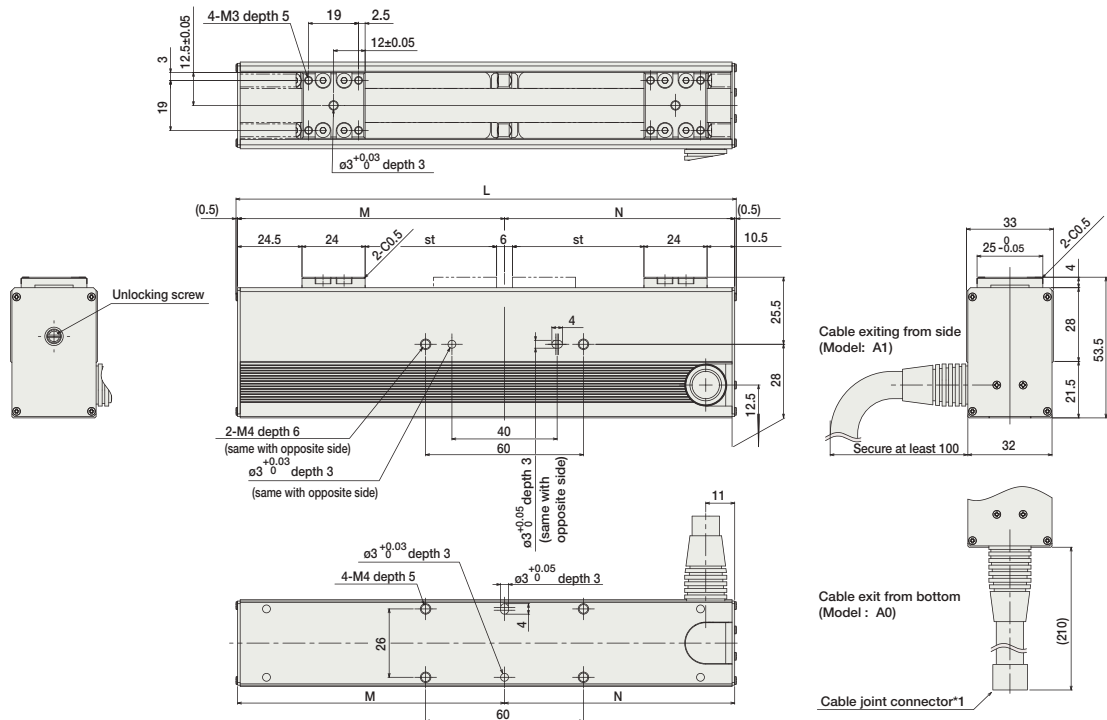

■ Dimensions and Weight by Stroke

Stroke	40	60	80	100
L	130	150	170	190
M	71.5	81.5	91.5	101.5
N	57.5	67.5	77.5	87.5
Weight (kg)	0.51	0.56	0.61	0.66

Compatible Controllers

The RCP2 series actuators can operate with the controllers below. Select the controller according to your usage.

Name	External View	Model	Description	Max. Positioning Points	Input Voltage	Power Supply Capacity	See Page
Solenoid Valve Type		PMEC-C-20PI-NP-2-2	Easy-to-use controller, even for beginners	3 points	AC115V AC230V	See P481	→ P477
Splash-Proof Solenoid Valve Type		PSEP-C-20PI-NP-2-0 PSEP-CW-20PI-NP-2-0	Operable with same signal as solenoid valve. Supports both single and double solenoid types. No homing necessary with simple absolute type.				
Positioner Type		PCON-C-20PI-NP-2-0	Positioning is possible for up to 512 points	512 points	DC24V	2A max.	
Safety-Compliant Positioner Type		PCON-CG-20PI-NP-2-0					
Pulse Train Input Type (Differential Line Driver)		PCON-PL-20PI-NP-2-0	Pulse train input type with differential line driver support	(-)	DC24V	2A max.	→ P525
Pulse Train Input Type (Open Collector)		PCON-PO-20PI-NP-2-0	Pulse train input type with open collector support				
Serial Communication Type		PCON-SE-20PI-N-0-0	Dedicated to serial communication	64 points			
Field Network Type		RPCON-20P	Dedicated to field network	768 points			→ P503
Program Control Type		PSEL-C-1-20PI-NP-2-0	Programmed operation is possible. Operation is possible on up to 2 axes	1500 points			→ P557

* This is for the single-axis PSEL.

- Slider Type
- Mini
- Standard
- Controllers Integrated
- Rod Type
- Mini
- Standard
- Controllers Integrated
- Table/Arm /Flat Type
- Mini
- Standard
- Gripper/ Rotary Type
- Linear Motor Type
- Cleanroom Type
- Splash-Proof
- Controllers
- PMEC /AMEC
- PSEP /ASEP
- ROBO NET
- ERC2
- PCON
- ACON
- SCON
- PSEL
- ASEL
- SSEL
- XSEL
- Pulse Motor
- Servo Motor (24V)
- Servo Motor (230V)
- Linear Motor

- Slider Type
- Mini
- Standard
- Controllers Integrated
- Rod Type
- Mini
- Standard
- Controllers Integrated
- Table/Arm /Flat Type
- Mini
- Standard
- Gripper/ Rotary Type
- Linear Motor Type
- Cleanroom Type
- Splash-Proof
- Controllers
- PMEC /AMEC
- PSEP /ASEP
- ROBO NET
- ERC2
- PCON
- ACON
- SCON
- PSEL
- ASEL
- SSEL
- XSEL
- Pulse Motor
- Servo Motor (24V)
- Servo Motor (230V)
- Linear Motor

RCP2-GR3LS RoboCylinder 3-Finger Gripper Lever Type 62mm Width Pulse Motor

■ Configuration: **RCP2-GR3LS-I-28P-30-19** - [] - [] - []

Series — Type — Encoder — Motor — Deceleration Ratio — Stroke — Compatible Controllers — Cable Length — Option

I: Incremental
* The Simple absolute encoder is also considered type "I".

28P: 28 □ size Pulse motor
30: 1/30 deceleration ratio
19: 19 degrees

P1: PCON
RCON
PSEL
P3: PMEC
PSEP

N: None
P: 1m
S: 3m
M: 5m
X□□: Custom
R□□: Robot cable

FB: Flange bracket
SB: Shaft bracket

* See page Pre-35 for an explanation of the naming convention.



Technical References P. A-5

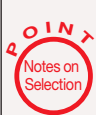

- (1) The maximum opening/closing speed indicates the operating speed on one side. The relative operating speed is twice this value.
- (2) The maximum gripping force is the sum of the gripping forces of all fingers with gripping point distance of 10mm and no overhang distance. For the actual transportable work piece weight, see explanation on the right, or page A-77.
- (3) The rated acceleration while moving is 0.3G.

■ Gripping Force vs. Current Limit Lever Type (GR3LS/GR3LM)

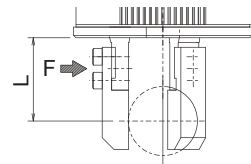

* Please note that, when gripping (pushing), the speed is fixed at 5 degrees/s.

* The values in the graph below are gripping forces at 10mm gripping point. The actual gripping force decreases inversely proportional to the distance from the opening/closing point.

You can calculate the actual gripping force by the following equation.

$$\text{Actual gripping force (type S)} = P \times 24 / (L + 14)$$

$$\text{Actual gripping force (type M)} = P \times 28.5 / (L + 18.5)$$

P=Gripping force on graph

L=Distance from finger mounting surface to the gripping point.

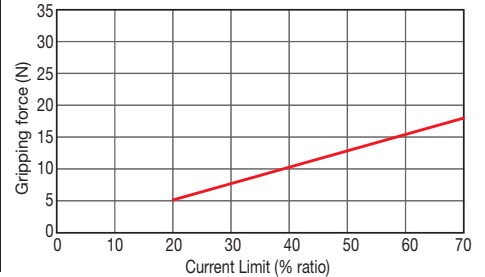

Actuator Specifications

■ Lead and Load Capacity

Model	Deceleration Ratio	Max. Gripping Force (N)	Stroke (deg)
RCP2-GR3LS-I-28P-30-19-①-②-③	30	18	19

Legend: ① Compatible controllers ② Cable length ③ Options

■ Stroke and Maxi. Opening/Closing Speed

Stroke / Deceleration Ratio	19 (deg)
30	200 (per side)

(Unit: degrees/s)

Cable List

Type	Cable Symbol
Standard Type	P (1m)
	S (3m)
	M (5m)
Special Lengths	X06 (6m) ~ X10 (10m)
	X11 (11m) ~ X15 (15m)
	X16 (16m) ~ X20 (20m)
Robot Cable	R01 (1m) ~ R03 (3m)
	R04 (4m) ~ R05 (5m)
	R06 (6m) ~ R10 (10m)
	R11 (11m) ~ R15 (15m)
	R16 (16m) ~ R20 (20m)

* See page A-39 for cables for maintenance.

Actuator Specifications

Item	Description
Drive System	Worm gear + worm wheel gear
Positioning Repeatability	±0.01 degrees
Backlash	1 degree or less per side (constantly pressed out by a spring)
Lost Motion	0.15 degrees or less per side
Weight	0.6kg
Ambient Operating Temp./Humidity	0~40°C, 85% RH or less (non-condensing)

Option List

Name	Option Code	See Page
Flange bracket	FB	→ A-26
Shaft bracket	SB	→ A-36

Dimensions

CAD drawings can be downloaded from IAI website. www.robocylinder.de



- * When homing, the actuator swings 1 degree past the home position before returning. Therefore, please watch for any interference with the surrounding objects.
- *1 The motor-encoder cable is connected here. See page A-39 for details on cables.

For Special Orders P. A-9

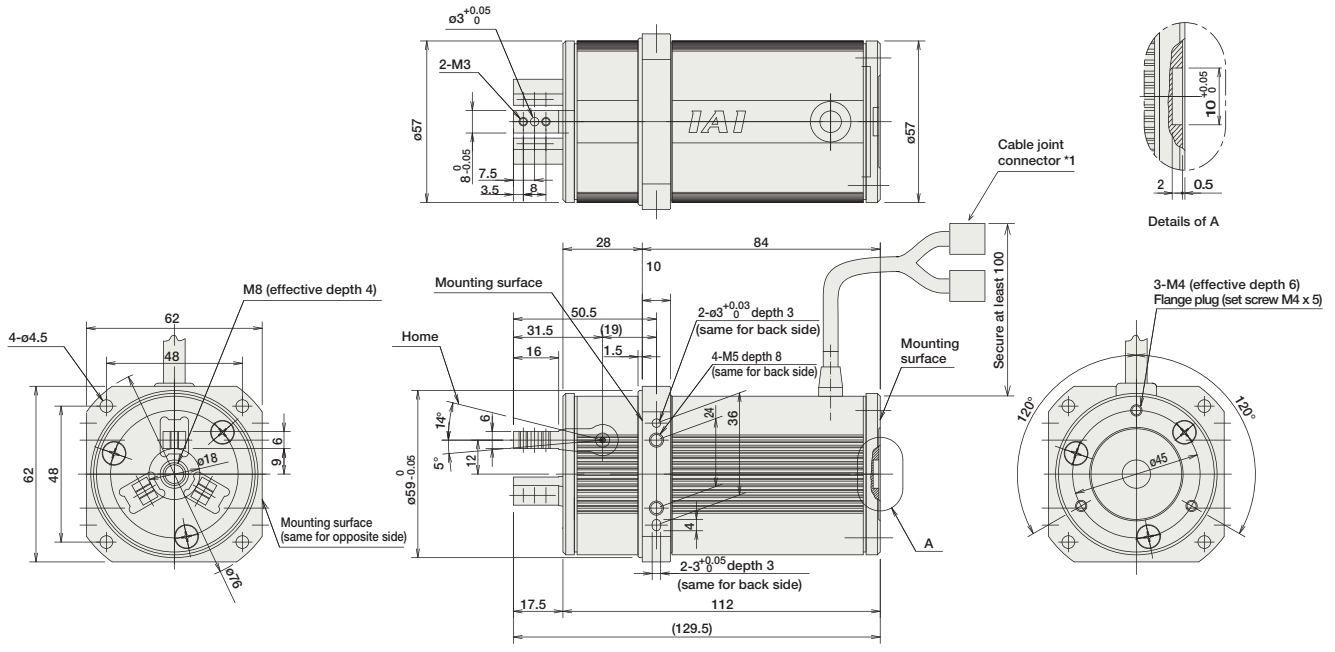

Weight (kg) 0.6

Compatible Controllers

The RCP2 series actuators can operate with the controllers below. Select the controller according to your usage.

Name	External View	Model	Description	Max. Positioning Points	Input Voltage	Power Supply Capacity	See Page
Solenoid Valve Type		PMEC-C-28PI-NP-2-2	Easy-to-use controller, even for beginners	3 points	AC115V AC230V	See P481	→ P477
Splash-Proof Solenoid Valve Type		PSEP-C-28PI-NP-2-0 PSEP-CW-28PI-NP-2-0	Operable with same signal as solenoid valve. Supports both single and double solenoid types. No homing necessary with simple absolute type.				
Positioner Type		PCON-C-28PI-NP-2-0	Positioning is possible for up to 512 points	512 points	DC24V	2A max.	
Safety-Compliant Positioner Type		PCON-CG-28PI-NP-2-0					
Pulse Train Input Type (Differential Line Driver)		PCON-PL-28PI-NP-2-0	Pulse train input type with differential line driver support	(-)	DC24V	2A max.	→ P525
Pulse Train Input Type (Open Collector)		PCON-PO-28PI-NP-2-0	Pulse train input type with open collector support				
Serial Communication Type		PCON-SE-28PI-NI-0-0	Dedicated to serial communication	64 points	DC24V	2A max.	
Field Network Type		RPCON-28P	Dedicated to field network	768 points	DC24V	2A max.	→ P503
Program Control Type		PSEL-C-1-28PI-NP-2-0	Programmed operation is possible Operation is possible on up to 2 axes	1500 points	DC24V	2A max.	→ P557

* This is for the single-axis PSEL.

- Slider Type
- Mini
- Standard
- Controllers Integrated
- Rod Type
- Mini
- Standard
- Controllers Integrated
- Table/Arm /Flat Type
- Mini
- Standard
- Gripper/ Rotary Type
- Linear Motor Type
- Cleanroom Type
- Splash-Proof
- Controllers
- PMEC /AMEC
- PSEP /ASEP
- ROBO NET
- ERC2
- PCON
- ACON
- SCON
- PSEL
- ASEL
- SSEL
- XSEL
- Pulse Motor
- Servo Motor (24V)
- Servo Motor (230V)
- Linear Motor

RCP2-GR3LM

RoboCylinder 3-Finger Gripper Lever Type 80mm Width Pulse Motor

■ Configuration: **RCP2-GR3LM-I-42P-30-19**

Series	Type	Encoder	Motor	Deceleration Ratio	Stroke	Compatible Controllers	Cable Length	Option
		I: Incremental * The Simple absolute encoder is also considered type "I".	42P: 42 □ size Pulse motor	30: 1/30 deceleration ratio	19: 19 degrees	P1: PCON RPCON PSEL P3: PMEC PSEP	N: None P: 1m S: 3m M: 5m X□□: Custom R□□: Robot cable	FB: Flange bracket SB: Shaft bracket

* See page Pre-35 for an explanation of the naming convention.



Technical References P. A-5



- (1) The maximum opening/closing speed indicates the operating speed on one side. The relative operating speed is twice this value.
- (2) The maximum gripping force is the sum of the gripping forces of all fingers with gripping point distance of 10mm and no overhang distance. For the actual transportable work piece weight, see explanation on the right, or page A-77.
- (3) The rated acceleration while moving is 0.3G.

■ Gripping Force vs. Current Limit Lever Type (GR3LS/GR3LM)

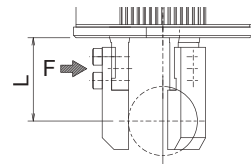

* Please note that, when gripping (pushing), the speed is fixed at 5 degrees/s.

* The values in the graph below are gripping forces at 10mm gripping point. The actual gripping force decreases inversely proportional to the distance from the opening/closing point. You can calculate the actual gripping force by the following equation.

$$\text{Actual gripping force (type S)} = P \times 24 / (L + 14)$$

$$\text{Actual gripping force (type M)} = P \times 28.5 / (L + 18.5)$$

P=Gripping force on graph

L=Distance from finger mounting surface to the gripping point.

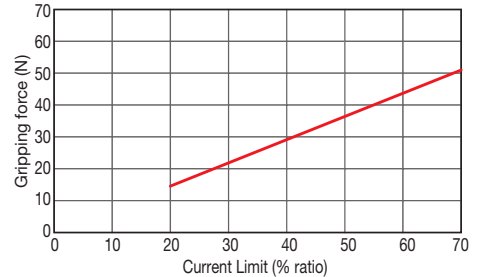

Actuator Specifications

■ Lead and Load Capacity

Model	Deceleration Ratio	Max. Gripping Force (N)	Stroke (deg)
RCP2-GR3LM-I-42P-30-19-①-②-③	30	51	19

Legend: ① Compatible controllers ② Cable length ③ Options

■ Stroke and Maxi. Opening/Closing Speed

Deceleration Ratio	Stroke	19 (deg)
	30	200 (per side)

(Unit: degrees/s)

Cable List

Type	Cable Symbol
Standard Type	P (1m)
	S (3m)
	M (5m)
Special Lengths	X06 (6m) ~ X10 (10m)
	X11 (11m) ~ X15 (15m)
	X16 (16m) ~ X20 (20m)
Robot Cable	R01 (1m) ~ R03 (3m)
	R04 (4m) ~ R05 (5m)
	R06 (6m) ~ R10 (10m)
	R11 (11m) ~ R15 (15m)
	R16 (16m) ~ R20 (20m)

* See page A-39 for cables for maintenance.

Actuator Specifications

Item	Description
Drive System	Worm gear + worm wheel gear
Positioning Repeatability	±0.01 degrees
Backlash	1 degree or less per side (constantly pressed out by a spring)
Lost Motion	0.15 degrees or less per side
Weight	1.1kg
Ambient Operating Temp./Humidity	0~40°C, 85% RH or less (non-condensing)

Option List

Name	Option Code	See Page
Flange bracket	FB	→ A-26
Shaft bracket	SB	→ A-36

Dimensions

CAD drawings can be downloaded from IAI website. www.robocylinder.de



- * When homing, the actuator swings 1 degree past the home position before returning. Therefore, please watch for any interference with the surrounding objects.
- *1 The motor-encoder cable is connected here. See page A-39 for details on cables.

For Special Orders P. A-9

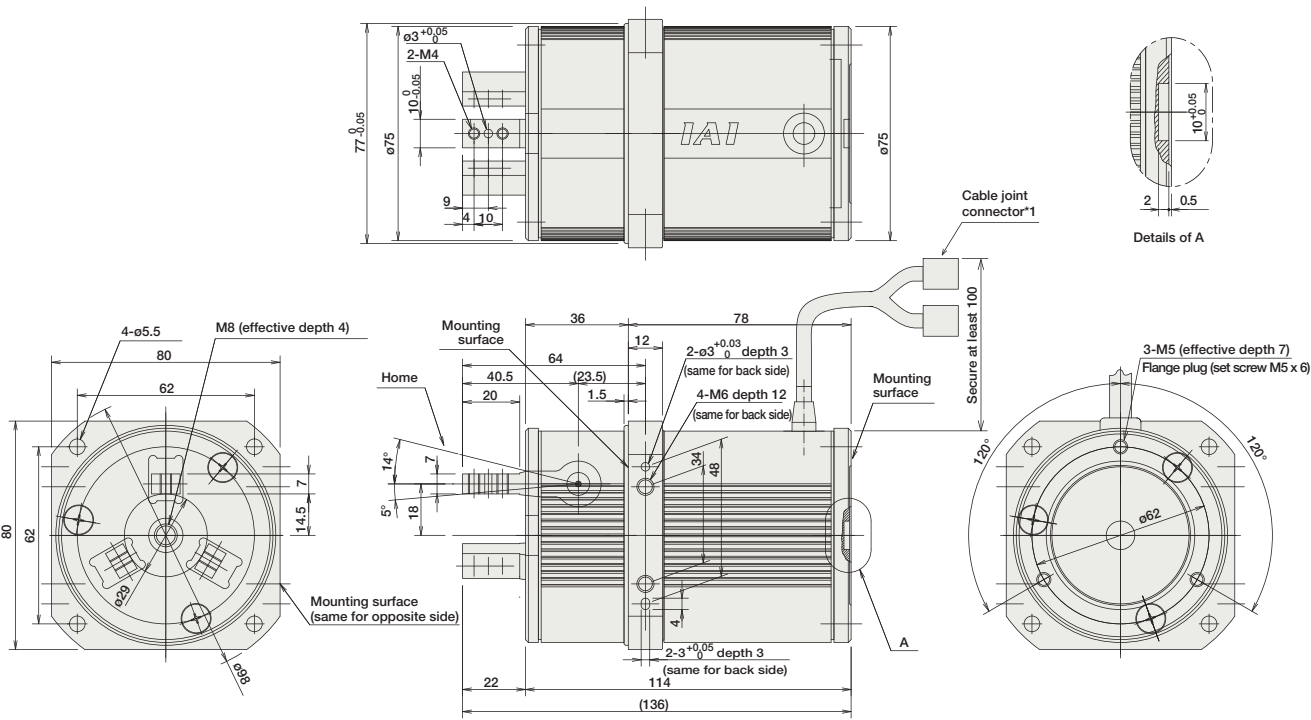

Weight (kg) 1.1

Compatible Controllers

The RCP2 series actuators can operate with the controllers below. Select the controller according to your usage.

Name	External View	Model	Description	Max. Positioning Points	Input Voltage	Power Supply Capacity	See Page
Solenoid Valve Type		PMEC-C-42PI-NP-2-2	Easy-to-use controller, even for beginners	3 points	AC115V AC230V	See P481	→ P477
Splash-Proof Solenoid Valve Type		PSEP-C-42PI-NP-2-0 PSEP-CW-42PI-NP-2-0	Operable with same signal as solenoid valve. Supports both single and double solenoid types. No homing necessary with simple absolute type.				→ P487
Positioner Type		PCON-C-42PI-NP-2-0	Positioning is possible for up to 512 points	512 points	DC24V	2A max.	
Safety-Compliant Positioner Type		PCON-CG-42PI-NP-2-0					
Pulse Train Input Type (Differential Line Driver)		PCON-PL-42PI-NP-2-0	Pulse train input type with differential line driver support	(-)	DC24V	2A max.	→ P525
Pulse Train Input Type (Open Collector)		PCON-PO-42PI-NP-2-0	Pulse train input type with open collector support				
Serial Communication Type		PCON-SE-42PI-NI-0-0	Dedicated to serial communication	64 points			
Field Network Type		RPCON-42P	Dedicated to field network	768 points			→ P503
Program Control Type		PSEL-C-1-42PI-NP-2-0	Programmed operation is possible. Operation is possible on up to 2 axes	1500 points			→ P557

* This is for the single-axis PSEL.

- Slider Type
- Mini
- Standard
- Controllers Integrated
- Rod Type
- Mini
- Standard
- Controllers Integrated
- Table/Arm /Flat Type
- Mini
- Standard
- Controllers Integrated
- Gripper/ Rotary Type
- Linear Motor Type
- Cleanroom Type
- Splash-Proof
- Controllers
- PMEC /AMEC
- PSEP /ASEP
- ROBO NET
- ERC2
- PCON
- ACON
- SCON
- PSEL
- ASEL
- SSEL
- XSEL
- Pulse Motor
- Servo Motor (24V)
- Servo Motor (230V)
- Linear Motor

- Slider Type
- Mini
- Standard
- Controllers Integrated
- Rod Type
- Mini
- Standard
- Controllers Integrated
- Table/Arm /Flat Type
- Mini
- Standard
- Gripper/ Rotary Type
- Linear Motor Type
- Cleanroom Type
- Splash-Proof
- Controllers
- PMEC /AMEC
- PSEP /ASEP
- ROBO NET
- ERC2
- PCON
- ACON
- SCON
- PSEL
- ASEL
- SSEL
- XSEL
- Pulse Motor
- Servo Motor (24V)
- Servo Motor (230V)
- Linear Motor

RCP2-GR3SS

RoboCylinder 3-Finger Gripper Slider Type 62mm Width Pulse Motor

■ Configuration: **RCP2-GR3SS-I-28P-30-10**

Series — Type — Encoder — Motor — Deceleration Ratio — Stroke — Compatible Controllers — Cable Length — Option

I: Incremental
* The Simple absolute encoder is also considered type "I".

28P: 28 □ size Pulse motor
30: 1/30 deceleration ratio

10: 10mm (5mm per side)

P1: PCON
RCON
PSEL
P3: PMEC
PSEP

N: None
P: 1m
S: 3m
M: 5m
X□□: Custom
R□□: Robot cable

FB: Flange bracket
SB: Shaft bracket

* See page Pre-35 for an explanation of the naming convention.



Technical References P. A-5

- POINT**
Notes on Selection
- (1) The maximum opening/closing speed indicates the operating speed on one side. The relative operating speed is twice this value.
 - (2) The maximum gripping force is the sum of the gripping forces of all fingers with gripping point distance of 10mm and no overhang distance. For the actual transportable work piece weight, see explanation on the right or page A-74.
 - (3) The rated acceleration while moving is 0.3G.

■ Gripping Force vs. Current Limit
Slider Type (GR3SS/GR3SM)

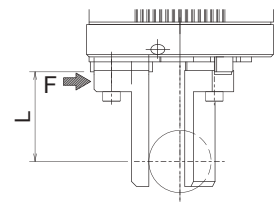

* Please keep the distance L from the finger mounting surface to the gripping point at less than the following dimensions.
GR3SS→50mm or less
GR3SM→80mm or less

* Please note that, when gripping (pushing), the speed is fixed at 5mm/s.

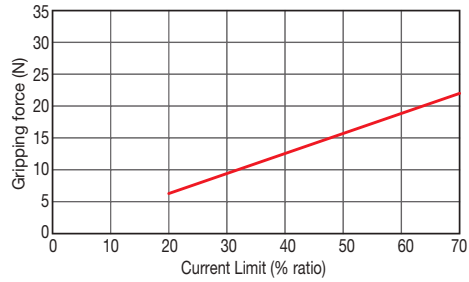

Actuator Specifications				Stroke and Maxi. Opening/Closing Speed	
■ Lead and Load Capacity				Stroke	
Model	Deceleration Ratio	Max. Gripping Force (N)	Stroke (mm)	Deceleration Ratio	10 (mm)
RCP2-GR3SS-I-28P-30-10-①-②-③	30	22	10 (5 per side)	30	40 (per side)

Legend: ① Compatible controllers ② Cable length ③ Options (Unit: mm/s)

Type	Cable Symbol
Standard Type	P (1m)
	S (3m)
	M (5m)
Special Lengths	X06 (6m) ~ X10 (10m)
	X11 (11m) ~ X15 (15m)
	X16 (16m) ~ X20 (20m)
	X21 (21m) ~ X25 (25m)
Robot Cable	R01 (1m) ~ R03 (3m)
	R04 (4m) ~ R05 (5m)
	R06 (6m) ~ R10 (10m)
	R11 (11m) ~ R15 (15m)
	R16 (16m) ~ R20 (20m)
	R21 (21m) ~ R25 (25m)

* See page A-39 for cables for maintenance.

Actuator Specifications	
Item	Description
Drive System	Worm gear + worm wheel gear
Positioning Repeatability	±0.01mm
Backlash	0.3mm or less per side (constantly pressed out by a spring)
Lost Motion	0.1mm or less per side
Guide	Cross roller guide
Allowable Static Load Moment	Ma: 3.8 N·m Mb: 3.8 N·m Mc: 3.0 N·m
Weight	0.6kg
Ambient Operating Temp./Humidity	0~40°C, 85% RH or less (non-condensing)

Option List			
Name	Option Code	See Page	
Flange bracket	FB	→ A-26	
Shaft bracket	SB	→ A-36	

Dimensions

CAD drawings can be downloaded from IAI website. www.robocylinder.de



- * When homing, the actuator swings 0.5mm past the home position before returning. Therefore, please watch for any interference with the surrounding objects.
- *1 The motor-encoder cable is connected here. See page A-39 for details on cables.

For Special Orders P. A-9

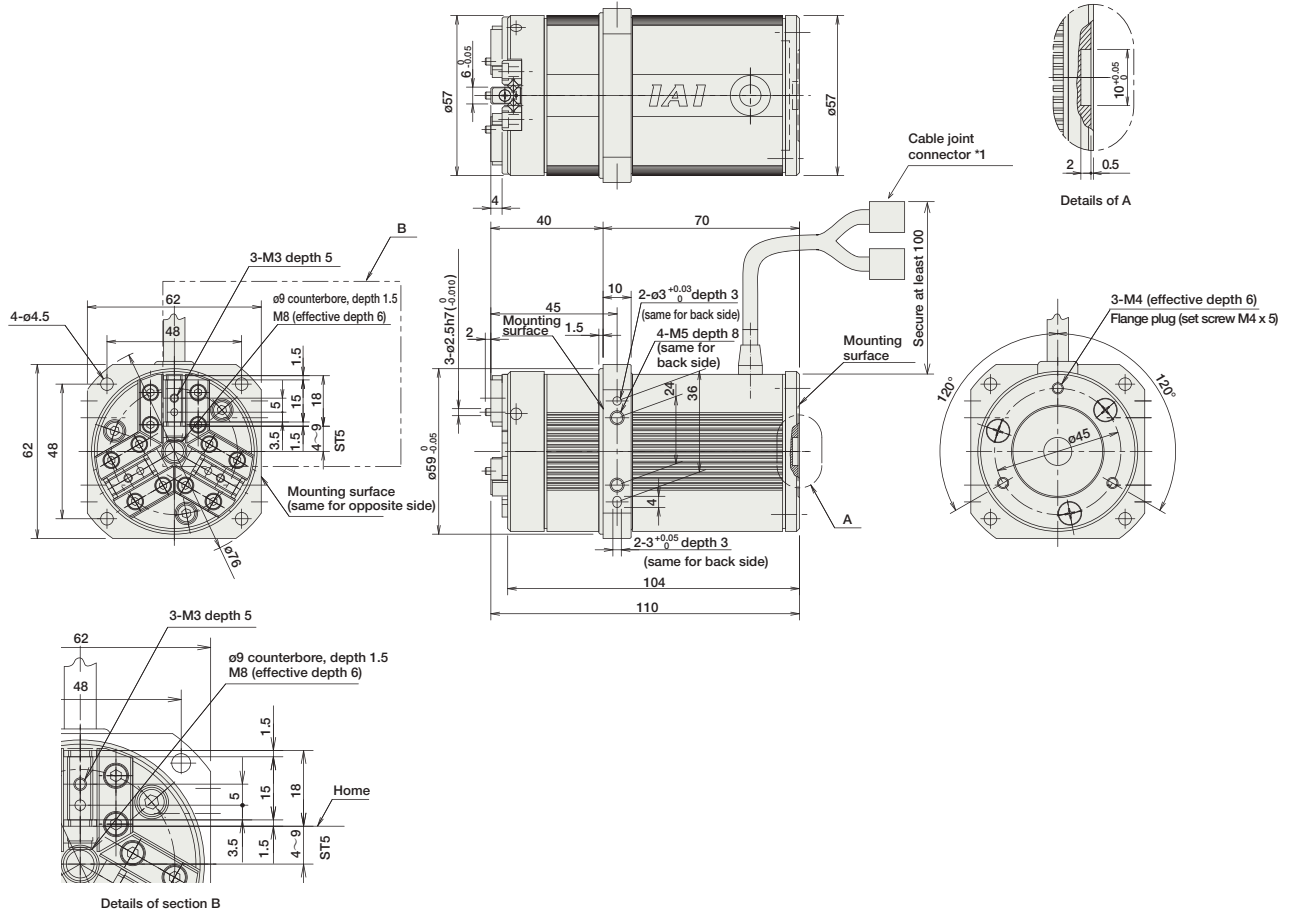

Weight (kg) 0.6

Compatible Controllers

The RCP2 series actuators can operate with the controllers below. Select the controller according to your usage.

Name	External View	Model	Description	Max. Positioning Points	Input Voltage	Power Supply Capacity	See Page
Solenoid Valve Type		PMEC-C-28PI-NP-2-2	Easy-to-use controller, even for beginners	3 points	AC115V AC230V	See P481	→ P477
		PSEP-C-28PI-NP-2-0	Operable with same signal as solenoid valve. Supports both single and double solenoid types. No homing necessary with simple absolute type.				
Splash-Proof Solenoid Valve Type		PSEP-CW-28PI-NP-2-0					
Positioner Type		PCON-C-28PI-NP-2-0	Positioning is possible for up to 512 points	512 points	DC24V	2A max.	
Safety-Compliant Positioner Type		PCON-CG-28PI-NP-2-0					
Pulse Train Input Type (Differential Line Driver)		PCON-PL-28PI-NP-2-0	Pulse train input type with differential line driver support	(-)	DC24V	2A max.	→ P525
Pulse Train Input Type (Open Collector)		PCON-PO-28PI-NP-2-0	Pulse train input type with open collector support				
Serial Communication Type		PCON-SE-28PI-NI-0-0	Dedicated to serial communication	64 points			
Field Network Type		RPCON-28P	Dedicated to field network	768 points			→ P503
Program Control Type		PSEL-C-1-28PI-NP-2-0	Programmed operation is possible. Operation is possible on up to 2 axes	1500 points			→ P557

* This is for the single-axis PSEL.

- Slider Type
- Mini
- Standard
- Controllers Integrated
- Rod Type
- Mini
- Standard
- Controllers Integrated
- Table/Arm /Flat Type
- Mini
- Standard
- Gripper/ Rotary Type
- Linear Motor Type
- Cleanroom Type
- Splash-Proof
- Controllers
- PMEC /AMEC
- PSEP /ASEP
- ROBO NET
- ERC2
- PCON
- ACON
- SCON
- PSEL
- ASEL
- SSEL
- XSEL
- Pulse Motor
- Servo Motor (24V)
- Servo Motor (230V)
- Linear Motor

RCP2-GR3SM

RoboCylinder 3-Finger Gripper Slider Type 80mm Width Pulse Motor

■ Configuration: **RCP2-GR3SM-I-42P-30-14**

Series	Type	Encoder	Motor	Deceleration Ratio	Stroke	Compatible Controllers	Cable Length	Option
		I: Incremental * The Simple absolute encoder is also considered type "I".	42P: 42 □ size Pulse motor	30: 1/30 deceleration (7mm per side) ratio	14: 14mm	P1: PCON RPCON PSEL P3: PMEC PSEP	N: None P: 1m S: 3m M: 5m X□□: Custom R□□: Robot cable	FB: Flange bracket SB: Shaft bracket

* See page Pre-35 for an explanation of the naming convention.



Technical References P. A-5



- (1) The maximum opening/closing speed indicates the operating speed on one side. The relative operating speed is twice this value.
- (2) The maximum gripping force is the sum of the gripping forces of all fingers with gripping point distance of 10mm and no overhang distance. For the actual transportable work piece weight, see explanation on the right or page A-74.
- (3) The rated acceleration while moving is 0.3G.

■ Gripping Force vs. Current Limit Slider Type (GR3SS/GR3SM)

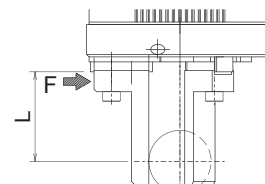

* Please keep the distance L from the finger mounting surface to the gripping point at less than the following dimensions.

GR3SS→50mm or less
GR3SM→80mm or less

* Please note that, when gripping (pushing), the speed is fixed at 5mm/s.

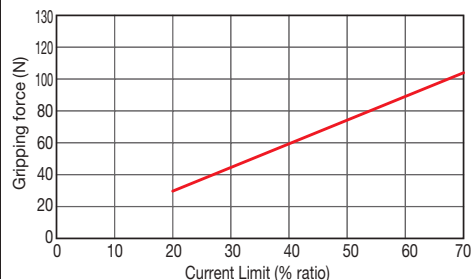

Actuator Specifications

■ Lead and Load Capacity

Model	Deceleration Ratio	Max. Gripping Force (N)	Stroke (mm)
RCP2-GR3SM-I-42P-30-14-①-②-③	30	102	14 (7 per side)

Legend: ① Compatible controllers ② Cable length ③ Options

■ Stroke and Maxi. Opening/Closing Speed

Stroke / Deceleration Ratio	14 (mm)
30	50 (per side)

(Unit: mm/s)

Cable List

Type	Cable Symbol
Standard Type	P (1m)
	S (3m)
	M (5m)
Special Lengths	X06 (6m) ~ X10 (10m)
	X11 (11m) ~ X15 (15m)
	X16 (16m) ~ X20 (20m)
Robot Cable	R01 (1m) ~ R03 (3m)
	R04 (4m) ~ R05 (5m)
	R06 (6m) ~ R10 (10m)
	R11 (11m) ~ R15 (15m)
	R16 (16m) ~ R20 (20m)

* See page A-39 for cables for maintenance.

Actuator Specifications

Item	Description
Drive System	Worm gear + worm wheel gear
Positioning Repeatability	±0.01mm
Backlash	0.3mm or less per side (constantly pressed out by a spring)
Lost Motion	0.1mm or less per side
Guide	Cross roller guide
Allowable Static Load Moment	Ma: 6.3 N·m Mb: 6.3 N·m Mc: 5.7 N·m
Weight	1.2kg
Ambient Operating Temp./Humidity	0~40°C, 85% RH or less (non-condensing)

Option List

Name	Option Code	See Page
Flange bracket	FB	→ A-26
Shaft bracket	SB	→ A-36

Dimensions

CAD drawings can be downloaded from IAI website. www.robocylinder.de



- * When homing, the actuator swings 0.5mm past the home position before returning. Therefore, please watch for any interference with the surrounding objects.
- *1 The motor-encoder cable is connected here. See page A-39 for details on cables.

For Special Orders P. A-9

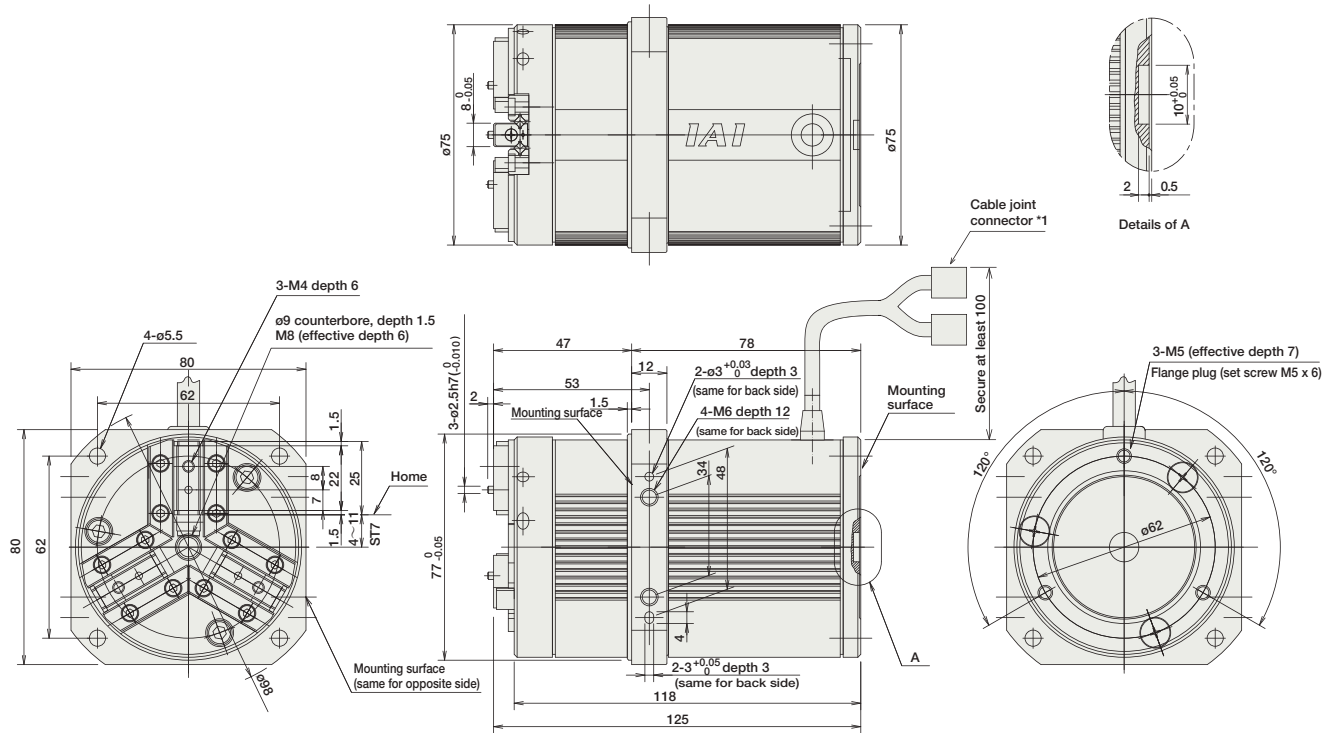

Weight (kg) 1.2

Compatible Controllers

The RCP2 series actuators can operate with the controllers below. Select the controller according to your usage.

Name	External View	Model	Description	Max. Positioning Points	Input Voltage	Power Supply Capacity	See Page
Solenoid Valve Type		PMEC-C-42PI-NP-2-2	Easy-to-use controller, even for beginners	3 points	AC115V AC230V	See P481	→ P477
		PSEP-C-42PI-NP-2-0	Operable with same signal as solenoid valve. Supports both single and double solenoid types. No homing necessary with simple absolute type.				→ P487
Splash-Proof Solenoid Valve Type		PSEP-CW-42PI-NP-2-0					
Positioner Type		PCON-C-42PI-NP-2-0	Positioning is possible for up to 512 points	512 points	DC24V	2A max.	
Safety-Compliant Positioner Type		PCON-CG-42PI-NP-2-0					
Pulse Train Input Type (Differential Line Driver)		PCON-PL-42PI-NP-2-0	Pulse train input type with differential line driver support	(-)	DC24V	2A max.	→ P525
Pulse Train Input Type (Open Collector)		PCON-PO-42PI-NP-2-0	Pulse train input type with open collector support				
Serial Communication Type		PCON-SE-42PI-N-0-0	Dedicated to serial communication	64 points			
Field Network Type		RPCON-42P	Dedicated to field network	768 points			→ P503
Program Control Type		PSEL-C-1-42PI-NP-2-0	Programmed operation is possible Operation is possible on up to 2 axes	1500 points			→ P557

* This is for the single-axis PSEL.

- Slider Type
- Mini
- Standard
- Controllers Integrated
- Rod Type
- Mini
- Standard
- Controllers Integrated
- Table/Arm /Flat Type
- Mini
- Standard
- Gripper/ Rotary Type
- Linear Motor Type
- Cleanroom Type
- Splash-Proof
- Controllers
- PMEC /AMEC
- PSEP /ASEP
- ROBO NET
- ERC2
- PCON
- ACON
- SCON
- PSEL
- ASEL
- SSEL
- XSEL
- Pulse Motor
- Servo Motor (24V)
- Servo Motor (230V)
- Linear Motor

RCP2-RTBS/RTBSL RoboCylinder Rotary Small Vertical Type 45mm Width Pulse Motor

■ Configuration: **RCP2** - - **I** - **20P** - - - - -

Series - Type - Encoder - Motor - Deceleration Ratio - Oscillation Angle - Compatible Controllers - Cable Length - Option

RTBS: 330-degree rotation
RTBSL: Multiple rotation

I: Incremental * The Simple absolute encoder is also considered type "I".

20P : 20 □ size Pulse motor

30: 1/30 deceleration ratio
45: 1/45 deceleration ratio

330: 330degrees (RTBS only)
360: 360degrees (RTBSL only)

P1: PCON
RPCON
PSEL
P3: PMECC
PSEP

N : None
P : 1m
S : 3m
M : 5m
X□□ : Custom
R□□ : Robot cable

NM :Reversed-rotation
SA: Shaft adapter
TA : Table adapter

* See page Pre-35 for an explanation of the naming convention.



Technical References P. A-5

- POINT**
Notes on Selection
- (1) The output torque decreases as the rotational speed increases. Check the output torque graph on the right to see whether the speed required for your desired motion is supported.
 - (2) The allowable moment of inertia of the rotated work piece varies with the rotational speed. Check the Allowable Moment of Inertia graph on the right to see if the moment of inertia required for your desired motion is within the allowable range.
 - (3) The rated acceleration while moving is 0.2G.
 - (4) When using index mode with multiple rotation type, PMEC/PSEP controller is not available to operate.

■ Speed vs. Load Capacity
Due to the characteristics of the Pulse Motor, the RCP2 series' load capacity decreases at high speeds. In the table below, check if your desired speed and load capacity are supported.

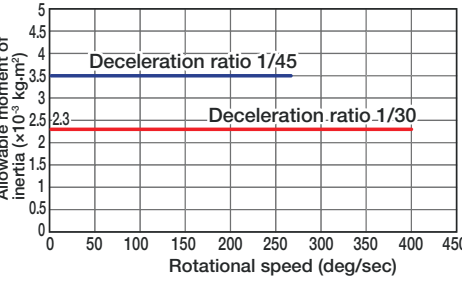
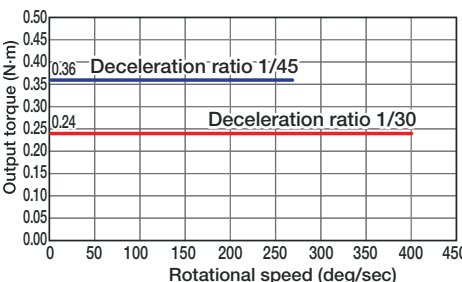

Actuator Specifications					Deceleration Ratio and Max. Speed	
■ Lead and Load Capacity					Stroke Deceleration Ratio	330/360 (deg)
Model	Deceleration Ratio	Max. Torque (N·m)	Allowable Moment of Inertia (kg·m ²)	Oscillation Angle (deg)		
RCP2-RTBS-I-20P-30-330-①-②-③	1/30	0.24	0.0023	330	1/30	400
RCP2-RTBS-I-20P-45-330-①-②-③	1/45	0.36	0.0035		1/45	266
RCP2-RTBSL-I-20P-30-360-①-②-③	1/30	0.24	0.0023	360	(Unit: degrees/s)	
RCP2-RTBSL-I-20P-45-360-①-②-③	1/45	0.36	0.0035			

Legend: ① Compatible controller ② Cable length ③ Options

Cable List	
Type	Cable Symbol
Standard Type (Robot Cables)	P (1m)
	S (3m)
	M (5m)
Special Lengths	X06 (6m) ~ X10 (10m)
	X11 (11m) ~ X15 (15m)
	X16 (16m) ~ X20 (20m)

* The standard cable is the motor-encoder integrated robot cable.
* See page A-39 for cables for maintenance.

Actuator Specifications	
Item	Description
Drive System	Hypoid gear
Positioning Repeatability	±0.05 degrees
Homing Accuracy	±0.05 degrees
Lost Motion	±0.1 degrees
Allowable Thrust Load	30N
Allowable Load Moment	3.6N·m
Weight	0.52kg
Ambient Operating Temp./Humidity	0 ~ 40°C, 85% RH or less (non-condensing)

Option List			
Name	Option Code	See Page	
Reversed-rotation	NM	→ A-33	
Shaft adapter	SA	→ A-35	
Table adapter	TA	→ A-37	

- Slider Type
- Mini
- Standard
- Controllers Integrated
- Rod Type
- Mini
- Standard
- Controllers Integrated
- Table/Arm /Flat Type
- Mini
- Standard
- Gripper/ Rotary Type
- Linear Motor Type
- Cleanroom Type
- Splash-Proof
- Controllers
- PMEC /AMEC
- PSEP /ASEP
- ROBO NET
- ERC2
- PCON
- ACON
- SCON
- PSEL
- ASEL
- SSEL
- XSEL
- Pulse Motor
- Servo Motor (24V)
- Servo Motor (230V)
- Linear Motor

Dimensions

CAD drawings can be downloaded from IAI website. www.robocylinder.de



For Special Orders P. A-9

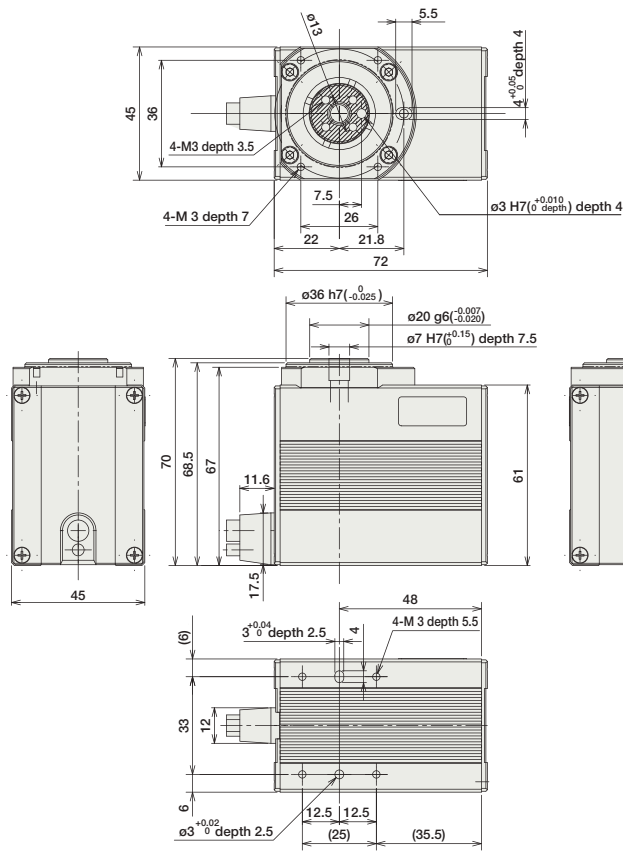

Note:
* In the 2D drawing on the left, the shaded area indicates the rotating part.

*1 The motor-encoder cable is connected here. See page A-39 for details on cables.

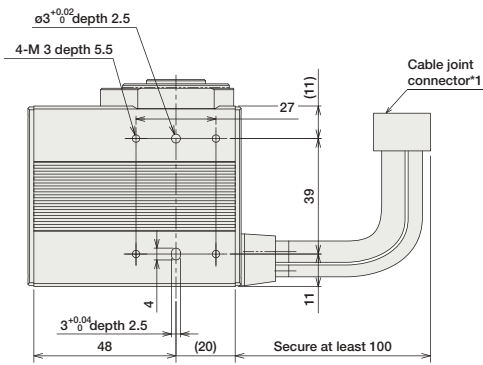

Note:
The position in the 2D drawing on the left is the home position. When homing, the actuator rotates to the left past the home position by 1 degree. Therefore please watch for any interference with the surrounding objects. The range of motion is 330 degrees clockwise, as viewed from above.

Weight (kg) 0.52

Compatible Controllers

The RCP2 series actuators can operate with the controllers below. Select the controller according to your usage.

Name	External View	Model	Description	Max. Positioning Points	Input Voltage	Power Supply Capacity	See Page
Solenoid Valve Type		PMEC-C-20PI-NP-2-2	Easy-to-use controller, even for beginners	3 points	AC115V AC230V	See P481	→ P477
		PSEP-C-20PI-NP-2-0	Operable with same signal as solenoid valve. Supports both single and double solenoid types. No homing necessary with simple absolute type.				
Splash-Proof Solenoid Valve Type		PSEP-CW-20PI-NP-2-0					
Positioner Type		PCON-C-20PI-NP-2-0	Positioning is possible for up to 512 points	512 points	DC24V	2A max.	→ P625
Safety-Compliant Positioner Type		PCON-CG-20PI-NP-2-0					
Pulse Train Input Type (Differential Line Driver)		PCON-PL-20PI-NP-2-0	Pulse train input type with differential line driver support	(-)	DC24V	2A max.	→ P625
Pulse Train Input Type (Open Collector)		PCON-PO-20PI-NP-2-0	Pulse train input type with open collector support				
Serial Communication Type		PCON-SE-20PI-N-0-0	Dedicated to serial communication	64 points			
Field Network Type		RPCON-20P	Dedicated to field network	768 points			→ P503
Program Control Type		PSEL-C-1-20PI-NP-2-0	Programmed operation is possible. Operation is possible on up to 2 axes	1500 points			→ P557

Note
* When using index mode with multiple rotation type, PMEC/PSEP controller is not available to operate.

* This is for the single-axis PSEL.

RCP2-RTCS/RTCSL

RoboCylinder Rotary Small Flat Type 72mm Width Pulse Motor

■ Configuration: **RCP2** - [] - **I** - **20P** - [] - [] - [] - [] - []

Series - Type - Encoder - Motor - Deceleration Ratio - Oscillation Angle - Compatible Controllers - Cable Length - Option

RTCS : 330 degree rotation
 RTCSL : Multi-rotational type "I".
 I: Incremental * The Simple absolute encoder is also considered type "I".
 28P : 28 □ size Pulse motor
 30: 1/30 deceleration ratio
 45: 1/45 deceleration ratio
 330: 330degrees (RTCS only)
 360: 360degrees (RTCSL only)
 P1: PCON
 P2: PCON
 P3: PMEC
 PSEP
 N : None
 P : 1m
 S : 3m
 M : 5m
 X□□ : Custom
 R□□ : Robot cable
 NM :Reversed-rotation
 SA: Shaft adapter
 TA : Table adapter

* See page Pre-35 for an explanation of the naming convention.



Technical References P. A-5



- (1) The output torque decreases as the rotational speed increases. Check the output torque graph on the right to see whether the speed required for your desired motion is supported.
- (2) The allowable moment of inertia of the rotated work piece varies with the rotational speed. Check the Allowable Moment of Inertia graph on the right to see if the moment of inertia required for your desired motion is within the allowable range.
- (3) The rated acceleration while moving is 0.2G.
- (4) When using index mode with multiple rotation type, PMEC/PSEP controller is not available to operate.

■ Speed vs. Load Capacity
 Due to the characteristics of the Pulse motor, the RCP2 series' load capacity decreases at high speeds. In the table below, check if your desired speed and load capacity are supported.

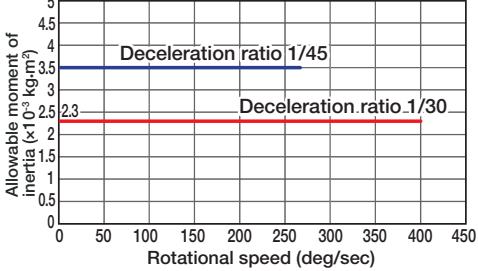
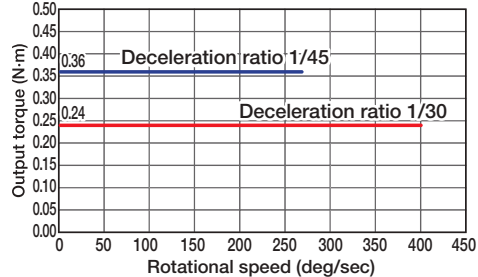

Actuator Specifications

■ Lead and Load Capacity

Model	Deceleration Ratio	Max. Torque (N·m)	Allowable Moment of Inertia (kg·m ²)	Oscillation Angle (deg)
RCP2-RTCS-I-20P-30-330-①-②-③	1/30	0.24	0.0023	330
RCP2-RTCS-I-20P-45-330-①-②-③	1/45	0.36	0.0035	
RCP2-RTCSL-I-20P-30-360-①-②-③	1/30	0.24	0.0023	360
RCP2-RTCSL-I-20P-45-360-①-②-③	1/45	0.36	0.0035	

Legend: ① Compatible controller ② Cable length ③ Options

■ Deceleration Ratio and Max. Speed

Deceleration Ratio	330/360 (deg)
1/30	400
1/45	266

(Unit: degrees/s)

Cable List

Type	Cable Symbol
Standard Type (Robot Cables)	P (1m)
	S (3m)
	M (5m)
Special Lengths	X06 (6m) ~ X10 (10m)
	X11 (11m) ~ X15 (15m)
	X16 (16m) ~ X20 (20m)

* The standard cable is the motor-encoder integrated robot cable.

* See page A-39 for cables for maintenance.

Actuator Specifications

Item	Description
Drive System	Hypoid gear
Positioning Repeatability	±0.05 degrees
Homing Accuracy	±0.05 degrees
Lost Motion	±0.1 degrees
Allowable Thrust Load	30N
Allowable Load Moment	3.6N·m
Weight	0.52kg
Ambient Operating Temp./Humidity	0 ~ 40°C, 85% RH or less (non-condensing)

Option List

Name	Option Code	See Page
Reversed-rotation	NM	→ A-33
Shaft adapter	SA	→ A-35
Table adapter	TA	→ A-37

Dimensions

CAD drawings can be downloaded from IAI website. www.robocylinder.de



For Special Orders P. A-9

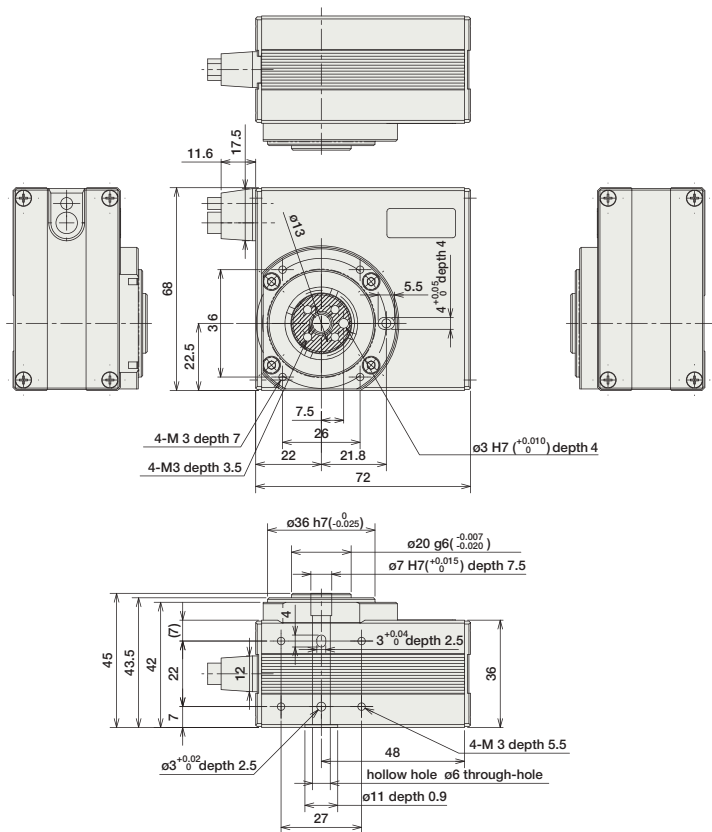

Note:
* In the 2D drawing on the left, the shaded area indicates the rotating part.

*1 The motor-encoder cable is connected here. See page A-39 for details on cables.

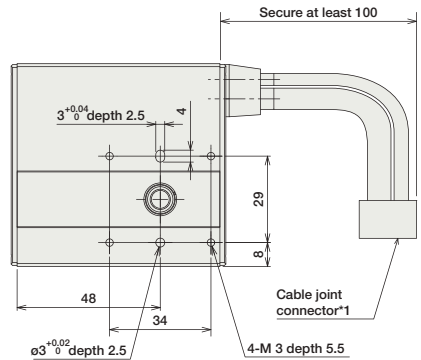

Note:
The position in the 2D drawing on the left is the home position. When homing, the actuator rotates to the left past the home position by 1 degree. Therefore please watch for any interference with the surrounding objects. The range of motion is 330 degrees clockwise, as viewed from above.

Weight (kg) 0.48

Compatible Controllers

The RCP2 series actuators can operate with the controllers below. Select the controller according to your usage.

Name	External View	Model	Description	Max. Positioning Points	Input Voltage	Power Supply Capacity	See Page
Solenoid Valve Type		PMEC-C-20PI-NP-2-2	Easy-to-use controller, even for beginners	3 points	AC115V AC230V	See P481	→ P477
		PSEP-C-20PI-NP-2-0	Operable with same signal as solenoid valve. Supports both single and double solenoid types. No homing necessary with simple absolute type.				→ P487
Splash-Proof Solenoid Valve Type		PSEP-CW-20PI-NP-2-0					
Positioner Type		PCON-C-20PI-NP-2-0	Positioning is possible for up to 512 points	512 points	DC24V	2A max.	
Safety-Compliant Positioner Type		PCON-CG-20PI-NP-2-0					
Pulse Train Input Type (Differential Line Driver)		PCON-PL-20PI-NP-2-0	Pulse train input type with differential line driver support	(-)	DC24V	2A max.	→ P525
Pulse Train Input Type (Open Collector)		PCON-PO-20PI-NP-2-0	Pulse train input type with open collector support				
Serial Communication Type		PCON-SE-20PI-N-0-0	Dedicated to serial communication	64 points			
Field Network Type		RPCON-20P	Dedicated to field network	768 points			→ P503
Program Control Type		PSEL-C-1-20PI-NP-2-0	Programmed operation is possible. Operation is possible on up to 2 axes	1500 points			→ P557

Note
* When using index mode with multiple rotation type, PMEC/PSEP controller is not available to operate.

* This is for the single-axis PSEL.

- Slider Type
- Mini
- Standard
- Controllers Integrated
- Rod Type
- Mini
- Standard
- Controllers Integrated
- Table/Arm /Flat Type
- Mini
- Standard
- Gripper/ Rotary Type
- Linear Motor Type
- Cleanroom Type
- Splash-Proof
- Controllers
- PMEC /AMEC
- PSEP /ASEP
- ROBO NET
- ERC2
- PCON
- ACON
- SCON
- PSEL
- ASEL
- SSEL
- XSEL
- Pulse Motor
- Servo Motor (24V)
- Servo Motor (230V)
- Linear Motor

RCP2-RTB/RTBL

RoboCylinder Rotary Medium Vertical Type 50mm Width Pulse Motor

■ Configuration: **RCP2** - [] - **I** - **28P** - [] - [] - [] - [] - []

Series - Type - Encoder - Motor - Deceleration Ratio - Oscillation Angle - Compatible Controllers - Cable Length - Option

RTB : 330-degree rotation
 RTBL: Multi-rotational

I: Incremental * The Simple absolute encoder is also considered type "I".

28P : 28 □ size Pulse motor

20: 1/20 deceleration ratio
 30: 1/30 deceleration ratio

330: 330degrees (RTB only)
 360: 360degrees (RTBL only)

P1: PCON
 PSEL
 P3: PMEC
 PSEP

N : None
 P : 1m
 S : 3m
 M : 5m
 X □ □ : Custom
 R □ □ : Robot cable

NM :Reversed-rotation
 SA: Shaft adapter
 TA : Table adapter

* See page Pre-35 for an explanation of the naming convention.



Technical References P. A-5

■ Speed vs. Load Capacity
 Due to the characteristics of the Pulse motor, the RCP2 series' load capacity decreases at high speeds. In the table below, check if your desired speed and load capacity are supported.

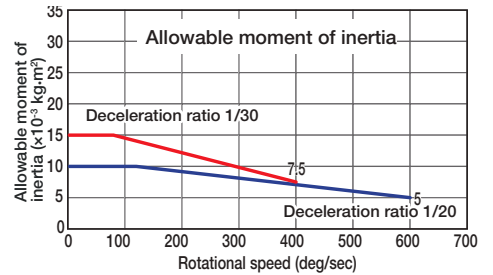
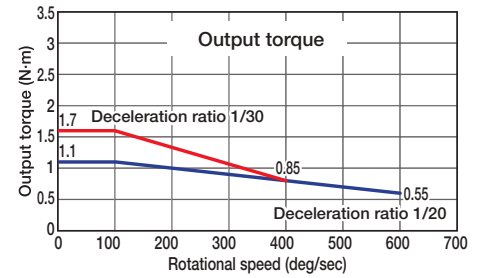

- POINT** Notes on Selection
- The output torque decreases as the rotational speed increases. Check the output torque graph on the right to see whether the speed required for your desired motion is supported.
 - The allowable moment of inertia of the rotated work piece varies with the rotational speed. Check the Allowable Moment of Inertia graph on the right to see if the moment of inertia required for your desired motion is within the allowable range.
 - The rated acceleration while moving is 0.3G.
 - When using index mode with multiple rotation type, PMEC/PSEP controller is not available to operate.

Actuator Specifications

Lead and Load Capacity

Model	Deceleration Ratio	Max. Torque (N-m)	Allowable Moment of Inertia (kg-m ²)	Oscillation Angle (deg)
RCP2-RTB-I-28P-20-330-①-②-③	1/20	1.1	0.01	330
RCP2-RTB-I-28P-30-330-①-②-③	1/30	1.7	0.015	
RCP2-RTBL-I-28P-20-360-①-②-③	1/20	1.1	0.01	360
RCP2-RTBL-I-28P-30-360-①-②-③	1/30	1.7	0.015	

Legend: ① Compatible controller ② Cable length ③ Options

Deceleration Ratio and Max. Speed

Deceleration Ratio	Stroke 330/360 (deg)
1/20	600
1/30	400

(Unit: degrees/s)

Cable List

Type	Cable Symbol
Standard Type	P (1m)
	S (3m)
	M (5m)
Special Lengths	X06 (6m) ~ X10 (10m)
	X11 (11m) ~ X15 (15m)
	X16 (16m) ~ X20 (20m)
	X21 (21m) ~ X25 (25m)
Robot Cable	R01 (1m) ~ R03 (3m)
	R04 (4m) ~ R05 (5m)
	R06 (6m) ~ R10 (10m)
	R11 (11m) ~ R15 (15m)
	R16 (16m) ~ R20 (20m)
	R21 (21m) ~ R25 (25m)

* See page A-39 for cables for maintenance.

Actuator Specifications

Item	Description
Drive System	Hypoid gear
Positioning Repeatability	±0.01 degrees
Homing Accuracy	±0.01 degrees
Lost Motion	±0.1 degrees
Allowable Thrust Load	50N
Allowable Load Moment	3.9 N-m
Weight	0.86kg
Ambient Operating Temp./Humidity	0 ~ 40°C, 85% RH or less (non-condensing)

Option List

Name	Option Code	See Page
Reversed-rotation	NM	→ A-33
Shaft adapter	SA	→ A-35
Table adapter	TA	→ A-37

Dimensions

CAD drawings can be downloaded from IAI website. www.robocylinder.de

For Special Orders P. A-9



Note:
* In the drawing on the right, the shaded area indicates the rotating part.

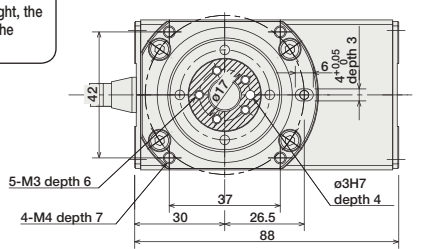

Note:
The position in the drawing on the left is the home position. When homing, the actuator rotates to the left past the home position by 1 degree. Therefore please watch for any interference with the surrounding objects. The range of motion is 330 degrees clockwise, as viewed from above.

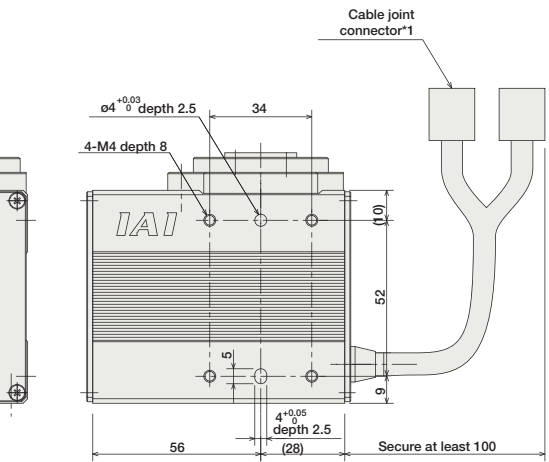
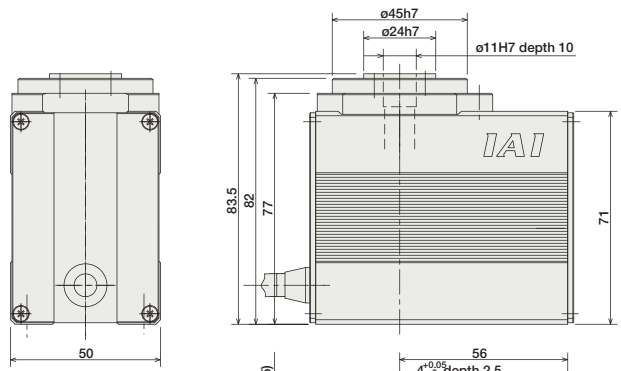

* The bend radius R of the cable is the same as other models.

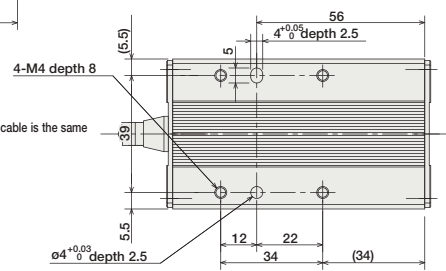

*1 The motor-encoder cable is connected here. See page A-39 for details on cables.

Weight (kg) 0.86

Compatible Controllers

The RCP2 series actuators can operate with the controllers below. Select the controller according to your usage.

Name	External View	Model	Description	Max. Positioning Points	Input Voltage	Power Supply Capacity	See Page
Solenoid Valve Type		PMEC-C-28PI-NP-2-2	Easy-to-use controller, even for beginners	3 points	AC115V AC230V	See P481	→ P477
Splash-Proof Solenoid Valve Type		PSEP-C-28PI-NP-2-0	Operable with same signal as solenoid valve. Supports both single and double solenoid types. No homing necessary with simple absolute type.				
Positioner Type		PCON-C-28PI-NP-2-0	Positioning is possible for up to 512 points	512 points	DC24V	2A max.	
Safety-Compliant Positioner Type		PCON-CG-28PI-NP-2-0					
Pulse Train Input Type (Differential Line Driver)		PCON-PL-28PI-NP-2-0	Pulse train input type with differential line driver support	(-)	DC24V	2A max.	→ P525
Pulse Train Input Type (Open Collector)		PCON-PO-28PI-NP-2-0	Pulse train input type with open collector support				
Serial Communication Type		PCON-SE-28PI-N-0-0	Dedicated to serial communication	64 points			
Field Network Type		RPCON-28P	Dedicated to field network	768 points			→ P503
Program Control Type		PSEL-C-1-28PI-NP-2-0	Programmed operation is possible. Operation is possible on up to 2 axes	1500 points			→ P557

Note
* When using index mode with multiple rotation type, PMEC/PSEP controller is not available to operate.

* This is for the single-axis PSEL.

- Slider Type
- Mini
- Standard
- Controllers Integrated
- Rod Type
- Mini
- Standard
- Controllers Integrated
- Table/Arm /Flat Type
- Mini
- Standard
- Gripper/ Rotary Type
- Linear Motor Type
- Cleanroom Type
- Splash-Proof
- Controllers
- PMEC /AMEC
- PSEP /ASEP
- ROBO NET
- ERC2
- PCON
- ACON
- SCON
- PSEL
- ASEL
- SSEL
- XSEL
- Pulse Motor
- Servo Motor (24V)
- Servo Motor (230V)
- Linear Motor

- Slider Type
- Mini
- Standard
- Controllers Integrated
- Rod Type
- Mini
- Standard
- Controllers Integrated
- Table/Arm /Flat Type
- Mini
- Standard
- Gripper/ Rotary Type
- Linear Motor Type
- Cleanroom Type
- Splash-Proof
- Controllers
- PMEC /AMEC
- PSEP /ASEP
- ROBO NET
- ERC2
- PCON
- ACON
- SCON
- PSEL
- ASEL
- SSEL
- XSEL
- Pulse Motor
- Servo Motor (24V)
- Servo Motor (230V)
- Linear Motor

RCP2-RTC/RTCL

RoboCylinder Rotary Medium Flat Type 88mm Width Pulse Motor

■ Configuration: **RCP2** - [] - **I** - **28P** - [] - [] - [] - [] - []

Series Type Encoder Motor Deceleration Ratio Oscillation Angle Compatible Controllers Cable Length Option

RTC: 330-degree rotation
 I: Incremental * The Simple absolute encoder is also considered type "I".
 RTCL: Multi-rotational

28P: 28 size Pulse motor
 20: 1/20 deceleration ratio
 30: 1/30 deceleration ratio

330: 330degrees (RTC only)
 360: 360degrees (RTCL only)

P1: PCON
 RCON
 PSEL
 P3: PMECP
 PSEP

N: None
 P: 1m
 S: 3m
 M: 5m
 X [] : Custom
 R [] : Robot cable

NM: Reversed-rotation
 SA: Shaft adapter
 TA: Table adapter

* See page Pre-35 for an explanation of the naming convention.



Technical References P. A-5

- POINT** Notes on Selection
- (1) The output torque decreases as the rotational speed increases. Check the output torque graph on the right to see whether the speed required for your desired motion is supported.
 - (2) The allowable moment of inertia of the rotated work piece varies with the rotational speed. Check the Allowable Moment of Inertia graph on the right to see if the moment of inertia required for your desired motion is within the allowable range.
 - (3) The rated acceleration while moving is 0.3G.
 - (4) When using index mode with multiple rotation type, PMEC/PSEP controller is not available to operate.

Speed vs. Load Capacity

Due to the characteristics of the Pulse motor, the RCP2 series' load capacity decreases at high speeds. In the table below, check if your desired speed and load capacity are supported.

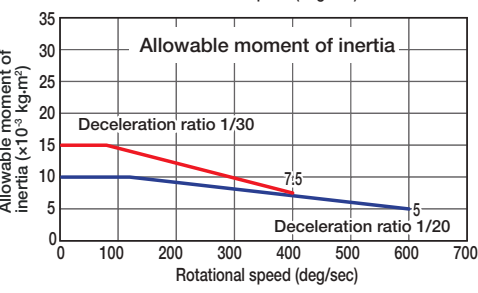
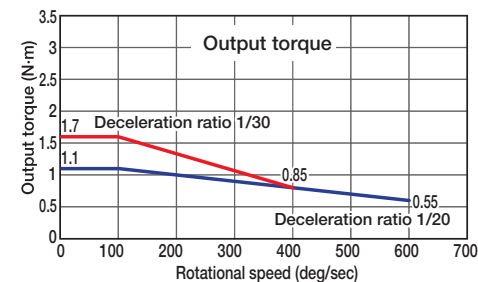

Actuator Specifications					Deceleration Ratio and Max. Speed	
■ Lead and Load Capacity					Stroke Deceleration Ratio	330/360 (deg)
Model	Deceleration Ratio	Max. Torque (N·m)	Allowable Moment of Inertia (kg·m ²)	Oscillation Angle (deg)		
RCP2-RTC-I-28P-20-330-①-②-③	1/20	1.1	0.01	330	1/20	600
RCP2-RTC-I-28P-30-330-①-②-③	1/30	1.7	0.015		1/30	400
RCP2-RTCL-I-28P-20-360-①-②-③	1/20	1.1	0.01	360	(Unit: degrees/s)	
RCP2-RTCL-I-28P-30-360-①-②-③	1/30	1.7	0.015			

Legend: ① Compatible controller ② Cable length ③ Options

Cable List	
Type	Cable Symbol
Standard Type	P (1m)
	S (3m)
	M (5m)
Special Lengths	X06 (6m) ~ X10 (10m)
	X11 (11m) ~ X15 (15m)
	X16 (16m) ~ X20 (20m)
	X21 (21m) ~ X25 (25m)
Robot Cable	R01 (1m) ~ R03 (3m)
	R04 (4m) ~ R05 (5m)
	R06 (6m) ~ R10 (10m)
	R11 (11m) ~ R15 (15m)
	R16 (16m) ~ R20 (20m)
	R21 (21m) ~ R25 (25m)

* See page A-39 for cables for maintenance.

Actuator Specifications	
Item	Description
Drive System	Hypoid gear
Positioning Repeatability	±0.01 degrees
Homing Accuracy	±0.01 degrees
Lost Motion	±0.1 degrees
Allowable Thrust Load	50N
Allowable Load Moment	3.9 N·m
Weight	0.92kg
Ambient Operating Temp./Humidity	0 ~ 40°C, 85% RH or less (non-condensing)

Option List			
Name	Option Code	See Page	
Reversed-rotation	NM	→ A-33	
Shaft adapter	SA	→ A-35	
Table adapter	TA	→ A-37	

Dimensions

CAD drawings can be downloaded from IAI website. www.robocylinder.de



For Special Orders P. A-9

Note:

* In the drawing on the right, the shaded area indicates the rotating part.

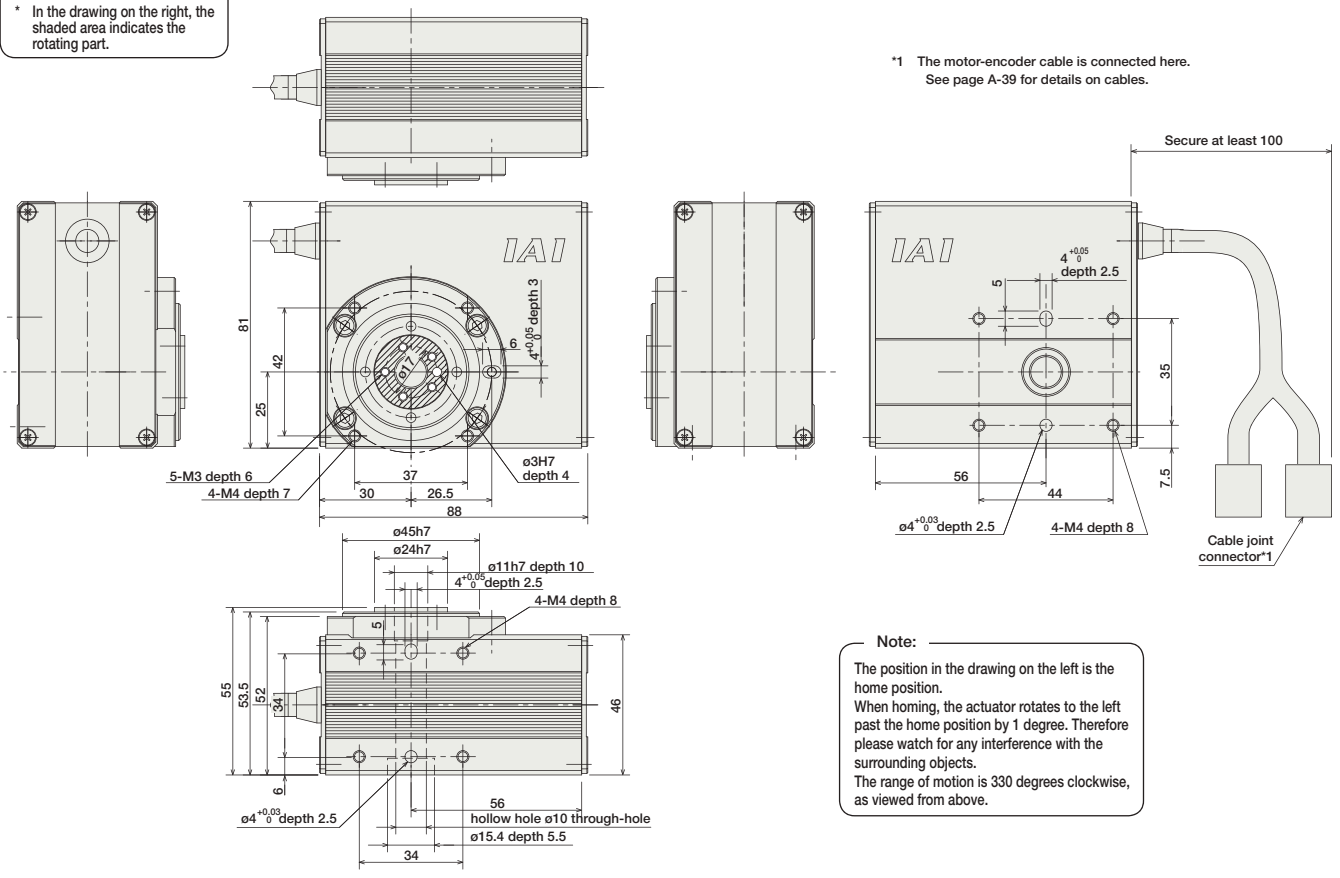

* The bend radius R of the cable is the same as other models.

Weight (kg) 0.92

Compatible Controllers

The RCP2 series actuators can operate with the controllers below. Select the controller according to your usage.

Name	External View	Model	Description	Max. Positioning Points	Input Voltage	Power Supply Capacity	See Page
Solenoid Valve Type		PMEC-C-28PI-NP-2-2	Easy-to-use controller, even for beginners	3 points	AC115V AC230V	See P481	→ P477
	Splash-Proof Solenoid Valve Type		PSEP-C-28PI-NP-2-0				
Positioner Type			PCON-C-28PI-NP-2-0	Positioning is possible for up to 512 points	512 points	DC24V	2A max.
	PCON-CG-28PI-NP-2-0						
Pulse Train Input Type (Differential Line Driver)		PCON-PL-28PI-NP-2-0	Pulse train input type with differential line driver support	(-)	DC24V	2A max.	→ P525
Pulse Train Input Type (Open Collector)		PCON-PO-28PI-NP-2-0	Pulse train input type with open collector support				
Serial Communication Type		PCON-SE-28PI-N-0-0	Dedicated to serial communication	64 points			
Field Network Type		RPCON-28P	Dedicated to field network	768 points			→ P503
Program Control Type		PSEL-C-1-28PI-NP-2-0	Programmed operation is possible. Operation is possible on up to 2 axes	1500 points			→ P557

Note: * When using index mode with multiple rotation type, PMEC/PSEP controller is not available to operate.

* This is for the single-axis PSEL.

- Slider Type
- Mini
- Standard
- Controllers Integrated
- Rod Type
- Mini
- Standard
- Controllers Integrated
- Table/Arm /Flat Type
- Mini
- Standard
- Gripper/ Rotary Type
- Linear Motor Type
- Cleanroom Type
- Splash-Proof
- Controllers
- PMEC /AMEC
- PSEP /ASEP
- ROBO NET
- ERC2
- PCON
- ACON
- SCON
- PSEL
- ASEL
- SSEL
- XSEL
- Pulse Motor
- Servo Motor (24V)
- Servo Motor (230V)
- Linear Motor

RCP2-RTBB/RTBBL

RoboCylinder Rotary Large Vertical Type 76mm Width Pulse Motor

■ Configuration: **RCP2** - [] - **I** - **35P** - [] - [] - [] - [] - []

Series - Type - Encoder - Motor - Deceleration Ratio - Oscillation Angle - Compatible Controllers - Cable Length - Option

RTBB : 330-degree rotation
 RTBBL : Multi-rotational

I: Incremental * The Simple absolute encoder is also considered type "I".

35P : 35 □ size Pulse motor

20: 1/20 deceleration ratio
 30: 1/30 deceleration ratio

330: 330degrees (RTBB only)
 360: 360degrees (RTBBL only)

P1: PCON
 P2: PSEL
 P3: PMEC
 PSEP

N : None
 P : 1m
 S : 3m
 M : 5m
 X □ : Custom
 R □ : Robot cable

NM :Reversed-rotation
 SA: Shaft adapter
 TA : Table adapter

* See page Pre-35 for an explanation of the naming convention.



Technical References P. A-5

- POINT** Notes on Selection
- The output torque decreases as the rotational speed increases. Check the output torque graph on the right to see whether the speed required for your desired motion is supported.
 - The allowable moment of inertia of the rotated work piece varies with the rotational speed. Check the Allowable Moment of Inertia graph on the right to see if the moment of inertia required for your desired motion is within the allowable range.
 - The rated acceleration while moving is 0.3G.
 - When using index mode with multiple rotation type, PMEC/PSEP controller is not available to operate.

■ Speed vs. Load Capacity
 Due to the characteristics of the Pulse Motor, the RCP2 series' load capacity decreases at high speeds. In the table below, check if your desired speed and load capacity are supported.

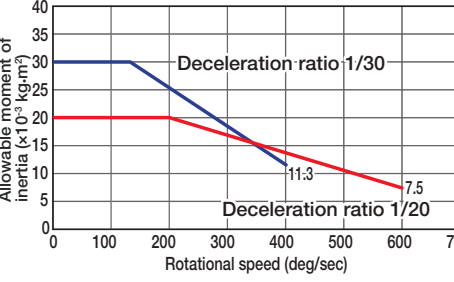
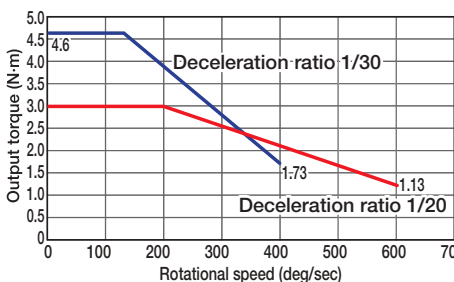

Actuator Specifications					Deceleration Ratio and Max. Speed	
■ Lead and Load Capacity					Stroke	330/360 (deg)
Model	Deceleration Ratio	Max. Torque (N-m)	Allowable Moment of Inertia (kg-m ²)	Oscillation Angle (deg)		
RCP2-RTBB-I-35P-20-330-①-②-③	1/20	3.0	0.02	330	1/20	600
RCP2-RTBB-I-35P-30-330-①-②-③	1/30	4.6	0.03		1/30	400
RCP2-RTBBL-I-35P-20-360-①-②-③	1/20	3.0	0.02	360	(Unit: degrees/s)	
RCP2-RTBBL-I-35P-30-360-①-②-③	1/30	4.6	0.03			

Legend: ① Compatible controller ② Cable length ③ Options

Cable List	
Type	Cable Symbol
Standard Type	P (1m)
	S (3m)
	M (5m)
Special Lengths	X06 (6m) ~ X10 (10m)
	X11 (11m) ~ X15 (15m)
	X16 (16m) ~ X20 (20m)
	X21 (21m) ~ X25 (25m)
Robot Cable	R01 (1m) ~ R03 (3m)
	R04 (4m) ~ R05 (5m)
	R06 (6m) ~ R10 (10m)
	R11 (11m) ~ R15 (15m)
	R16 (16m) ~ R20 (20m)
	R21 (21m) ~ R25 (25m)

* See page A-39 for cables for maintenance.

Actuator Specifications	
Item	Description
Drive System	Hypoid gear
Positioning Repeatability	±0.01 degrees
Homing Accuracy	±0.01 degrees
Lost Motion	±0.1 degrees
Allowable Thrust Load	200N
Allowable Load Moment	17.7N-m
Weight	2.3kg
Ambient Operating Temp./Humidity	0 ~ 40°C, 85% RH or less (non-condensing)

Option List			
Name	Option Code	See Page	
Reversed-rotation	NM	→ A-33	
Shaft adapter	SA	→ A-35	
Table adapter	TA	→ A-37	

Dimensions

CAD drawings can be downloaded from IAI website. www.robocylinder.de



For Special Orders P. A-9

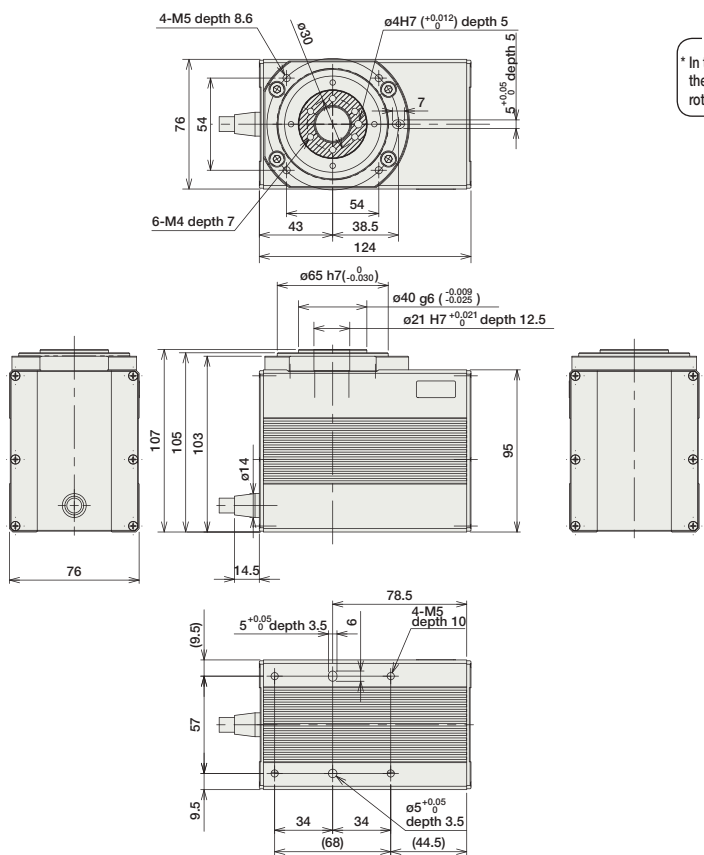

Note:
* In the 2D drawing on the left, the shaded area indicates the rotating part.

*1 The motor-encoder cable is connected here. See page A-39 for details on cables.

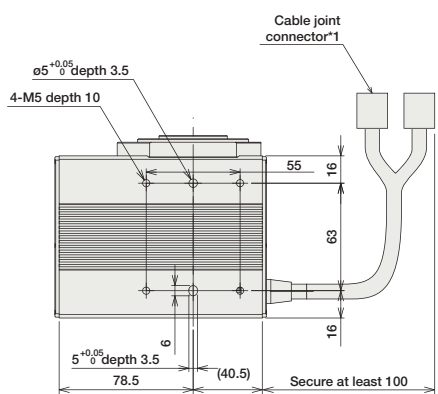

Note:
The position in the 2D drawing on the left is the home position. When homing, the actuator rotates to the left past the home position by 1 degree. Therefore please watch for any interference with the surrounding objects. The range of motion is 330 degrees clockwise, as viewed from above.

Weight (kg) 2.3

Compatible Controllers

The RCP2 series actuators can operate with the controllers below. Select the controller according to your usage.

Name	External View	Model	Description	Max. Positioning Points	Input Voltage	Power Supply Capacity	See Page
Solenoid Valve Type		PMEC-C-35PI-NP-2-2	Easy-to-use controller, even for beginners	3 points	AC115V AC230V	See P481	→ P477
	Splash-Proof Solenoid Valve Type		PSEP-C-35PI-NP-2-0				
Positioner Type			PCON-C-35PI-NP-2-0	Positioning is possible for up to 512 points	512 points		
	PCON-CG-35PI-NP-2-0						
Pulse Train Input Type (Differential Line Driver)		PCON-PL-35PI-NP-2-0	Pulse train input type with differential line driver support	(-)	DC24V	2A max.	→ P525
Pulse Train Input Type (Open Collector)		PCON-PO-35PI-NP-2-0	Pulse train input type with open collector support				
Serial Communication Type		PCON-SE-35PI-N-0-0	Dedicated to serial communication	64 points			
Field Network Type		RPCON-35P	Dedicated to field network	768 points			→ P503
Program Control Type		PSEL-C-1-35PI-NP-2-0	Programmed operation is possible. Operation is possible on up to 2 axes	1500 points			→ P557

Note
* When using index mode with multiple rotation type, PMEC/PSEP controller is not available to operate.

* This is for the single-axis PSEL.

RCP2-RTCB/RTCBL

RoboCylinder Rotary Large Flat Type 124mm Width Pulse Motor

■ Configuration: **RCP2** - [] - **I** - **35P** - [] - [] - [] - [] - []

Series — Type — Encoder — Motor — Deceleration Ratio — Oscillation Angle — Compatible Controllers — Cable Length — Option

RTCB : 330-degree rotation
 RTCBL : Multi-rotational

I: Incremental * The Simple absolute encoder is also considered type "I".

35P : 35 □ size Pulse motor

20: 1/20 deceleration ratio
 30: 1/30 deceleration ratio

330: 330degrees (RTB only)
 360: 360degrees (RTBL only)

P1: PCON
 P2: PCON
 P3: PMEC
 PSEP

N : None
 P : 1m
 S : 3m
 M : 5m
 X □ □ : Custom
 R □ □ : Robot cable

NM : Reversed-rotation
 SA : Shaft adapter
 TA : Table adapter

* See page Pre-35 for an explanation of the naming convention.



Technical References P. A-5



- (1) The output torque decreases as the rotational speed increases. Check the output torque graph on the right to see whether the speed required for your desired motion is supported.
- (2) The allowable moment of inertia of the rotated work piece varies with the rotational speed. Check the Allowable Moment of Inertia graph on the right to see if the moment of inertia required for your desired motion is within the allowable range.
- (3) The rated acceleration while moving is 0.3G.
- (4) When using index mode with multiple rotation type, PMEC/PSEP controller is not available to operate.

Speed vs. Load Capacity

Due to the characteristics of the Pulse motor, the RCP2 series' load capacity decreases at high speeds. In the table below, check if your desired speed and load capacity are supported.

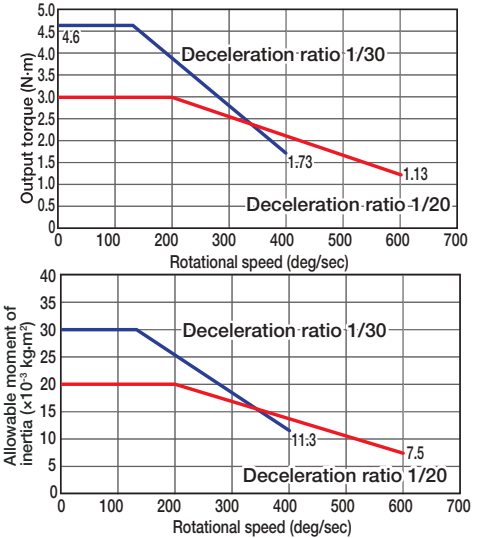

Actuator Specifications

Lead and Load Capacity

Model	Deceleration Ratio	Max. Torque (N·m)	Allowable Moment of Inertia (kg·m ²)	Oscillation Angle (deg)
RCP2-RTCB-I-35P-20-330-①-②-③	1/20	3.0	0.02	330
RCP2-RTCB-I-35P-30-330-①-②-③	1/30	4.6	0.03	
RCP2-RTCBL-I-35P-20-360-①-②-③	1/20	3.0	0.02	360
RCP2-RTCBL-I-35P-30-360-①-②-③	1/30	4.6	0.03	

Legend: ① Compatible controller ② Cable length ③ Options

Deceleration Ratio and Max. Speed

Deceleration Ratio	Stroke 330/360 (deg)
1/20	600
1/30	400

(Unit: degrees/s)

Cable List

Type	Cable Symbol
Standard Type	P (1m)
	S (3m)
	M (5m)
Special Lengths	X06 (6m) ~ X10 (10m)
	X11 (11m) ~ X15 (15m)
	X16 (16m) ~ X20 (20m)
	X21 (21m) ~ X25 (25m)
Robot Cable	R01 (1m) ~ R03 (3m)
	R04 (4m) ~ R05 (5m)
	R06 (6m) ~ R10 (10m)
	R11 (11m) ~ R15 (15m)
	R16 (16m) ~ R20 (20m)
	R21 (21m) ~ R25 (25m)
	R26 (26m) ~ R30 (30m)

* See page A-39 for cables for maintenance.

Actuator Specifications

Item	Description
Drive System	Hypoid gear
Positioning Repeatability	±0.01 degrees
Homing Accuracy	±0.01 degrees
Lost Motion	±0.1 degrees
Allowable Thrust Load	200N
Allowable Load Moment	17.7N·m
Weight	2.2kg
Ambient Operating Temp./Humidity	0 ~ 40°C, 85% RH or less (non-condensing)

Option List

Name	Option Code	See Page
Reversed-rotation	NM	→ A-33
Shaft adapter	SA	→ A-35
Table adapter	TA	→ A-37

Dimensions

CAD drawings can be downloaded from IAI website. www.robocylinder.de



For Special Orders P. A-9

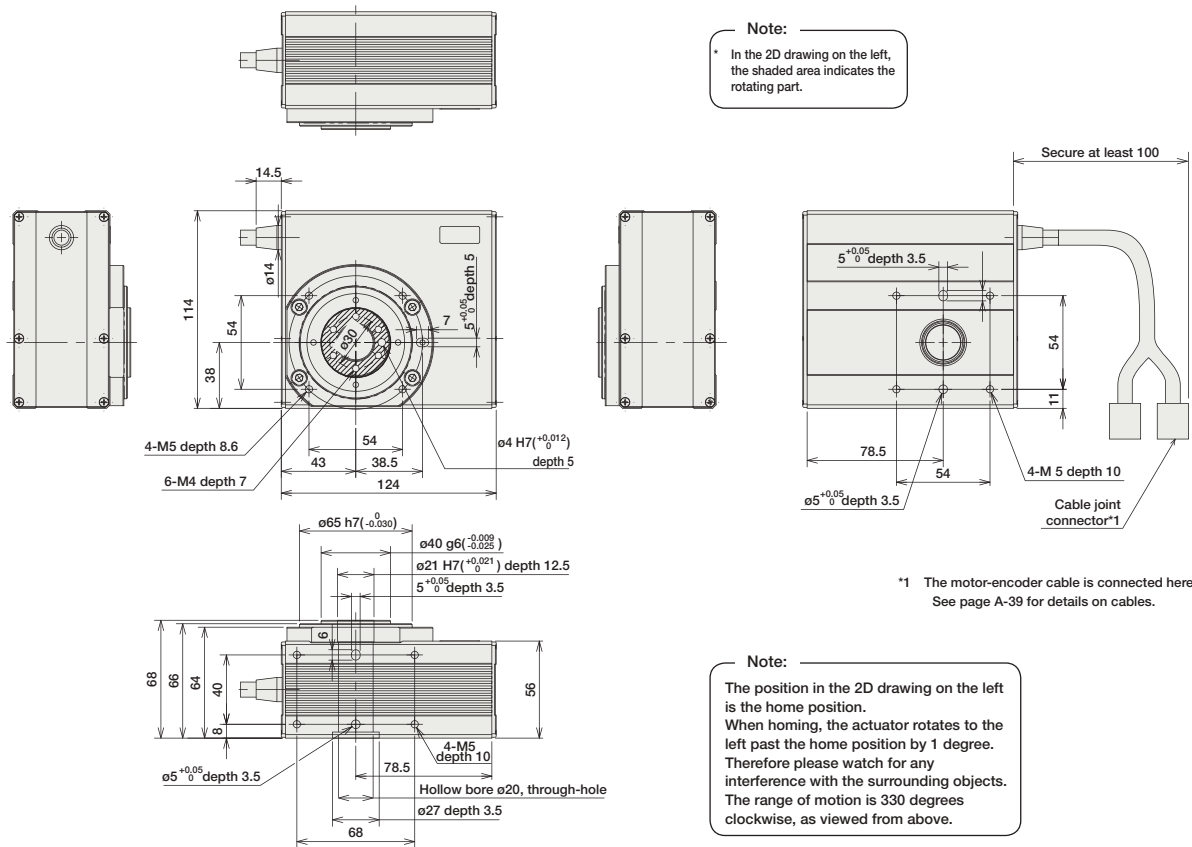

Weight (kg) 2.2

Compatible Controllers

The RCP2 series actuators can operate with the controllers below. Select the controller according to your usage.

Name	External View	Model	Description	Max. Positioning Points	Input Voltage	Power Supply Capacity	See Page
Solenoid Valve Type		PMEC-C-35PI-NP-2-2	Easy-to-use controller, even for beginners	3 points	AC115V AC230V	See P481	→ P477
		PSEP-C-35PI-NP-2-0	Operable with same signal as solenoid valve. Supports both single and double solenoid types. No homing necessary with simple absolute type.				
Splash-Proof Solenoid Valve Type		PSEP-CW-35PI-NP-2-0					
Positioner Type		PCON-C-35PI-NP-2-0	Positioning is possible for up to 512 points	512 points	DC24V	2A max.	→ P525
Safety-Compliant Positioner Type		PCON-CG-35PI-NP-2-0					
Pulse Train Input Type (Differential Line Driver)		PCON-PL-35PI-NP-2-0	Pulse train input type with differential line driver support	(-)	DC24V	2A max.	→ P525
Pulse Train Input Type (Open Collector)		PCON-PO-35PI-NP-2-0	Pulse train input type with open collector support				
Serial Communication Type		PCON-SE-35PI-N-0-0	Dedicated to serial communication	64 points			
Field Network Type		RPCON-35P	Dedicated to field network	768 points			→ P503
Program Control Type		PSEL-C-1-35PI-NP-2-0	Programmed operation is possible Operation is possible on up to 2 axes	1500 points			→ P557

Note
 * When using index mode with multiple rotation type, PMEC/PSEP controller is not available to operate.

* This is for the single-axis PSEL.

- Slider Type
- Mini
- Standard
- Controllers Integrated
- Rod Type
- Mini
- Standard
- Controllers Integrated
- Table/Arm /Flat Type
- Mini
- Standard
- Gripper/ Rotary Type
- Linear Motor Type
- Cleanroom Type
- Splash-Proof
- Controllers
- PMEC /AMEC
- PSEP /ASEP
- ROBO NET
- ERC2
- PCON
- ACON
- SCON
- PSEL
- ASEL
- SSEL
- XSEL
- Pulse Motor
- Servo Motor (24V)
- Servo Motor (230V)
- Linear Motor

RCP2CR-SA5C

Cleanroom RoboCylinder Slider Coupling Type 52mm Width
Pulse motor Aluminum Base

■ Configuration: **RCP2CR-SA5C-I-42P**

Series — Type — Encoder — Motor — Lead — Stroke — Compatible Controllers — Cable Length — Option

I: Incremental
* The simple absolute encoder is also considered type "I".

42P: Pulse motor
42 □ size

20 : 20mm
12 : 12mm
6 : 6mm
3 : 3mm

50: 50mm
800: 800mm (50mm pitch increments)

P1: PCON
RPCON
PSEL
P3: PMEC
PSEP

N : None
P : 1m
S : 3m
M : 5m
X □ □ : Custom
R □ □ : Robot cable

BE: Brake (Cable exiting from end)
BL: Brake (Cable exiting from left)
BR: Brake (Cable exiting from right)
NM: Reversed-home
VR: Intake port on opposite side

* See page Pre-35 for an explanation of the naming convention.



Technical References P. A-5

- POINT**
Notes on Selection
- When the stroke increases, the maximum speed will drop to prevent the ball screw from reaching the critical rotational speed. Use the actuator specification table below to check the maximum speed at the stroke you desire.
 - Since the RCP2 series use the pulse motor, the load capacity decreases at high speeds. In the Speed vs. Load Capacity graph on the right, see if your desired speed and load capacity are supported.
 - The load capacity is based on operation at an acceleration of 0.3G (0.2G for the 3mm-lead model, or when used vertically). The maximum acceleration is 0.7G (0.3G when used vertically), however, note that the load capacity decreases at high accelerations. For more information, see the table of load capacity by acceleration, on page A-53.
 - The ISO cleanliness class 4 is for horizontal usage. Please note that the actuator may not support C10 when used on its side or in vertical orientation.

■ Speed vs. Load Capacity
Due to the characteristics of the Pulse motor, the RCP2 series' load capacity decreases at high speeds. In the table below, check if your desired speed and load capacity are supported.

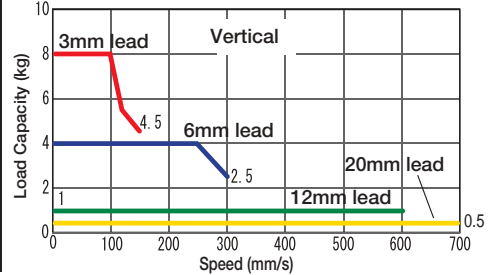
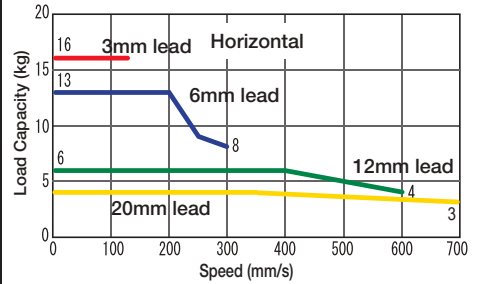

Actuator Specifications

Lead and Load Capacity

(Note 1) Please note that the maximum load capacity decreases as the speed increases.

Model	Lead (mm)	Max. Load Capacity (Note 1)		Stroke (mm)
		Horizontal (kg)	Vertical (kg)	
RCP2CR-SA5C-I-42P-20-①-②-③-④	20	~ 4	0.5	50 ~ 800 (50mm increments)
RCP2CR-SA5C-I-42P-12-①-②-③-④	12	~ 6	1	
RCP2CR-SA5C-I-42P-6-①-②-③-④	6	~ 13	~ 4	
RCP2CR-SA5C-I-42P-3-①-②-③-④	3	16	~ 8	

Legend: ① Stroke ② Compatible controller ③ Cable length ④ Options

Stroke, Max. Speed, and Suction Volume

Stroke / Lead	Stroke (mm)						Suction Volume (N _L /min)
	50 ~ 500 (50mm increments)	600 (mm)	650 (mm)	700 (mm)	750 (mm)	800 (mm)	
20	1000	980	850	740	650	580	80
12	600	540	460	400	360	300	50
6	300	270	230	200	180	150	30
3	150	135	115	100	90	75	15

(Unit: mm/s)

Cable List

Type	Cable Symbol	
Standard Type	P (1m)	
	S (3m)	
	M (5m)	
Special Lengths	X06 (6m) ~ X10 (10m)	
	X11 (11m) ~ X15 (15m)	
	X16 (16m) ~ X20 (20m)	
Robot Cable	R01 (1m) ~ R03 (3m)	
	R04 (4m) ~ R05 (5m)	
	R06 (6m) ~ R10 (10m)	
	R11 (11m) ~ R15 (15m)	
	R16 (16m) ~ R20 (20m)	

* See page A-39 for cables for maintenance.

Option List

Name	Option Code	See Page
Brake (Cable exiting from end)	BE	→ A-25
Brake (Cable exiting from left)	BL	→ A-25
Brake (Cable exiting from right)	BR	→ A-25
Reversed-home	NM	→ A-33
Intake port on opposite side	VR	→ A-38

Actuator Specifications

Item	Description
Drive System	Ball screw ø10mm C10 grade
Positioning Repeatability	±0.02mm
Lost Motion	0.1mm or less
Allowable Static Moment	Ma: 18.6N·m Mb: 26.6N·m Mc: 47.5N·m
Allowable Dynamic Moment (*)	Ma: 4.9N·m Mb: 6.8N·m Mc: 11.7N·m
Overhang Load Length	Ma direction: 150mm or less Mb, Mc direction: 150mm or less
Grease Type	Low dust generation grease (both ball screw and guide)
Cleanliness	ISO class 4 (US FED STD class 10)
Ambient Operating Temp./Humidity	0 ~ 40°C, 85% RH or less (non-condensing)

(*) Based on a 5,000km service life.

Directions of Allowable Load Moments

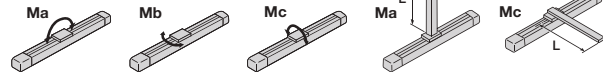

Dimensions

CAD drawings can be downloaded from IAI website. www.robocylinder.de

For Special Orders P. A-9



*For the reversed-home model, the dimensions (distance to home) on the motor-side and that on the opposite side are flipped.

- *1 The motor-encoder cable is connected here. See page A-39 for details on cables.
- *2 When homing, the slider moves to the ME; therefore, please watch for any interference with the surrounding objects.
ME: Mechanical end
SE: Stroke end
The values enclosed in "()" are reference dimensions.
- *3 Reference position for calculating the moment Ma.

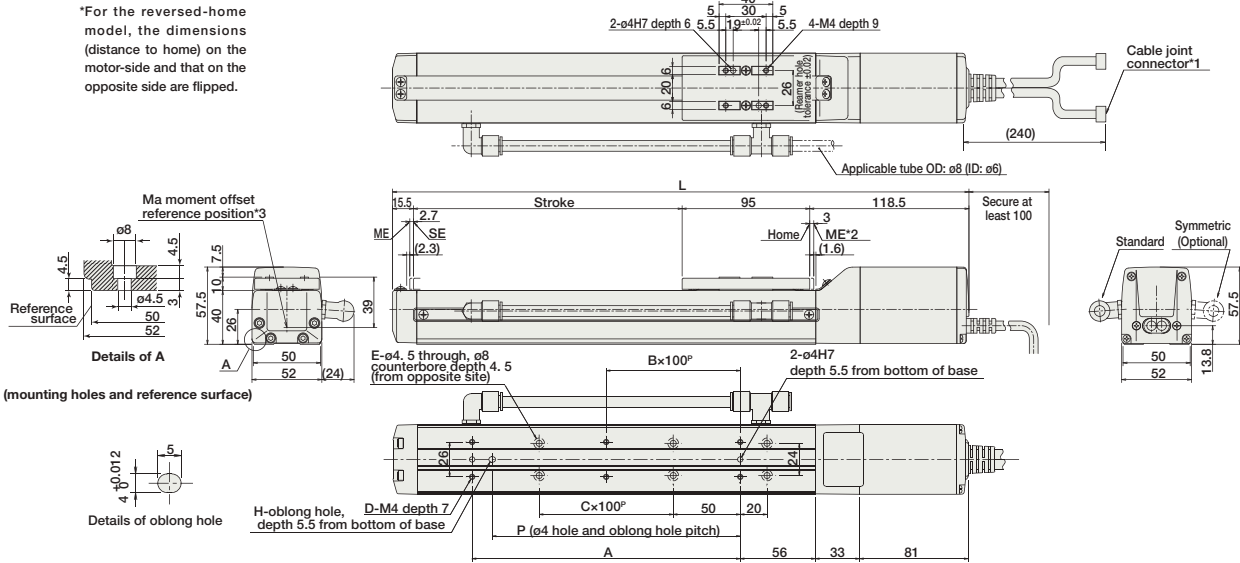

Dimensions of the Brake Section

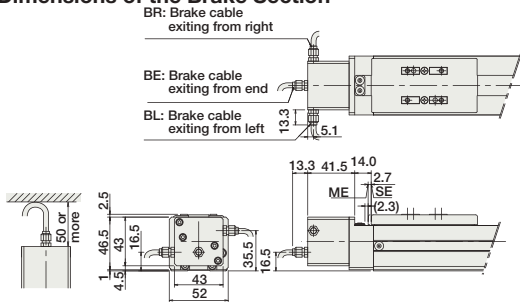

* The length L of a brake-equipped actuator is longer than that of a standard model (see the table) by 40mm (53.3mm with the cable exit out its end); add 0.4kg to weight.

Dimensions and Weight by Stroke

Stroke	50	100	150	200	250	300	350	400	450	500	550	600	650	700	750	800
L	279	329	379	429	479	529	579	629	679	729	779	829	879	929	979	1029
A	73	100	100	200	200	300	300	400	400	500	500	600	600	700	700	800
B	0	0	0	1	1	2	2	3	3	4	4	5	5	6	6	7
C	0	0	1	1	2	2	3	3	4	4	5	5	6	6	7	7
D	4	4	4	6	6	8	8	10	10	12	12	14	14	16	16	18
E	4	4	6	6	8	8	10	10	12	12	14	14	16	16	18	18
H	0	1	1	1	1	1	1	1	1	1	1	1	1	1	1	1
P	0	85	85	185	185	285	285	385	385	485	485	585	585	685	685	785
Weight (kg)	1.7	1.8	1.9	2.0	2.1	2.3	2.4	2.5	2.6	2.7	2.8	3.0	3.1	3.2	3.3	3.4

Compatible Controllers

The RCP2CR series actuators can operate with the controllers below. Select the controller according to your usage.

Name	External View	Model	Description	Max. Positioning Points	Input Voltage	Power Supply Capacity	See Page
Solenoid Valve Type		PMEC-C-42PI-NP-2-2	Easy-to-use controller, even for beginners	3 points	AC115V AC230V	See P481	→ P477
		PSEP-C-42PI-NP-2-0-H	Operable with same signal as solenoid valve. Supports both single and double solenoid types. No homing necessary with simple absolute type.				
Splash-Proof Solenoid Valve Type		PSEP-CW-42PI-NP-2-0-H					
Positioner Type		PCON-C-42PI-NP-2-0-H	Positioning is possible for up to 512 points	512 points	DC24V	2A max.	
Safety-Compliant Positioner Type		PCON-CG-42PI-NP-2-0-H					
Pulse Train Input Type (Differential Line Driver)		PCON-PL-42PI-NP-2-0-H	Pulse train input type with differential line driver support	(-)	DC24V	2A max.	→ P525
Pulse Train Input Type (Open Collector)		PCON-PO-42PI-NP-2-0-H	Pulse train input type with open collector support				
Serial Communication Type		PCON-SE-42PI-N-0-0-H	Dedicated to serial communication	64 points			
Field Network Type		RPCON-42P-H	Dedicated to field network	768 points			→ P503
Program Control Type		PSEL-C-1-42PI-NP-2-0-H	Programmed operation is possible. Operation is possible on up to 2 axes	1500 points			→ P557

* This is for the single-axis PSEL.

- Slider Type
- Mini
- Standard
- Controllers Integrated
- Rod Type
- Mini
- Standard
- Controllers Integrated
- Table/Arm /Flat Type
- Mini
- Standard
- Gripper/ Rotary Type
- Linear Motor Type
- Cleanroom Type
- Splash-Proof
- Controllers
- PMEC /AMEC
- PSEP /ASEP
- ROBO NET
- ERC2
- PCON
- ACON
- SCON
- PSEL
- ASEL
- SSEL
- XSEL
- Pulse Motor
- Servo Motor (24V)
- Servo Motor (230V)
- Linear Motor

RCP2CR-SA6C

Cleanroom RoboCylinder Slider Coupling Type 58mm Width Pulse motor Aluminum Base

■ Configuration: **RCP2CR-SA6C-I-42P**

Series	Type	Encoder	Motor	Lead	Stroke	Compatible Controllers	Cable Length	Option
I: Incremental	42P: Pulse motor	20 : 20mm	50: 50mm	P1: PCON	N: None	BE : Brake (Cable exiting from end)		
* The simple absolute encoder is also considered type "I".	42 □ size	12 : 12mm	50: 50mm	RPCON	P : 1m	BL : Brake (Cable exiting from left)		
		6 : 6mm	800: 800mm	PSEL	S : 3m	BR : Brake (Cable exiting from right)		
		3 : 3mm	(50mm pitch increments)	P3: PMEC	M : 5m	NM : Reversed-home		
				PSEP	X □ □ : Custom	VR : Intake port on opposite side		
					R □ □ : Robot cable			

* See page Pre-35 for an explanation of the naming convention.

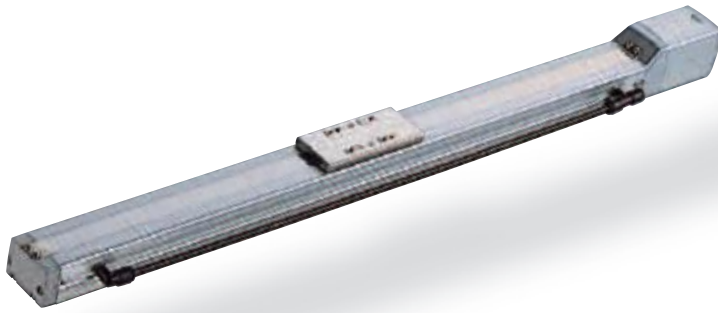

Technical References P. A-5

- POINT** Notes on Selection
- When the stroke increases, the maximum speed will drop to prevent the ball screw from reaching the critical rotational speed. Use the actuator specification table below to check the maximum speed at the stroke you desire.
 - Since the RCP2 series use the pulse motor, the load capacity decreases at high speeds. In the Speed vs. Load Capacity graph on the right, see if your desired speed and load capacity are supported.
 - The load capacity is based on operation at an acceleration of 0.3G (0.2G for the 3mm-lead model, or when used vertically). The maximum acceleration is 0.7G (0.3G when used vertically), however, note that the load capacity decreases at high accelerations. For more information, see the table of load capacity by acceleration, on page A-53.
 - The ISO cleanliness class 4 is for horizontal usage. Please note that the actuator may not support C10 when used on its side or in vertical orientation.

Speed vs. Load Capacity

Due to the characteristics of the Pulse motor, the RCP2 series' load capacity decreases at high speeds. In the table below, check if your desired speed and load capacity are supported.

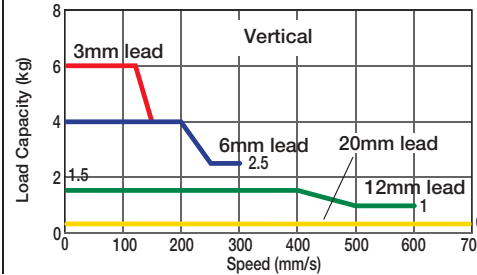
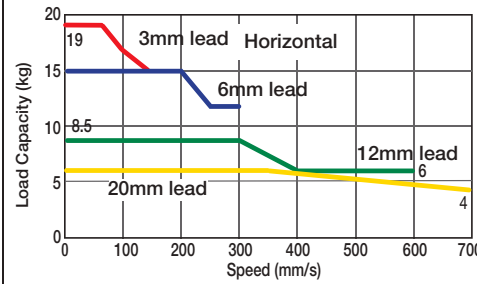

Actuator Specifications

Lead and Load Capacity

(Note 1) Please note that the maximum load capacity decreases as the speed increases.

Model	Lead (mm)	Max. Load Capacity (Note 1)		Stroke (mm)
		Horizontal (kg)	Vertical (kg)	
RCP2CR-SA6C-I-42P-20-①-②-③-④	20	~ 6	0.5	50 ~ 800 (50mm increments)
RCP2CR-SA6C-I-42P-12-①-②-③-④	12	~ 8.5	1.5	
RCP2CR-SA6C-I-42P-6-①-②-③-④	6	~ 15	~ 4	
RCP2CR-SA6C-I-42P-3-①-②-③-④	3	~ 19	~ 6	

Legend: ① Stroke ② Compatible controller ③ Cable length ④ Options

Stroke, Max. Speed, and Suction Volume

Stroke / Lead	Max. Speed (mm/s)						Suction Volume (N _L /min)
	50 ~ 500 (50mm increments)	600 (mm)	650 (mm)	700 (mm)	750 (mm)	800 (mm)	
20	1000	980	850	740	650	580	80
12	600	540	460	400	360	300	50
6	300	270	230	200	180	150	30
3	150	135	115	100	90	75	15

(Unit: mm/s)

③ Cable List

Type	Cable Symbol	
Standard Type	P (1m)	
	S (3m)	
	M (5m)	
Special Lengths	X06 (6m) ~ X10 (10m)	
	X11 (11m) ~ X15 (15m)	
	X16 (16m) ~ X20 (20m)	
Robot Cable	R01 (1m) ~ R03 (3m)	
	R04 (4m) ~ R05 (5m)	
	R06 (6m) ~ R10 (10m)	
	R11 (11m) ~ R15 (15m)	
	R16 (16m) ~ R20 (20m)	

* See page A-39 for cables for maintenance.

④ Option List

Name	Option Code	See Page
Brake (Cable exiting from end)	BE	→ A-25
Brake (Cable exiting from left)	BL	→ A-25
Brake (Cable exiting from right)	BR	→ A-25
Reversed-home	NM	→ A-33
Intake port on opposite side	VR	→ A-38

Actuator Specifications

Item	Description
Drive System	Ball screw φ10mm C10 grade
Positioning Repeatability	±0.02mm
Lost Motion	0.1mm or less
Allowable Static Moment	Ma: 38.3N·m Mb: 54.7N·m Mc: 81.0N·m
Allowable Dynamic Moment (*)	Ma: 8.9N·m Mb: 12.7N·m Mc: 18.6N·m
Overhang Load Length	Ma direction: 220mm or less Mb, Mc direction: 220mm or less
Grease Type	Low dust generation grease (both ball screw and guide)
Cleanliness	ISO class 4 (US FED STD class 10)
Ambient Operating Temp./Humidity	0~40°C, 85% RH or less (non-condensing)

(*) Based on a 5,000km service life.

Directions of Allowable Load Moments

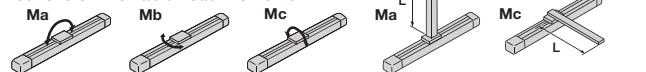

Dimensions

CAD drawings can be downloaded from IAI website. www.robocylinder.de



*For the reversed-home model, the dimensions (distance to home) on the motor-side and that on the opposite side are flipped.

- *1 The motor-encoder cable is connected here. See page A-39 for details on cables.
- *2 When homing, the slider moves to the ME; therefore, please watch for any interference with the surrounding objects.
ME: Mechanical end
SE: Stroke end
The values enclosed in "() " are reference dimensions.
- *3 Reference position for calculating the moment M_a .

For Special Orders P. A-9

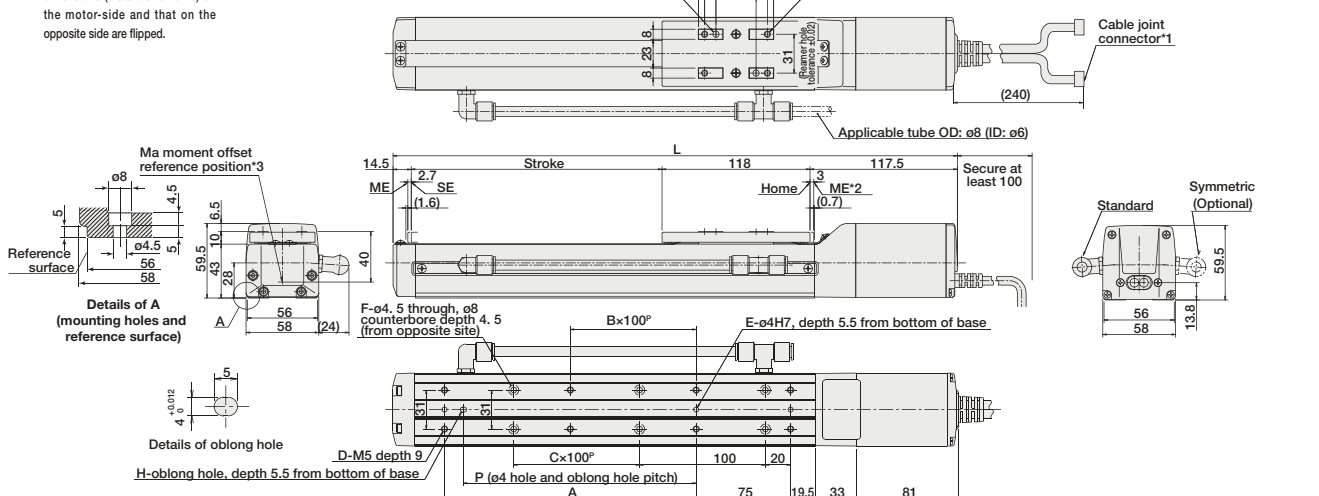

Dimensions of the Brake Section

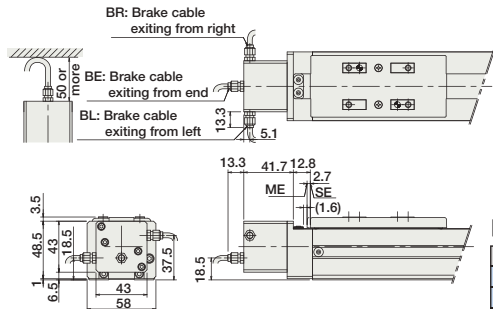

* The length L of a brake-equipped actuator is longer than that of a standard model (see the table) by 40mm (53.3mm with the cable exit out its end); add 0.4kg to weight.

Dimensions and Weight by Stroke

Stroke	50	100	150	200	250	300	350	400	450	500	550	600	650	700	750	800
L	300	350	400	450	500	550	600	650	700	750	800	850	900	950	1000	1050
A	0	100	100	200	200	300	300	400	400	500	500	600	600	700	700	800
B	0	0	0	1	1	2	2	3	3	4	4	5	5	6	6	7
C	0	0	1	1	2	2	3	3	4	4	5	5	6	6	7	7
D	4	6	6	8	8	10	10	12	12	14	14	16	16	18	18	20
E	2	3	3	3	3	3	3	3	3	3	3	3	3	3	3	3
F	4	4	6	6	8	8	10	10	12	12	14	14	16	16	18	18
H	0	1	1	1	1	1	1	1	1	1	1	1	1	1	1	1
P	0	85	85	185	185	285	285	385	385	485	485	585	585	685	685	785
Weight (kg)	2.0	2.2	2.3	2.4	2.6	2.7	2.9	3.0	3.1	3.3	3.4	3.6	3.7	3.8	4.0	4.1

Compatible Controllers

The RCP2CR series actuators can operate with the controllers below. Select the controller according to your usage.

Name	External View	Model	Description	Max. Positioning Points	Input Voltage	Power Supply Capacity	See Page
Solenoid Valve Type		PMEC-C-42PI-NP-2-2	Easy-to-use controller, even for beginners	3 points	AC115V AC230V	See P481	→ P477
		PSEP-C-42PI-NP-2-0-H	Operable with same signal as solenoid valve. Supports both single and double solenoid types. No homing necessary with simple absolute type.				→ P487
Splash-Proof Solenoid Valve Type		PSEP-CW-42PI-NP-2-0-H					
Positioner Type		PCON-C-42PI-NP-2-0-H	Positioning is possible for up to 512 points	512 points	DC24V	2A max.	
Safety-Compliant Positioner Type		PCON-CG-42PI-NP-2-0-H					
Pulse Train Input Type (Differential Line Driver)		PCON-PL-42PI-NP-2-0-H	Pulse train input type with differential line driver support	(-)	DC24V	2A max.	→ P525
Pulse Train Input Type (Open Collector)		PCON-PO-42PI-NP-2-0-H	Pulse train input type with open collector support				
Serial Communication Type		PCON-SE-42PI-N-0-0-H	Dedicated to serial communication	64 points			
Field Network Type		RPCON-42P-H	Dedicated to field network	768 points			→ P503
Program Control Type		PSEL-C-1-42PI-NP-2-0-H	Programmed operation is possible. Operation is possible on up to 2 axes	1500 points			→ P557

* This is for the single-axis PSEL.

- Slider Type
- Mini
- Standard
- Controllers Integrated
- Rod Type
- Mini
- Standard
- Controllers Integrated
- Table/Arm /Flat Type
- Mini
- Standard
- Gripper/ Rotary Type
- Linear Motor Type
- Cleanroom Type
- Splash-Proof
- Controllers
- PMEC /AMEC
- PSEP /ASEP
- ROBO NET
- ERC2
- PCON
- ACON
- SCON
- PSEL
- ASEL
- SSEL
- XSEL
- Pulse Motor
- Servo Motor (24V)
- Servo Motor (230V)
- Linear Motor

RCP2CR-SA7C

Cleanroom RoboCylinder Slider Coupling Type 73mm Width Pulse motor Aluminum Base

■ Configuration: **RCP2CR-SA7C-I-56P**

Series	Type	Encoder	Motor	Lead	Stroke	Compatible Controllers	Cable Length	Option
I: Incremental	56P: Pulse motor	16: 16mm	50: 50mm	P1: PCON	N: None	BE : Brake (Cable exiting from end)		
* The simple absolute encoder is also considered type "I".	56 □ size	8: 8mm	800: 800mm (50mm pitch increments)	RPCON	P: 1m	BL : Brake (Cable exiting from left)		
		4: 4mm		PSEL	S: 3m	BR : Brake (Cable exiting from right)		
				P3: PMEC	M: 5m	NM : Reversed-home		
				PSEP	X □ □ : Custom			
					R □ □ : Robot cable			

* See page Pre-35 for an explanation of the naming convention.

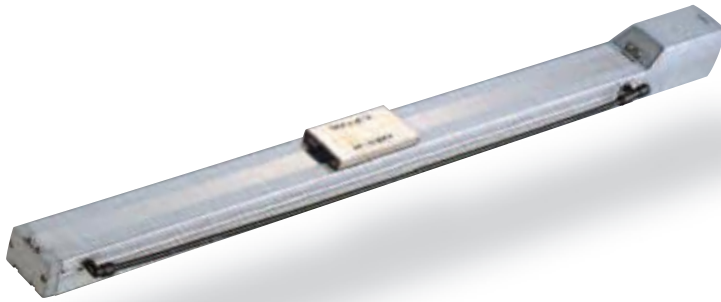

Technical References P. A-5

- POINT** Notes on Selection
- When the stroke increases, the maximum speed will drop to prevent the ball screw from reaching the critical rotational speed. Use the actuator specification table below to check the maximum speed at the stroke you desire.
 - Since the RCP2 series use the pulse motor, the load capacity decreases at high speeds. In the Speed vs. Load Capacity graph on the right, see if your desired speed and load capacity are supported.
 - The load capacity is based on operation at an acceleration of 0.3G (0.2G for the 4mm-lead model, or when used vertically). This is the upper limit of the acceleration.
 - The ISO cleanliness class 4 is for horizontal usage. Please note that the actuator may not support C10 when used on its side or in vertical orientation.

■ Speed vs. Load Capacity
Due to the characteristics of the Pulse motor, the RCP2 series' load capacity decreases at high speeds. In the table below, check if your desired speed and load capacity are supported.

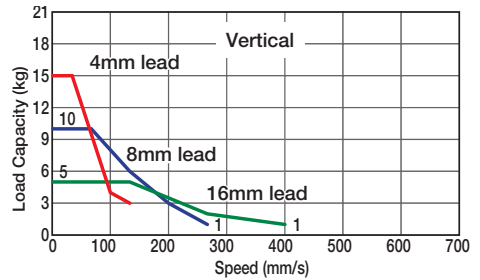
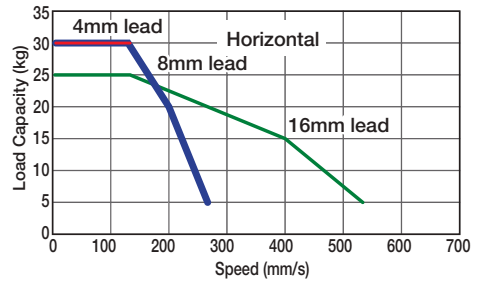

Actuator Specifications

Lead and Load Capacity

(Note 1) Please note that the maximum load capacity decreases as the speed increases.

Model	Lead (mm)	Max. Load Capacity (Note 1)		Stroke (mm)
		Horizontal (kg)	Vertical (kg)	
RCP2CR-SA7C-I-56P-16-①-②-③-④	16	~ 25	~ 5	50~800 (50mm increments)
RCP2CR-SA7C-I-56P-8-①-②-③-④	8	~ 30	~ 10	
RCP2CR-SA7C-I-56P-4-①-②-③-④	4	~ 30	~ 15	

Legend: ① Stroke ② Compatible controller ③ Cable length ④ Options

Stroke, Max. Speed, and Suction Volume

Stroke / Lead	50 ~ 700 (50mm increments)	~ 800 (mm)	Suction Volume (Nl/min)
16	533 <400>	480 <400>	70
8	266	240	40
4	133	120	30

* The values enclosed in "<" apply to vertical usage (Unit: mm/s)

Cable List

Type	Cable Symbol
Standard Type	P (1m)
	S (3m)
	M (5m)
Special Lengths	X06 (6m) ~ X10 (10m)
	X11 (11m) ~ X15 (15m)
	X16 (16m) ~ X20 (20m)
Robot Cable	R01 (1m) ~ R03 (3m)
	R04 (4m) ~ R05 (5m)
	R06 (6m) ~ R10 (10m)
	R11 (11m) ~ R15 (15m)
	R16 (16m) ~ R20 (20m)

* See page A-39 for cables for maintenance.

Option List

Name	Option Code	See Page
Brake (Cable exiting from end)	BE	→ A-25
Brake (Cable exiting from left)	BL	→ A-25
Brake (Cable exiting from right)	BR	→ A-25
Reversed-home	NM	→ A-33
Intake port on opposite side	VR	→ A-38

Actuator Specifications

Item	Description
Drive System	Ball screw ø12mm C10 grade
Positioning Repeatability	±0.02mm
Lost Motion	0.1mm or less
Allowable Static Moment	Ma: 50.4N·m Mb: 71.9N·m Mc: 138.0N·m
Allowable Dynamic Moment (*)	Ma: 13.9N·m Mb: 19.9N·m Mc: 38.3N·m
Overhang Load Length	Ma direction: 230mm or less Mb, Mc direction: 230mm or less
Grease Type	Low dust generation grease (both ball screw and guide)
Cleanliness	ISO class 4 (US FED STD class 10)
Ambient Operating Temp./Humidity	0~40°C, 85% RH or less (non-condensing)

(*) Based on a 5,000km service life.

Directions of Allowable Load Moments

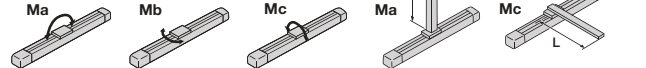

RCP2CR-SS7C Cleanroom RoboCylinder Slider Coupling Type 60mm Width Pulse motor Steel Base

■ Configuration: **RCP2CR-SS7C-I-42P** - [] - [] - [] - [] - []

Series — Type — Encoder — Motor — Lead — Stroke — Compatible Controllers — Cable Length — Option

I: Incremental
* The simple absolute encoder is also considered type "I".

42P: Pulse motor
42 □ size

12: 12mm
6: 6mm
3: 3mm

50: 50mm
600: 600mm (50mm pitch increments)

P1: PCON
RCON
PSEL
P3: PMEC
PSEP

N: None
P: 1m
S: 3m
M: 5m
X □ □ : Custom
R □ □ : Robot cable

B : Brake
NM : Reversed-home
VR : Intake port on opposite side

* See page Pre-35 for an explanation of the naming convention.

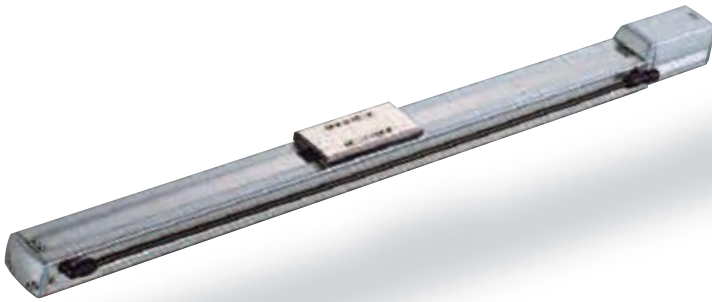

Technical References P. A-5

- POINT** Notes on Selection
- When the stroke increases, the maximum speed will drop to prevent the ball screw from reaching the critical rotational speed. Use the actuator specification table below to check the maximum speed at the stroke you desire.
 - Since the RCP2 series use the pulse motor, the load capacity decreases at high speeds. In the Speed vs. Load Capacity graph on the right, see if your desired speed and load capacity are supported.
 - The load capacity is based on operation at an acceleration of 0.3G (0.2G for the 3mm-lead model, or when used vertically). This is the upper limit of the acceleration.

■ Speed vs. Load Capacity
Due to the characteristics of the Pulse motor, the RCP2 series' load capacity decreases at high speeds. In the table below, check if your desired speed and load capacity are supported.

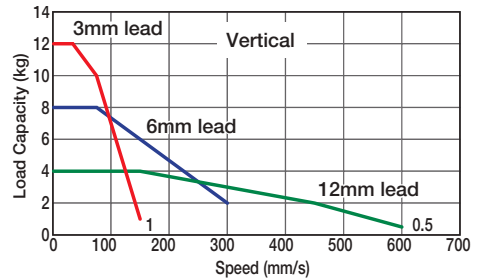
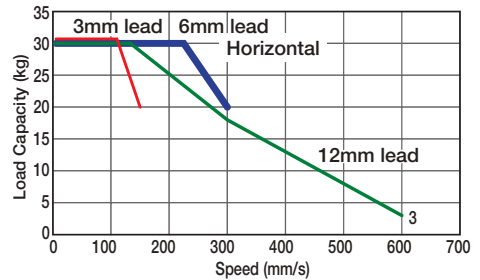

Actuator Specifications

Lead and Load Capacity

(Note 1) Please note that the maximum load capacity decreases as the speed increases.

Model	Lead (mm)	Max. Load Capacity (Note 1)		Stroke (mm)
		Horizontal (kg)	Vertical (kg)	
RCP2CR-SS7C-I-42P-12-①-②-③-④	12	~ 30	~ 4	50~600 (50mm increments)
RCP2CR-SS7C-I-42P-6-①-②-③-④	6	~ 30	~ 8	
RCP2CR-SS7C-I-42P-3-①-②-③-④	3	~ 30	~ 12	

Legend: ① Stroke ② Compatible controller ③ Cable length ④ Options

Stroke, Max. Speed, and Suction Volume

Stroke Lead	50 ~ 500 (50mm increments)	~ 600 (mm)	Suction Volume (Nl/min)
12	600	470	50
6	300	230	30
3	150	115	15

(Unit: mm/s)

Cable List

Type	Cable Symbol
Standard Type	P (1m)
	S (3m)
	M (5m)
Special Lengths	X06 (6m) ~ X10 (10m)
	X11 (11m) ~ X15 (15m)
	X16 (16m) ~ X20 (20m)
Robot Cable	R01 (1m) ~ R03 (3m)
	R04 (4m) ~ R05 (5m)
	R06 (6m) ~ R10 (10m)
	R11 (11m) ~ R15 (15m)
	R16 (16m) ~ R20 (20m)

* See page A-39 for cables for maintenance.

Option List

Name	Option Code	See Page
Brake	B	→ A-25
Reversed-home	NM	→ A-33
Intake port on opposite side	VR	→ A-38

Actuator Specifications

Item	Description
Drive System	Ball screw ø10mm C10 grade
Positioning Repeatability	±0.02mm
Lost Motion	0.1mm or less
Allowable Static Moment	Ma: 79.4N·m Mb: 79.4N·m Mc: 172.9N·m
Allowable Dynamic Moment (*)	Ma: 14.7N·m Mb: 14.7N·m Mc: 33.3N·m
Overhang Load Length	Ma direction: 300mm or less Mb, Mc direction: 300mm or less
Grease Type	Low dust generation grease (both ball screw and guide)
Cleanliness	ISO class 4 (US FED STD class 10)
Ambient Operating Temp./Humidity	0~40°C, 85% RH or less (non-condensing)

(*) Based on a 10,000km service life.

Directions of Allowable Load Moments

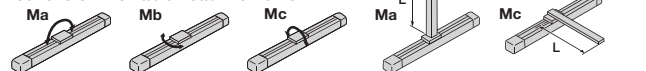

Dimensions

CAD drawings can be downloaded from IAI website. www.robocylinder.de



*For the reversed-home model, the dimensions (distance to home) on the motor-side and that on the opposite side are flipped.

- *1 The motor-encoder cable is connected here. See page A-39 for details on cables.
- *2 When homing, the slider moves to the ME; therefore, please watch for any interference with the surrounding objects.
ME: Mechanical end
SE: Stroke end
The dimensions enclosed in "()" are reference dimensions.
- *3 Reference position for calculating the moment Ma.

For Special Orders P. A-9

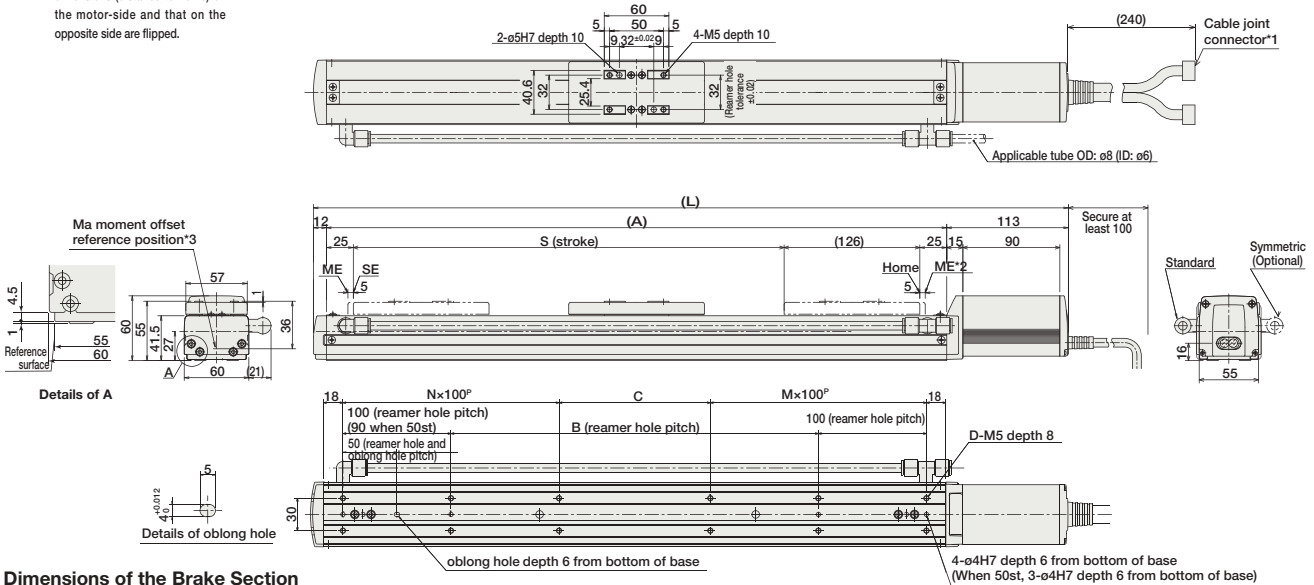

Dimensions of the Brake Section

* The length L of a brake-equipped actuator is longer than that of a standard model (see the table) by 24.5mm; add 0.3kg to weight.

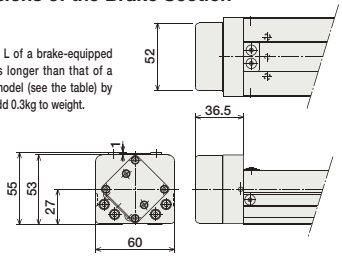

■ Dimensions and Weight by Stroke

Stroke	50	100	150	200	250	300	350	400	450	500	550	600
L	351	401	451	501	551	601	651	701	751	801	851	901
A	226	276	326	376	426	476	526	576	626	676	726	776
B	0	40	90	140	190	240	290	340	390	440	490	540
C	90	40	90	140	190	240	290	340	390	440	490	540
D	6	8	8	8	8	12	12	12	12	16	16	16
M	1	1	1	1	1	2	2	2	2	3	3	3
N	0	1	1	1	1	2	2	2	2	3	3	3
Weight (kg)	3.3	3.6	3.9	4.2	4.6	4.9	5.3	5.6	6.0	6.3	6.6	6.9

Compatible Controllers

The RCP2CR series actuators can operate with the controllers below. Select the controller according to your usage.

Name	External View	Model	Description	Max. Positioning Points	Input Voltage	Power Supply Capacity	See Page
Solenoid Valve Type		PMEC-C-42PI-NP-2-2	Easy-to-use controller, even for beginners	3 points	AC115V AC230V	See P481	→ P477
		PSEP-C-42PI-NP-2-0	Operable with same signal as solenoid valve. Supports both single and double solenoid types. No homing necessary with simple absolute type.				→ P487
Splash-Proof Solenoid Valve Type		PSEP-CW-42PI-NP-2-0					
Positioner Type		PCON-C-42PI-NP-2-0	Positioning is possible for up to 512 points	512 points	DC24V	2A max.	
Safety-Compliant Positioner Type		PCON-CG-42PI-NP-2-0					
Pulse Train Input Type (Differential Line Driver)		PCON-PL-42PI-NP-2-0	Pulse train input type with differential line driver support	(-)	DC24V	2A max.	→ P525
Pulse Train Input Type (Open Collector)		PCON-PO-42PI-NP-2-0	Pulse train input type with open collector support				
Serial Communication Type		PCON-SE-42PI-N-0-0	Dedicated to serial communication	64 points			
Field Network Type		RPCON-42P	Dedicated to field network	768 points			→ P503
Program Control Type		PSEL-C-1-42PI-NP-2-0	Programmed operation is possible. Operation is possible on up to 2 axes	1500 points			→ P557

* This is for the single-axis PSEL.

- Slider Type
- Mini
- Standard
- Controllers Integrated
- Rod Type
- Mini
- Standard
- Controllers Integrated
- Table/Arm /Flat Type
- Mini
- Standard
- Gripper/ Rotary Type
- Linear Motor Type
- Cleanroom Type
- Splash-Proof
- Controllers
- PMEC /AMEC
- PSEP /ASEP
- ROBO NET
- ERC2
- PCON
- ACON
- SCON
- PSEL
- ASEL
- SSEL
- XSEL
- Pulse Motor
- Servo Motor (24V)
- Servo Motor (230V)
- Linear Motor

RCP2CR-SS8C Cleanroom RoboCylinder Slider Coupling Type 80mm Width Pulse motor Steel Base

■ Configuration: **RCP2CR-SS8C-I-56P** - [] - [] - [] - [] - []

Series — Type — Encoder — Motor — Lead — Stroke — Compatible Controllers — Cable Length — Option

I: Incremental
* The simple absolute encoder is also considered type "I".

56P: Pulse motor
56 □ size

20: 20mm
10: 10mm
5: 5mm

50: 50mm
1000: 1000mm (50mm pitch increments)

P1: PCON
RCON
PSEL
P3: PMEC
PSEP

N: None
P: 1m
S: 3m
M: 5m
X □ □ : Custom
R □ □ : Robot cable

B : Brake
NM : Reversed-home
VR : Intake port on opposite side

* See page Pre-35 for an explanation of the naming convention.

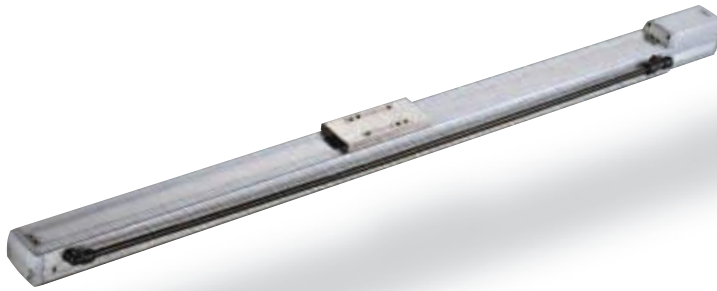

Technical References P. A-5

- POINT** Notes on Selection
- When the stroke increases, the maximum speed will drop to prevent the ball screw from reaching the critical rotational speed. Use the actuator specification table below to check the maximum speed at the stroke you desire.
 - Since the RCP2 series use the pulse motor, the load capacity decreases at high speeds. In the Speed vs. Load Capacity graph on the right, see if your desired speed and load capacity are supported.
 - The load capacity is based on operation at an acceleration of 0.3G (0.2G for the 5mm-lead model, or when used vertically). This is the upper limit of the acceleration.

■ Speed vs. Load Capacity
Due to the characteristics of the Pulse motor, the RCP2 series' load capacity decreases at high speeds. In the table below, check if your desired speed and load capacity are supported.

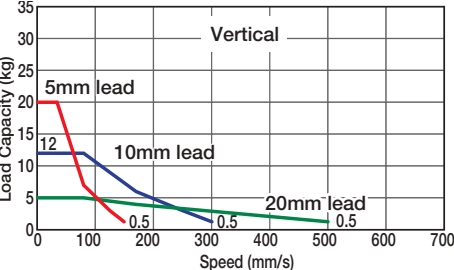
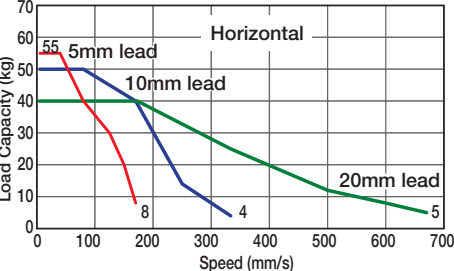

Actuator Specifications

■ Lead and Load Capacity (Note 1) Please note that the maximum load capacity decreases as the speed increases.

Model	Lead (mm)	Max. Load Capacity (Note 1)		Stroke (mm)
		Horizontal (kg)	Vertical (kg)	
RCP2CR-SS8C-I-56P-20-①-②-③-④	20	~ 40	~ 5	50~1000 (50mm increments)
RCP2CR-SS8C-I-56P-10-①-②-③-④	10	~ 50	~ 12	
RCP2CR-SS8C-I-56P-5-①-②-③-④	5	~ 55	~ 20	

Legend: ① Stroke ② Compatible controller ③ Cable length ④ Options

■ Stroke, Max. Speed, and Suction Volume

Stroke / Lead	50 ~ 800 (50mm increments)	~ 900 (mm)	~ 1000 (mm)	Suction Volume (NL/min)
20	666 <500>	625 <500>	515 <500>	80
10	333 <300>	310 <300>	255	40
5	165 <150>	155 <150>	125	20

* The values enclosed in "<" apply to vertical usage (Unit: mm/s)

Cable List

Type	Cable Symbol
Standard Type	P (1m)
	S (3m)
	M (5m)
Special Lengths	X06 (6m) ~ X10 (10m)
	X11 (11m) ~ X15 (15m)
	X16 (16m) ~ X20 (20m)
Robot Cable	R01 (1m) ~ R03 (3m)
	R04 (4m) ~ R05 (5m)
	R06 (6m) ~ R10 (10m)
	R11 (11m) ~ R15 (15m)
	R16 (16m) ~ R20 (20m)

* See page A-39 for cables for maintenance.

Option List

Name	Option Code	See Page
Brake	B	→ A-25
Reversed-home	NM	→ A-33
Intake port on opposite side	VR	→ A-38

Actuator Specifications

Item	Description
Drive System	Ball screw ø16mm C10 grade
Positioning Repeatability	±0.02mm
Lost Motion	0.1mm or less
Allowable Static Moment	Ma: 198.9N·m Mb: 198.9N·m Mc: 416.7N·m
Allowable Dynamic Moment (*)	Ma: 36.3N·m Mb: 36.3N·m Mc: 77.4N·m
Overhang Load Length	Ma direction: 450mm or less Mb, Mc direction: 450mm or less
Grease Type	Low dust generation grease (both ball screw and guide)
Cleanliness	ISO class 4 (US FED STD class 10)
Ambient Operating Temp./Humidity	0~40°C, 85% RH or less (non-condensing)

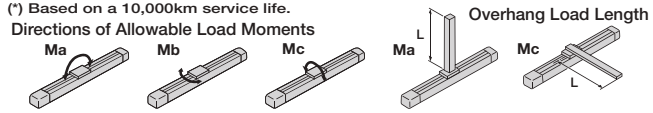

Dimensions

CAD drawings can be downloaded from IAI website. www.robocylinder.de

For Special Orders P. A-9



*For the reversed-home model, the dimensions (distance to home) on the motor-side and that on the opposite side are flipped.

- *1 The motor-encoder cable is connected here. See page A-39 for details on cables.
- *2 When homing, the slider moves to the ME; therefore, please watch for any interference with the surrounding objects.
ME: Mechanical end
SE: Stroke end
- *3 Reference position for calculating the moment Ma.

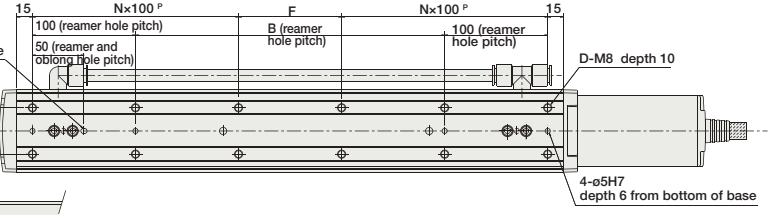
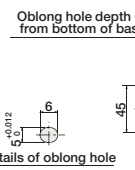
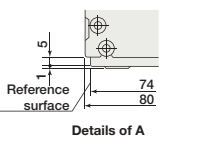
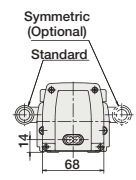
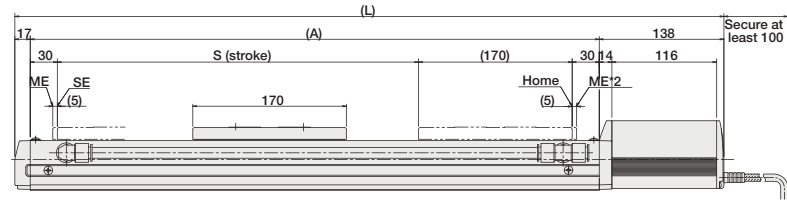
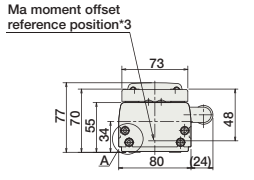
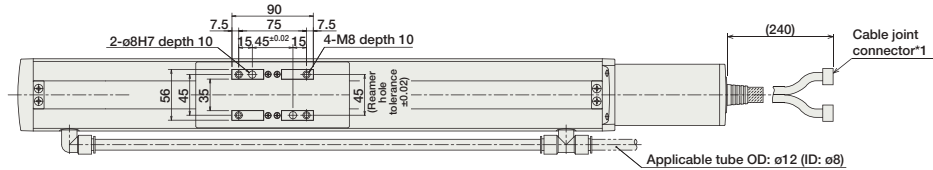

Dimensions of the Brake Section

* The length L of a brake-equipped actuator is longer than that of a standard model (see the table) by 26mm; add 0.5kg to weight.

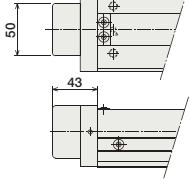
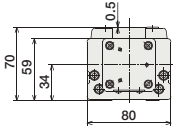

Dimensions and Weight by Stroke

Stroke	50	100	150	200	250	300	350	400	450	500	550	600	650	700	750	800	850	900	950	1000
L	435	485	535	585	635	685	735	785	835	885	935	985	1035	1085	1135	1185	1235	1285	1335	1385
A	280	330	380	430	480	530	580	630	680	730	780	830	880	930	980	1030	1080	1130	1180	1230
B	50	100	150	200	250	300	350	400	450	500	550	600	650	700	750	800	850	900	950	1000
D	8	8	8	10	12	12	12	14	16	16	16	18	20	20	22	24	24	24	24	26
F	50	100	150	0	50	100	150	0	50	100	150	0	50	100	150	0	50	100	150	0
N	1	1	1	2	2	2	3	3	3	3	3	4	4	4	4	5	5	5	5	6
Weight (kg)	7.0	7.5	8.0	8.5	9.0	9.6	10.1	10.6	11.2	11.7	12.3	12.7	13.3	13.8	14.4	14.9	15.4	15.9	16.5	17.0

Compatible Controllers

The RCP2CR series actuators can operate with the controllers below. Select the controller according to your usage.

Name	External View	Model	Description	Max. Positioning Points	Input Voltage	Power Supply Capacity	See Page
Solenoid Valve Type		PMEC-C-56PI-NP-2-2	Easy-to-use controller, even for beginners	3 points	AC115V AC230V	See P481	→ P477
		PSEP-C-56PI-NP-2-0	Operable with same signal as solenoid valve. Supports both single and double solenoid types. No homing necessary with simple absolute type.				
Splash-Proof Solenoid Valve Type		PSEP-CW-56PI-NP-2-0					
Positioner Type		PCON-C-56PI-NP-2-0	Positioning is possible for up to 512 points	512 points	DC24V	2A max.	
Safety-Compliant Positioner Type		PCON-CG-56PI-NP-2-0					
Pulse Train Input Type (Differential Line Driver)		PCON-PL-56PI-NP-2-0	Pulse train input type with differential line driver support	(-)	DC24V	2A max.	→ P525
Pulse Train Input Type (Open Collector)		PCON-PO-56PI-NP-2-0	Pulse train input type with open collector support				
Serial Communication Type		PCON-SE-56PI-NI-0-0	Dedicated to serial communication	64 points			
Field Network Type		RPCON-56P	Dedicated to field network	768 points			→ P503
Program Control Type		PSEL-C-1-56PI-NP-2-0	Programmed operation is possible. Operation is possible on up to 2 axes	1500 points			→ P557

* This is for the single-axis PSEL.

- Slider Type
- Mini
- Standard
- Controllers Integrated
- Rod Type
- Mini
- Standard
- Controllers Integrated
- Table/Arm /Flat Type
- Mini
- Standard
- Gripper/ Rotary Type
- Linear Motor Type
- Cleanroom Type
- Splash-Proof
- Controllers
- PMEC /AMEC
- PSEP /ASEP
- ROBO NET
- ERC2
- PCON
- ACON
- SCON
- PSEL
- ASEL
- SSEL
- XSEL
- Pulse Motor
- Servo Motor (24V)
- Servo Motor (230V)
- Linear Motor

- Slider Type
- Mini
- Standard
- Controllers Integrated
- Rod Type
- Mini
- Standard
- Controllers Integrated
- Table/Arm /Flat Type
- Mini
- Standard
- Gripper/ Rotary Type
- Linear Motor Type
- Cleanroom Type
- Splash-Proof
- Controllers
- PMEC /AMEC
- PSEP /ASEP
- ROBO NET
- ERC2
- PCON
- ACON
- SCON
- PSEL
- ASEL
- SSEL
- XSEL
- Pulse Motor
- Servo Motor (24V)
- Servo Motor (230V)
- Linear Motor

RCP2CR-HS8C Cleanroom RoboCylinder High-Speed Slider Coupling Type 80mm Width Pulse motor Steel Base

■ Configuration: **RCP2CR** - **HS8C** - **I** - **86P** - - - **P2** - -

Series — Type — Encoder — Motor — Lead — Stroke — Compatible Controllers — Cable Length — Option

I: Incremental 86P: Pulse motor 56 □ high output 30: 30mm 50: 50mm } 1000: 1000mm (50mm pitch increments) P2: PCON-CF N: None P: 1m S: 3m M: 5m X □ □ : Custom R □ □ : Robot cable B : Brake NM: Reversed-home VR : Intake port on opposite side

* See page Pre-35 for an explanation of the naming convention.

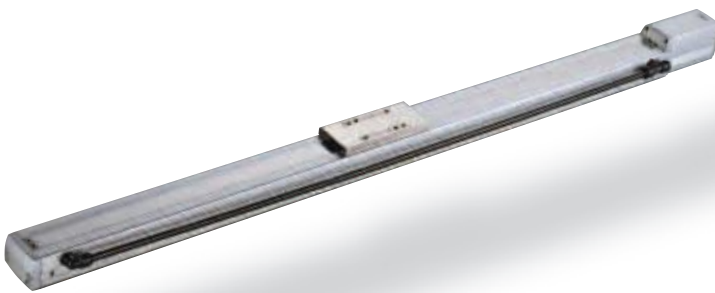

Technical References P. A-5

- Notes on Selection**
- Due to the large lead of the ball screw in high-speed actuators, operating at low speeds may cause vibration and/or noise. Therefore, use the actuator at speeds over 100mm/s.
 - When the stroke increases, the maximum speed will drop to prevent the ball screw from reaching the critical rotational speed. Use the actuator specification table below to check the maximum speed at the stroke you desire.
 - Since the RCP2 series use the pulse motor, the load capacity decreases at high speeds. In the Speed vs. Load Capacity graph on the right, see if your desired speed and load capacity are supported.
 - The load capacity is based on operation at an acceleration of 0.3G (0.2G when used vertically). 0.5G (horizontal) and 0.3G (vertical) are the upper limits of the acceleration.

■ **Speed vs. Load Capacity**
 Due to the characteristics of the Pulse motor, the RCP2 series' load capacity decreases at high speeds. In the table below, check if your desired speed and load capacity are supported.

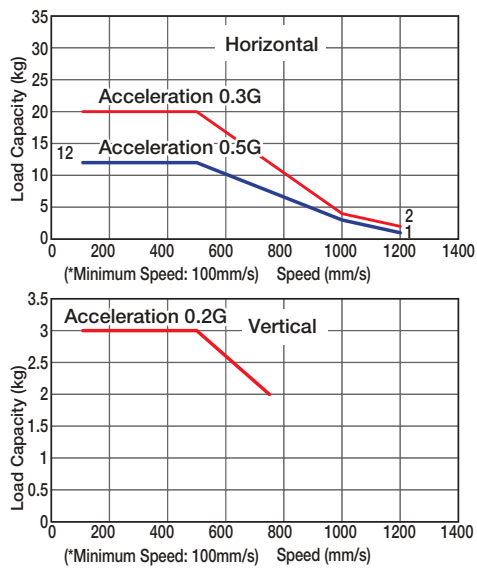

Actuator Specifications				
Model	Lead (mm)	Max. Load Capacity (Note 1)		Stroke (mm)
		Horizontal (kg)	Vertical (kg)	
RCP2CR-HS8C-I-86P-30-①-P2-②-③	30	~ 20	~ 3	50~1000 (50mm increments)

(Note 1) Please note that the maximum load capacity decreases as the speed increases.

Stroke / Lead	Stroke and Maximum Speed			Suction Volume (Nl/min)
	50 ~ 800 (50mm increments)	~ 900 (mm)	~ 1000 (mm)	
30	1200 <750>	1000 <750>	800 <750>	180

* The values enclosed in "< >" apply to vertical usage (Unit: mm/s)

Type	Cable Symbol
Standard Type	P (1m)
	S (3m)
	M (5m)
Special Lengths	X06 (6m) ~ X10 (10m)
	X11 (11m) ~ X15 (15m)
	X16 (16m) ~ X20 (20m)
	X21 (21m) ~ X25 (25m)
Robot Cable	R01 (1m) ~ R03 (3m)
	R04 (4m) ~ R05 (5m)
	R06 (6m) ~ R10 (10m)
	R11 (11m) ~ R15 (15m)
	R16 (16m) ~ R20 (20m)
	R21 (21m) ~ R25 (25m)

* See page A-39 for cables for maintenance.

Name	Option Code	See Page
Brake	B	→ A-25
Reversed-home	NM	→ A-33
Intake port on opposite side	VR	→ A-38

Item	Description
Drive System	Ball screw ø16mm C10 grade
Positioning Repeatability	±0.02mm
Lost Motion	0.1mm or less
Allowable Static Moment	Ma: 198.9N·m Mb: 198.9N·m Mc: 416.7N·m
Allowable Dynamic Moment (*)	Ma: 36.3N·m Mb: 36.3N·m Mc: 77.4N·m
Overhang Load Length	Ma direction: 450mm or less Mb, Mc direction: 450mm or less
Grease Type	Low dust generation grease (both ball screw and guide)
Cleanliness	ISO class 4 (US FED STD class 10)
Ambient Operating Temp./Humidity	0~40°C, 85% RH or less (non-condensing)

(*) Based on a 10,000km service life.

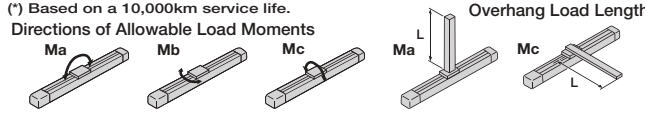

- Slider Type
- Mini
- Standard
- Controllers Integrated
- Rod Type
- Mini
- Standard
- Controllers Integrated
- Table/Arm /Flat Type
- Mini
- Standard
- Gripper/ Rotary Type
- Linear Motor Type
- Cleanroom Type
- Splash-Proof
- Controllers
- PMEC /AMEC
- PSEP /ASEP
- ROBO NET
- ERC2
- PCON
- ACON
- SCON
- PSEL
- ASEL
- SSEL
- XSEL
- Pulse Motor
- Servo Motor (24V)
- Servo Motor (230V)
- Linear Motor

Dimensions

CAD drawings can be downloaded from IAI website. www.robocylinder.de

For Special Orders P. A-9



*For the reversed-home model, the dimensions (distance to home) on the motor-side and that on the opposite side are flipped.

- *1 The motor-encoder cable is connected here. See page A-39 for details on cables.
- *2 When homing, the slider moves to the ME; therefore, please watch for any interference with the surrounding objects.
ME: Mechanical end
SE: Stroke end
- *3 Reference position for calculating the moment Ma.

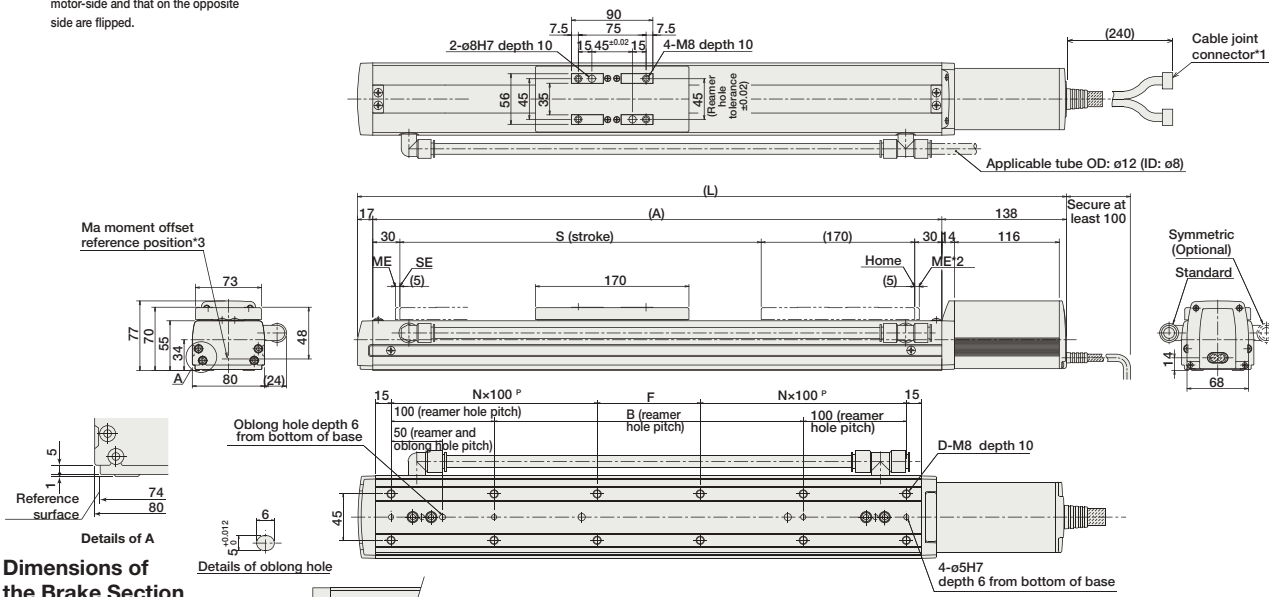

Dimensions of the Brake Section

* The length L of a brake-equipped actuator is longer than that of a standard model (see the table) by 26mm; add 0.5kg to weight.

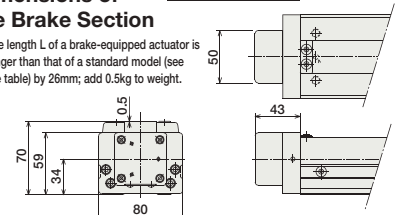

Dimensions and Weight by Stroke

Stroke	50	100	150	200	250	300	350	400	450	500	550	600	650	700	750	800	850	900	950	1000
L	435	485	535	585	635	685	735	785	835	885	935	985	1035	1085	1135	1185	1235	1285	1335	1385
A	280	330	380	430	480	530	580	630	680	730	780	830	880	930	980	1030	1080	1130	1180	1230
B	50	100	150	200	250	300	350	400	450	500	550	600	650	700	750	800	850	900	950	1000
D	8	8	8	10	12	12	12	14	16	16	16	18	20	20	20	22	24	24	24	26
F	50	100	150	0	50	100	150	0	50	100	150	0	50	100	150	0	50	100	150	0
N	1	1	1	2	2	2	3	3	3	4	4	4	4	4	4	5	5	5	5	6
Weight (kg)	7.0	7.5	8.0	8.5	9.0	9.6	10.1	10.6	11.2	11.7	12.3	12.7	13.3	13.8	14.4	14.9	15.4	15.9	16.5	17.0

Compatible Controllers

The RCP2CR-HS8C series actuators can operate with the controllers below.

Name	External View	Model	Description	Max. Positioning Points	Input Voltage	Power Supply Capacity	See Page
Positioner Type		PCON-CF-86PI-NP-2-0	Positioning is possible for up to 512 points	512 points	DC24V	6A max.	→ P525

Note: Please note that a dedicated CF type encoder cable is used, which is different from the encoder cable used for the PCON-C/CG/CY/PL/PO/SE controllers.

- Slider Type
- Mini
- Standard
- Controllers Integrated
- Rod Type
- Mini
- Standard
- Controllers Integrated
- Table/Arm /Flat Type
- Mini
- Standard
- Gripper/ Rotary Type
- Linear Motor Type
- Cleanroom Type
- Splash-Proof
- Controllers
- PMEC /AMEC
- PSEP /ASEP
- ROBO NET
- ERC2
- PCON
- ACON
- SCON
- PSEL
- ASEL
- SSEL
- XSEL
- Pulse Motor
- Servo Motor (24V)
- Servo Motor (230V)
- Linear Motor

RCP2CR-GRSS

Cleanroom RoboCylinder 2-Finger Gripper Mini Slider Type 42mm Width Pulse motor

■ Configuration: **RCP2CR- GRSS - I - 20P - 30 - 8** - - -

Series — Type — Encoder — Motor — Deceleration Ratio — Stroke — Compatible Controllers — Cable Length — Option

I: Incremental
* The simple absolute encoder is also considered type "I".

20P: Pulse motor
20 □ size

30 : 1/30
deceleration ratio

8: 8mm
(4mm per side)

P1: PCON
RPCON
PSEL
P3: PMECP
PSEP

N : None
P : 1m
S : 3m
M : 5m
X □ □ : Custom

NM: Reversed-home
FB: Flange bracket
SB: Shaft bracket

* See page Pre-35 for an explanation of the naming convention.

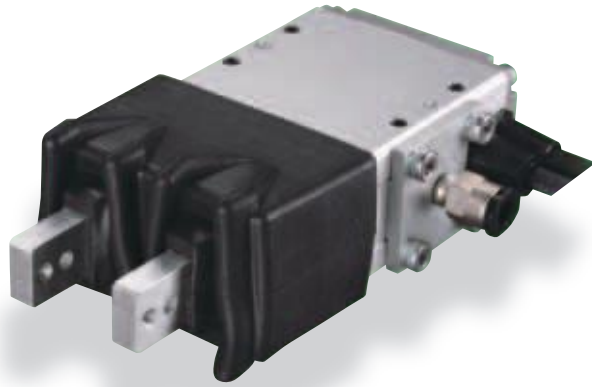

Technical References P. A-5

- POINT**
Notes on Selection
- (1) The maximum opening/closing speed indicates the operating speed on one side. The relative operating speed is twice this value.
 - (2) The maximum gripping force is the sum of the gripping forces of both fingers, at a gripping point distance of 0mm and no overhang distance. The workpiece weight that can be actually moved depends on the friction coefficient between the gripper fingers and the workpiece, as well as on the shape of the workpiece. As a rough guide, a workpiece's weight should not exceed 1/10 to 1/20 of the gripping force. (See page A-74 for details.)
 - (3) The rated acceleration while moving is 0.3G.

■ Gripping Force Adjustment
The gripping (pushing) force can be adjusted freely within the range of current limits of 20% to 70%.

* The gripping forces in the following diagrams indicate the sum of the gripping forces of both fingers.

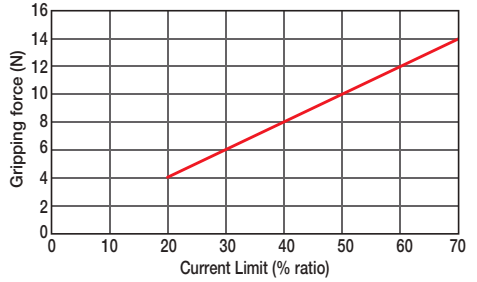

* The value of the gripping (pushing) in the graph is only reference. Please note that there is a maximum variation of about 15%.

* Please note that, when gripping (pushing), the speed is fixed at 5mm/s.

Actuator Specifications

■ Lead and Load Capacity

Model	Deceleration Ratio	Max. Gripping Force (N)	Stroke (mm)
RCP2CR-GRSS-I-20P-30-8-①-②-③	30	14	8 (4 per side)

■ Stroke, Max. Opening/Closing Speed, and Suction Volume

Deceleration Ratio	Stroke 8 (mm)	Suction Volume (Nl/min)
30	78	10

(Unit: mm/s)

Legend: ① Compatible controllers ② Cable length ③ Options

Cable List

Type	Cable Symbol
Standard Type (Robot Cables)	P (1m)
	S (3m)
	M (5m)
Special Lengths	X06 (6m) ~ X10 (10m)
	X11 (11m) ~ X15 (15m)
	X16 (16m) ~ X20 (20m)

* The standard cable is the motor-encoder integrated robot cable.
* See page A-39 for cables for maintenance.

Actuator Specifications

Item	Description
Drive System	Worm gear + helical gear + helical rack
Positioning Repeatability	±0.01 mm
Backlash	0.2mm or less per side (constantly pressed out by a spring)
Lost Motion	0.05mm or less per side
Guide	Linear guide
Allowable Static Load Moment	Ma: 0.5N·m Mb: 0.5N·m Mc: 1.5N·m
Weight	0.2kg
Cleanliness	ISO class 4 (US FED STD class 10)
Ambient Operating Temp./Humidity	0~40°C, 85% RH or less (non-condensing)

Option List

Name	Option Code	See Page
Reversed-home	NM	→ A-33
Flange bracket	FB	→ A-26
Shaft bracket	SB	→ A-36

Dimensions

CAD drawings can be downloaded from IAI website. www.robocylinder.de



- * The opening side of the slider is the home position.
- * 1 The motor-encoder cable is connected here. See page A-39 for details on cables.

For Special Orders P. A-9

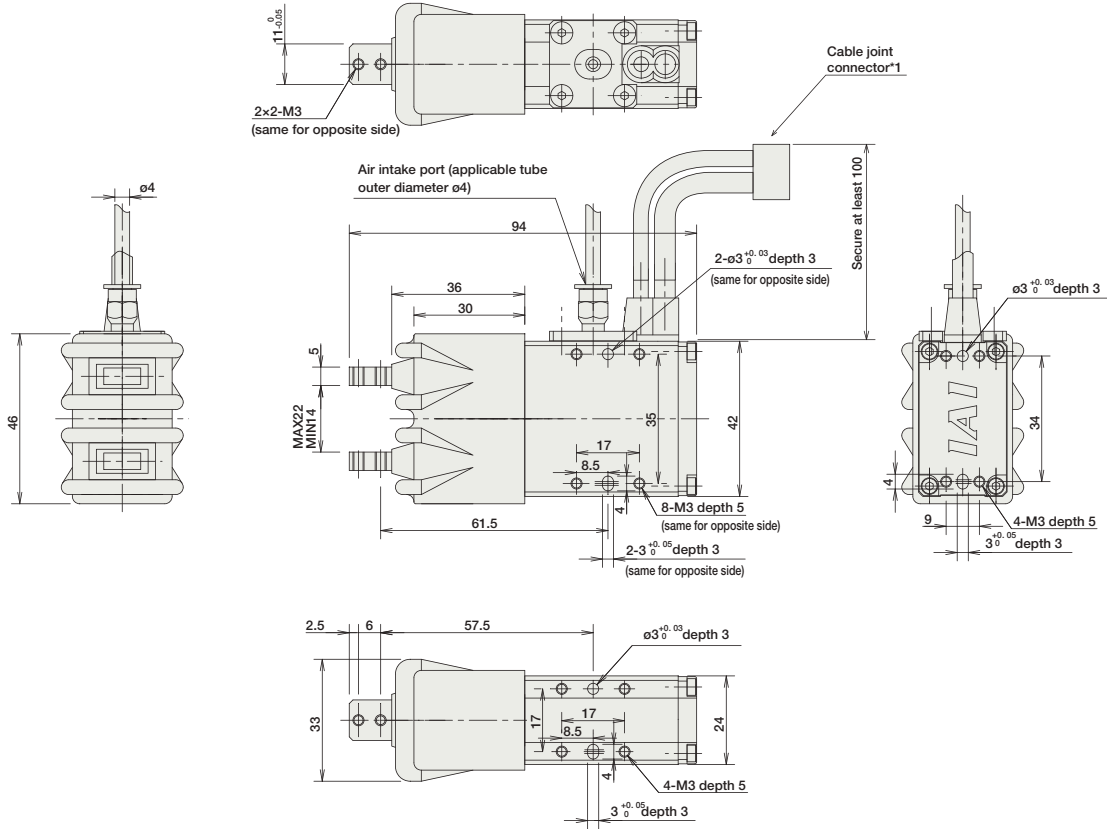

Weight (kg) 0.2

Compatible Controllers

The RCP2CR series actuators can operate with the controllers below. Select the controller according to your usage.

Name	External View	Model	Description	Max. Positioning Points	Input Voltage	Power Supply Capacity	See Page
Solenoid Valve Type		PMEC-C-20PI-NP-2-2	Easy-to-use controller, even for beginners	3 points	AC115V AC230V	See P481	→ P477
	Splash-Proof Solenoid Valve Type		PSEP-C-20PI-NP-2-0				
Positioner Type			PCON-C-20PI-NP-2-0	Positioning is possible for up to 512 points	512 points		
	Safety-Compliant Positioner Type		PCON-CG-20PI-NP-2-0				
Pulse Train Input Type (Differential Line Driver)		PCON-PL-20PI-NP-2-0	Pulse train input type with differential line driver support	(-)	DC24V	2A max.	→ P525
Pulse Train Input Type (Open Collector)		PCON-PO-20PI-NP-2-0	Pulse train input type with open collector support				
Serial Communication Type		PCON-SE-20PI-N-0-0	Dedicated to serial communication	64 points			
Field Network Type		RPOON-20P	Dedicated to field network	768 points			→ P503
Program Control Type		PSEL-C-1-20PI-NP-2-0	Programmed operation is possible. Operation is possible on up to 2 axes	1500 points			→ P557

* This is for the single-axis PSEL.

- Slider Type
- Mini
- Standard
- Controllers Integrated
- Rod Type
- Mini
- Standard
- Controllers Integrated
- Table/Arm /Flat Type
- Mini
- Standard
- Gripper/ Rotary Type
- Linear Motor Type
- Cleanroom Type
- Splash-Proof
- Controllers
- PMEC /AMEC
- PSEP /ASEP
- ROBO NET
- ERC2
- PCON
- ACON
- SCON
- PSEL
- ASEL
- SSEL
- XSEL
- Pulse Motor
- Servo Motor (24V)
- Servo Motor (230V)
- Linear Motor

- Slider Type
- Mini
- Standard
- Controllers Integrated
- Rod Type
- Mini
- Standard
- Controllers Integrated
- Table/Arm /Flat Type
- Mini
- Standard
- Gripper/ Rotary Type
- Linear Motor Type
- Cleanroom Type
- Splash-Proof
- Controllers
- PMEC /AMEC
- PSEP /ASEP
- ROBO NET
- ERC2
- PCON
- ACON
- SCON
- PSEL
- ASEL
- SSEL
- XSEL
- Pulse Motor
- Servo Motor (24V)
- Servo Motor (230V)
- Linear Motor

RCP2CR-GRLS Cleanroom RoboCylinder 2-Finger Gripper Mini Lever Type 42mm Width Pulse motor

■ Configuration: **RCP2CR** - **GRLS** - **I** - **20P** - **30** - **180** - - -

Series — Type — Encoder — Motor — Deceleration Ratio — Stroke — Compatible Controllers — Cable Length — Option

I: Incremental
 * The simple absolute encoder is also considered type "I".

20P: Pulse motor
 20 □ size

30: 1/30
 deceleration ratio

180 : 180 degrees
 (90 degrees per side)

P1: PCON
 RPCON
 PSEL
 P3: PMEC
 PSEP

N : None
 P : 1m
 S : 3m
 M : 5m
 X □ □ : Custom

NM: Reversed-home
 FB : Flange bracket
 SB : Shaft bracket

* See page Pre-35 for an explanation of the naming convention.

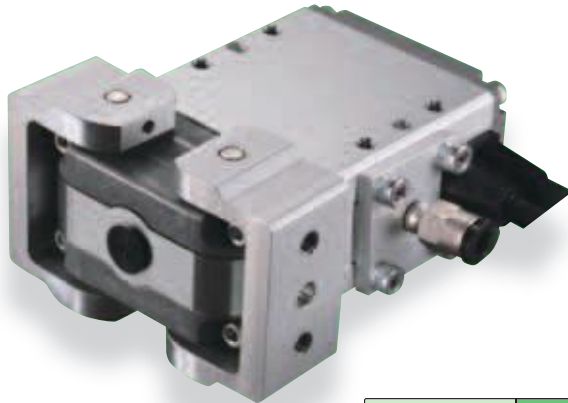

Technical References P. A-5

- POINT**
Notes on Selection
- (1) The maximum opening/closing speed indicates the operating speed on one side. The relative operating speed is twice this value.
 - (2) The maximum gripping force is the sum of the gripping forces of both fingers, at a gripping point distance of 0mm and no overhang distance. The workpiece weight that can be actually moved depends on the friction coefficient between the gripper fingers and the workpiece, as well as on the shape of the workpiece. As a rough guide, a workpiece's weight should not exceed 1/10 to 1/20 of the gripping force. (See page A-77 for details.)
 - (3) The rated acceleration while moving is 0.3G.

■ Gripping Force Adjustment
 The gripping (pushing) force can be adjusted freely within the range of current limits of 20% to 70%.

* The gripping forces in the following diagrams indicate the sum of the gripping forces of both fingers.

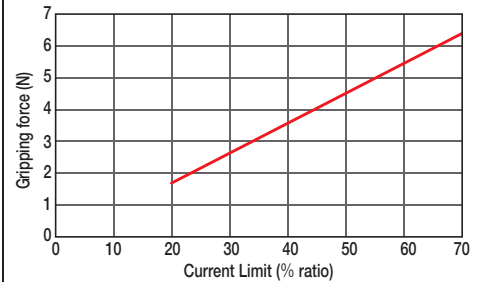

* The value of the gripping (pushing) in the graph is only reference. Please note that there is a maximum variation of about 15%.

* Please note that, when gripping (pushing), the speed is fixed at 5 degrees/s.

Actuator Specifications

Lead and Load Capacity

Model	Deceleration Ratio	Max. Gripping Force (N)	Stroke (deg)
RCP2CR-GRLS-I-20P-30-180-①-②-③	30	6.4	180 (90 per side)

Legend: ① Compatible controllers ② Cable length ③ Options

Stroke and Maxi. Opening/Closing Speed

Deceleration Ratio	Stroke	180 (deg)
	30	600

(Unit: degrees/s)

Cable List

Type	Cable Symbol
Standard Type (Robot Cables)	P (1m)
	S (3m)
	M (5m)
Special Lengths	X06 (6m) ~ X10 (10m)
	X11 (11m) ~ X15 (15m)
	X16 (16m) ~ X20 (20m)

* The standard cable is the motor-encoder integrated robot cable.

* See page A-39 for cables for maintenance.

Actuator Specifications

Item	Description
Drive System	Worm gear + helical gear
Positioning Repeatability	±0.01 mm
Backlash	1 degree or less per side (constantly pressed out by a spring)
Lost Motion	0.1 degree or less per side
Guide	-
Allowable Static Load Moment	-
Weight	0.2kg
Ambient Operating Temp./Humidity	0~40°C, 85% RH or less (non-condensing)

Option List

Name	Option Code	See Page
Reversed-home	NM	→ A-33
Flange bracket	FB	→ A-26
Shaft bracket	SB	→ A-36

Dimensions

CAD drawings can be downloaded from IAI website. www.robocylinder.de

For Special Orders P. A-9



* The opening side of the slider is the home position.
 *1 The motor-encoder cable is connected here. See page A-39 for details on cables.

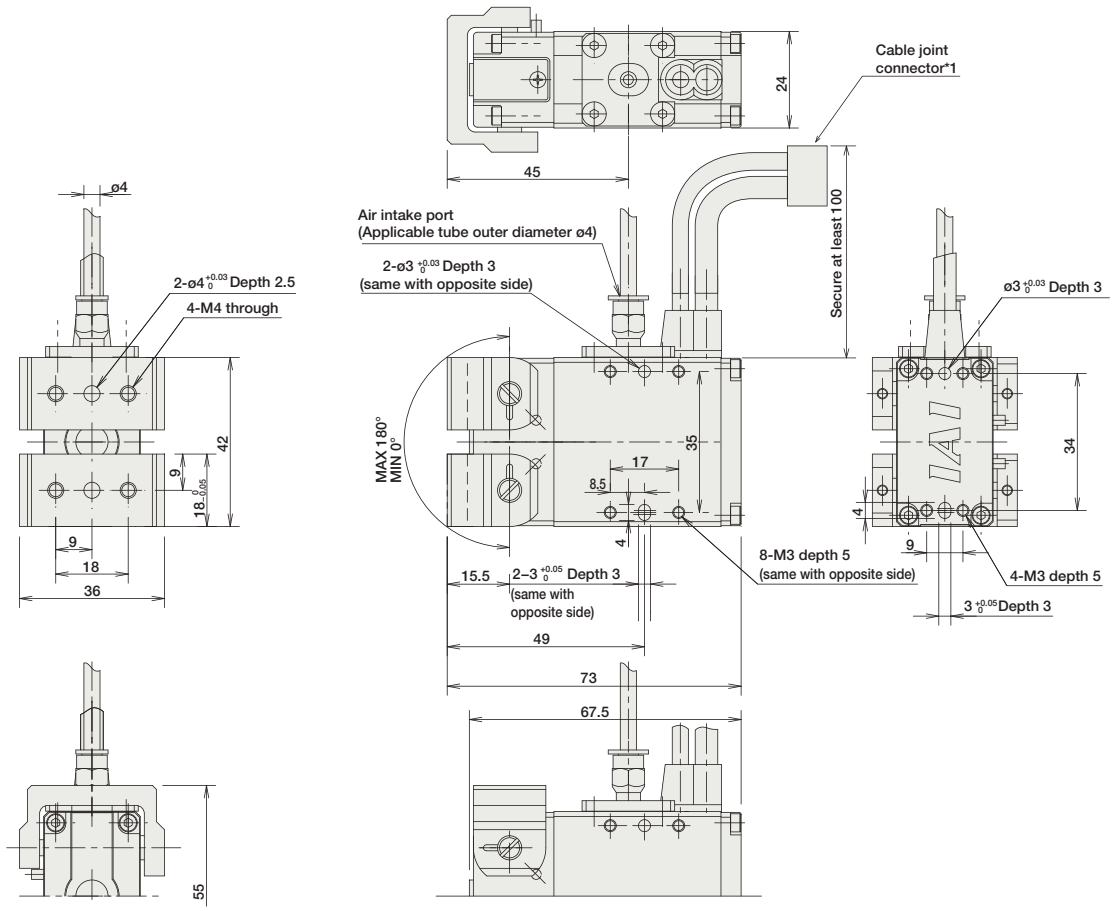

Weight (kg) 0.2

Compatible Controllers

The RCP2CR series actuators can operate with the controllers below. Select the controller according to your usage.

Name	External View	Model	Description	Max. Positioning Points	Input Voltage	Power Supply Capacity	See Page
Solenoid Valve Type		PMEC-C-20PI-NP-2-2	Easy-to-use controller, even for beginners	3 points	AC115V AC230V	See P481	→ P477
Splash-Proof Solenoid Valve Type		PSEP-C-20PI-NP-2-0 PSEP-CW-20PI-NP-2-0	Operable with same signal as solenoid valve. Supports both single and double solenoid types. No homing necessary with simple absolute type.				
Positioner Type		PCON-C-20PI-NP-2-0	Positioning is possible for up to 512 points	512 points	DC24V	2A max.	
Safety-Compliant Positioner Type		PCON-CG-20PI-NP-2-0					
Pulse Train Input Type (Differential Line Driver)		PCON-PL-20PI-NP-2-0	Pulse train input type with differential line driver support	(-)	DC24V	2A max.	→ P525
Pulse Train Input Type (Open Collector)		PCON-PO-20PI-NP-2-0	Pulse train input type with open collector support				
Serial Communication Type		PCON-SE-20PI-NI-0-0	Dedicated to serial communication	64 points	DC24V	2A max.	
Field Network Type		RPCON-20P	Dedicated to field network	768 points			
Program Control Type		PSEL-C-1-20PI-NP-2-0	Programmed operation is possible Operation is possible on up to 2 axes	1500 points	DC24V	2A max.	→ P557

* This is for the single-axis PSEL.

- Slider Type
- Mini
- Standard
- Controllers Integrated
- Rod Type
- Mini
- Standard
- Controllers Integrated
- Table/Arm /Flat Type
- Mini
- Standard
- Gripper/ Rotary Type
- Linear Motor Type
- Cleanroom Type
- Splash-Proof
- Controllers
- PMEC /AMEC
- PSEP /ASEP
- ROBO NET
- ERC2
- PCON
- ACON
- SCON
- PSEL
- ASEL
- SSEL
- XSEL
- Pulse Motor
- Servo Motor (24V)
- Servo Motor (230V)
- Linear Motor

RCP2W-SA16C

RoboCylinder Water-proof Slider Type 158mm Width Pulse Motor Coupled

■ Configuration: **RCP2W** — **SA16C** — **I** — **86P** — — — **P2** — —

Series — Type — Encoder — Motor — Lead — Stroke — Compatible Controllers — Cable Length — Option

I: Incremental Type 86P: Pulse motor 8 : 8mm 50 : 50mm P2: PCON-CF N : None CO : With Cover
 56 High Output 4 : 4mm 600 : 600mm (50mm pitch increments) S : 3m NM : Reversed-home
 M : 5m X : Custom Length R : Robot Cable

* See page Pre-35 for explanation of each code that makes up the configuration name.

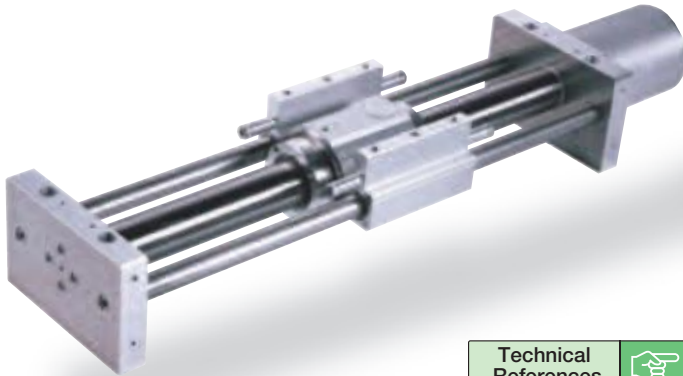

Technical References P. A-5

- POINT** Notes on Selection
- (1) The actuator is limited to being installed horizontally. Please note that it can't be used when installed in a wrong direction (transverse, vertical or reverse). (The same goes for storage.)
 - (2) When the stroke increases, the maximum speed will drop to prevent the ball screw from reaching the critical rotational speed. Use the actuator specification table below to check the maximum speed at the stroke you desire.
 - (3) Since the RCP2 series use a pulse motor, the load capacity decreases at high speeds. Check in the Speed vs. Load Capacity graph to see if your desired speed and load capacity are supported.
 - (4) The load capacity is based on operation at an acceleration of 0.2G. 0.2G is the upper limit for the acceleration.
 - (5) This actuator is not available to use push function mode.
 - (6) The cable joint connector is not splash-proof; secure it in a place that is not prone to water spills.

■ Speed vs. Load Capacity
 Due to the characteristics of the Pulse motor, the RCP2 series' load capacity decreases at high speeds. In the table below, check if your desired speed and load capacity are supported.

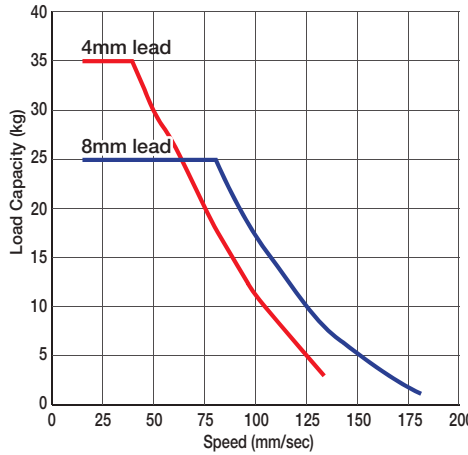

Actuator Specifications

■ Lead and Load Capacity (Note 1) Please note that the maximum load capacity decreases as the speed increases.

Model	Lead (mm)	Max. Load Capacity (Note 1)		Stroke (mm)
		Horizontal (kg)	Vertical (kg)	
RCP2W-SA16C-I-86P-8-①-P2-②-③	8	~25	Not Allowed	50~600 (50mm increments)
RCP2W-SA16C-I-86P-4-①-P2-②-③	4	~35		

■ Stroke and Maximum Speed

Stroke Lead	50~600 (50mm increments)	
	8	180
4	133	

(Unit: mm/s)

Legend ① Stroke ② Cable length ③ Options

Cable List

Type	Cable Symbol
Standard	P(1m)
	S(3m)
	M(5m)
Special Lengths	X06(6m) ~ X10(10m)
	X11(11m) ~ X15(15m)
	X16(16m) ~ X20(20m)
Robot Cable	R01(1m) ~ R03(3m)
	R04(4m) ~ R05(5m)
	R06(6m) ~ R10(10m)
	R11(11m) ~ R15(15m)
	R16(16m) ~ R20(20m)

* See page A-39 for cables for maintenance.

Actuator Specifications

Item	Description
Drive System	Ball screw ø12mm C10 grade
Positioning Repeatability	±0.08mm
Lost Motion	0.7 mm or less
Guide	ø20 Non-lubricated Linear Sliding Guide
Allowable Static Load Moment	20.0N·m
Overhang Load Length	Ma direction 200mm or less
Protection Structure	IP67
Ambient Operating Temp./Humidity	0~40°C, 85%RH or less (Non-condensing)

Note

A dynamic moment isn't applicable for the SA16C for structural reasons. When an object is to be mounted on the slider, please fix it in a manner so that no moment load is applied in the direction Mb or Mc, and so that the load is distributed evenly.

Option List

Name	Option Code	See Page
With cover	CO	→ 444
Reversed-home	NM	→ A-33

- Slider Type
- Mini
- Standard
- Controllers Integrated
- Rod Type
- Mini
- Standard
- Controllers Integrated
- Table/Arm /Flat Type
- Mini
- Standard
- Gripper/ Rotary Type
- Linear Motor Type
- Cleanroom Type
- Splash-Proof
- Controllers
- PMEC /AMEC
- PSEP /ASEP
- ROBO NET
- ERC2
- PCON
- ACON
- SCON
- PSEL
- ASEL
- SSEL
- XSEL

Dimensions

CAD drawings can be downloaded from IAI website. www.robocylinder.de

For Special Orders P. A-9

2/3D CAD

[No Cover]

4-9 drilled, $\phi 14$ counterbore, depth 8.5

※ For the reverse-home model, the dimensions (distance to home) on the motor-side and that on the opposite side are flipped.

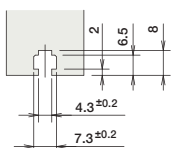
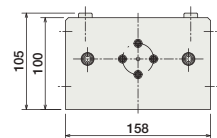
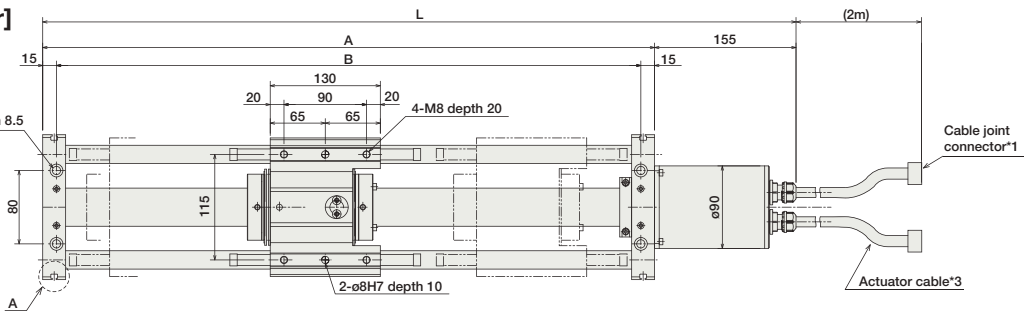

Details of A

*1 A motor-encoder cable is connected here. Please note that motor cable is the same as the one in the RCP2 series, but that the encoder cable is a dedicated type. The cable joint connector is not splash-proof; therefore, please secure it in a place that is not prone to water spills.

*2 When homing, the slider moves to the ME; therefore, please watch for any interference with the surrounding objects. ME: Mechanical end SE: Stroke end

*3 The actuator cable is not a robot cable (flex resistant cable); therefore, please don't use it for movable parts such as in cable track.

[With Cover] (Optional)

4-9 drilled, $\phi 14$ deep counterbore, depth 8.5

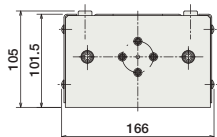
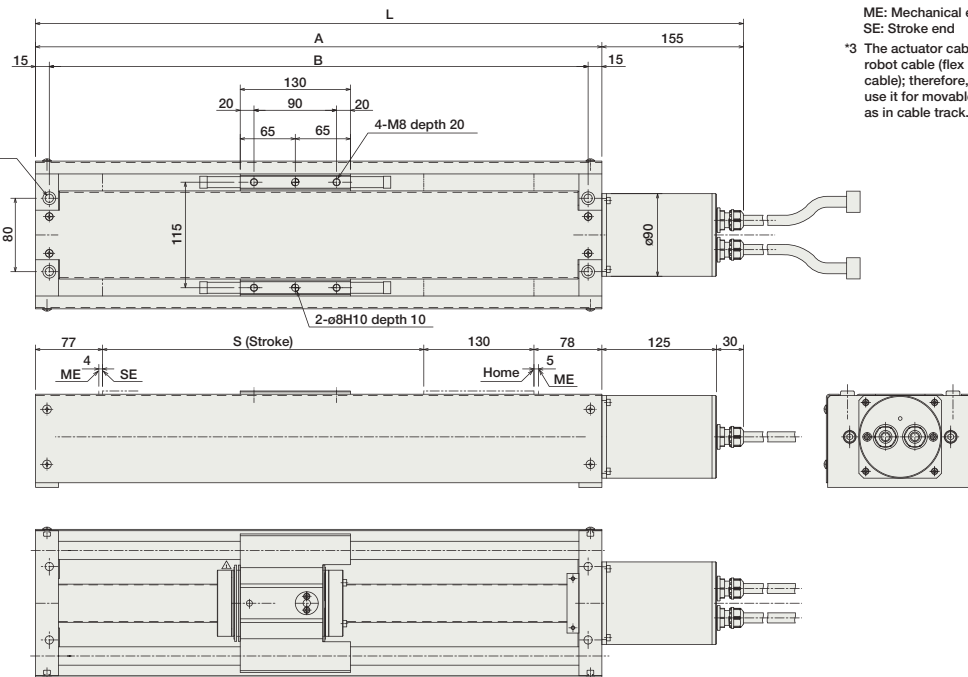

■ Dimensions/Weight by Stroke

Stroke	50	100	150	200	250	300	350	400	450	500	550	600
L	490	540	590	640	690	740	790	840	890	940	990	1040
A	335	385	435	485	535	585	635	685	735	785	835	885
B	305	355	405	455	505	555	605	655	705	755	805	855
S	50	100	150	200	250	300	350	400	450	500	550	600
Weight without cover (kg)	9	9.4	9.9	10.4	10.9	11.3	11.8	12.3	12.7	13.2	13.7	15.1
Weight with cover (kg)	10.5	11.1	11.8	12.5	13.2	13.8	14.6	15.3	15.9	16.6	17.3	18.9

Compatible Controllers

The controller for the RCP2W-SA16C type is a dedicated controller.

Name	External View	Model	Description	Max. Positioning Points	Input Voltage	Power Supply Capacity	See Page
Positioner Type		PCON-CF-86PI-NP-2-0	Positioning possible for up to 512 points	512 points	DC24V	6A max.	→ P525

Note: Please note that the encoder cable is a dedicated CF-type cable that is different from the PCON-C/CG/CY/PL/PO/SE controllers.

RCP2W-RA4C RoboCylinder Splash-proof Rod Type 45mm Width Pulse Motor Coupled

Configuration: RCP2W — RA4C — I — 42P — — — — —

Series — Type — Encoder — Motor — Lead — Stroke — Compatible Controllers — Cable Length — Option

I: Incremental Type 42P: Pulse motor 10: 10mm 50: 50mm P1: PCON N: None B: Brake-Equipped
 * The simple absolute encoder is also considered type "I". 42 □ size 5: 5mm 300: 300mm (50mm pitch increments) P: 1m P: 1m FL: With Flange
 PSEL M: 5m P3: PMEC X □ □: Custom FT: With Foot bracket
 PSEP R □ □: Robot Cable NM: Reversed-home

* See page Pre-35 for explanation of each code that makes up the configuration name.



Technical References P. A-5

- POINT** Notes on Selection
- When the stroke increases, the maximum speed will drop to prevent the ball screw from reaching the critical rotational speed. Use the actuator specification table below to check the maximum speed at the stroke you desire.
 - Since the RCP2 series use a pulse motor, the load capacity decreases at high speeds. Check in the Speed vs. Load Capacity graph on the above right to see if your desired speed and load capacity are supported.
 - The load capacity is based on operation at an acceleration of 0.2G. 0.2G is the upper limit for the acceleration.
 - The cable joint connector is not splash-proof; secure it in a place that is not prone to water spills.

Speed vs. Load Capacity
 Due to the characteristics of the Pulse motor, the RCP2 series' load capacity decreases at high speeds. In the table below, check if your desired speed and load capacity are supported.

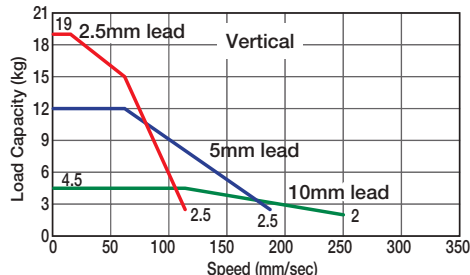
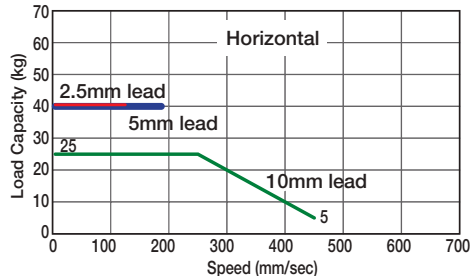

Actuator Specifications

Lead and Load Capacity

(Note 1) Please note that the maximum load capacity decreases as the speed increases.

Model	Lead (mm)	Max. Load Capacity (Note 1)		Maximum Push Force (N) (Note 2)	Stroke (mm)
		Horizontal (kg)	Vertical (kg)		
RCP2W-RA4C-I-42P-10-①-②-③-④	10	~25	~4.5	150	50-300 (50mm increments)
RCP2W-RA4C-I-42P-5-①-②-③-④	5	40	~12	284	
RCP2W-RA4C-I-42P-2.5-①-②-③-④	2.5	40	~19	358	

Legend ① Stroke ② Compatible controller ③ Cable length ④ Options

(Note 2) See page A-69 for push force graph.

Stroke and Maximum Speed

Stroke / Lead	50-200 (50mm increments)		
	250	300	350
10	450 (<250>)	450 (<250>)	350 (<250>)
5	190	190	175
2.5	125 (<115>)	115	85

* The value inside < > applies to vertical setting. (Unit: mm/s)

Cable List

Type	Cable Symbol
Standard	P (1m)
	S (3m)
	M (5m)
Special Lengths	X06 (6m) ~ X10 (10m)
	X11 (11m) ~ X15 (15m)
	X16 (16m) ~ X20 (20m)
Robot Cable	R01 (1m) ~ R03 (3m)
	R04 (4m) ~ R05 (5m)
	R06 (6m) ~ R10 (10m)
	R11 (11m) ~ R15 (15m)
	R16 (16m) ~ R20 (20m)

* See page A-39 for cables for maintenance.

Actuator Specifications

Item	Description
Drive System	Ball screw ø8mm C10 grade
Positioning Repeatability	±0.02mm
Lost Motion	0.1 mm or less
Rod diameter	ø22mm
Rod non-rotational accuracy	±1.5 degrees
Protection Structure	IP65
Ambient Operating Temp./Humidity	0~40°C, 85%RH or less (Non-condensing)

Option List

Name	Option Code	See Page
Brake-Equipped	B	→ A-25
With Flange	FL	→ A-27
With Foot bracket	FT	→ A-29
Reversed-home	NM	→ A-33

Dimensions

CAD drawings can be downloaded from IAI website. www.robocylinder.de



For Special Orders P. A-9

Note:
Please don't apply an external force coming from a direction other than that of the rod's advance. The rotation stopper may break if a force coming from right angle or rotating direction is applied to the rod.

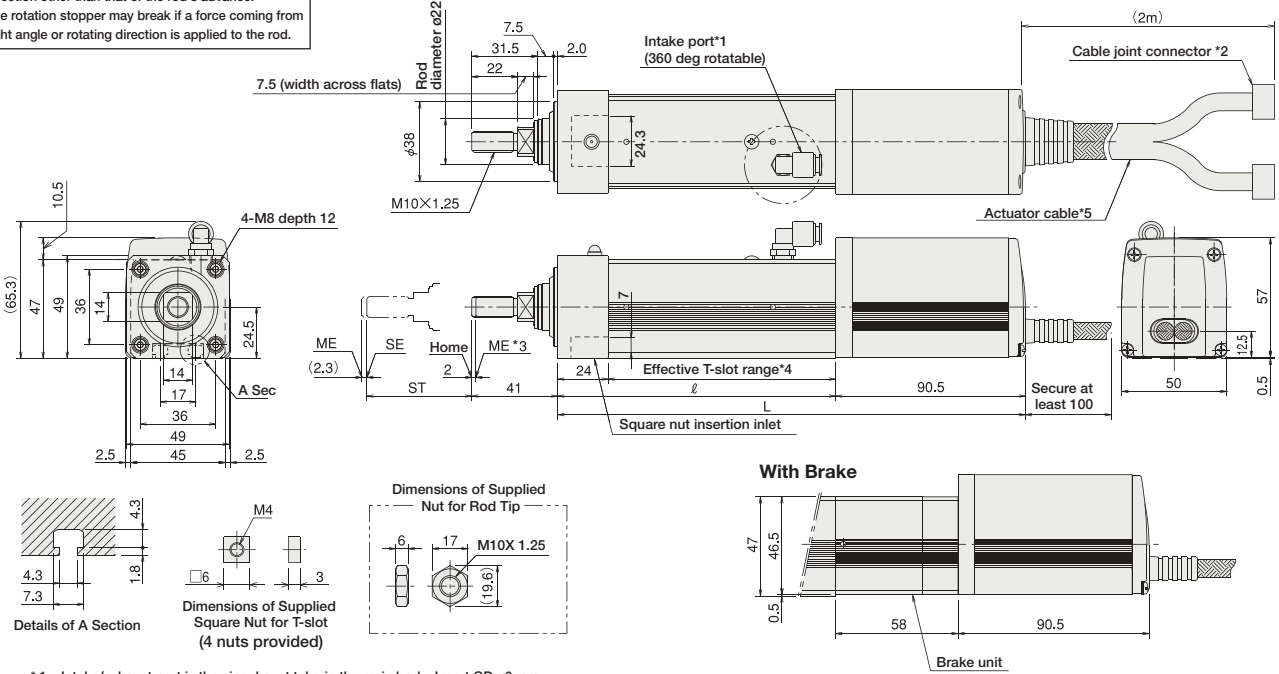

- * 1. Intake/exhaust port is the air exhaust tube in the main body. Insert OD $\phi 6$ mm tube and use it extended to a place that is not prone to water spills or intake.
- * 2. Connect motor encoder cable. See page A-39 for details on cables. **The cable joint connector is not splash-proof; therefore, please secure it in a place that is not prone to water spills.**
- * 3. When homing, the rod moves to the ME; therefore, please watch for any interference with the surrounding objects.
ME : Mechanical End
SE : Stroke end
The dimensions enclosed in "()" are reference dimensions.
- * 4. Please note that there is no T-slot in the bottom of brake unit.
- * 5. The actuator cable is not a robot cable (flex resistant cable); therefore, please don't use it for movable parts such as cable track.

* Adding a brake increases overall length by 58mm and its weight by 0.4kg.

■ Dimensions/Weight by Stroke

Stroke	50	100	150	200	250	300
ℓ	132.5	182.5	232.5	282.5	332.5	382.5
L	223	273	323	373	423	473
Weight (kg)	1.9	2.1	2.2	2.5	2.9	3.1

Compatible Controllers

The RCP2W series actuators can operate with the controllers below. Select the controller according to your usage.

Name	External View	Model	Description	Max. Positioning Points	Input Voltage	Power Supply Capacity	See Page
Solenoid Valve Type		PMEC-C-42PI-NP-2-2	Easy-to-use controller, even for beginners.	3 points	AC115V AC230V	See P481	→ P477
		PSEP-C-42PI-NP-2-0	Operable with same signal as solenoid valve. Supports both single and double solenoid types. No homing necessary with simple absolute type.				→ P487
Splash-Proof Solenoid Valve Type		PSEP-CW-42PI-NP-2-0					
Positioner Type		PCON-C-42PI-NP-2-0	Positioning possible for up to 512 points	512 points	DC24V	2A max.	
Safety Category Compliant Positioner Type		PCON-CG-42PI-NP-2-0					
Pulse Train Input Type (Differential Line Driver)		PCON-PL-42PI-NP-2-0	Differential line driver support Pulse Train Input Type	(-)	DC24V	2A max.	→ P525
Pulse Train Input Type (Open Collector)		PCON-PO-42PI-NP-2-0	Open Collector Pulse Train Input Type				
Serial Communication Type		PCON-SE-42PI-N-0-0	Dedicated to serial communication	64 points			
Field Network Type		RPCON-42P	Dedicated to field network	768 points			→ P503
Program Control Type		PSEL-C-1-42PI-NP-2-0	Programmed operation is possible Can operate up to 2 axes	1500 points			→ P557

* This is for the single-axis PSEL.

- Slider Type
- Mini
- Standard
- Controllers Integrated
- Rod Type
- Mini
- Standard
- Controllers Integrated
- Table/Arm /Flat Type
- Mini
- Standard
- Gripper/ Rotary Type
- Linear Motor Type
- Cleanroom Type
- Splash-Proof
- Controllers
- PMEC /AMEC
- PSEP /ASEP
- ROBO NET
- ERC2
- PCON
- ACON
- SCON
- PSEL
- ASEL
- SSEL
- XSEL
- Pulse Motor
- Servo Motor (24V)
- Servo Motor (230V)
- Linear Motor

RCP2W-RA6C

RoboCylinder Splash-proof Rod Type 64mm Width Pulse Motor Coupled

Configuration: RCP2W — RA6C — I — 56P

Series — Type — Encoder — Motor — Lead — Stroke — Compatible Controllers — Cable Length — Option

I: Incremental Type 56P: Pulse motor
 * The simple absolute encoder is also considered type "I".

16 : 16mm 50: 50mm
 8 : 8mm 300: 300mm (50mm pitch increments)
 4 : 4mm

P1 : PCON
 RPCON
 PSEL
 P3 : PMEC
 PSEP

N : None
 P : 1m
 S : 3m
 M : 5m
 X : Custom Length
 R : Robot Cable

B : Brake-Equipped
 FL : With Flange
 FT : With Foot bracket
 NM : Reversed-home

* See page Pre-35 for explanation of each code that makes up the configuration name.



Technical References P. A-5

- POINT**
Notes on Selection
- When the stroke increases, the maximum speed will drop to prevent the ball screw from reaching the critical rotational speed. Use the actuator specification table below to check the maximum speed at the stroke you desire.
 - Since the RCP2 series use the pulse motor, the load capacity decreases at high speeds. Check in the Speed vs. Load Capacity graph on the above right to see if your desired speed and load capacity are supported.
 - The load capacity is based on operation at an acceleration of 0.2G. 0.2G is the upper limit for the acceleration.
 - The cable joint connector is not splash-proof; secure it in a place that is not prone to water spills.

Speed vs. Load Capacity
 Due to the characteristics of the Pulse motor, the RCP2 series' load capacity decreases at high speeds. In the table below, check if your desired speed and load capacity are supported.

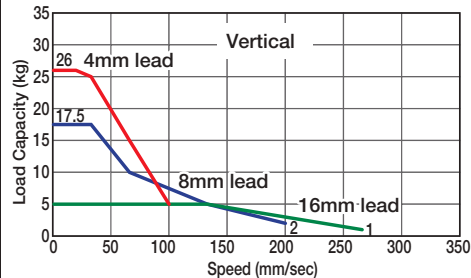
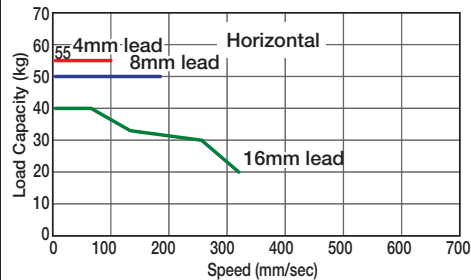

Actuator Specifications

Lead and Load Capacity

(Note 1) Please note that the maximum load capacity decreases as the speed increases.

Model	Lead (mm)	Max. Load Capacity (Note 1)		Maximum Push Force (N) (Note 2)	Stroke (mm)
		Horizontal (kg)	Vertical (kg)		
RCP2W-RA6C-I-56P-16-①-②-③-④	16	~40	~5	240	50-300 (50mm increments)
RCP2W-RA6C-I-56P-8-①-②-③-④	8	50	~17.5	470	
RCP2W-RA6C-I-56P-4-①-②-③-④	4	55	~26	800	

Legend ① Stroke ② Compatible controller ③ Cable length ④ Options

(Note 2) See page A-69 for push force graph.

Stroke and Maximum Speed

Lead	Stroke	50-300 (50mm increments)
		16
8	200	
4	100	

* The value inside < > applies to vertical setting. (Unit: mm/s)

Cable List

Type	Cable Symbol
Standard	P (1m)
	S (3m)
	M (5m)
Special Lengths	X06 (6m) ~ X10 (10m)
	X11 (11m) ~ X15 (15m)
	X16 (16m) ~ X20 (20m)
Robot Cable	R01 (1m) ~ R03 (3m)
	R04 (4m) ~ R05 (5m)
	R06 (6m) ~ R10 (10m)
	R11 (11m) ~ R15 (15m)
	R16 (16m) ~ R20 (20m)

* See page A-39 for cables for maintenance.

Actuator Specifications

Item	Description
Drive System	Ball screw ø12mm C10 grade
Positioning Repeatability	±0.02mm
Lost Motion	0.1 mm or less
Rod diameter	ø30mm
Rod non-rotational accuracy	±1.0 degrees
Protection Structure	IP65
Ambient Operating Temp./Humidity	0~40°C, 85%RH or less (Non-condensing)

Option List

Name	Option Code	See Page
Brake-Equipped	B	→ A-25
With Flange	FL	→ A-27
With Foot bracket	FT	→ A-29
Reversed-home	NM	→ A-33

Dimensions

CAD drawings can be downloaded from IAI website. www.robocylinder.de

For Special Orders P. A-9



Note:
Please don't apply an external force coming from a direction other than that of the rod's advance. The rotation stopper may break if a force coming from right angle or rotating direction is applied to the rod.

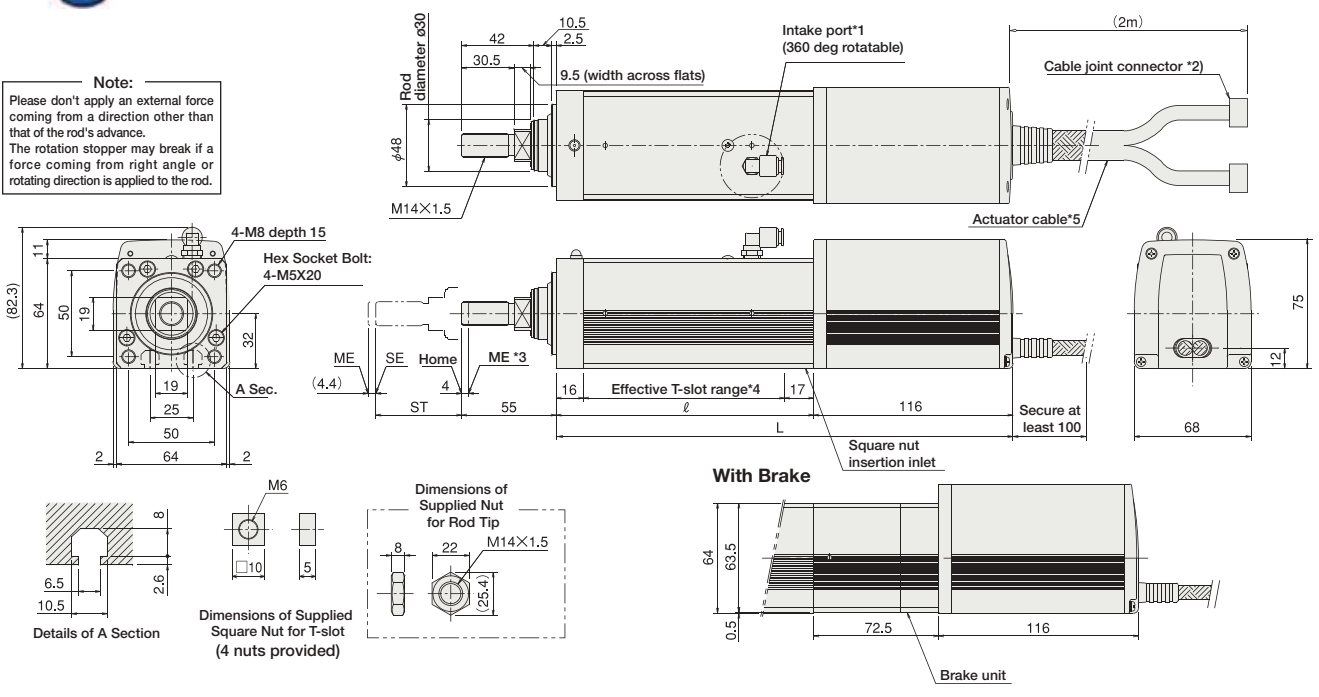

- *1. Intake/exhaust port is the air exhaust tube in the main body. Insert OD $\phi 6$ mm tube and use it extended to a place that is not prone to water spills or intake.
- *2. Connect motor encoder cable. See page A-39 for details on cables.
The cable joint connector is not splash-proof; therefore, please secure it in a place that is not prone to water spills.
- *3. When homing, the rod moves to the ME; therefore, please watch for any interference with the surrounding objects.
ME: Mechanical End
SE: Stroke end
The dimensions enclosed in "()" are reference dimensions.
- *4. Please note that there is no T-slot in the bottom of brake unit.
- *5. The actuator cable is not a robot cable (flex resistant cable); therefore, please don't use it for movable parts such as cable track.

* Adding a brake increases overall length by 72.5mm and its weight by 0.9kg.

■ Dimensions/Weight by Stroke

Stroke	50	100	150	200	250	300
ℓ	150	200	250	300	350	400
L	266	316	366	416	466	516
Weight (kg)	3.5	4.0	4.5	5.0	5.5	6.0

Compatible Controllers

The RCP2W series actuators can operate with the controllers below. Select the controller according to your usage.

Name	External View	Model	Description	Max. Positioning Points	Input Voltage	Power Supply Capacity	See Page	
Solenoid Valve Type		PMEC-C-56PI-NP-2-2	Easy-to-use controller, even for beginners.	3 points	AC115V AC230V	See P481	→ P477	
Splash-Proof Solenoid Valve Type		PSEP-C-56PI-NP-2-0	Operable with same signal as solenoid valve. Supports both single and double solenoid types. No homing necessary with simple absolute type.				→ P487	
Positioner Type		PCON-C-56PI-NP-2-0	Positioning possible for up to 512 points				512 points	DC24V
Safety Category Compliant Positioner Type		PCON-CG-56PI-NP-2-0						
Pulse Train Input type (Differential Line Driver)		PCON-PL-56PI-NP-2-0	Differential line driver support Pulse Train Input Type	(-)	DC24V	2A max.	→ P525	
Pulse Train Input Type (Open Collector)		PCON-PO-56PI-NP-2-0	Open Collector Pulse Train Input Type					
Serial Communication Type		PCON-SE-56PI-N-0-0	Dedicated to serial communication	64 points	DC24V	2A max.		
Field Network Type		RPCON-56P	Dedicated to field network	768 points				→ P503
Program Control Type		PSEL-C-1-56PI-NP-2-0	Programmed operation is possible Can operate up to 2 axes	1500 points				→ P557

* This is for the single-axis PSEL.

RCP2W-RA10C RoboCylinder High-thrust Dust-proof Rod Type 100mm Width Pulse Motor Coupled

Configuration: RCP2W — RA10C — I — 86P — — — P2 — —
 Series — Type — Encoder — Motor — Lead — Stroke — Compatible Controllers — Cable Length — Option
 I: Incremental Type 86P: Pulse motor 86 size 10 : 10mm 5 : 5mm 2.5 : 2.5mm 50: 50mm 300: 300mm (50mm pitch increments) P2 : PCON-CF N : None A1-A3 : Connector cable Cable outlet direction changed B : Brake-Equipped FL : With Flange FT : With Foot bracket X : Custom Length R : Robot Cable

* See page Pre-35 for explanation of each code that makes up the configuration name.

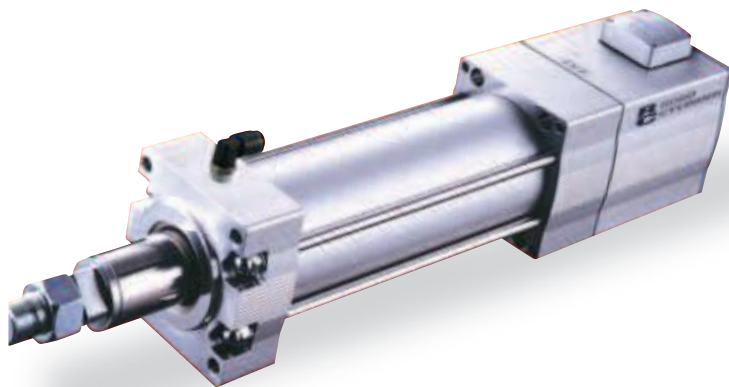

Technical References P. A-5

- POINT** Notes on Selection
- (1) Minimum speed is set for each lead. (Lead 10: 10mm/s, Lead 5: 5mm/s, Lead 2.5: 1mm/s) Please note that vibration etc. may occur when operated at minimum speed.
 - (2) Since the RCP2 series use a pulse motor, the load capacity decreases at high speeds. Check the Speed vs. Load Capacity on the right hand graph to see if your desired speed and load capacity are supported.
 - (3) The load capacity is based on operation at lead 10: 0.04G, lead 5: 0.02G and lead 2.5: 0.01G. These values are the upper limits for the acceleration. Also, this is when the load capacity is attached to the external guide. The rotation stopper may break if an external force coming from a direction other than that of rod's advance is applied.
 - (4) The cable joint connector is not splash-proof; secure it in a place that is not prone to water spills.

Speed vs. Load Capacity
 Due to the characteristics of the Pulse motor, the RCP2 series' load capacity decreases at high speeds. In the table below, check if your desired speed and load capacity are supported.

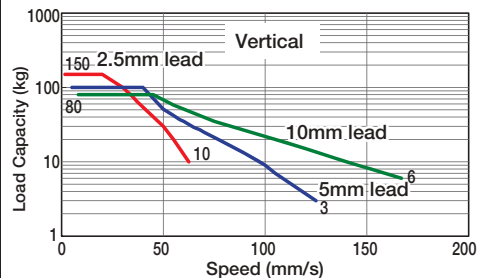
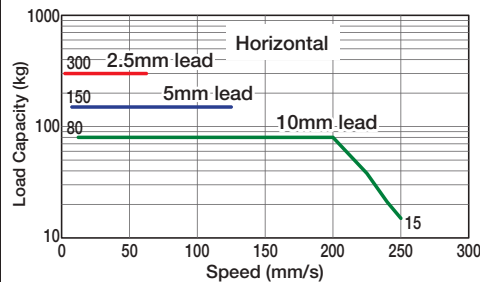

Actuator Specifications

Lead and Load Capacity

(Note 1) Please note that the maximum load capacity decreases as the speed increases.

Model	Lead (mm)	Max. Load Capacity (Note 1)		Maximum Push Force (N) (Note 2)	Stroke (mm)
		Horizontal(kg)	Vertical(kg)		
RCP2W-RA10C-I-86P-10-①-P2-②-③	10	~80	~80	1500	50-300 (50mm increments)
RCP2W-RA10C-I-86P-5-①-P2-②-③	5	150	~100	3000	
RCP2W-RA10C-I-86P-2.5-①-P2-②-③	2.5	300	~150	6000	

Legend ① Stroke ② Cable length ③ Options

(Note 2) See page A-70 for push force graph.

Stroke and Maximum Speed

Lead	Stroke and Maximum Speed	
	Stroke (mm)	50-300 (50mm increments)
10	250	<167>
5	125	
2.5	63	

* The value inside < > applies to vertical setting. (Unit: mm/s)

Cable List

Type	Cable Symbol
Standard	P (1m)
	S (3m)
	M (5m)
Special Lengths	X06 (6m) ~ X10 (10m)
	X11 (11m) ~ X15 (15m)
	X16 (16m) ~ X20 (20m)
Robot Cable	R01 (1m) ~ R03 (3m)
	R04 (4m) ~ R05 (5m)
	R06 (6m) ~ R10 (10m)
	R11 (11m) ~ R15 (15m)
	R16 (16m) ~ R20 (20m)

* See page A-39 for cables for maintenance.

Actuator Specifications

Item	Description
Drive System	Ball screw C10 grade
Positioning Repeatability	±0.02mm
Lost Motion	0.1 mm or less
Rod diameter	ø40mm
Rod non-rotational accuracy	±1.0 degrees
Protection Structure	IP54
Ambient Operating Temp./Humidity	0~40°C, 85%RH or less (Non-condensing)

Option List

Name	Option Code	See Page
Connector cable outlet direction changed	A1-A3	→ A-25
Brake	B	→ A-25
Flange	FL	→ A-27
Foot bracket	FT	→ A-29

Dimensions

CAD drawings can be downloaded from IAI website. www.robocylinder.de

For Special Orders P. A-9



* Please note that reversed home position is unavailable for the RA10C type for structural reasons.

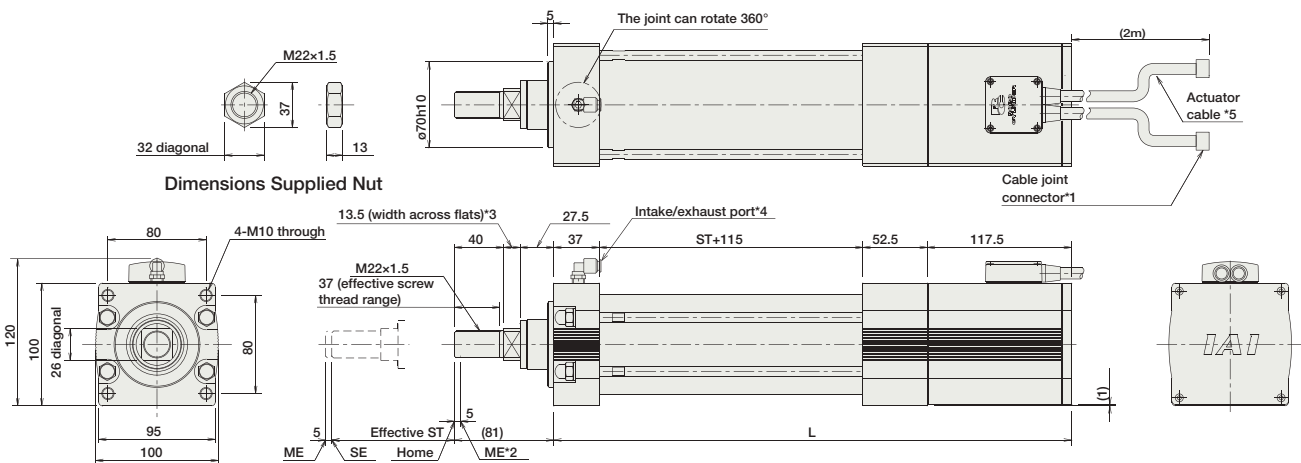

Dimensions Supplied Nut

- *1. A motor-encoder cable is connected here. Please note that motor cable is the same as the one in the RCP2 series, but that the encoder cable is a dedicated type. See page A-39 for details on cables. **The cable joint connector is not splash-proof; therefore, please secure it in a place that is not prone to water spills.**
- *2. When homing, the rod moves to the ME; therefore, please watch for any interference with the surrounding objects. ME: Mechanical end SE: Stroke end The dimensions enclosed in "()" are reference dimensions.
- *3. The direction of across-flats will vary depending on the product.
- *4. Intake/exhaust port is the air exhaust tube in the main body.
- *5. The actuator cable is not a robot cable (flex resistant cable); therefore, please don't use it for movable parts such as cable track.

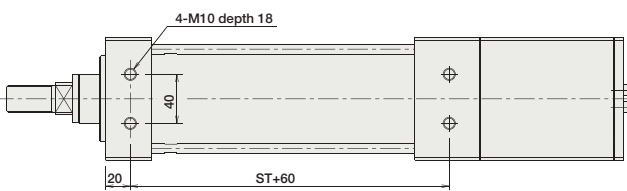

Dimensions of the Brake Section

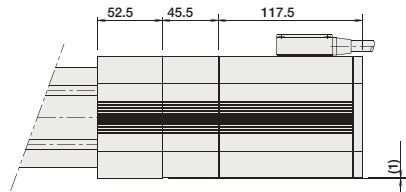

* Adding a brake increases overall length by 45.5mm and its weight by 1.5kg.

Dimensions/Weight by Stroke

Stroke	50	100	150	200	250	300
L	372	422	472	522	572	622
Weight (kg)	9	9.5	10	10.5	11	11.5

Compatible Controllers

The controller for the RCP2W-RA10C type is a dedicated controller.

Name	External View	Model	Description	Max. Positioning Points	Input Voltage	Power Supply Capacity	See Page
Positioner Type		PCON-CF-86PI-NP-2-0	Positioning possible for up to 512 points	512 points	DC24V	6A max.	→ P525

Note: Please note that the encoder cable is a dedicated CF-type cable that is different from the PCON-C/CG/CY/PL/PO/SE controllers.

- Slider Type
- Mini
- Standard
- Controllers Integrated
- Rod Type
- Mini
- Standard
- Controllers Integrated
- Table/Arm /Flat Type
- Mini
- Standard
- Gripper/ Rotary Type
- Linear Motor Type
- Cleanroom Type
- Splash-Proof
- Controllers
- PMEC /AMEC
- PSEP /ASEP
- ROBO NET
- ERC2
- PCON
- ACON
- SCON
- PSEL
- ASEL
- SSEL
- XSEL
- Pulse Motor
- Servo Motor (24V)
- Servo Motor (230V)
- Linear Motor

RCP2W-GRSS

RoboCylinder 2-Finger Gripper Dust-proof Mini Slider Type 42mm Width Pulse Motor

■ Configuration: **RCP2W** — **GRSS** — **I** — **20P** — **30** — **8** — — —

Series — Type — Encoder — Motor — Lead — Stroke — Compatible Controllers — Cable Length — Option

I: Incremental Type 20P: Pulse motor 30: Deceleration 8: 8mm
 * The simple absolute encoder is also considered type "I".
 20 size ratio 1/30 (One side 4mm)
 P1 : PCON N : None NM : Reversed-home
 RPCON P : 1m FB : Flange Bracket
 PSEL S : 3m M : 5m SB : Shaft Bracket
 P3 : PMEC X : Custom Length
 PSEP

* See page Pre-35 for explanation of each code that makes up the configuration name.



Technical References P. A-5

■ Grip Force Arrangement
 Through push operation the grip force (push force) can be arranged freely within the range of 20%-70% of current limit value of the controller.
 * Grip force noted in the figure below is the sum of the grip force of two fingers.

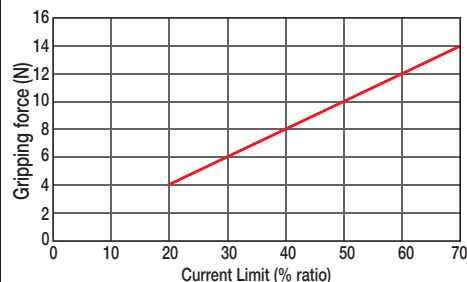

* The value of the gripping (pushing) in the graph is only reference. Please note that there is a maximum variation of about 15%.

* Please note when gripping (pushing) is performed the speed will be fixed at 5 mm/s.

- POINT**
Notes on Selection
- (1) The max. open/close speed represents one side operating speed.
 - (2) The max. grip force will be the sum of the two fingers grip force when the distance for grip point and overhang is 0. The actual work part weight which can be transported depends on the friction constant between finger and work material, and the form; typically it is 1/10-1/20 or less than gripping force. (See page A-74 for details.)
 - (3) The rated acceleration at transportation is 0.3G.
 - (4) Please note that the product has no splash-proof function.

Actuator Specifications

Lead and Load Capacity

Model	Deceleration ratio	Max. Grip Force (N)	Stroke (mm)
RCP2W-GRSS-I-20P-30-8-①-②-③	30	14	8 (One side 4)

Legend ① Compatible controller ② Cable length ③ Options

Stroke and Maximum Open/Close Speed

Deceleration ratio	Stroke 8 (mm)
30	78

(Unit: mm/s)

Cable List

Type	Cable Symbol
Standard (Robot Cables)	P (1m)
	S (3m)
	M (5m)
Special Lengths	X06 (6m) ~ X10 (10m)
	X11 (11m) ~ X15 (15m)
	X16 (16m) ~ X20 (20m)

* The standard cable is the motor-encoder integrated robot cable.
 * See page A-39 for cables for maintenance.

Actuator Specifications

Item	Description
Drive System	Worm gear + Helical gear + Helical rack
Positioning Repeatability	±0.01mm
Backlash	0.2 mm or less for one side (stressed by spring on the side which is opened always)
Lost Motion	0.05mm or less one side
Guide	Linear Guide
Statically Allowable Load Moment	Ma:0.5N·m Mb:0.5N·m Mc:1.5N·m
Weight	0.2kg
Protection Structure	IP50
Ambient Operating Temp./Humidity	0~40°C, 85%RH or less (Non-condensing)

Option List

Name	Option Code	See Page
Reversed-home	NM	→ A-33
Flange Bracket	FB	→ 26
Shaft Bracket	SB	→ 36

Dimensions

CAD drawings can be downloaded from IAI website. www.robocylinder.de

For Special Order  P. A-9



- * Open side of slider will be home position.
- *1 A motor-encoder cable is connected here. See page A-39 for details on cables.

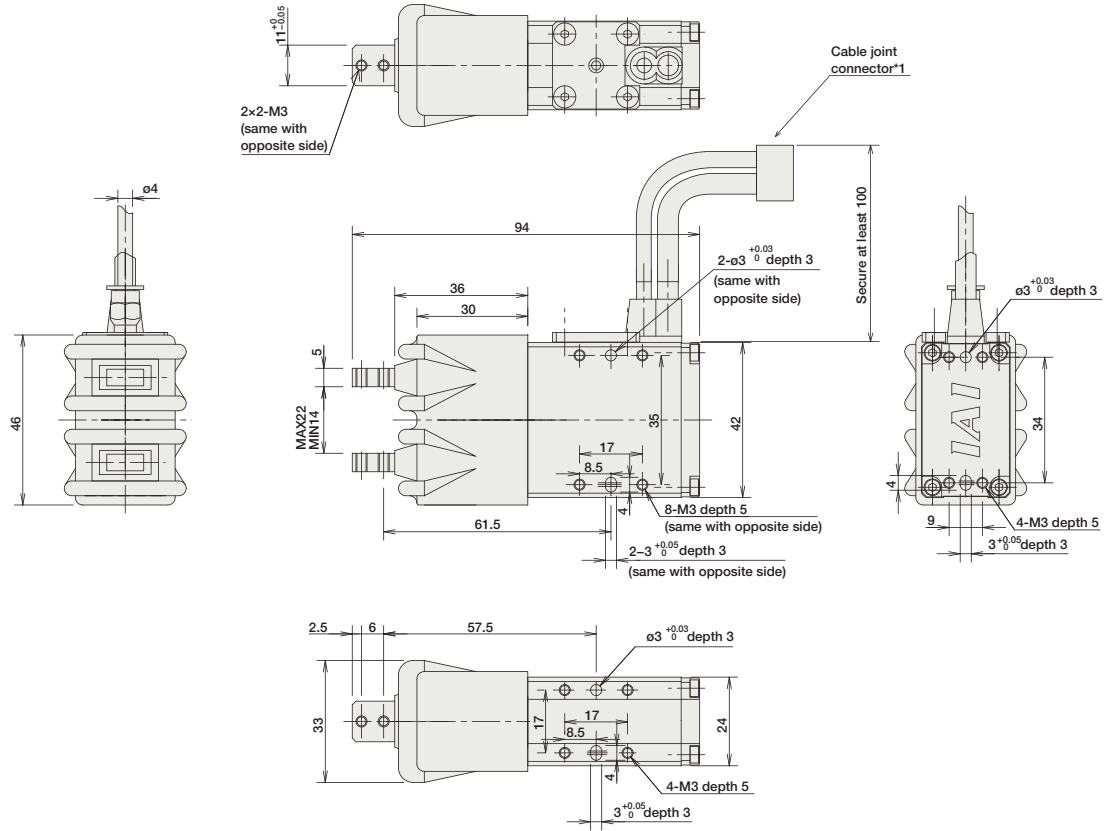

Weight (kg) 0.2

Compatible Controllers

The RCP2W series actuators can operate with the controllers below. Select the controller according to your usage.

Name	External View	Model	Description	Max. Positioning Points	Input Voltage	Power Supply Capacity	See Page
Solenoid Valve Type		PMEC-C-20PI-NP-2-2	Easy-to-use controller, even for beginners.	3 points	AC115V AC230V	See P481	→ P477
Splash-Proof Solenoid Type		PSEP-C-20PI-NP-2-0	Operable with same signal as solenoid valve. Supports both single and double solenoid types. No homing necessary with simple absolute type.				→ P487
Positioner Type		PCON-C-20PI-NP-2-0	Positioning possible for up to 512 points	512 points	DC24V	2A max.	
Safety Category Compliant Positioner Type		PCON-CG-20PI-NP-2-0					
Pulse Train Input Type (Differential Line Driver)		PCON-PL-20PI-NP-2-0	Differential line driver support Pulse Train Input Type	(-)	DC24V	2A max.	→ P525
Pulse Train Input Type (Open Collector)		PCON-PO-20PI-NP-2-0	Open Collector Pulse Train Input Type				
Serial Communication Type		PCON-SE-20PI-N-0-0	Dedicated to serial communication	64 points			
Field Network Type		RPCON-20P	Dedicated to field network	768 points			→ P503
Program Control Type		PSEL-C-1-20PI-NP-2-0	Programmed operation is possible Can operate up to 2 axes	1500 points			→ P557

* This is for the single-axis PSEL.

- Slider Type
- Mini
- Standard
- Controllers Integrated
- Rod Type
- Mini
- Standard
- Controllers Integrated
- Table/Arm /Flat Type
- Mini
- Standard
- Gripper/ Rotary Type
- Linear Motor Type
- Cleanroom Type
- Splash-Proof
- Controllers
- PMEC /AMEC
- PSEP /ASEP
- ROBO NET
- ERC2
- PCON
- ACON
- SCON
- PSEL
- ASEL
- SSEL
- XSEL
- Pulse Motor
- Servo Motor (24V)
- Servo Motor (230V)
- Linear Motor

- Slider Type
- Mini
- Standard
- Controllers Integrated
- Rod Type
- Mini
- Standard
- Controllers Integrated
- Table/Arm /Flat Type
- Mini
- Standard
- Gripper/ Rotary Type
- Linear Motor Type
- Cleanroom Type
- Splash-Proof
- Controllers
- PMEC /AMEC
- PSEP /ASEP
- ROBO NET
- ERC2
- PCON
- ACON
- SCON
- PSEL
- ASEL
- SSEL
- XSEL
- Pulse Motor
- Servo Motor (24V)
- Servo Motor (230V)
- Linear Motor

RCP2W-GRLS RoboCylinder 2-Finger Gripper Dust-proof Mini Lever Type 42mm Width Pulse Motor

■ Configuration: **RCP2W** — **GRLS** — **I** — **20P** — **30** — **180** — — —

Series — Type — Encoder — Motor — Lead — Stroke — Compatible Controllers — Cable Length — Option

I: Incremental Type 20P: Pulse motor 30: Deceleration ratio 1/30 180: 180 Degrees (One side 90 degrees)

* The simple absolute encoder is also considered type "I".

P1: PCON N: None NM: Reversed-home
 RPCON P: 1m FB: Flange Bracket
 PSEL S: 3m SB: Shaft Bracket
 P3: PMEC M: 5m
 PSEP X : Custom Length

* See page Pre-35 for explanation of each code that makes up the configuration name.

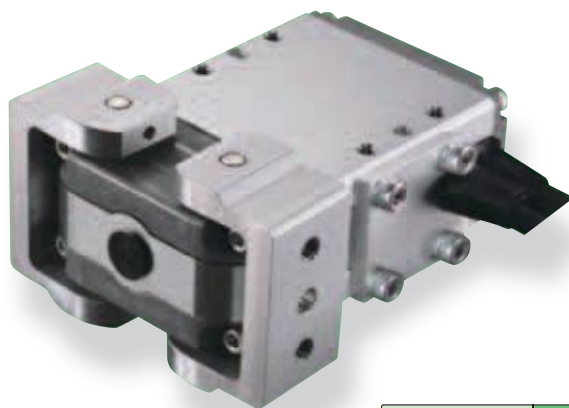

Technical References P. A-5

■ Grip Force Arrangement
 Through push operation the grip force (push force) can be arranged freely within the range of 20%~70% of current limit value of the controller.

* Grip force noted in the figure below is the sum of the grip force of two fingers.

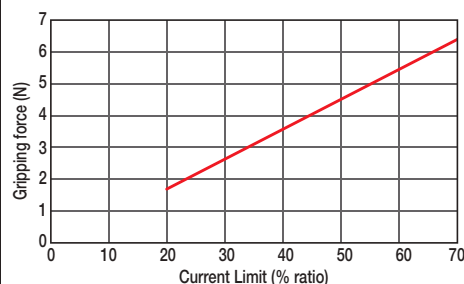

* The value of the gripping (pushing) in the graph is only reference. Please note that there is a maximum variation of about 15%.

* Please note when gripping (pushing) is performed the speed will be fixed at 5 degrees/sec.

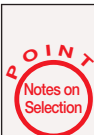

- (1) The max. open/close speed represents one side operating speed.
- (2) The max. grip force will be the sum of the two fingers grip force when the distance for grip point and over hang is 0. The actual work part weight which can be transported depends on the friction constant between finger and work part material, and the form; typically it is 1/10 ~ 1/20 or less than gripping force. (See page A-77 for details.)
- (3) The rated acceleration at transportation is 0.3G.
- (4) Please note that the product has no splash-proof function.

Actuator Specifications

Lead and Load Capacity

Model	Deceleration ratio	Max. Grip Force (N)	Stroke (degrees)
RCP2W-GRLS-I-20P-30-180-①-②-③	30	6.4	180 (One side 90)

Legend ① Compatible controller ② Cable length ③ Options

Stroke and Maximum Open/Close Speed

Deceleration ratio	Stroke	180 (degrees)
	30	600

(Unit: degrees/s)

Cable List

Type	Cable Symbol
Standard (Robot Cables)	P (1m)
	S (3m)
	M (5m)
Special Lengths	X06 (6m) ~ X10 (10m)
	X11 (11m) ~ X15 (15m)
	X16 (16m) ~ X20 (20m)

* The standard cable is the motor-encoder integrated robot cable.

* See page A-39 for cables for maintenance.

Actuator Specifications

Item	Description
Drive System	Worm gear + Helical gear
Positioning Repeatability	±0.01mm
Backlash	1 degree or less for one side (stressed by spring on the side which is opened always)
Lost Motion	0.1 mm or less one side
Guide	-
Statically Allowable Load Moment	-
Weight	0.2kg
Protection Structure	IP50
Ambient Operating Temp./Humidity	0~40°C, 85%RH or less (Non-condensing)

Option List

Name	Option Code	See Page
Reversed-home	NM	A-33
Flange Bracket	FB	26
Shaft Bracket	SB	36

Dimensions

CAD drawings can be downloaded from IAI website. www.robocylinder.de

For Special Order P. A-9



- * Open side of slider will be home position.
- *1 A motor-encoder cable is connected here. See page A-39 for details on cables.

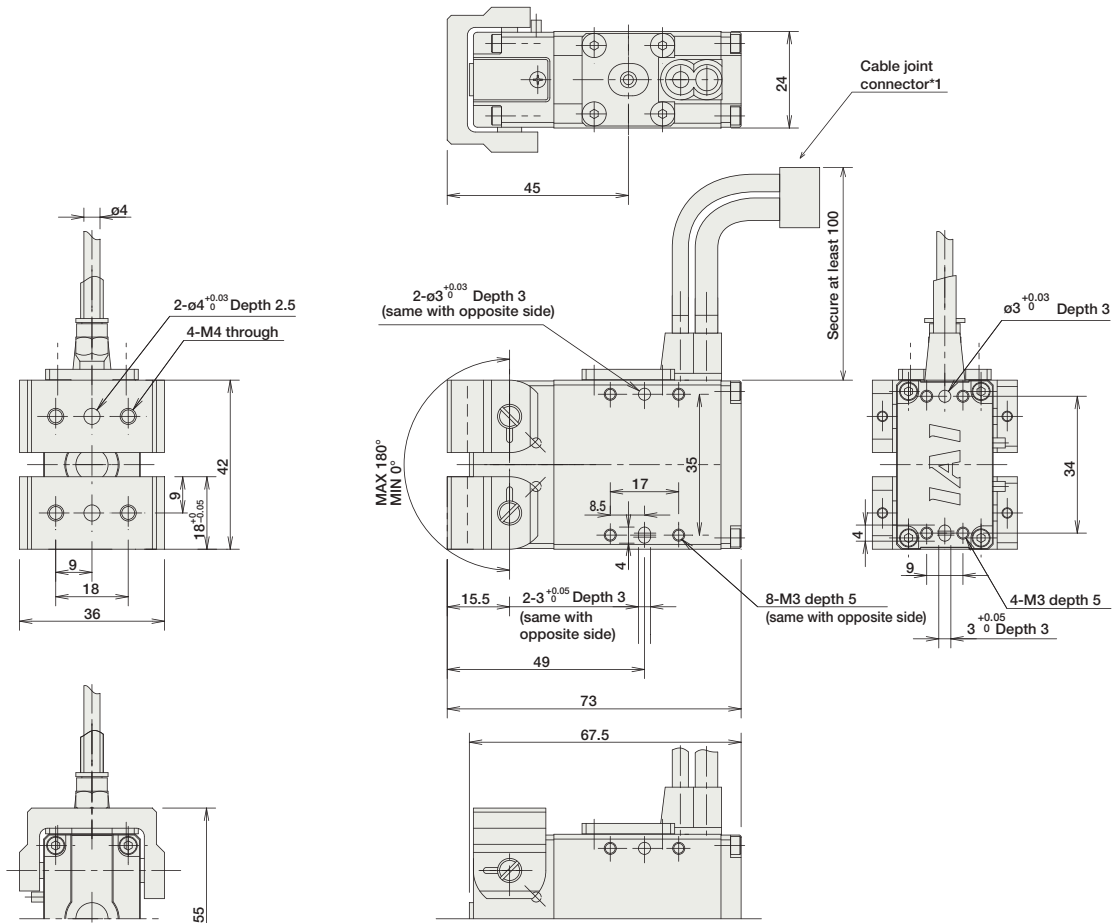

Weight (kg) 0.2

Compatible Controllers

The RCP2W series actuators can operate with the controllers below. Select the controller according to your usage.

Name	External View	Model	Description	Max. Positioning Points	Input Voltage	Power Supply Capacity	See Page
Solenoid Valve Type		PMEC-C-20PI-NP-2-2	Easy-to-use controller, even for beginners.	3 points	AC115V AC230V	See P481	→ P477
		PSEP-C-20PI-NP-2-0	Operable with same signal as solenoid valve. Supports both single and double solenoid types. No homing necessary with simple absolute type.				→ P487
Splash-Proof Solenoid Valve Type		PSEP-CW-20PI-NP-2-0					
Positioner Type		PCON-C-20PI-NP-2-0	Positioning possible for up to 512 points	512 points	DC24V	2A max.	
Safety Category Compliant Positioner Type		PCON-CG-20PI-NP-2-0					
Pulse Train Input Type (Differential Line Driver)		PCON-PL-20PI-NP-2-0	Differential line driver support Pulse Train Input Type	(-)	DC24V	2A max.	→ P525
Pulse Train Input Type (Open Collector)		PCON-PO-20PI-NP-2-0	Open Collector Pulse Train Input Type				
Serial Communication Type		PCON-SE-20PI-N-0-0	Dedicated to serial communication	64 points			
Field Network Type		RPCON-20P	Dedicated to field network	768 points			→ P503
Program Control Type		PSEL-C-1-20PI-NP-2-0	Programmed operation is possible Can operate up to 2 axes	1500 points			→ P557

* This is for the single-axis PSEL.

- Slider Type
- Mini
- Standard
- Controllers Integrated
- Rod Type
- Mini
- Standard
- Controllers Integrated
- Table/Arm /Flat Type
- Mini
- Standard
- Gripper/ Rotary Type
- Linear Motor Type
- Cleanroom Type
- Splash-Proof
- Controllers
- PMEC /AMEC
- PSEP /ASEP
- ROBO NET
- ERC2
- PCON
- ACON
- SCON
- PSEL
- ASEL
- SSEL
- XSEL
- Pulse Motor
- Servo Motor (24V)
- Servo Motor (230V)
- Linear Motor

PCON

Models C / CA / CG / CF / CFA / CY / PL / PO / SE

Position Controllers
For RCP3/RCP2 series



List of models

These are the position controllers that can be used with the RCP3/RCP2 series actuators. Our line-up has 6 types, which are compatible with various control systems.

Type	C / CA	CG	CF / CFA	CY	PL / PO	SE
Name	Positioner type	Conforming to safety category compatible type	High-thrust motor compatible type	Solenoid valve type	Pulse train control type	Serial communication type
External View						
Description	Positioner capable of a maximum of 512 points positioning (*1)	Conforming to type C safety category specifications (*1)	Dedicated controller for RCP2 high-speed type / high-thrust type / waterproof type (*1)	Can be operated using the same control as the air cylinder type	For pulse train control	For Serial communication
Position points	512 points (*2)	512 points (*2)	512 points (*2)	3 points	—	64 points

(*1) Network connection specifications are designated by the I/O type symbols for the model.
(*2) Besides positioning mode PCON-C/CG/CF can be operated in teaching and solenoid valve mode, PCON-CA/CFA additionally in pulse-train mode.

Model

PCON — [] — [] — **I** — [] — [] — **0** — [] — []

Series Type Motor Encoder I/O Type I/O cable length Power/Voltage Simple absolute unit High accel. model/DIN rail mounting

C Positioner Type	20P 20 frame pulse motor	I Incremental	NP PIO NPN	NP PIO NPN	Blank Not used	Blank Standard
CA High-function Positioner Type	20SP 20 frame pulse motor motor-compatible (*)					
CG Safety-compliant type	28P 28 frame pulse motor-compatible	DV DeviceNet	PN PIO PNP (standard)	PLP Pulse-train input PNP (*)	ABU Used w/ absolute battery unit	DIN DIN rail mounting (**)
CF High thrust motor compatible type	28SP 28 frame pulse motor motor-compatible (**)					
CFA High-function High thrust motor compatible Type	35P 35 frame pulse motor-compatible	CC CC-Link	PR ProfiBus	DV DeviceNet	0 DC24V	0 No cable (*)
CY Solenoid Valve Type	42P 42 frame pulse motor-compatible					
SE Serial Communication Type	56P 56 frame pulse motor-compatible	PT ProfiNet	ML MechatroLink	EC EtherCAT	3 3m	5 5m
PL Pulse Train Control Type (differential line driver model)	60P 60 frame pulse motor-compatible					
PO Pulse Train Control Type (open collector model)	86P 86 frame pulse motor-compatible	CN CompoNet	EC EtherCAT	EP EtherNet/IP	2 2m (standard)	3 3m
		EP EtherNet/IP	SC Sercos III (**)	N No I/O (SE type only)	5 5m	

* If connecting to RCP2-RA2□ model with high-load motor, the motor type is 20SP.
** If connecting to RCP2-RA3C/RGD3C, the motor type is 28SP.

Only available for PCON-CA/CFA

Planned industrial ethernet interface

The network models (DV...SC) support C/CA/CG/CF/CFA types only. When selecting type SE (serial communication), the standard I/O is "N" (no I/O).

Only for PCON-C/CG/CF/CY/PL/PO/SE: If connecting to RCP3-SA4/SA5/SA6, RCP2/RCP2CR-SA5/SA6, specify "H", for high-acceleration type model. ** Only available for PCON-CA/CFA.

System configuration

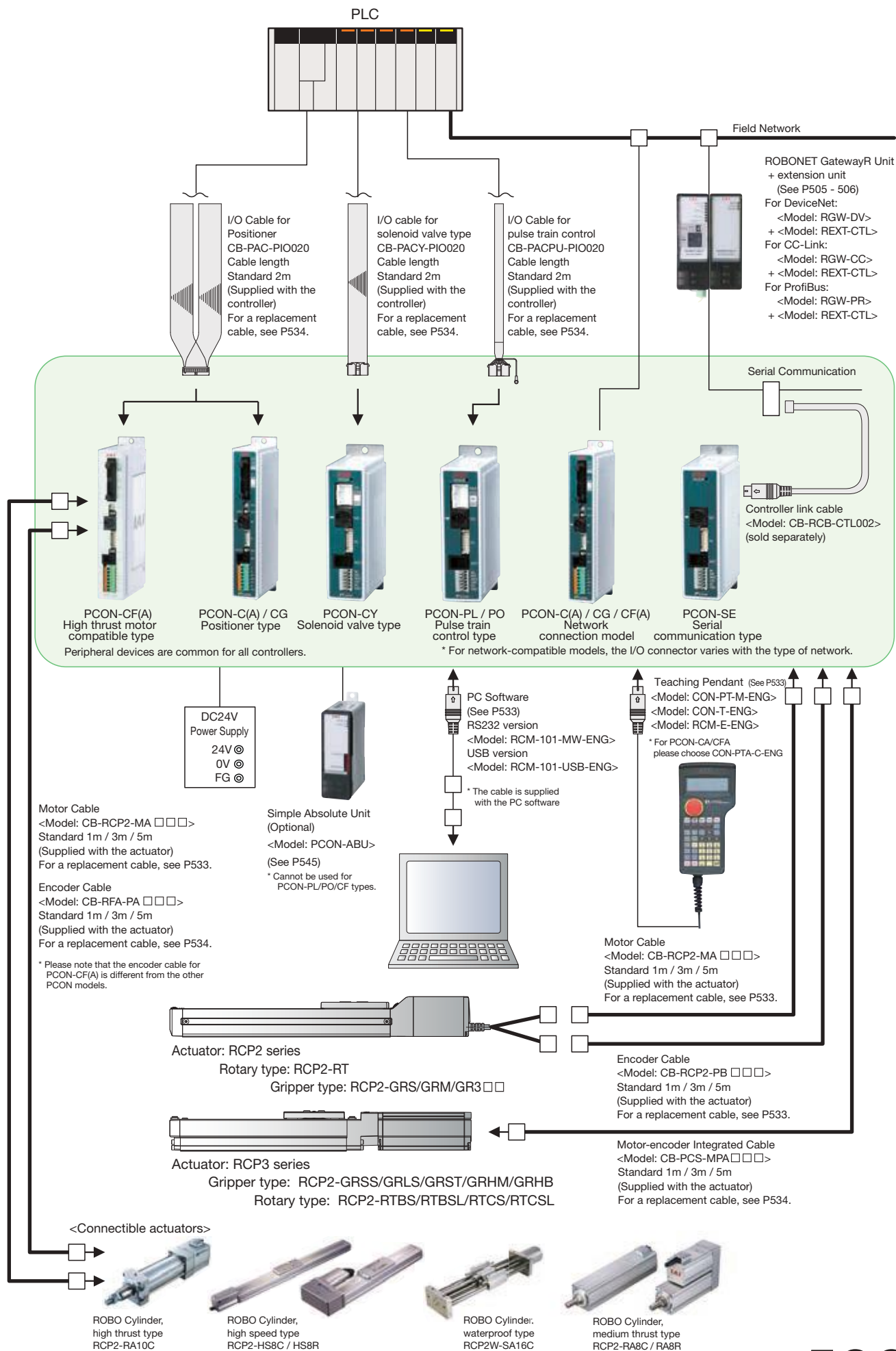

- Slider Type
- Mini
- Standard
- Controllers Integrated
- Pod Type
- Mini
- Standard
- Controllers Integrated
- Table/Arm /FlatType
- Mini
- Standard
- Gripper/ Rotary Type
- Linear Motor Type
- Cleanroom Type
- Splash-Proof
- Controllers
- PMEC /AMEC
- PSEP /ASEP
- ROBO NET
- ERC2
- PCON
- ACON
- SCON
- PSEL
- ASEL
- SSEL
- XSEL
- Pulse Motor
- Servo Motor (24V)
- Servo Motor (230V)
- Linear Motor

I/O Specifications

Input section External input specifications

Item	Specifications
Input voltage	DC24V +/-10%
Input current	5mA/circuit
Leak current	1mA max./point
Isolation method	Photocoupler

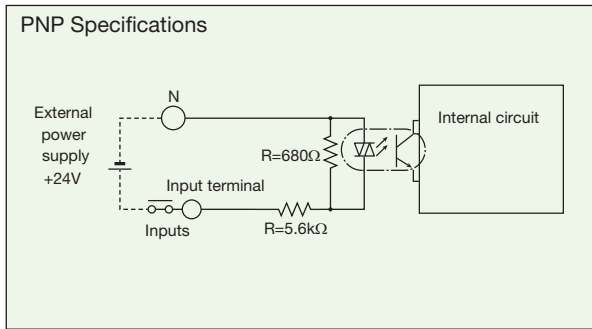
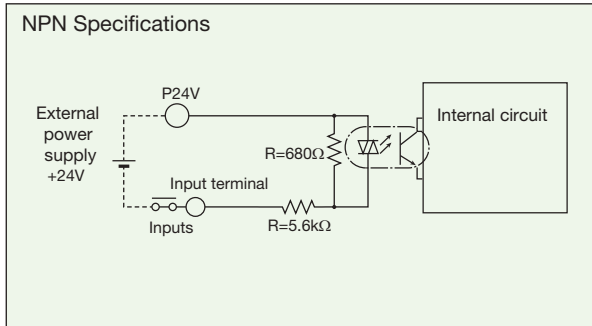

Output section External output specifications

Item	Specifications
Load Voltage	DC24V
Max. load current	50mA/point
Remaining voltage	2V or less
Isolation method	Photocoupler

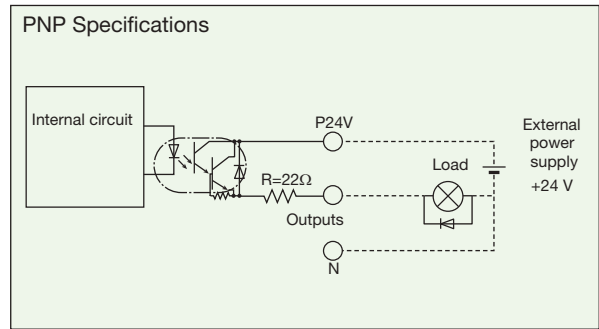
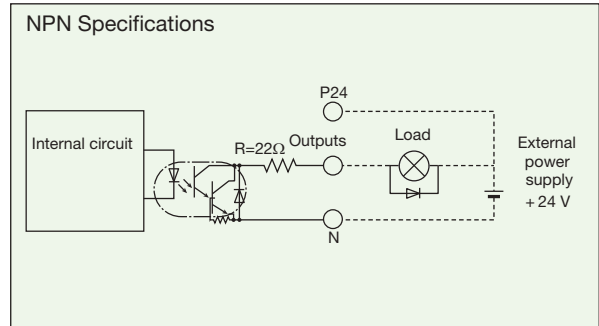

I/O Specifications

The 4 types of controllers (C(A)/CG/CF(A), CY, PL/PO, and SE) are classified by their respective I/O specifications. In addition, with the positioner type and solenoid valve type, the I/O signal details can be changed via the controller settings. As a result, a number of functions can be used.

Control Function by Type

Type	C(A)/CG/CF(A)	CY	PL/PO	SE	Features
Name	Positioner type	Solenoid valve type	Pulse in-line control type	Serial communication type	
Positioner mode	<input type="radio"/>	-	-	<input type="radio"/> (*1)	This is the basic operating mode, in which the user designates position numbers and inputs start signals.
Teaching mode	<input type="radio"/>	-	-	<input type="radio"/> (*1)	In this mode, the slider (rod) moves based on an external signal, and the stopped positions can be registered as position data.
Solenoid valve mode	<input type="radio"/>	<input type="radio"/>	-	<input type="radio"/> (*1)	The actuator can be moved simply by ON/OFF of position signals. This mode supports the same control signals you are already familiar with on solenoid valves of air cylinders.
Pulse train mode	<input type="radio"/> (*2)	-	<input type="radio"/>	-	In this mode, you can operate the actuator freely using pulse trains without inputting position data.
Network compatible	<input type="radio"/> (*3)	-	-	<input type="radio"/> (*4)	The controller can be connected to a DeviceNet or CC-Link network.

*1 Operates using network communications or serial communications.
 *2 Only high-function types PCON-CA/CFA can be operated in pulse-train mode.
 *3 Can make a direct connection to a field network with the network specifications.
 *4 Can be connected to a field network using a gateway unit.

Explanation of I/O Signal Functions

The table below explains the functions allocated to the controller's I/O signal.

Since the signals that can be used vary depending on the controller type and settings, check the signal table for each controller to confirm the available functions.

Signal Function Description

Classification	Signal abbreviations	Signal	Function description
Input	CSTR	PTP strobe signal (start signal)	Input this signal to cause the actuator to start moving to the position set by the command position number signal.
	PC1 to PC256	Command position number signal	This signal is used to input a target position number (binary input).
	BKRL	Brake forced release signal	This signal forcibly releases the brake.
	RMOD	Running mode switching signal	This signal can switch the running mode when the MODE switch on the controller is set to AUTO. (AUTO when this signal is OFF, or MANU when the signal is ON)
	*STP	Pause signal	Turning this signal OFF causes the moving actuator to decelerate to a stop. The actuator will resume the remaining movement if the signal is turned ON during the pause.
	RES	Reset signal	Turning this signal ON resets the alarms that are present. If this signal is turned ON while the actuator is paused (*STP is OFF), the remaining movement can be cancelled.
	SON	Servo ON signal	The servo remains on while this signal is ON, or off while the signal is OFF.
	HOME	Home return signal	Turning this signal ON performs home-return operation.
	MODE	Teaching mode signal	Turning this signal ON switches the controller to the teaching mode. (provided that CSTR, JOG+ and JOG- are all OFF and the actuator is not moving).
	JISL	JOG/INCHING switching signal	When the main signal is off, the JOG operation will be conducted for JOG+ and JOG-. When the signal is on, the unit will do the inching operation for JOG+ and JOG-.
	JOG+, JOG-	JOG signal	When the JISL signal is off and the JOG +/- signal turns on, the unit will jog in the + (positive) direction when the JOG + turns on and the - (negative) direction when the JOG - turns on. During the JOG operation, the unit slows to a stop when the JOG +/- signal turns off.
	PWRT	Teaching signal	In the teaching mode, specify a desired position number and then turn this signal ON for at least 20ms to write the current position to the specified position number.
	ST0 to ST6	Start position command	Turning this signal ON in the solenoid valve mode causes the actuator to move to the specified position. (Start signal is not required)
	TL	Torque limit selection signal	While this signal is ON, torque is limited by the value set by a parameter. The TLR signal turns on if torque has reached the specified value.
DCLR	Deviation counter clear signal	The position deviation counter is continuously cleared while this signal is ON.	
Output	PEND/INP	In position signal	This signal turns ON when the actuator has entered the positioning band after movement. If the actuator has exceeded the positioning band, PEND does not turn OFF, but INP does. PEND and INP can be swapped within parameters.
	PM1 to PM256	Positioning complete signal	This signal is used to output the position number achieved at the completion of positioning (binary output)
	HEND	Home return completion signal	This signal turns ON upon completion of home return.
	ZONE1	Zone signal	This signal turns ON when the current actuator position has entered the range specified by the parameters.
	PZONE	Position zone signal	Turns ON when the actuator moves into a position within the range of the target position data that was set. PZONE can be used together with ZONE1, but PZONE is valid only during movement to a specified position.
	RMDS	Running mode status signal	This outputs the operation mode status.
	*ALM	Controller alarm status signal	This signal remains ON while the controller is not in the alarm condition, and turns OFF when an alarm has occurred.
	MOVE	Moving signal	Turns ON while the actuator is moving (home return), including when there is push force.
	SV	Servo ON status signal	This signal turns ON when servo is ON.
	*EMGS	Emergency stop status signal	This signal remains ON while the controller is not in the emergency stop mode, and turns OFF once an emergency stop has been actuated.
	MODES	Mode status signal	The mode signal input turns it ON when it goes into teaching mode. It turns OFF when it goes into normal mode.
	WEND	Writing complete signal	This signal remains OFF after the controller has switched to the teaching mode. It turns ON upon completion of data write using the PWRT signal. If the PWRT signal is turned Off, this signal also turns OFF.
	PE0 to PE6	Current position number signal	This signal turns ON after the controller has completed moving to the target position in the solenoid valve mode.
	TLR	Torque limiting signal	This signal turns ON once the motor torque has reached the specified value in a condition where torque is being limited by the TL signal.
	LSO to LS2	Limit switch output signal	Each signal turns ON when the current actuator position has entered the positioning band before or after the target position. If the actuator has already completed home return, these signals are output even before a movement command is issued or while the servo is OFF.
	LOAD	Load output determination status signal	This signal turns ON once the motor torque has reached the specified value. (*PCON-CF dedicated signal)
TRQS	Torque level status signal	Turns ON when the motor current reaches the threshold. (*PCON-CF dedicated signal)	

(Note) Signals with asterisks (*) are normally ON and OFF during operation.

Slider Type

Mini

Standard

Controllers Integrated

Rod Type

Mini

Standard

Controllers Integrated

Table/Arm /FlatType

Mini

Standard

Gripper/ Rotary Type

Linear Motor Type

Cleanroom Type

Splash-Proof

Controllers

PMEC /AMEC

PSEP /ASEP

ROBO NET

ERC2

PCON

ACON

SCON

PSEL

ASEL

SSEL

XSEL

Pulse Motor

Servo Motor (24V)

Servo Motor (230V)

Linear Motor

I/O Signal table

Positioner types (PCON-C / CA / CG / CF / CFA)

Pin No.	Classification		Parameters (select PIO pattern)					
			0	1	2	3	4	5
			Positioning mode	Teaching mode	256-point mode	512-point mode	Solenoid Valve Mode 1	Solenoid Valve Mode 2
			Positioning Points	64 points	64 points	256 points	512 points	7 points
		Zone signal	○	—	—	—	○	○
		P-zone signal	○	○	○	—	○	○
1A	24V		P24					
2A	24V		P24					
3A	—		NC					
4A	—		NC					
5A	Input	IN0	PC1	PC1	PC1	PC1	ST0	ST0
6A		IN1	PC2	PC2	PC2	PC2	ST1	ST1 (JOG+)
7A		IN2	PC4	PC4	PC4	PC4	ST2	ST2 (-)
8A		IN3	PC8	PC8	PC8	PC8	ST3	—
9A		IN4	PC16	PC16	PC16	PC16	ST4	—
10A		IN5	PC32	PC32	PC32	PC32	ST5	—
11A		IN6	—	MODE	PC64	PC64	ST6	—
12A		IN7	—	JISL	PC128	PC128	—	—
13A		IN8	—	JOG+	—	PC256	—	—
14A		IN9	BKRL	JOG-	BKRL	BKRL	BKRL	BKRL
15A		IN10	RMOD	RMOD	RMOD	RMOD	RMOD	RMOD
16A		IN11	HOME	HOME	HOME	HOME	HOME	—
17A		IN12	*STP	*STP	*STP	*STP	*STP	—
18A		IN13	CSTR	CSTR/PWRT	CSTR	CSTR	—	—
19A		IN14	RES	RES	RES	RES	RES	RES
20A	IN15	SON	SON	SON	SON	SON	SON	
1B	Output	OUT0	PM1	PM1	PM1	PM1	PE0	LS0
2B		OUT1	PM2	PM2	PM2	PM2	PE1	LS1 (TRQS)
3B		OUT2	PM4	PM4	PM4	PM4	PE2	LS2 (-)
4B		OUT3	PM8	PM8	PM8	PM8	PE3	—
5B		OUT4	PM16	PM16	PM16	PM16	PE4	—
6B		OUT5	PM32	PM32	PM32	PM32	PE5	—
7B		OUT6	MOVE	MOVE	PM64	PM64	PE6	—
8B		OUT7	ZONE1	MODES	PM128	PM128	ZONE1	ZONE1
9B		OUT8	PZONE	PZONE	PZONE	PM256	PZONE	PZONE
10B		OUT9	RMDS	RMDS	RMDS	RMDS	RMDS	RMDS
11B		OUT10	HEND	HEND	HEND	HEND	HEND	HEND
12B		OUT11	PEND	PEND/WEND	PEND	PEND	PEND	—
13B		OUT12	SV	SV	SV	SV	SV	SV
14B		OUT13	* EMGS	* EMGS	* EMGS	* EMGS	* EMGS	* EMGS
15B		OUT14	* ALM	* ALM	* ALM	* ALM	* ALM	* ALM
16B	OUT15	LOAD/TRQS	—	LOAD/TRQS	LOAD/TRQS	LOAD/TRQS	—	
17B	—		NC					
18B	—		NC					
19B	0V		N					
20B	0V		N					

(Note) The names of signals above inside () are functions before the unit returns home.
 (Note) Signals with asterisks (*) are normally ON, and OFF during operation.

Solenoid valve type (PCON-CY)

Pin No.	Classification		Parameters (select PIO pattern)	
			0	1
			Solenoid valve mode 0	Solenoid valve mode 1
			Positioning Points	3 points
		Zone signal	—	—
		P-zone signal	—	○
1	24V			
2	0V			
3	Input	IN0	ST0	ST0
4		IN1	ST1 (JOG+)	ST1 (JOG+)
5		IN2	ST2 (RES)	ST2 (RES)
6		IN3	SON	SON
7		OUT0	LS0	PE0
8	Output	OUT1	LS1 (TRQS)	PE1 (TRQS)
9		OUT2	LS2 (-)	PE2 (-)
10		OUT3	SV	PZONE
11		OUT4	HEND	HEND
12		OUT5	* ALM	* ALM

(Note) The names of signals above inside () are functions before the unit returns home.
 (Note) Signals with asterisks (*) are normally ON, and OFF during operation.

Pulse Train Type (PCON-PL/PO)

Pin No.	Classification		Parameters (select PIO pattern)	
			0	1
			Standard mode	Push mode
			Positioning Points	—
		Zone signal	—	—
		P-zone signal	—	—
1	24V			
2	0V			
3	Input	IN0	SON	SON
4		IN1	TL	TL
5		IN2	HOME	HOME
6		IN3	RES	RES / DCLR
7		OUT0	SV	SV
8	Output	OUT1	INP	INP / TLR
9		OUT2	HEND	HEND
10		OUT3	* ALM	* ALM
11	Input		* PP	* PP
12			PP	PP
13			* NP	* NP
14			NP	NP

(Note) Signals with asterisks (*) are normally ON, and OFF during operation.

Pulse train input type wiring diagram

■ Differential Receiver Method (PCON-PL)

Max. input pulse frequency : Max. 200 kpps
 Cable Length : Max. 10m

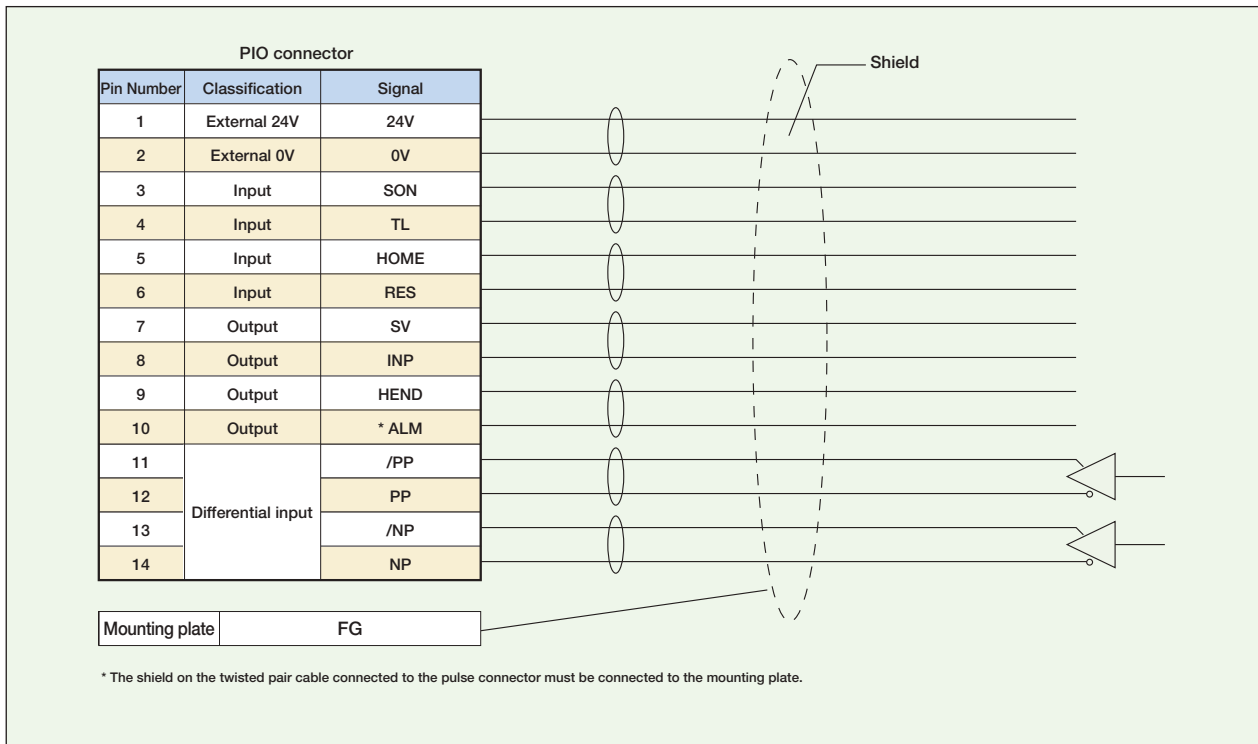

■ Open Collector Method (PCON-PO)

Max. input pulse frequency : Max. 60 kpps
 Cable Length : Max. 2m

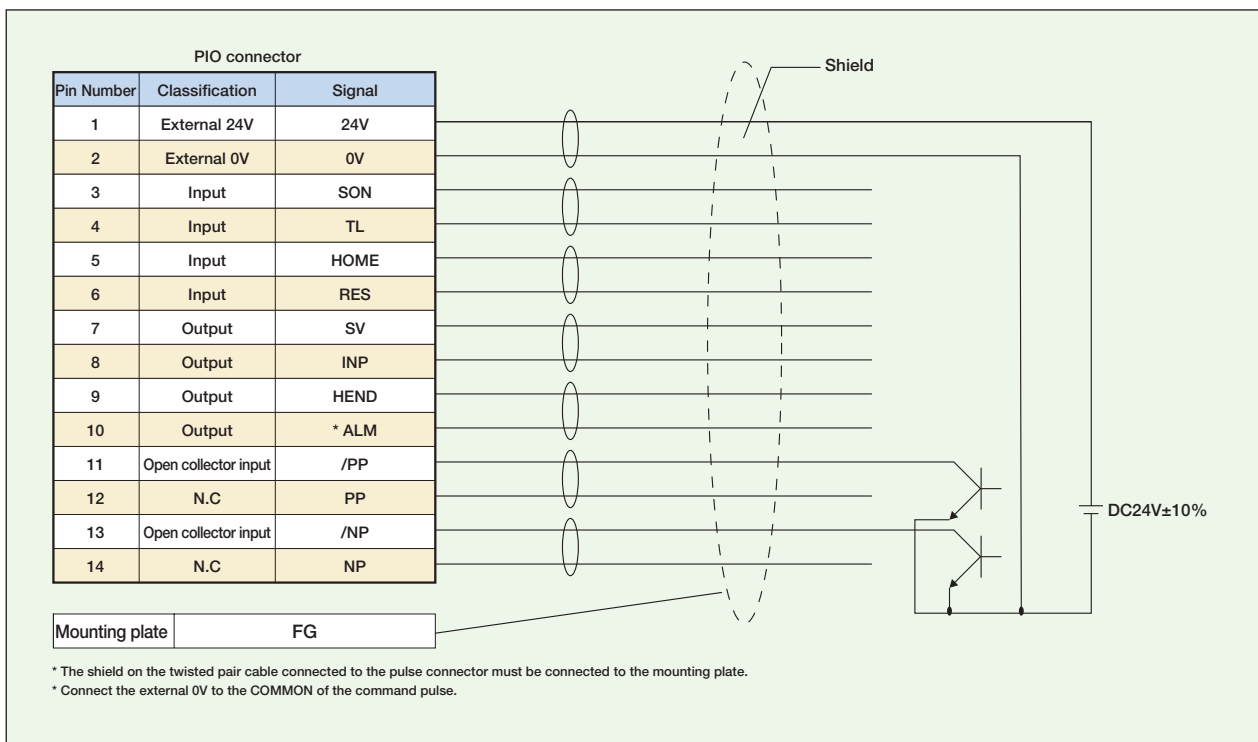

- Slider Type
- Mini
- Standard
- Controllers Integrated
- Rod Type
- Mini
- Standard
- Controllers Integrated
- Table/Arm /FlatType
- Mini
- Standard
- Gripper/ Rotary Type
- Linear Motor Type
- Cleanroom Type
- Splash-Proof
- Controllers
- PMEC /AMEC
- PSEP /ASEP
- ROBO NET
- ERC2
- PCON
- ACON
- SCON
- PSEL
- ASEL
- SSEL
- XSEL
- Pulse Motor
- Servo Motor (24V)
- Servo Motor (230V)
- Linear Motor

Command Pulse Input State

Command pulse train state		Input terminal	During forward operation	During reversed operation		
Negative logic	Forward pulse train	PP•/PP				
	Reversed pulse train	NP•/NP				
	The forward pulse train causes the motor to rotate forward, and the reverse pulse train causes the motor to rotate in reverse.					
	Pulse train	PP•/PP				
	Symbols	NP•/NP	Low	High		
	The command pulse is used for the amount of motor rotation, and the command symbol is used for rotational direction.					
	A/B phase pulse train	PP•/PP				
		NP•/NP				
		An A/B phase pulse with a 90° phase difference (multiplier is 4) is used to generate commands for the amount of rotation and rotational direction.				
Positive logic	Forward pulse train	PP•/PP				
	Reversed pulse train	NP•/NP				
	Pulse train	PP•/PP				
	Symbols	NP•/NP	High	Low		
	A/B phase pulse train	PP•/PP				
		NP•/NP				

Table of specifications

Item	Specifications						
	CF / CFA	C / CA	CG	CY	PL	PO	SE
Controller type	CF / CFA	C / CA	CG	CY	PL	PO	SE
Connected actuator (*1)	RCP2-RA8C (R) RCP2-RA10C RCP2-HS8C (R) RCP2W-SA16C	RCP3 / RCP2 series actuator (Note 1)					
Number of control axes	1-axis						
Operating method	Positioner type			Solenoid valve type	Pulse train input type		Serial communication type
Positioning Points	512 points			3 points	-		64 points
Backup memory	EEPROM						
I/O connector	40-pin connector			12-pin connector	40-pin connector		None
Number of I/O	16 input points/16 output points			4 input points/6 output points	4 input points/4 output points		None
I/O power	External supply DC24V±10%						
Serial Communication	RS485 1ch						
Peripheral device communication cable	CB-PAC-PIO □□□			CB-PACY-PIO □□□	CB-PACPU-PIO □□□		CB-RCB-CTL002
Command pulse train input method	-			Differential line driver		Open collector	
Max. input pulse frequency (Note 2)	-			Max. 200 kpps		Max. 60 kpps	
Position detection method	Incremental encoder						
Drive-source cutoff relay at emergency stop	Integrated			External			
Forced release of electromagnetic brake	Brake release switch ON/OFF			ON/OFF terminal signal inside the power terminal for brake release			
Input Supply Voltage	DC 24 V ± 10%						
Power Supply Capacity	Max. 6A (*2)	2.2A max.					
Dielectric strength voltage	DC500V 1MΩ						
Vibration resistance	XYZ directions			10 to 57Hz, One side amplitude: 0.035mm (continuous), 0.075mm (intermittent) 58 to 150Hz, 4.9m/s ² (continuous), 9.8m/s ² (intermittent)			
Ambient operating temperature	0 ~ 40°C						
Ambient operating humidity	10 - 95% (non-condensing)						
Ambient operating atmosphere	Without corrosion gases						
Protection class	IP20						
Weight	Approx. 320g	Approx. 300g			Approx. 130g		

(Note 1) The medium-thrust type (RA8C/RA8R), high-thrust type (RA10C), high-speed type (HS8C/HS8R) and waterproof type (RCP2W-SA16) cannot be operated.
 (Note 2) With the open collector specification, keep the maximum input frequency to 60 kpps or below to prevent malfunction. For applications exceeding 60kpps, use the differential line driver.
 (*1) RCP2-RA8C/RA8R/RA10C/HS8C/HS8R and RCP2W-SA16C can only operate with PCON-CF(A).
 Other RCP2 / RCP3 Series actuators can be operated with C(A) / CG / CY / PL / PO / SE.
 (*2) Inrush current peak: 10A

External Dimensions

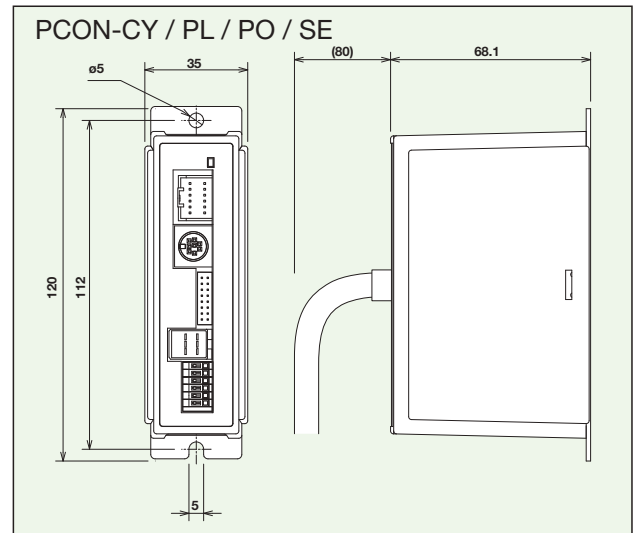
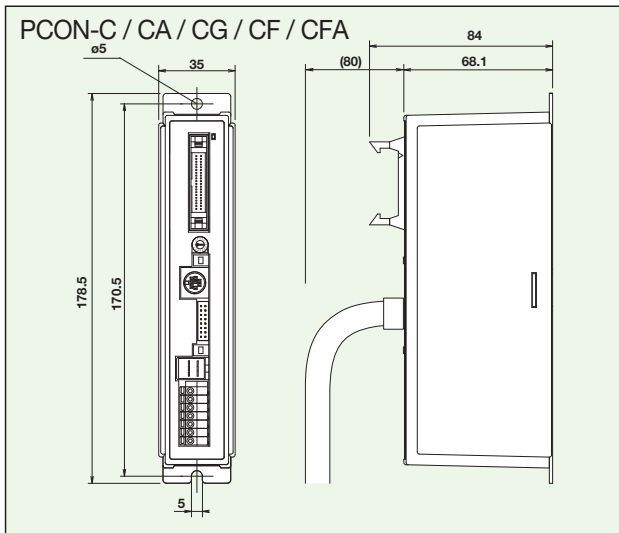

Name of Each Part

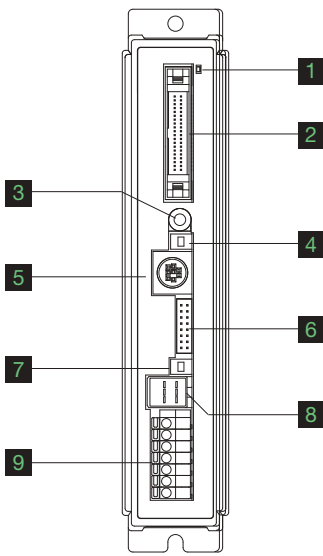

C / CA / CG / CF / CFA Type

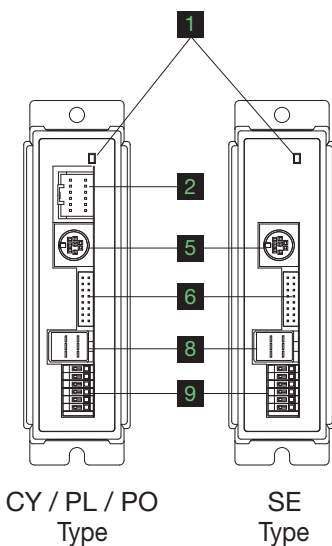

CY / PL / PO Type

SE Type

* PIO connectors are:
CY: 12 pin
PL/PO: 14 pin

1 LED display

These LED colors indicate the condition of the controller.

Lit (green) Servo ON Lit (red) Alarm activated Unlit Servo OFF Blinking (green) Automatic servo-off Emergency stop

2 PIO connector

Connects a cable for communicating with a PLC or other external equipment.

3 Address-setting rotary switch

This switch sets the addresses for controllers used when the unit is linked with other controllers.

4 Mode switch

Switches between manual teaching operations (MANU) and automatic operations (AUTO).

Operation details

MANU	I/O commands are not accepted. Data can be written from a teaching pendant or PC.
AUTO	I/O commands are valid, while operations from a teaching pendant or PC are not accepted. However, monitoring is possible.

5 SIO connector

Connects a teaching pendant, PC cable, controller, or gateway unit to a controller.

Operation details

Pin No.	Signal	Name	Remarks
1	SGA	Positive side, RS485 differential signal	
2	SGB	Negative side, RS485 differential signal	
3	5V	+5V output	For RS232/485 conversion
4	ENBL	Enable signal	
5	EMGA	EMG line connection to external equipment	
6	24V	24-V power for T/P	For T/P
7	0V	GND	
8	EMGB	EMG line connection to external equipment	
9	0V	EMG line connection to external equipment ground	

6 Encoder brake connector

Connects the encoder/brake cable for the actuator.

7 Brake release switch

This switch forces the brake to release.

8 Motor connector

Connects the motor cable for the actuator.

9 Power terminal block

Main power for controller(s), emergency stop

C / CA / CG / CF / CFA type

Terminal number	Signal	Name
7	S1	External drive-source cutoff for TP_
6	S2	EMG terminal
5	MPI	Motor drive-source cutoff terminal
4	MPO	Motor drive-source cutoff terminal
3	24V	Positive side of the 24-V power supply
2	0V	Negative side of the 24-V power supply
1	EMG	EMG signal (application of 24 V)

CY / PL / PO / SE type

Terminal number	Signal	Name
6	BK	BK release
5	MPI	Motor drive-source cutoff terminal
4	MPO	Motor drive-source cutoff terminal
3	24V	Positive side of the 24-V power supply
2	0V	Negative side of the 24-V power supply
1	EMG	EMG signal (application of 24 V)

Option

Teaching Pendant

■ Features This is a teaching device that provides information on functions such as the position input, test runs, and monitoring.

■ Model **CON-PT-M-ENG** (Touch panel teaching pendant)

CON-T-ENG (Standard type)

RCM-E (Simple teaching pendant)

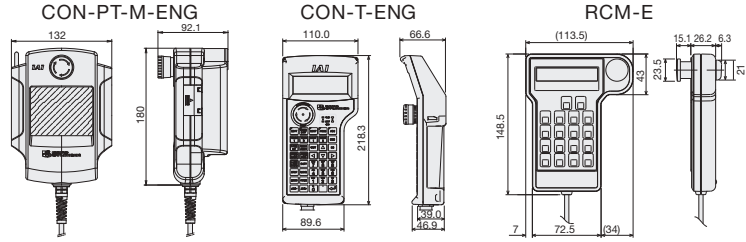

■ Configuration



Note:

The version of RCM-E that can be used with ROBONET is 2.08 or later.

5m



■ CON-T-ENG Options

• Wall-mounting hook

• Strap

Model HK-1

Model STR-1

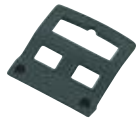

■ Specifications

Item	CON-PT-M-ENG	CON-T-ENG	RCM-E
Data input	○	○	○
Actuator motion	○	○	○
Ambient Operating temp/humidity	Temp: 0~40°C; Humidity: 85% RH or below		
Ambient Operating atmosphere	No corrosive gases. Especially no dust.		
Protection class	IP40	IP54	-
Weight	Approx. 750g	Approx. 400g	Approx. 400g
Cable length	5m		
Display	3-color LED touch panel with backlight	20 char. × 4 lines LCD display	16 char. × 2 lines LCD display

For PCON-CA/CFA please choose more functional and lighter teaching pendant CON-PTA-C-ENG with 16-bit color LED touch panel (IP40).

PC Software (Windows Only)

■ Features A startup support software for inputting positions, performing test runs, and monitoring. With enhancements for adjustment functions, the startup time is shortened.

■ Model **RCM-101-MW-ENG** (External device communications cable + RS232 conversion unit)

■ Configuration



RS232 adapter RCB-CV-MW

0.3m

5m

External device communications cable CB-RCA-SIO050



■ Model **RCM-101-USB-ENG** (External device communications cable + USB adapter + USB cable)

■ Configuration



USB adapter RCB-CV-USB

3m

5m

USB cable CB-SEL-USB030

External device communications cable CB-RCA-SIO050



Spare Parts

When you need spare parts after purchasing the product, such as when replacing a cable, refer to the list of models below.

Motor Cable for RCP2

Model **CB-RCP2-MA** * The standard cable for the motor cable is the robot cable.

* Enter the cable length (L) into . Compatible to a maximum of 20 meters. Ex.: 080 = 8 m

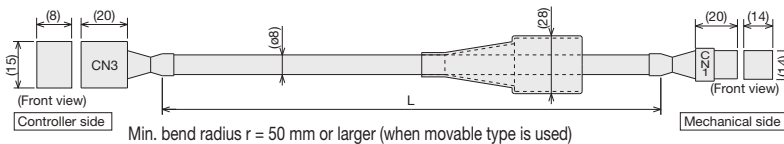

Cable color	CN3		M cable		CN1	
	Standard Cable	Robot Cable	Signal	Pin No.	Signal	Pin No.
Gray	VMM	A2	1	A	w	11 e
White	B	A3	2	VMM	Gray	SLP-06V (JST)
Yellow	A	B1	3	A	Orange	
Pink	VMM	B2	4	B	Yellow (Green)	
Yellow (Green)	B	B3	5	VMM	Pink	
			6	B	White	

Encoder Cable / Encoder Robot Cable for RCP2

Model **CB-RCP2-PB** / **CB-RCP2-PB** - **RB** * The standard cable for the encoder cable is the normal cable. A robot cable can be specified as an option.

* Enter the cable length (L) into . Compatible to a maximum of 20 meters. Ex.: 080 = 8 m

Min. bend radius r = 50 mm or larger (when movable type is used)
* Only robot cable is to be used in a cable track.

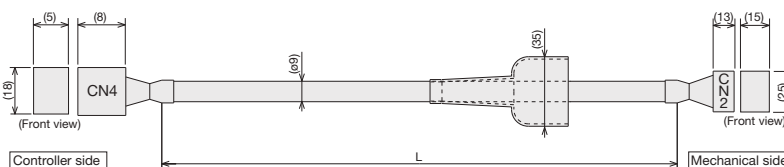

Cable color	CN4		Signal	Pin No.	Cable color	CN2	
	Standard Cable	Robot Cable				Signal	Pin No.
Blue (Red 1)	Orange (Black 2)	L S +	16	1	E N A	Brown	Light Gray (Red 1)
White	Orange (Red 2)	L S -	15	2	E N A	Green	Light Gray (Red 1)
Red	Orange (Black 1)	B K +	14	3	E N B	Purple	White (Black 1)
Gray	Orange (Red 1)	B K -	13	4	E N B	Pink	White (Red 1)
Brown	Light Gray (Blue 1)	E N A	12	5			
Green	Light Gray (Red 1)	E N A	11	6			
Purple	White (Black 1)	E N B	10	7			
Pink	White (Red 1)	E N B	9	8			
			8	9			
Yellow	Yellow (Black 1)	V P S	7	10	V B B	Blue	Pink (Black 1)
Orange	Pink (Red 1)	V B B	6	11	V P S	Orange	Pink (Red 1)
Blue	Pink (Black 1)	GND	5	12			
			4	13			
			3	14	L S +	Blue (Red 1)	Orange (Black 2)
			2	15	L S -	White	Orange (Black 2)
			1	16			
				17	B K +	Red	Orange (Black 1)
				18	B K -	Gray	Orange (Red 1)
					F G	Ground	Ground

Encoder Cable / Encoder Robot Cable for RCP2-RA10C/HS8C/HS8R and RCP2W-RA10C/SA16C (PCON-CF)

Model **CB-RFA-PA** / **CB-RFA-PA** - **RB** * The standard cable for the encoder cable is the normal cable. * Enter the cable length (L) into . Compatible to a maximum of 20 meters. Ex.: 080 = 8 m

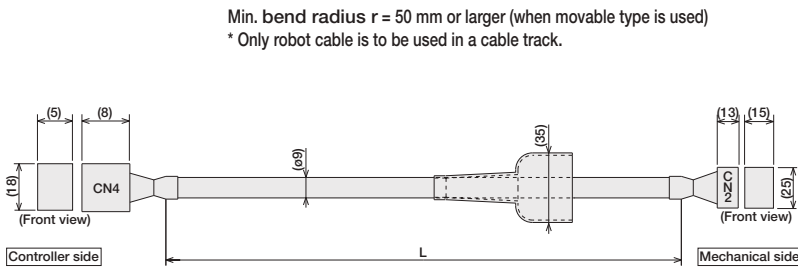

Min. bend radius $r = 50$ mm or larger (when movable type is used)
* Only robot cable is to be used in a cable track.

CN2				CN1			
Robot Cable	Standard Cable	Signal	Pin No.	Pin No.	Signal	Standard Cable	Robot Cable
-	-	Spares	16	1	ENA	Brown	Light Gray (Red 1)
Orange (Black 1)	Red	BK+	14	2	ENA	Green	Light Gray (Red 1)
Orange (Red 1)	Gray	BK-	13	3	ENB	Purple	White (Black 1)
Light Gray (Black 1)	Brown	ENA	12	4	ENB	Pink	White (Red 1)
Light Gray (Red 1)	Green	ENB	11	5	-	-	-
White (Black 1)	Purple	ENB	10	6	-	-	-
White (Red 1)	Pink	ENB	9	7	-	-	-
-	-	Spares	8	8	-	-	-
Yellow (Black 1)	Yellow	VPS	7	9	GND	Blue	Pink (Red 1)
-	-	-	6	10	-	-	-
Pink (Black 1)	Blue	cND	5	11	VPS	Yellow	Yellow (Black 1)
Pink (Red 1)	Orange	SV	4	12	SV	Orange	Pink (Red 1)
-	-	-	3	13	-	-	-
-	-	-	2	14	-	-	-
Ground	Ground	F.G	1	15	-	-	-

Housing: PHDR-16VS (JST)
Contact: SPHD-001T-P0.5

Housing: XMP-18V (JST)
Contact: BXA-001T-P0.6
Retainer: MS-09V

Motor-Encoder Integrated Type Cable for RCP3 and RCP2-GRSS/GRLS/GRST/GRHM/GRHB/SRA4R/SRGS4R/SRGD4R

Model **CB-PCS-MPA** * The standard cable is robot cable. * Enter the cable length (L) into . Compatible to a maximum of 20 meters. Ex.: 080 = 8 m

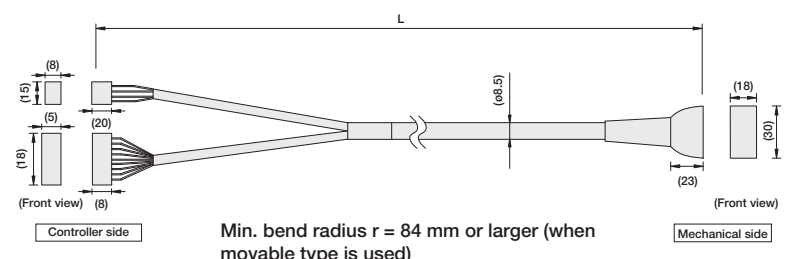

Min. bend radius $r = 84$ mm or larger (when movable type is used)

Signal	Pin No.	Wire color	Pin No.	Signal
VMM	A2	White	B1	VMM
/A	A1	Red	A2	/A
B	B3	Green	B2	B
VMM	B2	Yellow	A3	VMM
/B	A3	Brown	B3	/B
BK+	14	Pink (Red)	A4	NC
BK-	13	Blue	B4	NC
LS+	16	White (Red)	A5	BK+
LS-	15	White (Blue)	B5	BK-
A+	12	Orange (Red)	A6	LS+
A-	11	Orange (Blue)	B6	LS-
B+	10	Gray (Red)	A7	A+
B-	9	Gray (Blue)	B7	A-
NC	8	Shield	A8	B+
VPS	7	Orange (Blue)	B8	B-
VCP	6	Gray (Blue)	A9	NC
GND	5	Gray (Red)	B9	VPS
NC	4	Gray (Blue)	A10	VCP
F.G	1	Shield	B10	GND
			A11	NC
			B11	F.G

Positioner I/O Cable (for PCON-C/CG)

Model **CB-PAC-PIO** * Enter the cable length (L) into . Compatible to a maximum of 10 meters. Ex.: 080 = 8 m

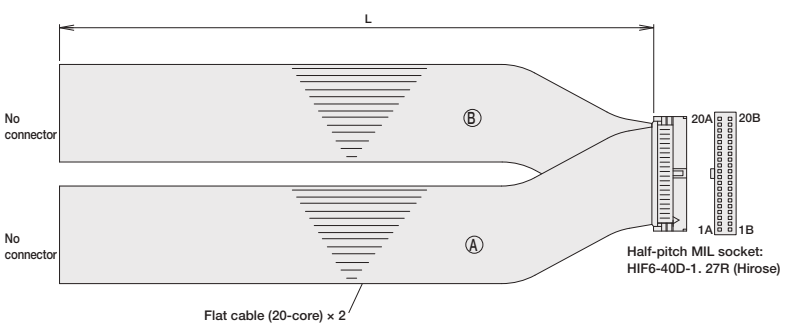

No.	Signal	Cable Color	Wire	No.	Signal	Cable Color	Wire
1A	24V	Brown-1	Flat cable A (crimped)	1B	OUT0	Brown-3	Flat cable B (crimped) AWG28
2A	24V	Red-1		2B	OUT1	Red-3	
3A	-	Orange-1		3B	OUT2	Orange-3	
4A	-	Yellow-1		4B	OUT3	Yellow-3	
5A	IN0	Green-1		5B	OUT4	Green-3	
6A	IN1	Blue-1		6B	OUT5	Blue-3	
7A	IN2	Purple-1		7B	OUT6	Purple-3	
8A	IN3	Gray-1		8B	OUT7	Gray-3	
9A	IN4	White-1		9B	OUT8	White-3	
10A	IN5	Black-1		10B	OUT9	Black-3	
11A	IN6	Brown-2		11B	OUT10	Brown-4	
12A	IN7	Red-2		12B	OUT11	Red-4	
13A	IN8	Orange-2		13B	OUT12	Orange-4	
14A	IN9	Yellow-2		14B	OUT13	Yellow-4	
15A	IN10	Green-2		15B	OUT14	Green-4	
16A	IN11	Blue-2		16B	OUT15	Blue-4	
17A	IN12	Purple-2		17B	-	Purple-4	
18A	IN13	Gray-2		18B	-	Gray-4	
19A	IN14	White-2		19B	0V	White-4	
20A	IN15	Black-2		20B	0V	Black-4	

Solenoid Valve Type I/O Cable (for PCON-CY)

Model **CB-PACY-PIO** * Enter the cable length (L) into . Compatible to a maximum of 10 meters. Ex.: 080 = 8 m

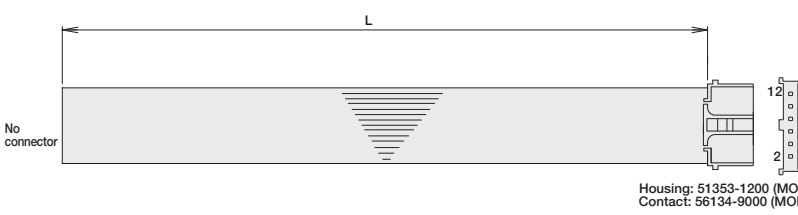

No.	Signal	Cable Color	Wire
1	24V	Brown-1	Flat cable (crimped) AWG28
2	0V	Red-1	
3	IN0	Orange-1	
4	IN1	Yellow-1	
5	IN2	Green-1	
6	IN3	Blue-1	
7	OUT0	Purple-1	
8	OUT1	Gray-1	
9	OUT2	White-1	
10	OUT3	Black-1	
11	OUT4	Brown-2	
12	OUT5	Red-2	

Pulse Train Control I/O Cable (for PCON-PL/PO)

Model **CB-PACPU-PIO** * Enter the cable length (L) into . Compatible to a maximum of 10 meters. Ex.: 080 = 8 m

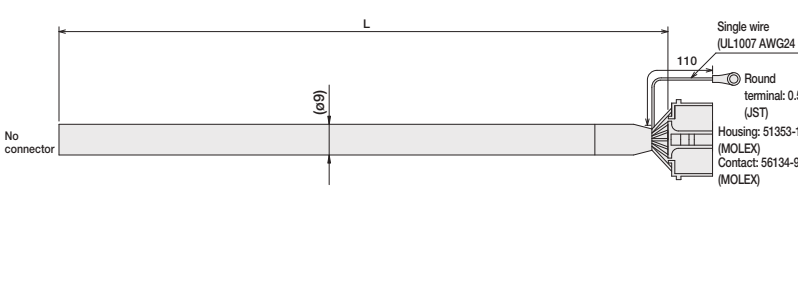

No.	Signal	Cable Color	Wire
1	IO 24V	Black	0.25sq
2	IO 24G	White/Black	
3	IN0	Red	
4	IN1	White/Red	
5	IN2	Green	
6	IN3	White/Green	
7	OUT0	Yellow	
8	OUT1	White/Yellow	
9	OUT2	Brown	
10	OUT3	White/Brown	
11	PP	Blue	
12	PG	White/Blue	
13	NP	Gray	
14	NG	White/Gray	

0.5-5 (JST)
1 F.G White/Gray AWG24

- Slider Type
- Mini
- Standard
- Controllers Integrated
- Rod Type
- Mini
- Standard
- Controllers Integrated
- Table/Arm /FlatType
- Mini
- Standard
- Gripper/ Rotary Type
- Linear Motor Type
- Cleanroom Type
- Splash-Proof
- Controllers
- PMEC /AMEC
- PSEP /ASEP
- ROBO NET
- ERC2
- PCON
- ACON
- SCON
- PSEL
- ASEL
- SSEL
- XSEL

PCON-ABU ACON-ABU

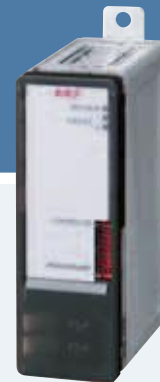

Simple absolute unit
For PCON/ACON/PSEL controller

Features

- 1 When attached to a ACON/PCON-C/-CG/-CY/-SE or PSEL-C (incremental) controller, the data from the encoder is retained even after the controller's main power has been turned OFF, allowing you to use it as an absolute model, which does not require homing at power-up.

* Cannot be used for ACON/PCON-PL or PO types.

Caution: The encoder type for the actuators and controllers with a simple absolute unit is "I" (incremental) and not "A" (absolute).

- 2 Having the same size as the CY and SE compact controllers (W 34mm x H 100mm x D 75.3mm), it can be installed in a small space.

- 3 Encoder data can be retained up to 20 days.

Caution: An error will occur if the actuator's slider or rod is moved faster than the fixed speed, while the encoder data is retained. Check the specifications table on page 546 for the allowable speed (rotations).

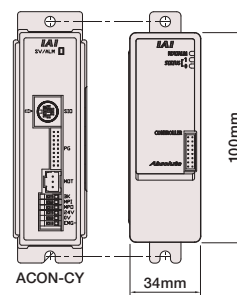
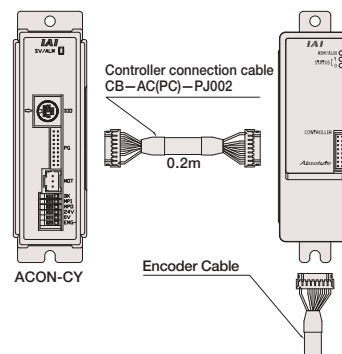

Dedicated controllers and software

Controller	PCON-C/CG/CY/SE	ACON-C/CG/CY/SE	PSEL-C
Absolute unit	PCON-ABU	ACON-ABU	PCON-ABU
PC software	RCM-101-MW/USB-EU, V6.0 or later		IA-101-X-MW/USB, V7.4 or later

Connectable actuator

The simple absolute unit is available for the following actuators. (Models other than following models are not available.)

Corresponding series	Reference
RCP3 series	Corresponding to all models
RCP2 series	Corresponding to all models other than HS8C/HS8R/RA10C.
RCP2 CR series	Corresponding to all models other than HS8C.
RCP2 W series	Corresponding to all models other than SA16C/RA10C.
RCA2 series	Corresponding to all models
RCA series	Corresponding to all models
RCA CR series	Corresponding to all models
RCA W series	Corresponding to all models

Specifications

Item	Details			
Model	ACON-ABU		PCON-ABU	
Connecting controller	ACON - C / CG / CY / SE		PCON - C / CG / CY / SE ; PSEL - C	
Connecting actuator	RCA2 / RCA series		RCP3/RCP2 series (* 1)	
Controller connection cable (included accessory)	Model CB - AC - PJ002 (0.2m)		Model CB - PC - PJ002 (0.2m)	
Simple absolute unit	Model ABU			
Backup battery (included accessory)	Model AB - 7 (Ni - MH battery / Life: approx. 3 years)			
Power supply voltage	DC24V±10%			
Power supply current	Max. 300 mA			
Ambient operating temperature	0 to 40°C (approx. 20°C is preferred)			
Ambient operating humidity	95% RH or lower (non-condensing)			
Ambient operating atmosphere	Without corrosive gases, without dust			
Weight	330g			
Allowable encoder RPM during data retention (*2)	800 rpm	400 rpm	200 rpm	100 rpm
Position data retaining time (*2)	120h	240h	360h	480h

(*1) Cannot be used with RCP2-RA10C/HS8C/HS8R/RCP2W-RA10C/SA16C

(*2) Position data retention time changes with the allowable encoder RPMs during data retention.

(800rpm → 120h / 400rpm → 240h / 200rpm → 360h / 100rpm → 480h)

External dimensions

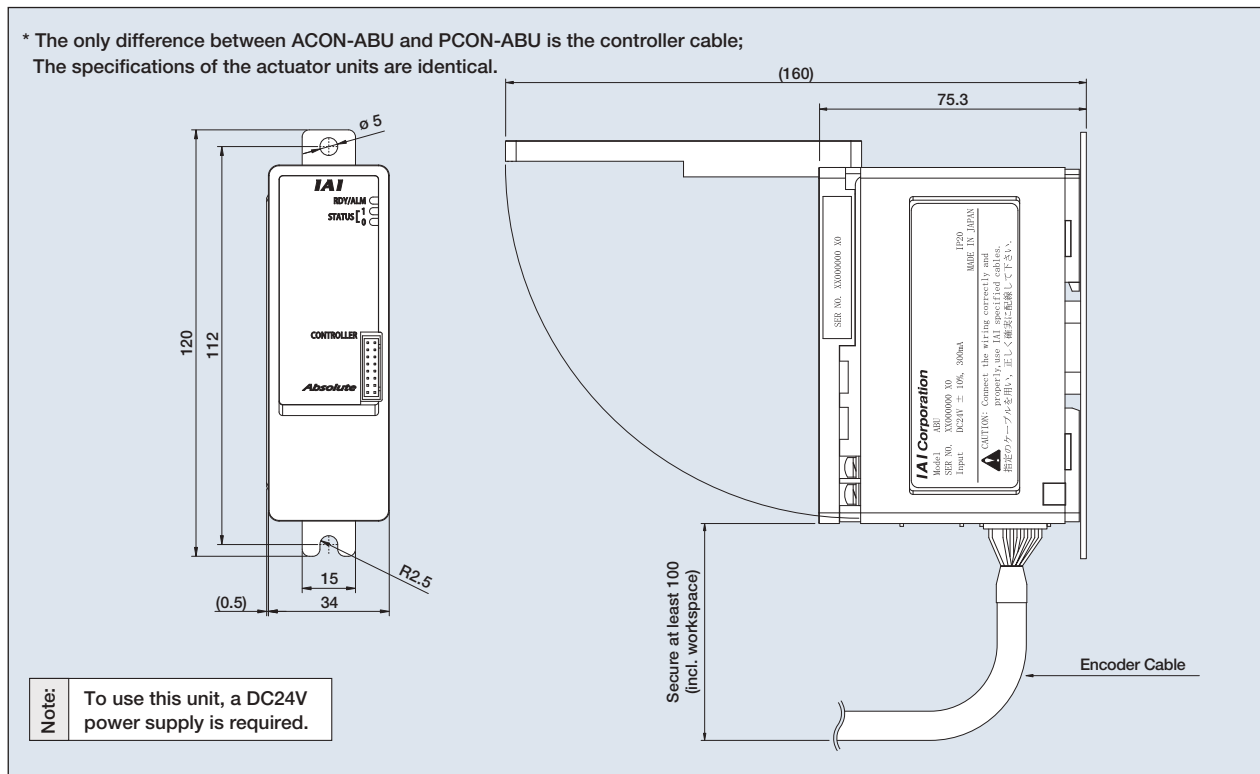

PSEL



Program controller
For RCP3/RCP2 series

List of models

Program controller for operating RCP3/RCP2 series actuators. Various control functions are combined into a single unit.

Type	C	
Name	Program mode	Positioner Mode
External View		
Description	Both the actuator operation and communication with external equipment can be handled by a single controller. When two axes are connected, arc interpolation, path operations, and synchronization can be performed.	Up to 1500 positioning points are supported. Push-motion operation and teaching operation are also possible.
Position points	1500 points	
Maximum number of control axes	2	

Model

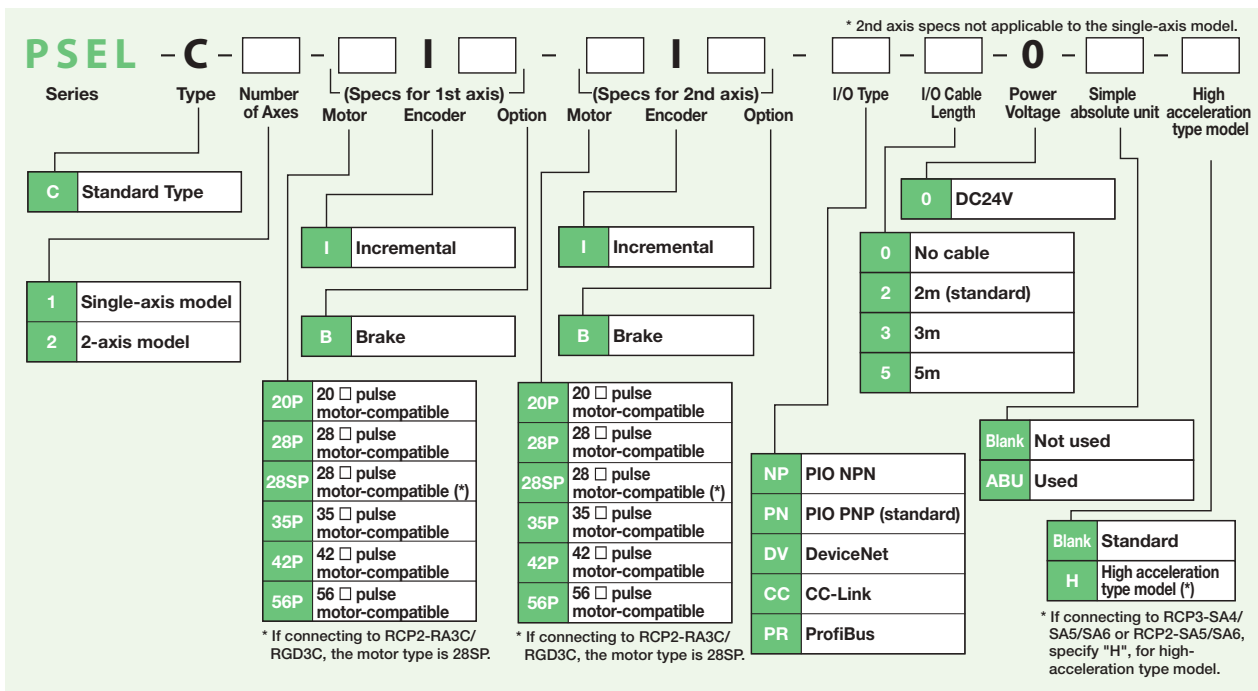

System configuration

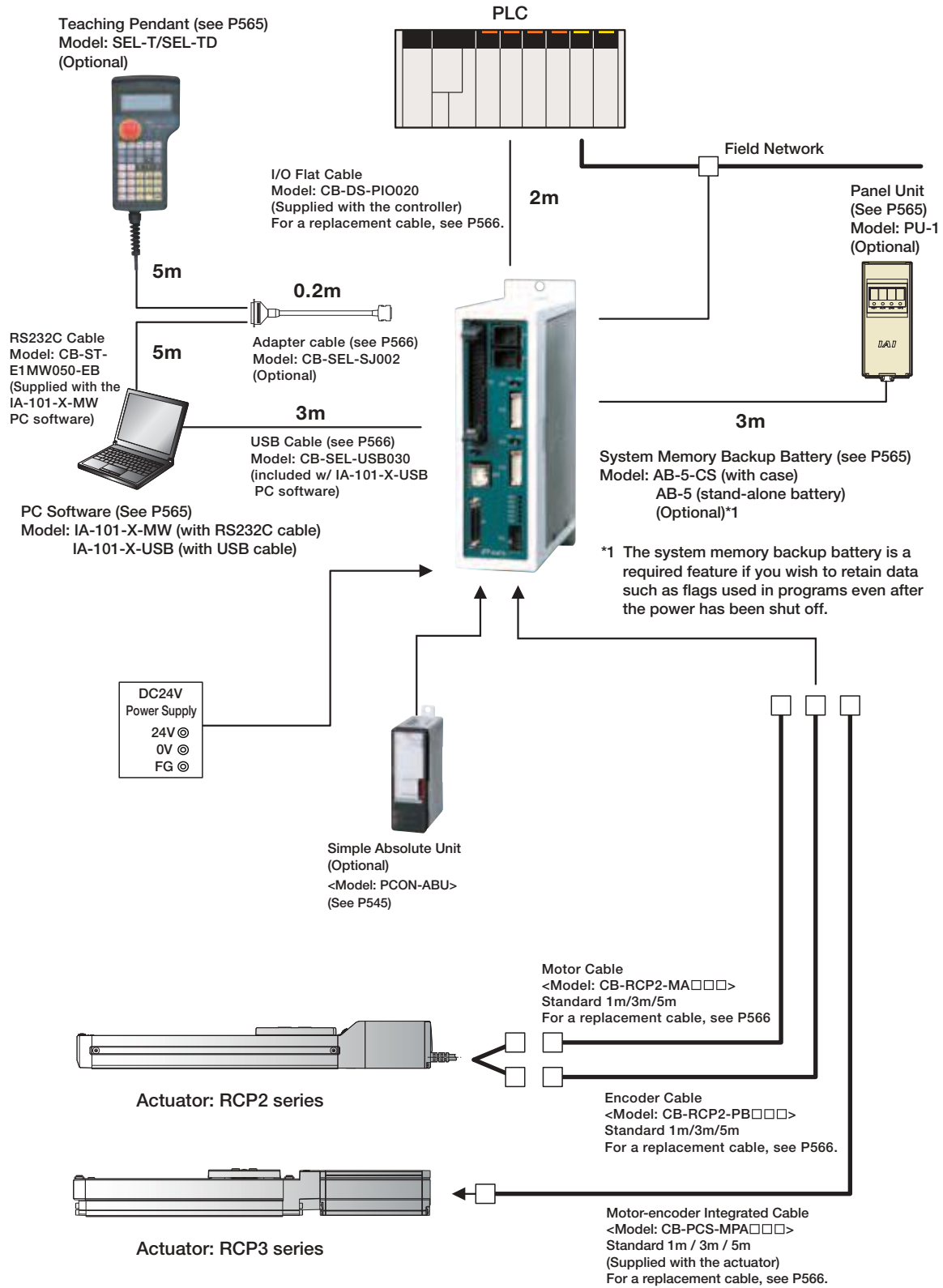

- Slider Type
- Mini
- Standard
- Controllers Integrated
- Rod Type
- Mini
- Standard
- Controllers Integrated
- Table/Arm /Flat Type
- Mini
- Standard
- Gripper/ Rotary Type
- Linear Motor Type
- Cleanroom Type
- Splash-Proof
- Controllers
- PMEC /AMEC
- PSEP /ASEP
- ROBO NET
- ERC2
- PCON
- ACON
- SCON
- PSEL
- ASEL
- SSEL
- XSEL
- Pulse Motor
- Servo Motor (24V)
- Servo Motor (230V)
- Linear Motor

I/O Specifications

Input section External input specifications

Item	Specifications
Input voltage	DC24V ±10%
Input current	7mA / circuit
ON/OFF voltage	ON voltage (min.) NPN : DC16V / PNP : DC8V OFF voltage (max.) NPN : DC5V / PNP : DC19V
Isolation method	Photocoupler

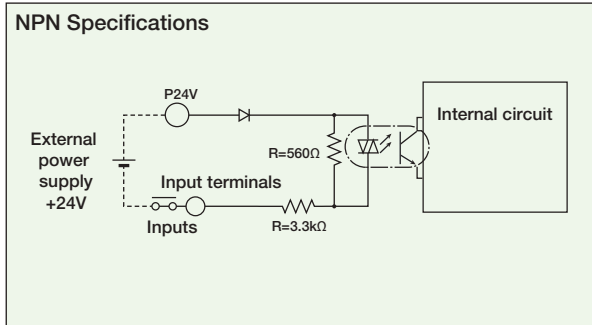

Output section External output specifications

Item	Specifications
Load Voltage	DC24V
Max. load current	100mA / 1 point 400mA / 8 points in total
Residual voltage (Max.)	Max 0.1mA / 1 point
Isolation method	Photocoupler

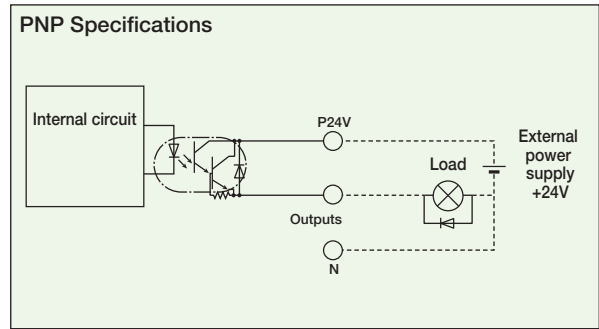
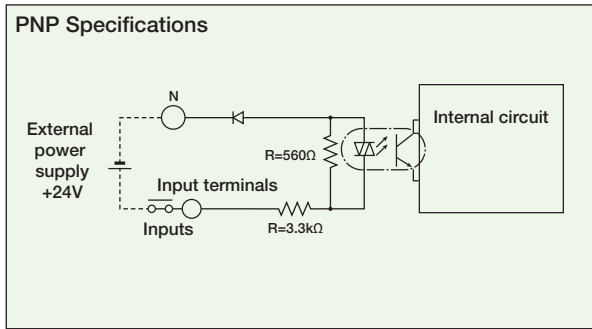
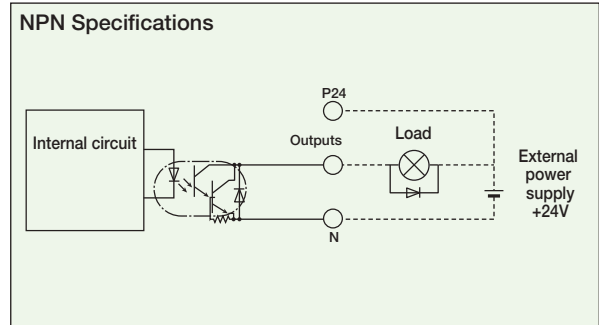

Explanation of I/O Signal Functions

Two modes can be selected for the SSEL controller: "Program Mode," in which the actuator is operated by entering a program, and "Positioner Mode," in which PLC signals are received and the actuator is moved to designated positions. The Positioner Mode has the five input patterns listed below to enable various applications.

Control Function by Type

Operation mode		Features
Program mode		Various operations including linear/arc interpolation operation, path operation ideal for coating processes, etc., arch-motion operation and palletizing operation can be performed using the Super SEL language that lets you program complex control actions using simple commands.
Positioner mode	Standard mode	This is the basic mode from which operations can be conducted by designating position numbers and inputting the start signal. Push-motion operation and teaching operation are also possible.
	Product Change mode	Multiple work parts of the same shape with slightly different hole positions can be handled using movement commands to the same position numbers by simply changing the product type number.
	2-axis independent mode	With a 2-axis controller, each axis can be commanded and operated separately.
	Teaching mode	In this mode, the slider (rod) moves based on an external signal, when the actuator is stopped, the current location can be registered as position data.
	DS-S-C1 Compatible mode	If you were using a DS-S-C1 controller, you can replace it with a PSEL controller without having to change the host programs. *This mode does not ensure actuator compatibility.

Explanation of I/O Signal Functions

Program mode

Pin Number	Classification	Port No.	Program Mode	Functions	NPN* Wiring Diagram	
1A	P24		24V input	Connect 24V.		
1B		016	Select Program No. 1	Selects the program number to start. (Input as BCD values to ports 016 to 022)		
2A		017	Select Program No. 2			
2B		018	Select Program No. 4			
3A		019	Select Program No. 8			
3B		020	Select Program No. 10			
4A		021	Select Program No. 20			
4B		022	Select Program No. 40			
5A		023	CPU reset	Resets the system to the same state as when the power is turned on.		
5B		000	Start	Starts the program selected by ports 016 to 022.		
6A		Input	001	General-purpose input		Waits for external input via program instructions.
6B			002	General-purpose input		
7A			003	General-purpose input		
7B			004	General-purpose input		
8A			005	General-purpose input		
8B			006	General-purpose input		
9A			007	General-purpose input		
9B	008		General-purpose input			
10A	009		General-purpose input			
10B	010		General-purpose input			
11A	011		General-purpose input			
11B	012		General-purpose input			
12A	013		General-purpose input			
12B	014	General-purpose input				
13A	015	General-purpose input				
13B	Output	300	Alarm	Turns off when an alarm occurs. (Contact B)		
14A		301	Ready	Turns on when the controller starts up normally and is in an operable state.		
14B		302	General-purpose output	These outputs can be turned ON/OFF as desired via program instructions.		
15A		303	General-purpose output			
15B		304	General-purpose output			
16A		305	General-purpose output			
16B		306	General-purpose output			
17A	307	General-purpose output				
17B	N	0V input	Connect 0V.			

*Note: With regard to PNP wiring diagram, please refer to PSEL manual.

Positioner mode

Pin Number	Classification	Port No.	Positioner Standard Mode	Functions	NPN* Wiring Diagram	
1A	P24		24V input	Connect 24V.		
1B		016	Position input 10	Specifies the position numbers to move to, using port number 007 to 019. The number can be specified either as BCD or binary.		
2A		017	Position input 11			
2B		018	Position input 12			
3A		019	Position input 13			
3B		020	-			
4A		021	-			
4B		022	-			
5A		023	Error reset			Resets minor errors. (Severe errors require a restart.)
5B		000	Start			Starts moving to selected position.
6A		Input	001	Home return		Performs home return.
6B			002	Servo ON		Switches between Servo ON and OFF.
7A			003	Push		Performs a push motion.
7B			004	Pause		Pauses the motion when turned OFF, and resumes when turned ON.
8A			005	Cancel		Stops the motion when turned OFF. The remaining motion is canceled.
8B			006	Interpolation settings		When this signal is turned ON for a 2-axis model, the actuator moves by linear interpolation.
9A			007	Position input 1		Specifies the position numbers to move to, using ports 007 to 019. The number can be specified either as BCD or binary.
9B	008		Position input 2			
10A	009		Position input 3			
10B	010		Position input 4			
11A	011		Position input 5			
11B	012		Position input 6			
12A	013		Position input 7			
12B	014	Position input 8				
13A	015	Position input 9				
13B	Output	300	Alarm	Turns off when an alarm occurs. (Contact B)		
14A		301	Ready	Turns on when the controller starts up normally and is in an operable state.		
14B		302	Positioning complete	Turns on when the movement to the destination is complete.		
15A		303	Home return complete	Turns on when the home return operation is complete.		
15B		304	Servo ON output	Turns on when servo is ON.		
16A		305	Pushing complete	Turns on when a push motion is complete.		
16B		306	System battery error	Turns on when the system battery runs low (warning level).		
17A	307	-	-			
17B	N	0V input	Connect 0V.			

*Note: With regard to PNP wiring diagram, please refer to PSEL manual.

- Slider Type
- Mini
- Standard
- Controllers Integrated
- Rod Type
- Mini
- Standard
- Controllers Integrated
- Table/Arm /Flat Type
- Mini
- Standard
- Gripper/ Rotary Type
- Linear Motor Type
- Cleanroom Type
- Splash-Proof
- Controllers
- PMEC /AMEC
- PSEP /ASEP
- ROBO NET
- ERC2
- PCON
- ACON
- SCON
- PSEL
- ASEL
- SSEL
- XSEL
- Pulse Motor
- Servo Motor (24V)
- Servo Motor (230V)
- Linear Motor

Explanation of I/O Signal Functions

Positioner, Product-Type Change Mode

Pin Number	Classification	Port No.	Positioner Product Type Change Mode	Functions	NPN* Wiring Diagram	
1A	P24		24V input	Connect 24V.		
1B		016	Position/Product Type Input 10	Specifies the position numbers to move to, and the product type numbers, using ports 007 to 022. The position and product type numbers are assigned by parameter settings. The number can be specified either as BCD or binary.		
2A		017	Position/Product Type Input 11			
2B		018	Position/Product Type Input 12			
3A		019	Position/Product Type Input 13			
3B		020	Position/Product Type Input 14			
4A		021	Position/Product Type Input 15			
4B		022	Position/Product Type Input 16			
5A		023	Error reset			Resets minor errors. (Severe errors require a restart.)
5B		000	Start			Starts moving to selected position.
6A		001	Home return			Performs home return.
6B		002	Servo ON			Switches between Servo ON and OFF.
7A		003	Push			Performs a push motion.
7B		004	Pause			Pauses the motion when turned OFF, and resumes when turned ON.
8A		005	Cancel			Stops the motion when turned OFF. The remaining motion is canceled.
8B		006	Interpolation settings			When this signal is turned ON for a 2-axis model, the actuator moves by linear interpolation.
9A		007	Position/Product Type Input 1			Specifies the position numbers to move to, and the product type numbers, using ports 007 to 022. The position and product type numbers are assigned by parameter settings. The number can be specified either as BCD or binary.
9B		008	Position/Product Type Input 2			
10A		009	Position/Product Type Input 3			
10B		010	Position/Product Type Input 4			
11A		011	Position/Product Type Input 5			
11B		012	Position/Product Type Input 6			
12A		013	Position/Product Type Input 7			
12B		014	Position/Product Type Input 8			
13A		015	Position/Product Type Input 9			
13B		300	Alarm	Turns off when an alarm occurs. (Contact B)		
14A		301	Ready	Turns on when the controller starts up normally and is in an operable state.		
14B		302	Positioning complete	Turns on when the movement to the destination is complete.		
15A		303	Home return complete	Turns on when the home return operation is complete.		
15B		304	Servo ON output	Turns on when servo is ON.		
16A		305	Pushing complete	Turns on when a push motion is complete.		
16B		306	System battery error	Turns on when the system battery runs low (warning level).		
17A		307	-	-		
17B	N		0V input	Connect 0V.		

*Note: With regard to PNP wiring diagram, please refer to PSEL manual.

Positioner, 2-axis Independent Mode

Pin Number	Classification	Port No.	Positioner 2-axis Independent Mode	Functions	NPN* Wiring Diagram	
1A	P24		24V input	Connect 24V.		
1B		016	Position input 7	Specifies the position numbers to move to, using ports 010 to 022. The position numbers on the 1st and 2nd axes are assigned by parameter settings. The number can be specified either as BCD or binary.		
2A		017	Position input 8			
2B		018	Position input 9			
3A		019	Position input 10			
3B		020	Position input 11			
4A		021	Position input 12			
4B		022	Position input 13			
5A		023	Error reset			Resets minor errors. (Severe errors require a restart.)
5B		000	Start 1			Starts the movement to the selected position number on the 1st axis.
6A		001	Home return 1			Performs home return on the 1st axis.
6B		002	Servo ON 1			Switches between servo ON and OFF for the 1st axis.
7A		003	Pause 1			Pauses the motion on 1st axis when turned OFF, and resumes when turned ON.
7B		004	Cancel 1			Cancels the movement on the 1st axis.
8A		005	Start 2	Starts the movement to the selected position number on the 2nd axis.		
8B		006	Home return 2	Performs home return on the 2nd axis.		
9A		007	Servo ON 2	Switches between servo ON and OFF for the 2nd axis.		
9B		008	Pause 2	Pauses the motion on 2nd axis when turned OFF, and resumes when turned ON.		
10A		009	Cancel 2	Cancels the movement on the 2nd axis.		
10B		010	Position input 1	Specifies the position numbers to move to, using ports 010 to 022. The position numbers on the 1st and 2nd axes are assigned by parameter settings. The number can be specified either as BCD or binary.		
11A		011	Position input 2			
11B		012	Position input 3			
12A		013	Position input 4			
12B		014	Position input 5			
13A		015	Position input 6			
13B		300	Alarm	Turns off when an alarm occurs. (Contact B)		
14A		301	Ready	Turns on when the controller starts up normally and is in an operable state.		
14B		302	Positioning complete 1	Turns on when the movement to the specified position on the 1st axis is complete.		
15A		303	Home return complete 1	Turns on when home return on the 1st axis is complete.		
15B		304	Servo ON output 1	Turns on when the 1st axis is in a servo ON state.		
16A		305	Positioning complete 2	Turns on when the movement to the specified position on the 2nd axis is complete.		
16B		306	Home return complete 2	Turns on when home return on the 2nd axis is complete.		
17A		307	Servo ON output 2	Turns on when the 2nd axis is in a servo ON state.		
17B	N		0V input	Connect 0V.		

*Note: With regard to PNP wiring diagram, please refer to PSEL manual.

Explanation of I/O Signal Functions

Positioner, Teaching Mode

Pin Number	Classification	Port No.	Positioner Teaching Mode	Functions	NPN* Wiring Diagram
1A	P24		24V input	Connect 24V.	
1B		016	JOG- on 1st axis	While the signal is on, the 1st axis is moved in the - (negative) direction.	
2A		017	JOG+ on 2nd axis	While the signal is on, the 2nd axis is moved in the + (positive) direction.	
2B		018	JOG- on 2nd axis	While the signal is on, the 2nd axis is moved in the - (negative) direction.	
3A		019	Specify inching (0.01mm)	Specifies how much to move during inching. (Total of the values specified for ports 019 to 022)	
3B		020	Specify inching (0.1mm)		
4A		021	Specify inching (0.5mm)		
4B		022	Specify inching (1mm)		
5A		023	Error reset	Resets minor errors. (Severe errors require a restart.)	
5B		000	Start	Starts moving to selected position.	
6A		001	Servo ON	Switches between Servo ON and OFF.	
6B		002	Pause	Pauses the motion when turned OFF, and resumes when turned ON.	
7A	Input	003	Position input 1	Ports 003 to 013 are used to specify the position number to move, and the position number for inputting the current position. - When the teaching mode setting on port 014 is in the ON state, the current value is written to the specified position number.	
7B		004	Position input 2		
8A		005	Position input 3		
8B		006	Position input 4		
9A		007	Position input 5		
9B		008	Position input 6		
10A		009	Position input 7		
10B		010	Position input 8		
11A		011	Position input 9		
11B		012	Position input 10		
12A		013	Position input 11		
12B	014	Teaching mode setting			
13A		015	JOG+ on 1st axis	While the signal is on, the 1st axis is moved in the + (positive) direction.	
13B	Output	300	Alarm	Turns off when an alarm occurs. (Contact B)	
14A		301	Ready	Turns on when the controller starts up normally and is in an operable state.	
14B		302	Positioning complete	Turns on when the movement to the destination is complete.	
15A		303	Home return complete	Turns on when the home return operation is complete.	
15B		304	Servo ON output	Turns on when servo is ON.	
16A		305	-	-	
16B		306	System battery error	Turns on when the system battery runs low (warning level).	
17A	307	-	-		
17B	N		0V input	Connect 0V.	

*Note: With regard to PNP wiring diagram, please refer to PSEL manual.

0V 24

Positioner, DS-S-C1 Compatible Mode

Pin Number	Classification	Port No.	Positioner DS-S-C1 Compatible Mode	Functions	NPN* Wiring Diagram
1A	P24		24V input	Connect 24V.	
1B		016	Position No. 1000	(Same as ports 004 through 015)	
2A		017	-	-	
2B		018	-	-	
3A		019	-	-	
3B		020	-	-	
4A		021	-	-	
4B		022	-	-	
5A		023	CPU reset	Resets the system to the same state as when the power is turned on.	
5B		000	Start	Starts moving to selected position.	
6A		001	Hold (Pause)	Pauses the motion when turned ON, and resumes when turned OFF.	
6B		002	Cancel	Stops the motion when turned ON. The remaining motion is canceled.	
7A	Input	003	Interpolation settings	When this signal is turned ON for a 2-axis model, the actuator moves by linear interpolation. Ports 004 through 016 are used to specify the position number to move. The numbers are specified as BCD.	
7B		004	Position No. 1		
8A		005	Position No. 2		
8B		006	Position No. 4		
9A		007	Position No. 8		
9B		008	Position No. 10		
10A		009	Position No. 20		
10B		010	Position No. 40		
11A		011	Position No. 80		
11B		012	Position No. 100		
12A		013	Position No. 200		
12B	014	Position No. 400			
13A		015	Position No. 800		
13B	Output	300	Alarm	Turns off when an alarm occurs. (Contact A)	
14A		301	Ready	Turns on when the controller starts up normally and is in an operable state.	
14B		302	Positioning complete	Turns on when the movement to the destination is complete.	
15A		303	-	-	
15B		304	-	-	
16A		305	-	-	
16B		306	System battery error	Turns on when the system battery runs low (warning level).	
17A	307	-	-		
17B	N		0V input	Connect 0V.	

*Note: With regard to PNP wiring diagram, please refer to PSEL manual.

0V 24

- Slider Type
- Mini
- Standard
- Controllers Integrated
- Rod Type
- Mini
- Standard
- Controllers Integrated
- Table/Arm /Flat Type
- Mini
- Standard
- Gripper/ Rotary Type
- Linear Motor Type
- Cleanroom Type
- Splash-Proof
- Controllers
- PMEC /AMEC
- PSEP /ASEP
- ROBO NET
- ERC2
- PCON
- ACON
- SCON
- PSEL
- ASEL
- SSEL
- XSEL
- Pulse Motor
- Servo Motor (24V)
- Servo Motor (230V)
- Linear Motor

Table of specifications

	Item	Specifications
Basic Specifications	Connected actuator	RCP2/RCP3 series actuator (Note 1)
	Input voltage	DC24V ±10%
	Power Supply Capacity	Control power (Max. 1.2A) + Motor power (See the table below)
	Dielectric strength voltage	DC500V 10MΩ or higher
	Withstand voltage	AC500V 1 min.
	Rush current	Max. 30A
	Vibration resistance	XYZ directions 10 to 57Hz, One side amplitude: 0.035mm (continuous), 0.075mm (intermittent) 58 to 150 Hz 4.9 m/s ² (continuous), 9.8 m/s ² (intermittent)
Control specification	Maximum total output of connected axis	-
	Position detection method	Incremental encoder
	Speed setting	From 1mm/s. The maximum limit varies depending on the actuator.
	Acceleration setting	From 0.01G. The maximum limit varies depending on the actuator.
	Operating method	Program operation / Positioner operation (switchable)
Program	Programming language	Super SEL language
	Number of programs	64 programs
	Number of program steps	2000 steps
	Number of multi-tasking programs	8 programs
	Positioning Points	1500 points
	Data memory device	FLASHROM (A system-memory backup battery can be added as an option)
Communication	Data input method	Teaching pendant or PC software
	Number of I/O	24 input points / 8 output points (NPN or PNP selectable)
	I/O power	Externally supplied 24VDC ± 10%
	PIO cable	CB-DS-PIO □□□ (supplied with the controller)
	Serial communications function	RS232C (Half-pitch connector) / USB connector
	Field Network	DeviceNet, CC-Link, ProfiBus
	Motor Cable	RCP2:CB-RCP2-MA □□□ (Max. 20m) / RCP3: CB-PCS-MPA □□□ (Max. 20m)
	Encoder cable	RCP2:CB-RCP2-PA □□□ (Max. 20m) / RCP3: see motor cable (dual motor-encoder cable)
General specifications	Protection function	Motor driver temperature check, Encoder open-circuit check Soft limit over, system error, battery error, etc.
	Ambient operating humidity and temperature	0 to 40°C 10 to 95% (non-condensing)
	Ambient atmosphere	Free from corrosive gases. In particular, there shall be no significant powder dust.
	Protection class	IP20
	Weight	Approx. 450g
	External dimension	43 mm (W) x 159 mm (H) x 110 mm (D)

(Note 1) Cannot operate High-Thrust type (RA10C), High-Speed type (HS8C/HS8R), or Waterproof type (RCP2W-SA16).

Motorpower supply Capacity (Note2)	Motor type	1-Axis specifications		2-Axis specifications	
		Rated	Max.(Note 3)	Rated	Max.(Note 3)
	20P, 28P, 28SP motor	0.4A	2.0A	0.8A	4.0A
	35P, 42P, 56SP motor	1.2A		2.4A	

(Note 2) For both 1-axis and 2-axis specifications, approx. 30A inrush current flows for 5 ms when the control power supply is turned on.

(Note 3) After Servo ON, excitation detection is performed. In that case, the current is maximized. (Approx. 100 msec)

However, if motor drive power supply is turned on after a shut-down, approx. 6.0A and approx. 12.0A current flows to axis-1 and axis-2 respectively. (Approx. 1 to 2 msec)

Exterior dimensions

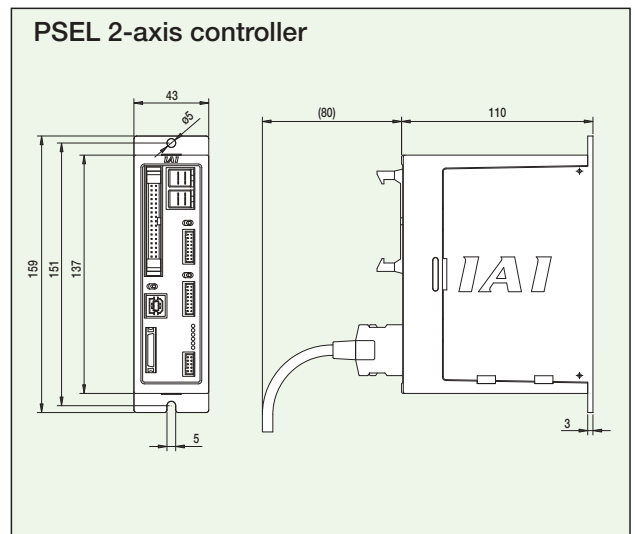
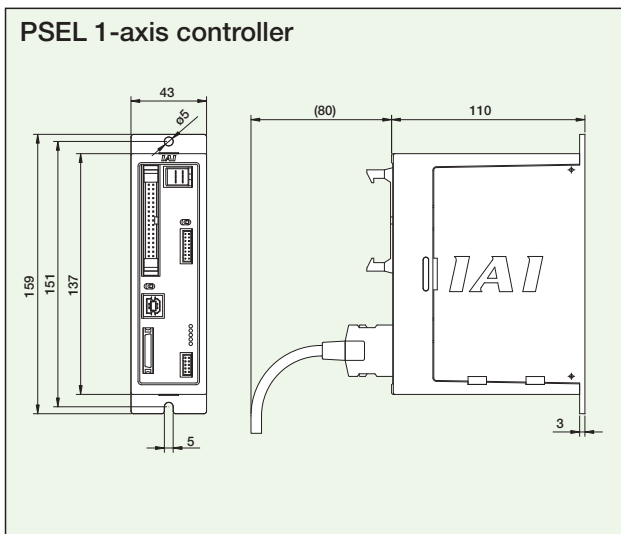

Name of Each Part

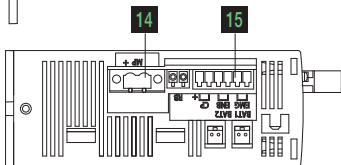
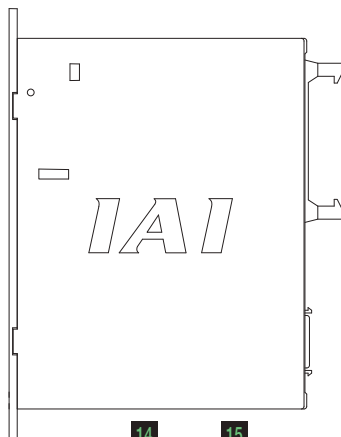
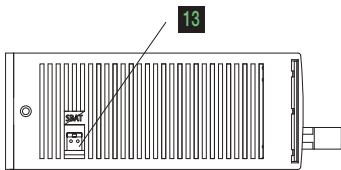
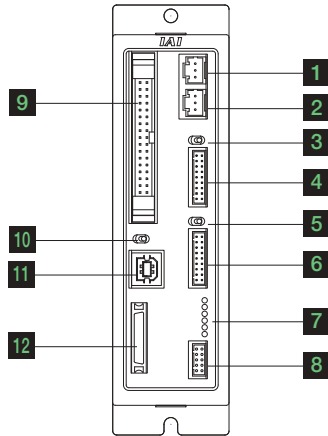

1 Motor connector for axis 1

Connects the motor cable of the axis 1 actuator.

2 Motor connector for axis 2

Connects the motor cable of the axis 2 actuator.

3 Brake switch for axis 1

This switch is used to release the axis brake. Setting it to the left position (RLS side) forcibly releases the brake, while setting it to the right position (NOM side) causes the controller to automatically control the brake.

4 Encoder connector for axis 1

Connect the encoder cable of the axis 1 actuator.

5 Brake switch for axis 2

This switch is used to release the axis brake. Setting it to the left position (RLS side) forcibly releases the brake, while setting it to the right position (NOM side) causes the controller to automatically control the brake.

6 Encoder connector for axis 2

Connect the encoder cable of the axis 2 actuator.

7 Status indicator LEDs

These LEDs are used to indicate the operating condition of the controller.

The LED status indicators are as follows:

- PWR : Power is input to controller.
- RDY : The controller is ready to perform program operation.
- ALM : The controller is abnormal.
- EMG : An emergency stop is actuated and the drive source is cut off.
- SV1 : The axis 1 actuator servo is on.
- SV2 : The axis 2 actuator servo is on.

8 Panel unit connector

A connector for the panel unit (optional) that displays the controller status and error codes.

9 I/O Connector

A connector for interface I/Os.

34-pin flat cable connector for DIO (24IN/8OUT) interface.

I/O power is also supplied to the controller via this connector (Pin No. 1 and No. 34).

10 Mode switch

This switch is used to specify the running mode of the controller. The left position indicates the MANU (manual operation) mode, while the right position indicates the AUTO (automatic operation) mode. Teaching can only be performed in manual operation, and automatic operation using external I/Os is not possible in the MANU mode.

11 USB connector

A connector for PC connection via USB. If the USB connector is connected, the TP connector is disabled and all communication inputs to the TP connector are cut off.

12 Teaching pendant connector

A half-pitch I/O 26-pin connector that connects a teaching pendant when the running mode is MANU. A special conversion cable is needed to connect a conventional D-sub, 25-pin connector.

13 System-memory backup battery connector

If you wish to retain the various data recorded in the SRAM of the controller even after the power is cut off, connect the necessary battery to this connector. This battery is installed externally to the unit. The controller does not come standard with the battery (Option).

14 Motor power input connector

This connector is used to input the motor power. It consists of a 2-pin, 2-piece connector by Phoenix Contact.

15 Control power/System input connector

This connector is used to connect the control power input, emergency stop switch, and enable switch. It consists of a Phoenix Contact 6-pin 2-piece connector.

- Slider Type
- Mini
- Standard
- Controllers Integrated
- Rod Type
- Mini
- Standard
- Controllers Integrated
- Table/Arm /Flat Type
- Mini
- Standard
- Gripper/ Rotary Type
- Linear Motor Type
- Cleanroom Type
- Splash-Proof
- Controllers
- PMEC /AMEC
- PSEP /ASEP
- ROBO NET
- ERC2
- PCON
- ACON
- SCON
- PSEL
- ASEL
- SSEL
- XSEL

- Pulse Motor
- Servo Motor (24V)
- Servo Motor (230V)
- Linear Motor

Option

Teaching Pendant

Features This is a teaching device that provides information on functions such as position input, test runs, and monitoring.

Model

Model	Description
SEL-T-J	Standard type with adapter cable
SEL-TD-J	Equipped with a deadman switch and adapter cable

Configuration

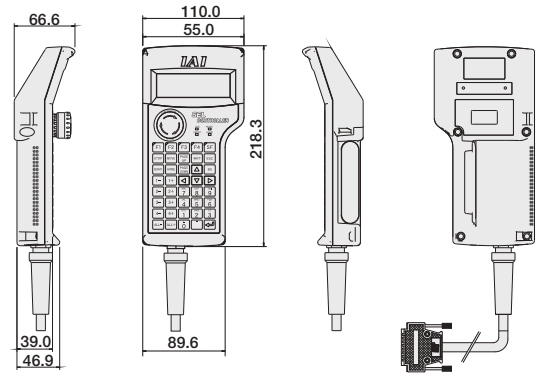
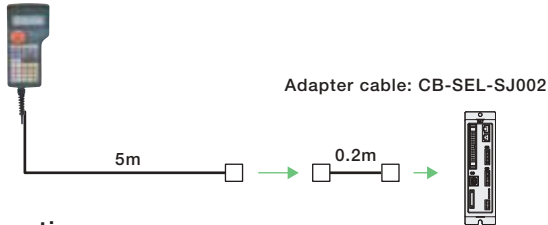

Specifications

Item	SEL-T-J	SEL-TD-J
3-position Enable Switch	No	Yes
ANSI/UL standards	Non-compliant	Compliant
CE mark	Compliant	
Display	20 char. x 4 lines	
Ambient Operating Temp./Humidity	0~40°C 10~90% RH (non-condensing)	
Protective structure	IP54	
Weight	Approx. 0.4kg (not incl. cable)	

SEL-T option

- Wall-mounting hook Model HK-1
- Strap Model STR-1

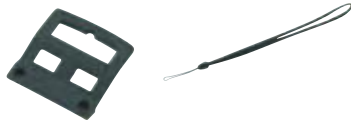

PC Software (Windows Only)

Features A startup support software for inputting programs/positions, performing test runs, and monitoring. More functions have been added for debugging, and improvements have been made to shorten the start-up time.

Model IA-101-X-MW-J (with RS232C cable + adapter cable)
IA-101-X-MW (with RS232C cable)

Configuration

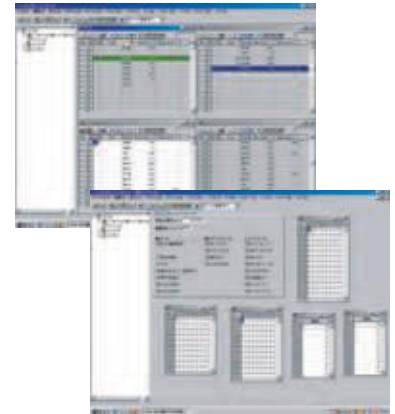
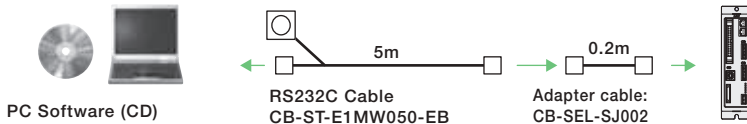

Model IA-101-X-USB (with USB cable)

Configuration

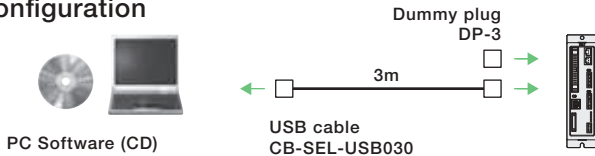

Note:
Only versions 7.0.0.0 and later can be used with the PSEL controller.

Panel Unit

Features Display device that shows the error code from the controller or the currently running program number.

Model PU-1 (Cable length: 3m)

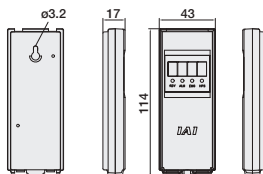

System Memory Backup Battery

Features This battery is required when you are using global flags in the program and you want to retain your data even after the power has been turned OFF.

Model AB-5-CS (with case)
AB-5 (stand-alone battery)



Dummy Plug

Features When connecting the PSEL controller to a computer with a USB cable, this plug is inserted in the teaching port to shut off the enable circuit. (Supplied with the PC software IA-101-X-USB)

Model DP-3



Option

USB Cable

- Features** A cable for connecting the controller to the USB port to a computer. A controller with no USB port (e.g. XSEL) can be connected to the USB port of a computer by connecting an RS232C cable to the USB cable via a USB adapter. (See PC software IA-101-X-USBMW)
- Model** **CB-SEL-USB030** (Cable length: 3m)



Adapter Cable

- Features** An adapter cable to connect the D-sub 25-pin connector from the teaching pendant or a PC to the teaching connector (half-pitch) of the PSEL controller.
- Model** **CB-SEL-SJ002** (Cable length: 0.2m)



Spare Parts

When you need spare parts after purchasing the product, such as when replacing a cable, refer to the list of models below.

Motor cable

Model **CB-RCP2-MA** ** The standard cable for the motor cable is the robot cable. * Enter the cable length (L) into . Compatible to a maximum of 20 meters. Ex.: 080 = 8 m

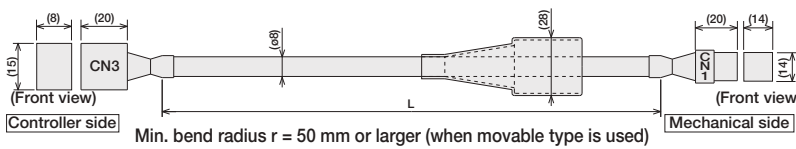

Wire	Color	Signal	Pin No.	Pin No.	Signal	Color	Wire
I-1318119-3 (AMP)	Orange	A	A1	1	A	Yellow	SLP-06V (JST)
	Gray	VMM	A2	2	VMM	Gray	
	White	B	A3	3	A	Orange	
	Yellow	A	B1	4	B	Orange (Black 1)	
	Pink	VMM	B2	5	VMM	Pink	
	Orange (Black 1)	B	B3	6	B	White	

Encoder cable/Encoder robot cable

Model **CB-RCP2-PB** / **CB-RCP2-PB** -**RB** * The standard cable for the encoder cable is a normal cable. * Enter the cable length (L) into . Compatible to a maximum of 20 meters. Ex.: 080 = 8 m

Min. bend radius r = 50 mm or larger (when movable type is used)
* Only robot cable is to be used in a cable track.

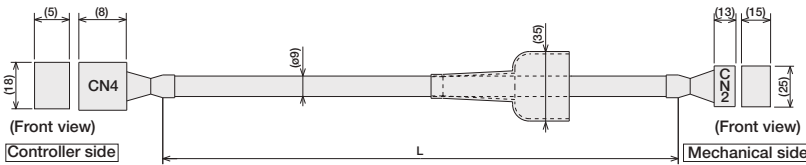

Cable color	Signal	Pin No.	Pin No.	Signal	Cable color
Blue (Red 1)	Orange (Black 2)	L S +	16	1	A
White	Orange (Red 2)	L S -	15	2	A
Red	Orange (Black 1)	B K +	14	3	A
Gray	Orange (Red 1)	B K -	13	4	B
Brown	Light Gray (Black 1)	E N A	12	5	B
Green	Light Gray (Red 1)	E N A	11	6	B
Purple	White (Black 1)	E N B	10	7	B
Pink	White (Red 1)	E N B	9	8	B
—	—	—	8	—	—
—	—	—	8	—	—
Yellow	Yellow (Black 1)	V P S	7	9	GND
Orange	Pink (Red 1)	V B B	6	10	V B B
Blue	Pink (Black 1)	GND	5	11	V P S
—	—	(N.C)	4	12	—
—	—	(N.C)	3	13	LS + Blue (Red 1)
—	—	(N.C)	2	14	LS - White
Ground	Ground	F.G	1	15	—
—	—	—	—	16	B K + Red
—	—	—	—	17	B K - Gray
—	—	—	—	18	F.G Ground

Motor-Encoder Integrated Cable for RCP3

Model **CB-PCS-MPA** * Enter the cable length (L) into . Compatible to a maximum of 20 meters. Ex.: 080 = 8 m

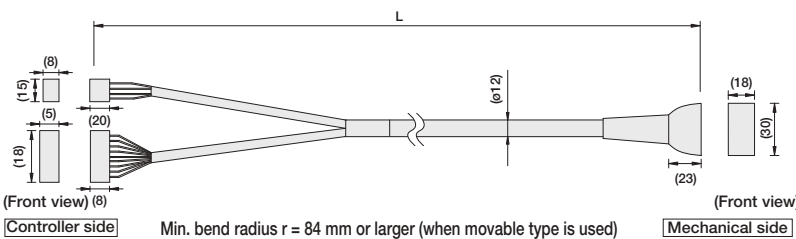

Signal	Pin Number	Wire color	Pin Number	Signal
A	B1	Black	A1	A
VMM	A2	White	B1	VMM
/A	A1	Red	A2	/A
B	B3	Green	B2	B
VMM	B2	Yellow	A3	VMM
/B	A3	Brown	B3	/B
—	—	—	A4	NC
—	—	—	B4	NC
—	—	—	A5	BK+
—	—	—	B5	BK-
—	—	—	A6	LS+
—	—	—	B6	LS-
—	—	—	A7	A+
—	—	—	B7	A-
—	—	—	A8	B+
—	—	—	B8	B-
—	—	—	A9	NC
—	—	—	B9	VPS
—	—	—	A10	VCC
—	—	—	B10	GND
—	—	—	A11	NC
—	—	—	B11	FG

I/O Flat Cable

Model **CB-DS-PIO** * Enter the cable length (L) into . Compatible to a maximum of 10 meters. Ex.: 080 = 8 m

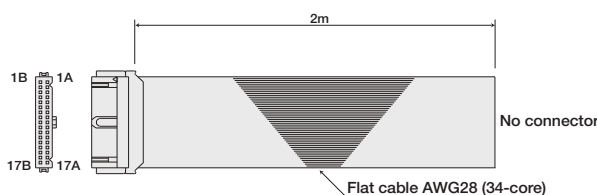

Pin No.	Color	Wire	Pin No.	Color	Wire
1A	Brown 1	Flat cable crimped	9B	Gray 2	Flat cable crimped
1B	Red 1		10A	White 2	
2A	Orange 1		10B	Black 2	
2B	Yellow 1		11A	Brown-3	
3A	Green 1		11B	Red 3	
3B	Blue 1		12A	Orange 3	
4A	Purple 1		12B	Yellow 3	
4B	Gray 1		13A	Green 3	
5A	White 1		13B	Blue 3	
5B	Black 1		14A	Purple 3	
6A	Brown-2		14B	Gray 3	
6B	Red 2		15A	White 3	
7A	Orange 2		15B	Black 3	
7B	Yellow 2		16A	Brown-4	
8A	Green 2		16B	Red 4	
8B	Blue 2		17A	Orange 4	
9A	Purple 2		17B	Yellow 4	

RCP2&RCP3 Series
Extract Cat. No. 0513-E

The information contained in this catalog is subject to change without notice for the purpose of product improvement



Providing quality products
since 1986



IAI Industrieroboter GmbH
Ober der Röth 4
D-65824 Schwalbach / Frankfurt
Germany
Tel.:+49-6196-8895-0
Fax:+49-6196-8895-24
E-Mail: info@IAI-GmbH.de
Internet: <http://www.eu.IAI-GmbH.de>

IAI America Inc.

2690 W. 237th Street, Torrance, CA 90505, U.S.A
Phone: +1-310-891-6015 Fax: +1-310-891-0815

IAI CORPORATION

645-1 Shimizu Hirose, Shizuoka 424-0102, Japan
Phone: +81-543-64-5105 Fax: +81-543-64-5182