

IAI
Quality and Innovation

ROBO Cylinder®
Rod type



RCP2-RA8C/RA8R



www.intelligentactuator.com

RA8 (85-mm wide) actuators have been added to the ROBO Cylinder® RCP2 series, rod type, to expand the lineup.

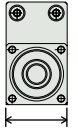
<RCP2 ROD TYPE VARIATIONS>

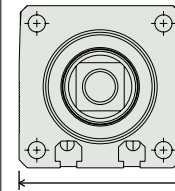
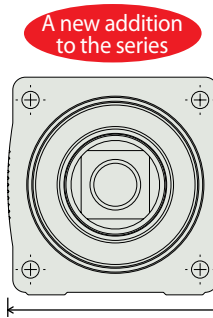
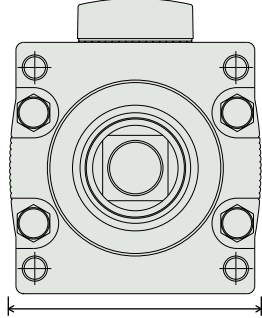
	RA2	RA3	RA4	RA6	RA8	RA10
Section view of the actuator						
Width	25mm	35mm	45mm	64mm	85mm	100mm
Maximum pushing force	100N	156.8N	358N	800N	1714N	6000N

Features



Coupling type
RCP2-RA8C

Side-mounted motor type
RCP2-RA8R

- The RA8 (pushing force: 1714 N), positioned between the RA6 (pushing force: 800 N) and RA10 (pushing force: 6000 N) size-wise, has been added to the series.
- The side-mounted motor type with a shorter overall length is available.
- A desired side-mounted motor direction and cable exit direction can be selected.

Specification table

	RA8C		RA8R	
Motor installation method	Coupling		Side-mounted	
Motor type	□ 60 Pulse motor			
Actuator section dimensions (*1) (mm)	85×86			
Stroke (mm)	50~300			
Drive system	Ø16 Ball screw		Ø16 Ball screw + Timing belt	
Ball screw lead (mm)	5	10	5	10
Maximum speed (mm/s)	150	300	100	200
Maximum pushing force (*2) (N)	1714	857	1714	857
Horizontal payload (*3) (kg)	100	60	100	60
Vertical payload (*3) (kg)	70	40	70	40
Positioning repeatability (mm)	±0.02			
Lost motion (mm)	0.1			
Rod non-rotation accuracy (deg)	±1.0			
Ambient operating temperature, humidity	0 to 40°C, 85%RH or less (No condensation)			

(*1) The motor dimensions are not included.

(*2) For the pushing force, refer to "Selection Guide (Correlation Diagrams of Pushing Force and Current Limiting Value)" on P6.

(*3) When the actuator is operated at a rated acceleration of 0.2 G (or 0.1 G if the lead is 5). The horizontal payload assumes use of an external guide. Due to the characteristics of the pulse motor, the payload will decrease as the speed increases. For details, refer to "Correlation Diagrams of Speed and Payload" on P6.

Model Description

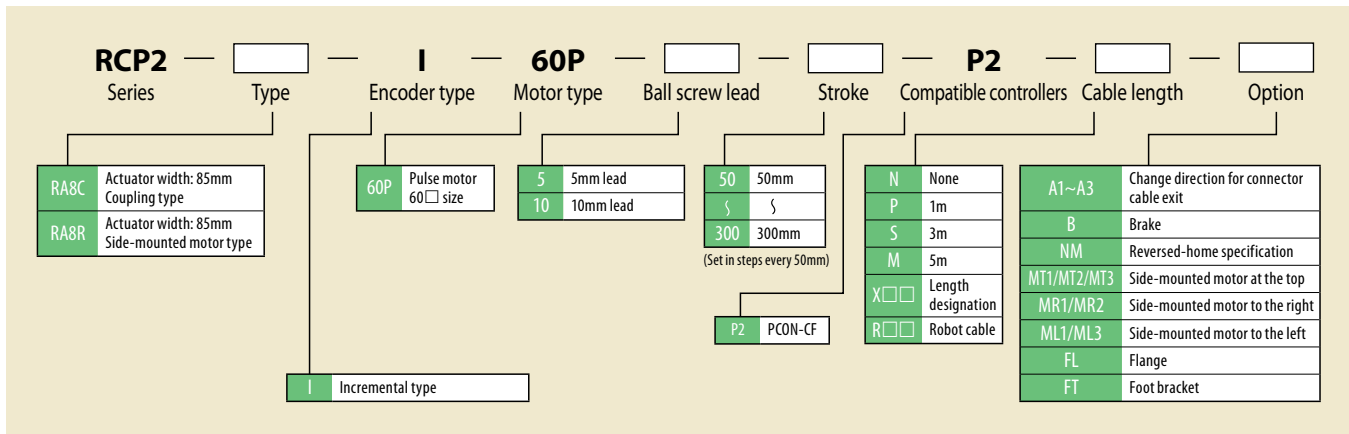

Change direction for cable exit

To change the direction for cable exit, indicate an appropriate option code such as A1, A2 or A3.

(Note) The direction for connector cable exit is determined by viewing from the rear of the motor.

Take note that the directions are reversed on the coupling type and side-mounted motor type.

Standard exit direction

■ No option specified (blank)

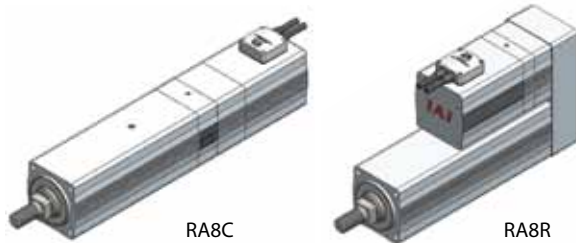

Cable exiting from the left direction

■ Option code: A1

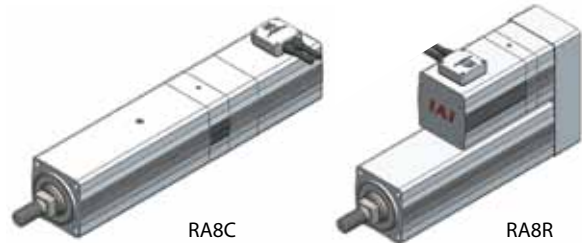

Cable exiting from the opposite side of the standard direction

■ Option code: A2

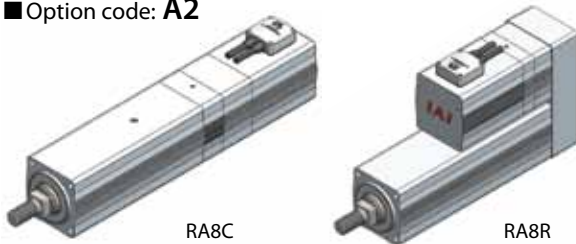

Cable exiting from the right direction

■ Option code: A3

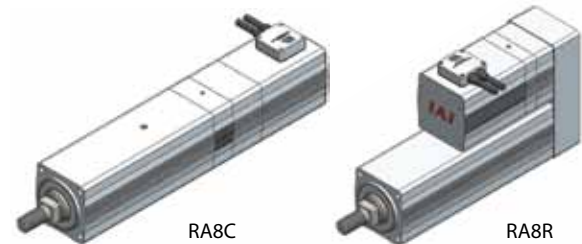

Side-mounted motor direction/cable exit position (for RA8R)

Note

Be sure to include the option code indicating the side-mounted motor direction/cable exit position for your model in the model number.



Option code	MT1	MT2	MT3	MR1	ML1	MR2	ML3
Side-mounted motor direction	Top (standard)	Top	Top	Right	Left	Right	Left
Cable exit position	Top (standard)	Right	Left	Top	Top	Right	Left

Stroke list

Stroke (mm)	Standard price	
	RA8C	RA8R
50	–	–
100	–	–
150	–	–
200	–	–
250	–	–
300	–	–

Cable list

Type	Cable symbol	Standard price
Standard type	P (1m)	–
	S (3m)	–
	M (5m)	–
Special length	X06 (6m) ~ X10 (10m)	–
	X11 (11m) ~ X15 (15m)	–
	X16 (16m) ~ X20 (20m)	–
Robot cable	R01 (1m) ~ R03 (3m)	–
	R04 (4m) ~ R05 (5m)	–
	R06 (6m) ~ R10 (10m)	–
	R11 (11m) ~ R15 (15m)	–
	R16 (16m) ~ R20 (20m)	–

Option list

Title	Option code	Standard price
Change direction for connector cable exit	A1~A3	–
Brake	B	–
Reversed-home specification	NM	–
Side-mounted motor at the top	MT1/MT2/MT3	–
Side-mounted motor to the right	MR1/MR2	–
Side-mounted motor to the left	ML1/ML3	–
Flange	FL	–
Foot bracket	FT	–

Controller

The RCP2-RA8C/RA8R controllers are shown below. For details, refer to the ROBO Cylinder® General Catalog.

Name	External view	Model number	Features	Maximum number of positioning points	Input power	Power supply capacity	Standard price
Positioner type		PCON-CF-60PI-NP-2-0	Up to 512 positioning points are supported	512 points	DC24V	6A max.	–

- Notes**
- Unlike with the PCON-C/CG/CY/PL/PO/SE controllers, the applicable encoder cable is designed exclusively for the PCON-CF type. Exercise caution when ordering this cable separately.
 - Take note that simple absolute units cannot be used.
 - For the details of controllers, refer to the ROBO Cylinder® General Catalog.

Dimensions

RA8C

Note

Do not apply an external force to the rod from any direction other than the moving direction of the rod. If a force is applied to the rod from the direction perpendicular to the rod or rotating direction of the rod, the stopper may be damaged.

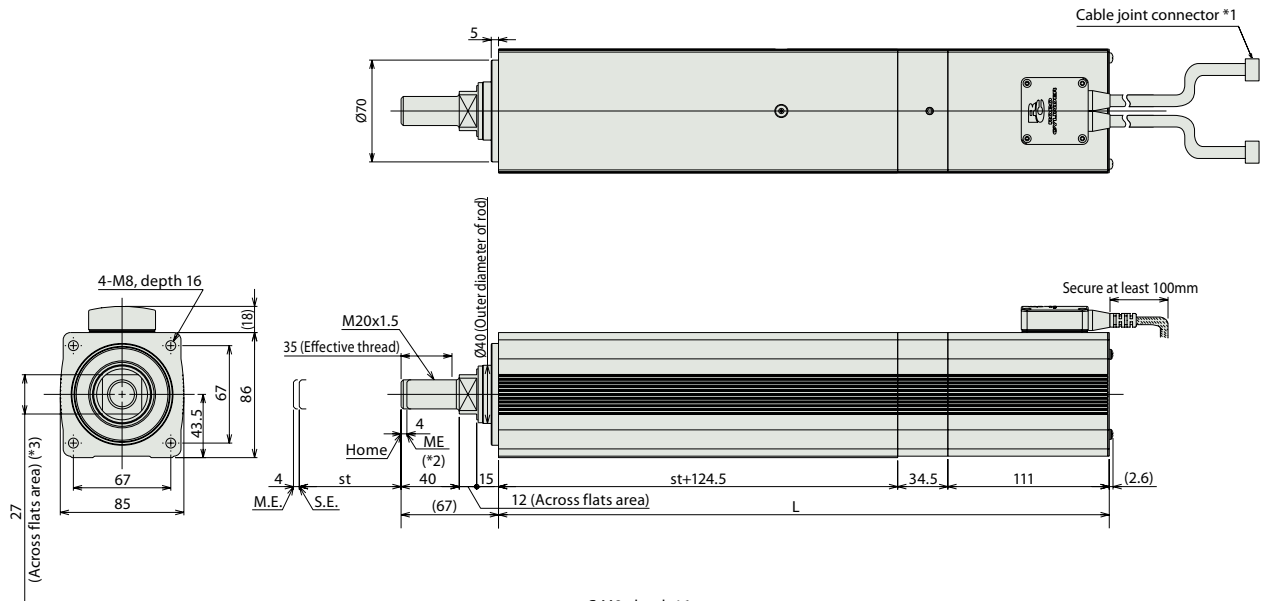

Dimensions of flange type

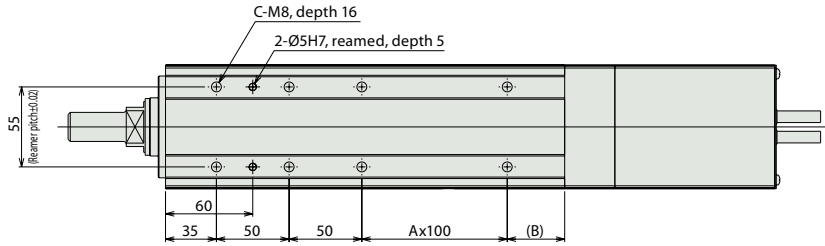
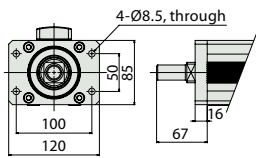

Dimensions of foot bracket type

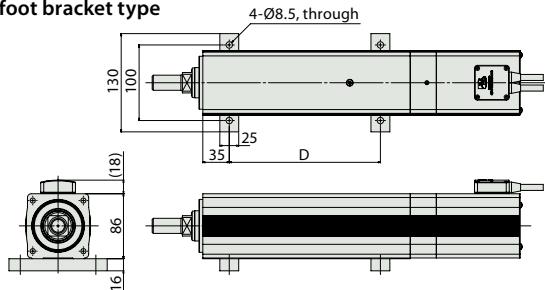

Dimensions of brake type

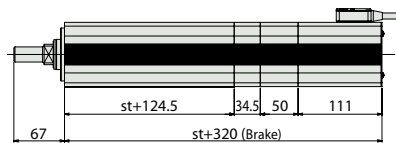

- *1. Connect the motor/encoder cables.
- *2. During home return, the rod will move all the way to the ME. Accordingly, pay attention to prevent possible contact between the rod and surrounding parts during home return.
ME: Mechanical End SE: Stroke End
Reference dimensions are shown in parentheses.
- *3. The orientation of the bolt will vary depending on the product.

Dimensions by Stroke (mm)

Stroke	50	100	150	200	250	300	
L	320	370	420	470	520	570	
A	0	0	1	1	2	2	
B	39.5	89.5	39.5	89.5	39.5	89.5	
C	6	6	8	8	10	10	
D	100	100	200	200	300	300	
Mass (kg)	No brake	6.5	7.4	8.2	9.1	9.9	10.7
	Brake-equipped	7.5	8.4	9.2	10.1	10.9	11.7

Dimensions

RA8R

Note

Do not apply an external force to the rod from any direction other than the moving direction of the rod. If a force is applied to the rod from the direction perpendicular to the rod or rotating direction of the rod, the stopper may be damaged.

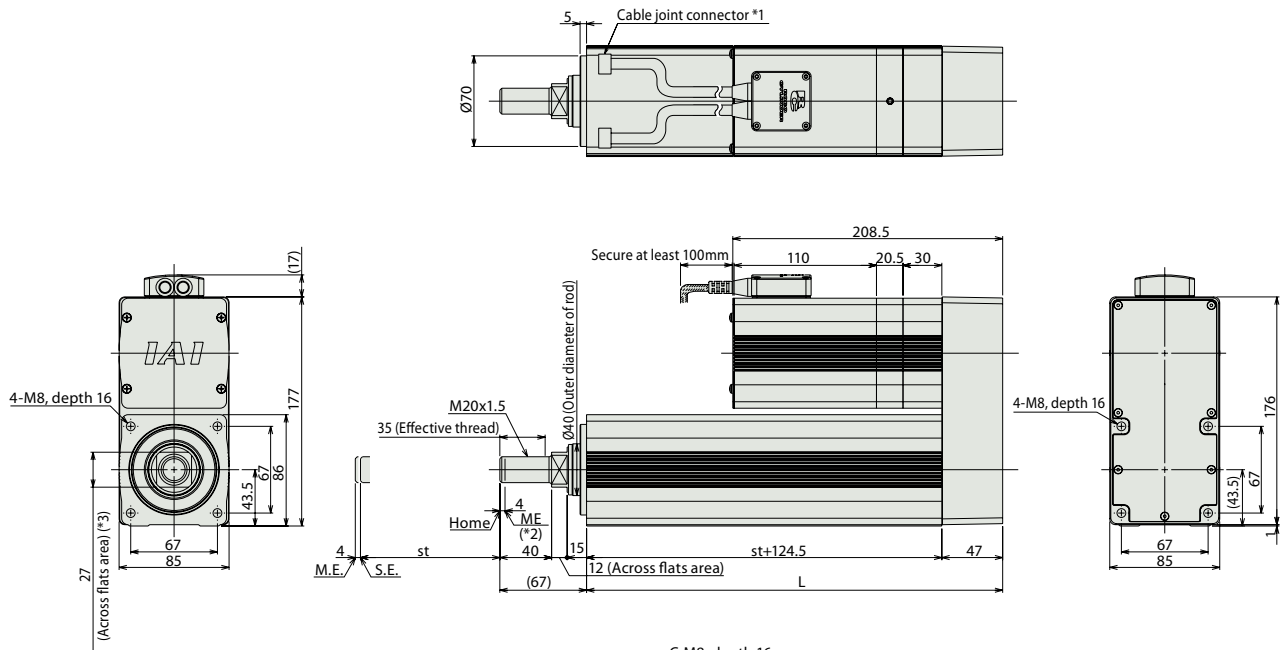

Dimensions of flange type

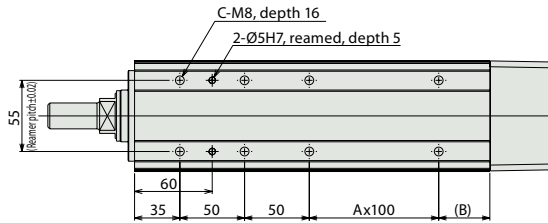
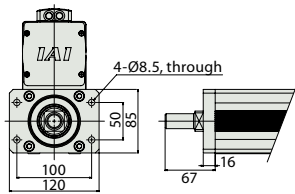

Dimensions of foot bracket type

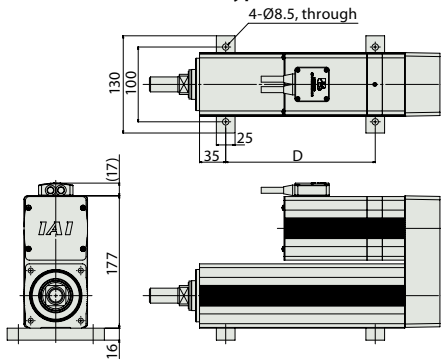

Dimensions of brake type

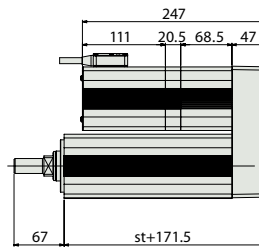

- *1. Connect the motor/encoder cables.
- *2. During home return, the rod will move all the way to the ME. Accordingly, pay attention to prevent possible contact between the rod and surrounding parts during home return.
ME: Mechanical End SE: Stroke End
Reference dimensions are shown in parentheses.
- *3. The orientation of the bolt will vary depending on the product.

Dimensions by Stroke (mm)

Stroke	50	100	150	200	250	300	
L	221.5	271.5	321.5	371.5	421.5	471.5	
A	0	0	1	1	2	2	
B	39.5	89.5	39.5	89.5	39.5	89.5	
C	6	6	8	8	10	10	
D	100	100	200	200	300	300	
Mass (kg)	No brake	7.7	8.6	9.4	10.3	11.1	12
	Brake-equipped	8.6	9.5	10.3	11.2	12.0	12.9

Selection Guide (Correlation Diagrams of Speed and Payload)

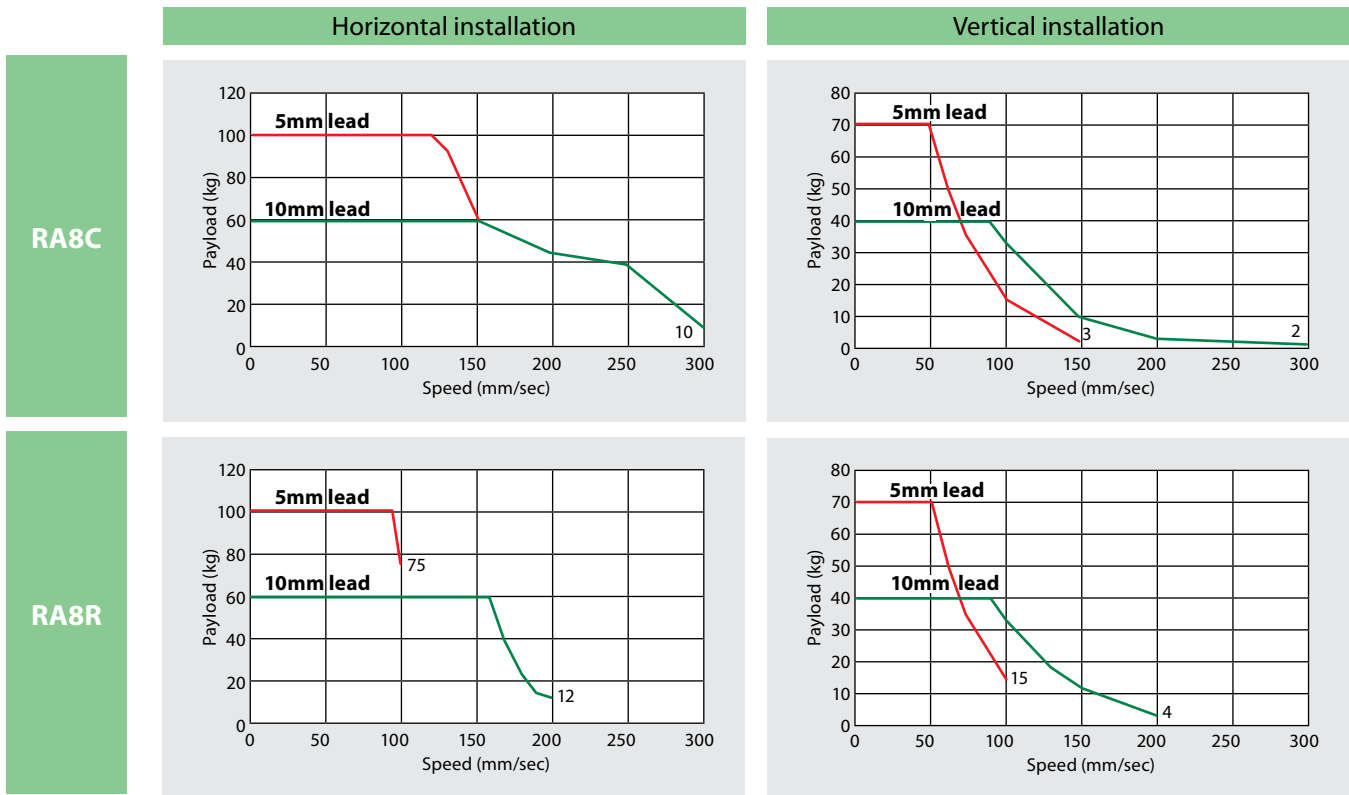

Selection Guide (Push Force and Current Limiting Value Correlation Diagram)

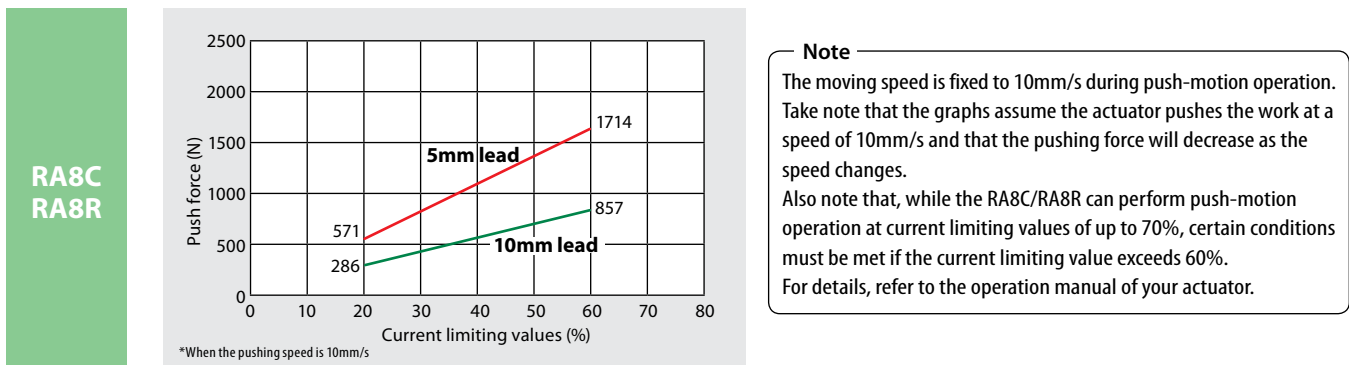

Notes

1. Life

Rod-type ROBO Cylinder® actuators have a service life of 5,000km, but the RCP2-RA8C/RA8R types with a lead of 5 may have a shorter service life depending on the payload because the applicable thrust is higher. Check the relationship of payload and service life for your actuator on the graph shown to the right.

Relationship of payload and service life (lead 5, used vertically)

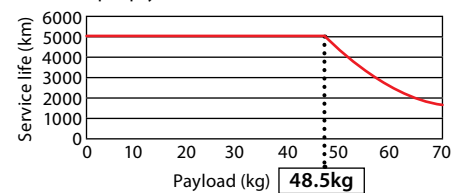

2. External Force on the Rod

Do not apply an external force to the rod from any direction other than the moving direction of the rod. If a force is applied to the rod from the direction perpendicular to the rod or rotating direction of the rod, the stopper may be damaged.



3. Run-out of the Rod

With the standard rod types, the run-out at the tip of the rod is not considered. If there is a noticeable run-out of the rod, use an external guide.

IAI America, Inc.

Headquarters: 2690 W. 237th Street Torrance, CA 90505 (800) 736-1712

Chicago Office: 1261 Hamilton Parkway Itasca, IL 60143 (800) 944-0333

Atlanta Office: 1220 Kennestone Circle, Suite 108, Marietta, GA 30066 (888) 354-9470

IAI Industrieroboter GmbH

Ober der Roth 4, D-65824 Schwalbach am Taunus, Germany

www.intelligentactuator.com



The information contained in this product brochure may change without prior notice due to product improvements.