

ROBO Cylinder 3-Finger Gripper, Lever Type

RCP2-GR3LS/GR3LM

ROBO Cylinder 3-Finger Gripper, Slide Type

RCP2-GR3SS/GR3SM

Securely gripping circular and cylindrical load!
New electrical 3-Finger grippers
also allow for easy adjustment
of gripping force!



Features

- Three fingers facilitate centering of load**
 The load can be centered easily as the three fingers grip the load simultaneously.
- High gripping force from a compact body**
 The unique drive method using a worm gear produces a high gripping force from a compact body.
- Two types for different applications**
 Choose the "lever type" that offers a wide open/close range while achieving high-speed operation, or the "slide type" that generates a high gripping force while ensuring excellent rigidity.
- Maintains the gripping force even after the power is off**
 The self-lock mechanism maintains the current position even after the power is switched off, so the load will not fall in the event of sudden power failure.

Example of Use

Combine with a SCARA robot to transfer cylindrical load.

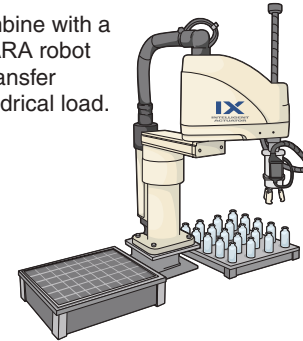

Model

Actuator Model

RCP2	GR3LS	I	PM	30	19	P1	M	SB
Series	Type code	Encoder type	Motor type	Gear ratio	Stroke	Applicable controller	Cable length	Options
RCP2	GR3LS: Lever type (S size) GR3LM: Lever type (M size) GR3SS: Slide type (S size) GR3SM: Slide type (M size)	I: Incremental	PM: Pulse motor	30: Gear ratio 1/30	GR3LS:19° GR3LM:19° GR3SS:10mm GR3SM:14mm	P1:RCP2-C RCP2-CG	N: No cable P:1m S:3m M:5m X: Specified length R: Robot cable	SB: Shaft bracket FB: Flange bracket

Options (Actuator brackets)

A bracket is used to install the gripper body. You can choose the shaft type or flange type according to the shape of the installation surface.

Shaft Bracket

- For GR3LS/GR3SS
Unit model: RCP2-SB-GR3S

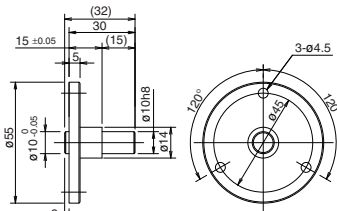

- For GR3LM/GR3SM
Unit model: RCP2-SB-GR3M

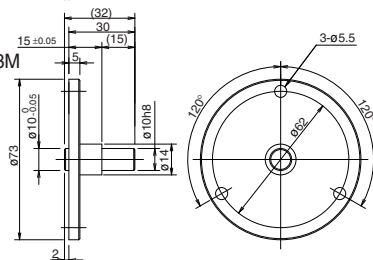

Flange Bracket

- For GR3LS/GR3SS
Unit model: RCP2-FB-GR3S

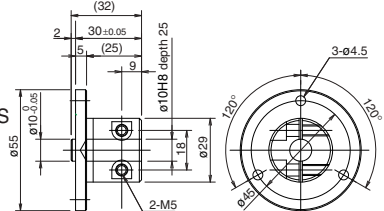

- For GR3LM/GR3SM
Unit model: RCP2-FB-GR3M

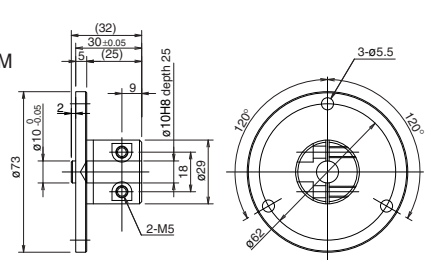

RCP2-GR3LS/GR3LM

3-Finger gripper, lever type
Actuator width: 62 mm/80 mm, pulse motor



Type Grip (Width: 62 mm/80 mm) Stroke 19° Maximum gripping force 18N/51N

Model specification items Series Type Encoder type Motor output Gear ratio Stroke Applicable controller Cable Option
(Example) RCP2-GR3LS- I - PM - 30 - 19 - P1 - M - SB

Model / Specifications

Model	Size	Encoder type	Motor type	Gear ratio	Stroke (°)	Open/close stroke (one side) (°)	Maximum open/close speed (one side) (Note 1) (°/sec)	Maximum gripping force (Note 2) (N)
RCP2-GR3LS-I-PM-30-19-P1-①-②	S size	Incremental	Pulse motor	30	19	-14°~5°	200	18
RCP2-GR3LM-I-PM-30-19-P1-①-②	M size							51

* ① and ② in the model numbers shown above respectively indicate the cable length and applicable options.

Options

Name	Code	Page
Shaft bracket	SB	Cover
Flange bracket	FB	Cover

Common Specifications

Drive system	Worm gear + Worm wheel gear
Positioning repeatability (Note 3)	±0.01°
Backlash	1° max. per side (Pressure is constantly applied toward the open side via spring.)
Base	Material: Aluminum with white alumite treatment
Cable length (Note 4)	N: No cable, P: 1 m, S: 3 m, M: 5 m, X □ Specified length, R □ Robot cable
Weight	GR3LS:0.6kg/GR3LM:1.1kg
Operating temperature/humidity	0 to 40°C, 85%RH max. (non-condensing)

Dimensions

GR3LS (Lever type, S size)

* During home return the actuator will return home along a path running 1° outside of the shortest line home, so be careful to prevent contact with surrounding parts.

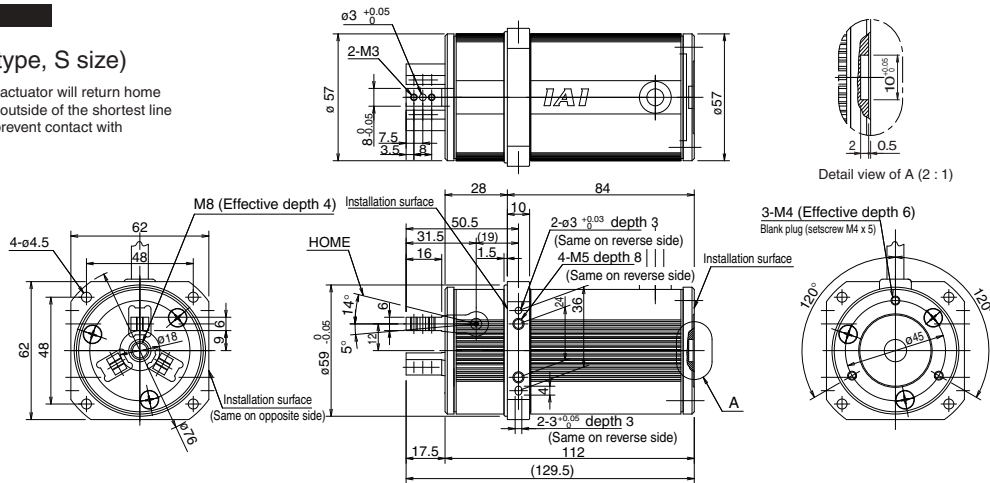

GR3LM (Lever type, M size)

* During home return the actuator will return home along a path running 1° outside of the shortest line home, so be careful to prevent contact with surrounding parts.

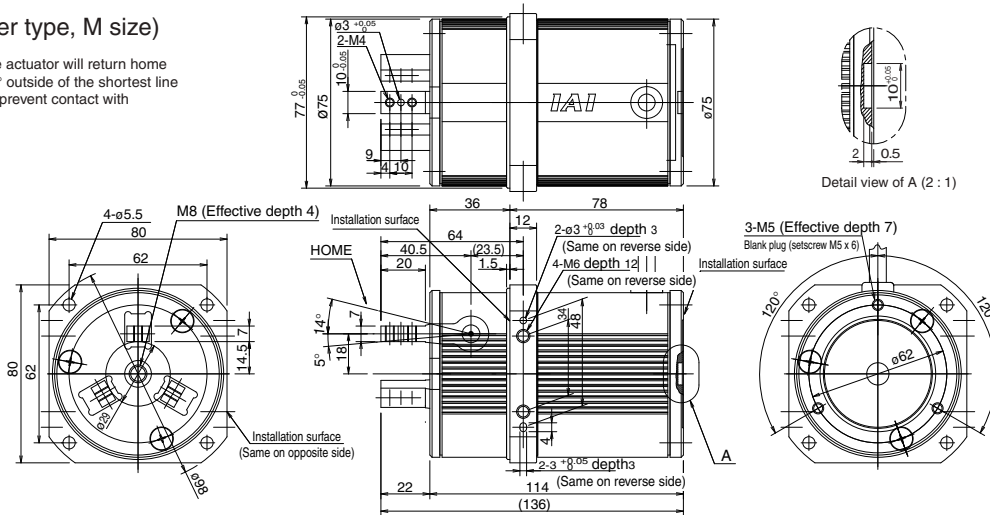

Applicable Controller Specification

Applicable controller	Maximum number of controlled axis	Compatible encoder type	Program operation	Power-supply voltage	Page
RCP2-C-GR3LS/GR3LM	1 axis	Incremental	Positioner	24VDC	Back cover
RCP2-CG-GR3LS/GR3LM					



Caution

(Note 1) The speed when one side (finger) of the grippers is operated. The relative operating speed is twice this value.
(Note 2) The sum of gripping forces of all fingers when the gripping-point distance is 10 and overhang distance is 0. The actual allowable gripping force will vary depending on the applicable conditions. Refer to the back cover for details.
(Note 3) Positioning repeatability of positioning operations from the negative direction.
(Note 4) The maximum cable length is 20 m. Specify the desired length in meters (e.g., X08 = 8 m).

RCP2-GR3SS/GR3SM

3-Finger gripper, Slide type
Actuator width: 62 mm/80 mm, pulse motor



Type Grip (Width: 62 mm/80 mm) Stroke 5mm/7mm Maximum gripping force 22N/102N

Model specification items Series Type Encoder type Motor output Gear ratio Stroke Applicable controller Cable Option
(Example) RCP2-GR3SS- I - PM - 30 - 10 - P1 - M - SB

Model / Specifications

Model	Size	Encoder type	Motor type	Gear ratio	Stroke (mm)	Open/close stroke (one side) (mm)	Maximum open/close speed (one side) (Note 1) (mm/sec)	Maximum gripping force (Note 2) (N)
RCP2-GR3SS-I-PM-30-10-P1-1-2	S size	Incremental	Pulse motor	30	10	5	40	22
RCP2-GR3SM-I-PM-30-14-P1-1-2	M size				14	7	50	102

* 1 and 2 in the model numbers shown above respectively indicate the cable length and applicable options.

Options

Name	Code	Page
Shaft bracket	SB	Cover
Flange bracket	FB	Cover

Common Specifications

Drive system	Worm gear + Worm wheel gear
Positioning repeatability (Note 3)	±0.01mm
Backlash	0.3 mm or less each side (The grippers are always kept open by a spring.)
Guide	Cross roller guide
Allowable load moment	<GRSS> Ma:3.8N·m / Mb:3.8N·m / Mc:3.0N·m <GRSM> Ma:6.3N·m / Mb:6.3N·m / Mc:5.7N·m
Base	Material: Aluminum with white alumite treatment
Cable length (Note 4)	N: No cable, P: 1 m, S: 3 m, M: 5 m, X : Specified length, R : Robot cable
Weight	GR3SS:0.6kg / GR3SM:1.2kg
Operating temperature/humidity	0 to 40°C, 85%RH max. (non-condensing)

Dimensions

GR3SS (Slide type, S size)

* During home return the actuator will return home along a path running 0.5 mm outside of the shortest line home, so be careful to prevent contact with surrounding parts.

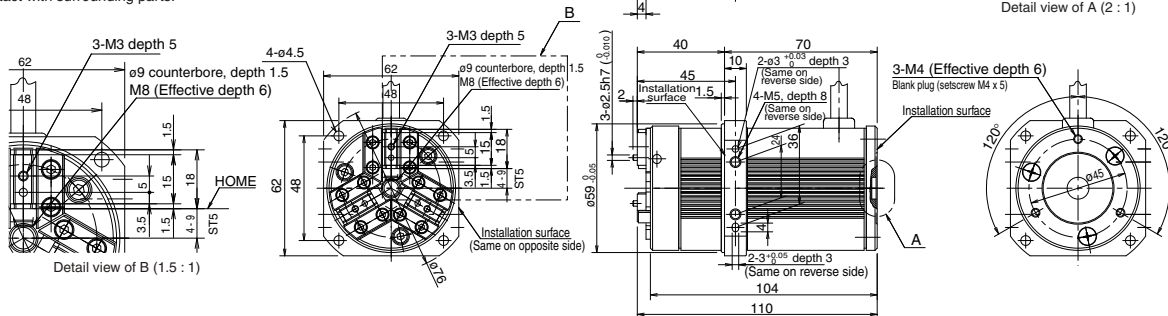

GR3SM (Slide type, M size)

* During home return the actuator will return home along a path running 0.5 mm outside of the shortest line home, so be careful to prevent contact with surrounding parts.

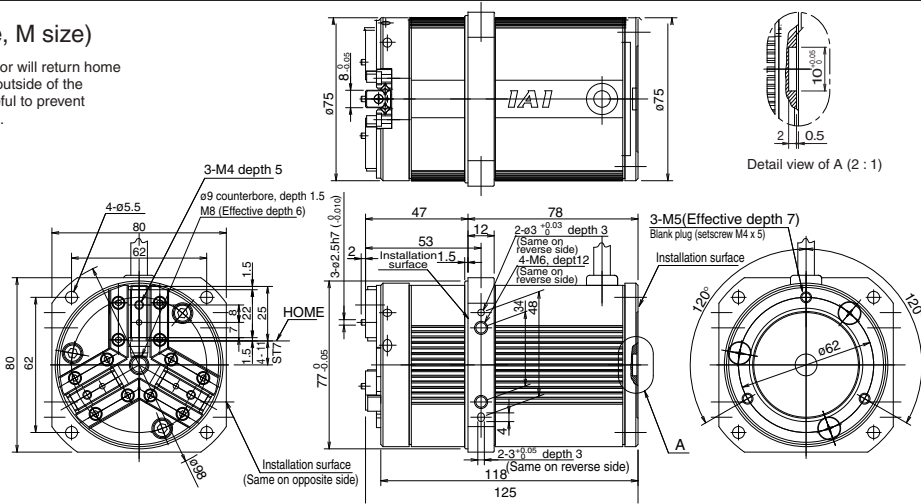

Applicable Controller Specification

Applicable controller	Maximum number of controlled axis	Compatible encoder type	Program operation	Power-supply voltage	Page
RCP2-C-GR3SS/GR3SM	1 axis	Incremental	Positioner	24VDC	Back cover
RCP2-CG-GR3SS/GR3SM					



Caution

(Note 1) The speed when one side (finger) of the grippers is operated. The relative operating speed is twice this value.
(Note 2) The sum of gripping forces of all fingers when the gripping-point distance is 0 and overhang distance is 0. The actual allowable gripping force will vary depending on the applicable conditions. Refer to the back cover for details.
(Note 3) Positioning repeatability of positioning operations from the negative direction.
(Note 4) The maximum cable length is 20 m. Specify the desired length in meters (e.g., X08 = 8 m).

Controller

Model / Specifications

Controller Model

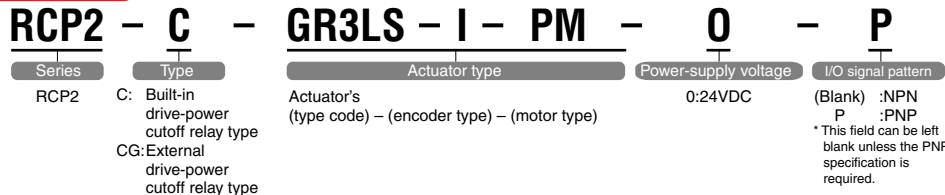

Specification Table

Item	Specification
Controller series/type	RCP2-C/CG
Connected actuator	RCP2 Series
Input power supply	24 VDC ± 10%
Power-supply capacity	2 A max.
Number of controlled axis	1 axis
Control method	Field-weakening vector control (patent pending)
Positioning command	Position number specification
Position numbers	Standard 16 points, maximum 64 points
Backup memory	Storage of position number data and parameters in non-volatile memory. Serial E2PROM rewritable up to 100,000 times.
PIO	RCP2-C (CG): 10 dedicated inputs (10 points) / 11 dedicated outputs (10 points); selectable from 5 patterns
LED indicators	RDY (green), RUN (green), ALM (red)
I/F power supply	External power supply: 24 V ± 10%, 0.3 A; insulated
Communication	RS485, 1 channel (terminated externally)
Withstand voltage	500 VDC, 10 MΩ
Operating temperature	0 to 40°C
Operating humidity	85%RH max. (non-condensing)
Operating ambience	Free from corrosive gases
Weight	300g
Accessory	PIO flat cable (2 m)

External Dimensions

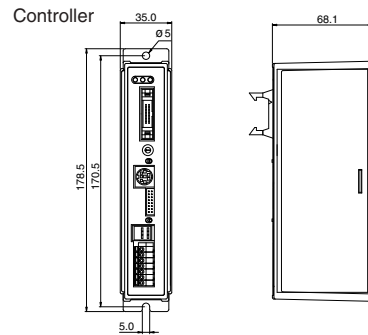

Options/Spare Parts

Item	Model
Teaching pendant	RCA-T
Teaching pendant (deadman specification)	RCA-TD
Simple teaching pendant	RCA-E
Data setting unit	RCA-P
PC software	RCB-101-MW
Motor cable	CB-RCP2-MA □□□
Encoder cable	CB-RCP2-PA □□□
Encoder robot cable	CB-RCP2-PA □□□ -RB

* The standard motor cable is a robot cable.

Correlation Diagrams of Gripping Force and Current-limiting Value

Lever type (GR3LS/GR3LM)

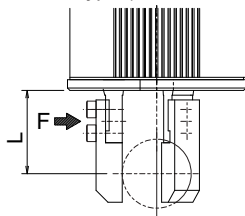

* The graphs below show gripping forces measured at a 10-mm point. The actual gripping force will decrease in inverse proportion to the distance from the open/close fulcrum.

Calculate the actual gripping force using the formula below:
 Effective gripping force (S type) = $P \times 24 / (L + 14)$
 Effective gripping force (M type) = $P \times 28.5 / (L + 18.5)$
 P = Gripping force in the graph
 L = Distance from the finger installation surface to the gripping point

Slide type (GR3SS/GR3SM)

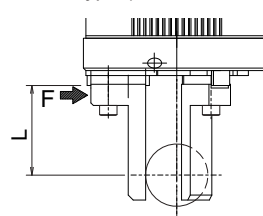

* The distance (L) from the finger installation surface to the gripping point must not exceed the following dimensions:
 GR3SS 50 mm or less
 GR3SM 80 mm or less

