

# PowerCON SCARA **IXP** Series

## Program Controllers for PowerCON SCARA **MSEL-PCX/PGX**

**Series Added**

Class 10

Cleanroom specification

IP65

Dust/Splash-proof specification



# Cleanroom specification and Dust/Splash-proof specification Added in Cost-effective IXP Series Giving More Variations to the Lineup

All models come standard with battery-less absolute encoders.



1

## All models come standard with high resolution battery-less absolute encoders.

All models come standard with battery-less absolute encoders that do not require batteries. Since battery replacement is no longer necessary, maintenance labor is reduced. In addition, the encoder resolution has increased 10 times compared to the conventional IXP series.

### Advantages of Battery-less Absolute Encoders

- The SCARA will not stop due to battery errors (low voltage, etc.)
- No cost of battery replacement
- No need for absolute reset or other physical tasks associated with battery replacement

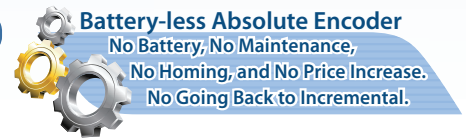

**Battery-less Absolute Encoder**  
No Battery, No Maintenance,  
No Homing, and No Price Increase.  
No Going Back to Incremental.

2

## More Affordable Due to Pulse Motors

Equipped with a pulse motor for Power-Con with IAI's own technology

**...the IXP costs around 1/2 of conventional model.**

\* Compared against an IAI robot based on an arm length of 350mm.

SCARA robot 3-axis specification enables you to reduce the cost by up to about 15%. The IXP achieves a payload equivalent to that of a conventional model by adopting high-output drivers.

3

## Lighter than IX Series

**The robot weighs approx. 30% less.**

(Compared to: IX-NNN3515H)

The lightweight robot can be easily assembled into your system.

	IX Series		IXP Series
Model	IX-NNN2515H		IXP-4N2508
Mass	17.1kg	<b>-9.1kg</b> →	<b>8kg</b>
Model	IX-NNN3515H		IXP-4N3515
Mass	18kg	<b>-5kg</b> →	<b>13kg</b>
Model	IX-NNN50□□H		IXP-4N5520
Mass	29.5kg	<b>-8.5kg</b> →	<b>21kg</b>

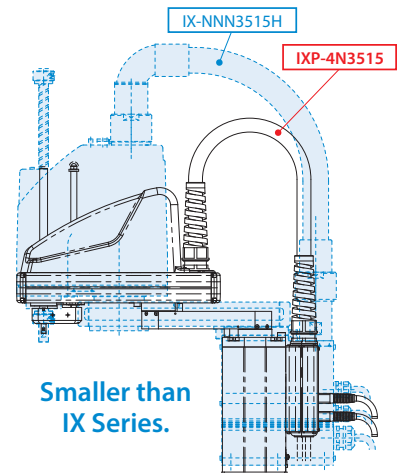

1

# 4

## Added 3-axis Specification and 4-axis\* Gripper Specification

The 3-axis specification has no rotational axis for greater allowable load moment of inertia. It can be combined with a dedicated gripper to constitute a transfer robot with ease.

\*The gripper type has four axes including three SCARA robot axes and one gripper axis. There is no 4-axis type equipped with gripper provided for Arm Length 180 Type.

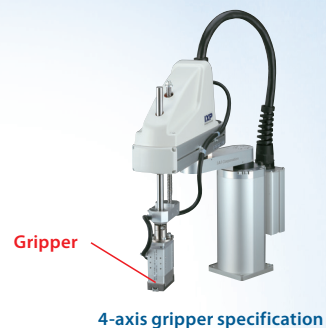

### Use Examples of the 3-axis Specification

● Work processes that require only three axes

- ➔ Pickup and placement of circular parts, non-directional transfer, etc.

#### Inspecting cans for defects

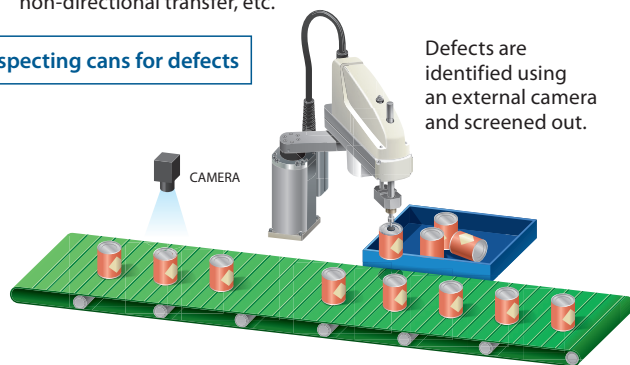

● Connecting an actuator as the fourth axis

A ROBO Cylinder of a rotary type, rod type, slider type, etc., can be connected to a SCARA robot 3-axis specification as its fourth axis.

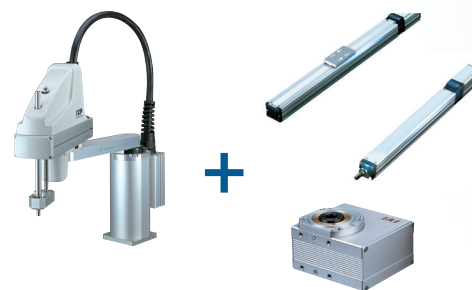

# 5

## Added Cleanroom specification and Dust/Splash-proof specification

Added Cleanroom specifications and Dust/Splash-proof to arm length 350mm/450mm/550mm/650mm.

You can choose the optimal product from extensive lineups.

#### Cleanroom class 10

Class 10 (0.5 μm) refers to an environment with less than 10 particles of 0.5 μm or more in 1 cubic foot. (Fed. Std. 209 D)

#### Cleanroom class 3.5

Represented with an exponent when the number of particles of 0.1 μm or more in 1 m is represented by a power of 10. (ISO 14644-1)

Cleanroom class 10

Cleanroom class 3.5

IP65

IP65	Solid foreign substance	(Summary) Dust-proof type *Dust is completely blocked and does not penetrate inside the body.
	Water	(Summary) Protect against water jet. Even if it receives direct water jet from any direction, it will not be harmfully affected.

※JIS C 0920

# 6

## Supporting MSEL Controller

### ① Accommodating Significantly More Programs and Positions

The greater storage capacity accommodates significantly more programs and positions.

	MSEL (New product)	XSEL-PX (Conventional product)
Number of programs	255	128
Number of positions	30,000	20,000

### ② Smaller Size

Having a size of 130mm in width x 195mm in height, the MSEL is significantly smaller than a conventional controller and saves space in your control panel.

The MSEL can be installed with screws or using a DIN rail.

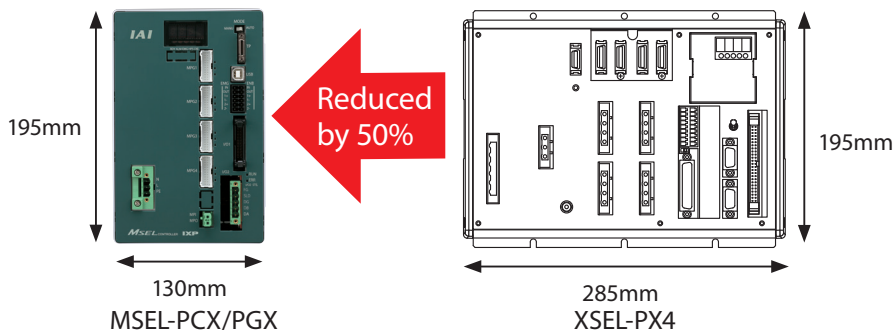

## Product Lineup

### Standard specification

Arm length	180mm		250mm	
Number of axes	3-axis	4-axis (with rotational axis)	3-axis	4-axis (with rotational axis)
Without gripper	IXP-3N1808	IXP-4N1808	IXP-3N2508	IXP-4N2508
Payload	Rated 1kg , Maximum 3kg		Rated 1kg , Maximum 3kg	
Standard price	–	–	–	–
With medium gripper Gripper model code: RCP4-GRSML	–	–	IXP-3N2508GM	–
Payload			Maximum 0.5kg *1	
Standard price			–	

Arm length	350mm		450mm	
Number of axes	3-axis	4-axis (with rotational axis)	3-axis	4-axis (with rotational axis)
Without gripper	IXP-3N3515	IXP-4N3515	IXP-3N4515	IXP-4N4515
Payload	Rated 1kg , Maximum 3kg		Rated 1kg , Maximum 3kg	
Standard price	–	–	–	–
With medium gripper Gripper model code: RCP4-GRSML	IXP-3N3515GM	–	IXP-3N4515GM	–
Payload	Maximum 0.5kg *1		Maximum 0.5kg *1	
Standard price	–		–	
With large gripper Gripper model code: RCP4-GRSLL	IXP-3N3510GL	–	IXP-3N4510GL	–
Payload	Maximum 1.5kg *1		Maximum 1.5kg *1	
Standard price	–		–	

Arm length	550mm		650mm	
Number of axes	3-axis	4-axis (with rotational axis)	3-axis	4-axis (with rotational axis)
Without gripper	IXP-3N5520	IXP-4N5520	IXP-3N6520	IXP-4N6520
Payload	Rated 2kg , Maximum 6kg		Rated 2kg , Maximum 6kg	
Standard price	–	–	–	–
With large gripper Gripper model code: RCP4-GRSLL	IXP-3N5515GL	–	IXP-3N6515GL	–
Payload	Maximum 1.5kg *1		Maximum 1.5kg *1	
Standard price	–		–	
With extra-large gripper Gripper model code: RCP4-GRSWL	IXP-3N5515GW	–	IXP-3N6515GW	–
Payload	Maximum 2.5kg *1		Maximum 2.5kg *1	
Standard price	–		–	

\*1: This is the maximum payload. The payload may differ in some conditions of use. Refer to the gripper selection guide in our ROBO Cylinder General Catalog.



## Cleanroom specification

Arm length	350mm		450mm	
Number of axes	3-axis	4-axis (with rotational axis)	3-axis	4-axis (with rotational axis)
Model	IXP-3C3515	IXP-4C3515	IXP-3C4515	IXP-4C4515
Payload	Rated 1kg , Maximum 3kg		Rated 1kg , Maximum 3kg	
Clean class	Class 10 (Fed. Std. 209D)		Class 10 (Fed. Std. 209D)	
	Equivalent to Class 3.5 (ISO 14644-1)		Equivalent to Class 3.5 (ISO 14644-1)	
Standard price	–	–	–	–

Arm length	550mm		650mm	
Number of axes	3-axis	4-axis (with rotational axis)	3-axis	4-axis (with rotational axis)
Model	IXP-3C5520	IXP-4C5520	IXP-3C6520	IXP-4C6520
Payload	Rated 2kg , Maximum 6kg		Rated 2kg , Maximum 6kg	
Clean class	Class 10 (Fed. Std. 209D)		Class 10 (Fed. Std. 209D)	
	Equivalent to Class 3.5 (ISO 14644-1)		Equivalent to Class 3.5 (ISO 14644-1)	
Standard price	–	–	–	–

## Dust/Splash-proof specification

Arm length	350mm		450mm	
Number of axes	3-axis	4-axis (with rotational axis)	3-axis	4-axis (with rotational axis)
Model	IXP-3W3515	IXP-4W3515	IXP-3W4515	IXP-4W4515
Payload	Rated 1kg , Maximum 3kg		Rated 1kg , Maximum 3kg	
Protection class	IP65		IP65	
Standard price	–	–	–	–

Arm length	550mm		650mm	
Number of axes	3-axis	4-axis (with rotational axis)	3-axis	4-axis (with rotational axis)
Model	IXP-3W5520	IXP-4W5520	IXP-3W6520	IXP-4W6520
Payload	Rated 2kg , Maximum 6kg		Rated 2kg , Maximum 6kg	
Protection class	IP65		IP65	
Standard price	–	–	–	–

# Explanation of the Model Items

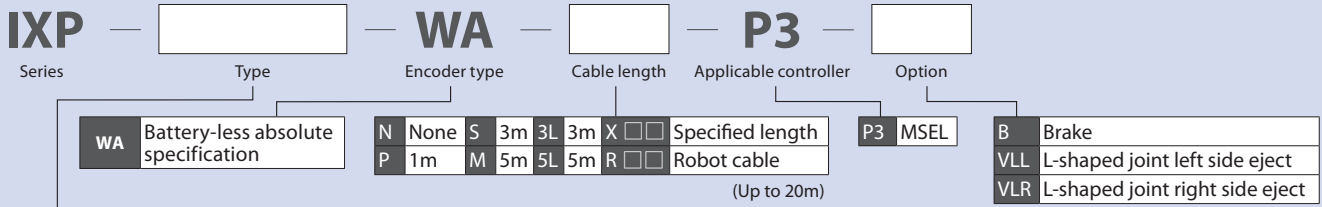

3N1808	3-axis type / Arm length 180mm / Vertical axis 80mm
4N1808	4-axis type / Arm length 180mm / Vertical axis 80mm
3N2508	3-axis type / Arm length 250mm / Vertical axis 80mm
4N2508	4-axis type / Arm length 250mm / Vertical axis 80mm
3N2508GM	3-axis type / Arm length 250mm / Vertical axis 80mm / RCP4-GRSML installed at the tip of the vertical axis
3N3515	3-axis type / Arm length 350mm / Vertical axis 80mm
4N3515	4-axis type / Arm length 350mm / Vertical axis 150mm
3N3515GM	3-axis type / Arm length 350mm / Vertical axis 150mm / RCP4-GRSML installed at the tip of the vertical axis
3N3510GL	3-axis type / Arm length 350mm / Vertical axis 100mm / RCP4-GRSLL installed at the tip of the vertical axis
3N4515	3-axis type / Arm length 450mm / Vertical axis 150mm
4N4515	4-axis type / Arm length 450mm / Vertical axis 150mm
3N4515GM	3-axis type / Arm length 450mm / Vertical axis 150mm / RCP4-GRSML installed at the tip of the vertical axis
3N4510GL	3-axis type / Arm length 450mm / Vertical axis 100mm / RCP4-GRSLL installed at the tip of the vertical axis
3N5520	3-axis type / Arm length 550mm / Vertical axis 200mm
4N5520	4-axis type / Arm length 550mm / Vertical axis 200mm
3N5515GL	3-axis type / Arm length 550mm / Vertical axis 150mm / RCP4-GRSLL installed at the tip of the vertical axis
3N5515GW	3-axis type / Arm length 550mm / Vertical axis 150mm / RCP4-GRSWL installed at the tip of the vertical axis
3N6520	3-axis type / Arm length 650mm / Vertical axis 200mm
4N6520	4-axis type / Arm length 650mm / Vertical axis 200mm
3N6515GL	3-axis type / Arm length 650mm / Vertical axis 150mm RCP4-GRSLL installed at the tip of the vertical axis
3N6515GW	3-axis type / Arm length 650mm / Vertical axis 150mm RCP4-GRSWL installed at the tip of the vertical axis
3C3515	Cleanroom specification 3-axis type / Arm length 350mm / Vertical axis 150mm
4C3515	Cleanroom specification 4-axis type / Arm length 350mm / Vertical axis 150mm
3C4515	Cleanroom specification 3-axis type / Arm length 450mm / Vertical axis 150mm
4C4515	Cleanroom specification 4-axis type / Arm length 450mm / Vertical axis 150mm
3C5520	Cleanroom specification 4-axis type / Arm length 550mm / Vertical axis 200mm
4C5520	Cleanroom specification 4-axis type / Arm length 550mm / Vertical axis 200mm
3C6520	Cleanroom specification 3-axis type / Arm length 650mm / Vertical axis 200mm
4C6520	Cleanroom specification 4-axis type / Arm length 650mm / Vertical axis 200mm
3W3515	Dust/Splash-proof specification 3-axis type / Arm length 350mm / Vertical axis 150mm
4W3515	Dust/Splash-proof specification 4-axis type / Arm length 350mm / Vertical axis 150mm
3W4515	Dust/Splash-proof specification 3-axis type / Arm length 450mm / Vertical axis 150mm
4W4515	Dust/Splash-proof specification 4-axis type / Arm length 450mm / Vertical axis 150mm
3W5520	Dust/Splash-proof specification 3-axis type / Arm length 550mm / Vertical axis 200mm
4W5520	Dust/Splash-proof specification 4-axis type / Arm length 550mm / Vertical axis 200mm
3W6520	Dust/Splash-proof specification 3-axis type / Arm length 650mm / Vertical axis 200mm
4W6520	Dust/Splash-proof specification 4-axis type / Arm length 650mm / Vertical axis 200mm

\*Only available for arm length 550/650.  
Make sure to select this when the transported object is 4kg or more.

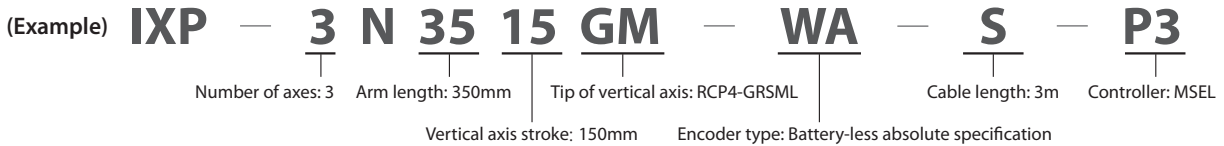

## Option

### L-shaped joint extraction direction

**Model** VLL / VLR

**Explanation**

You can select L-shaped joint for suction on the left side (model: VLL) or right side (model: VLR) for cleanroom specification.  
\*Please be sure to select either one.

# Applications

## Part Screening

Parts of two different sizes are classified using a sensor and sorted into different boxes.

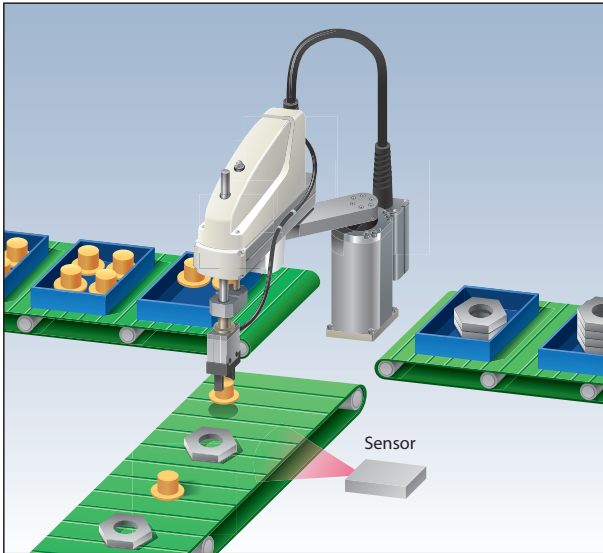

## Solar Battery Module Tab Soldering

Solar battery module cells are transferred while positions are adjusted so that electrodes can be soldered onto the cells.

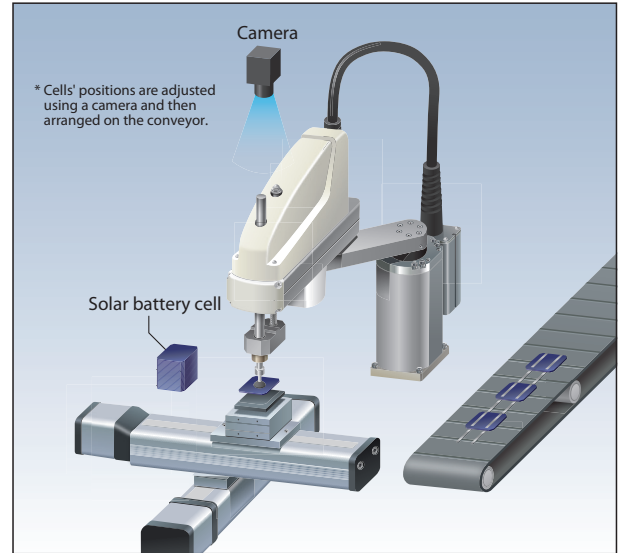

## DVD-R Packing

DVD-Rs are picked up from the conveyor and placed.

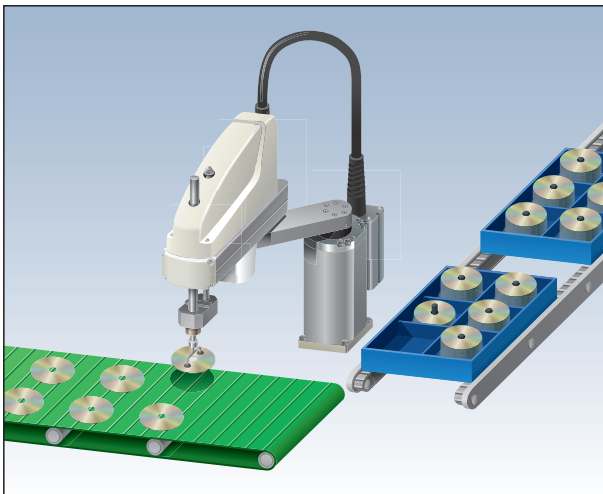

## Adhesive Application

Adhesive is applied onto circular parts.

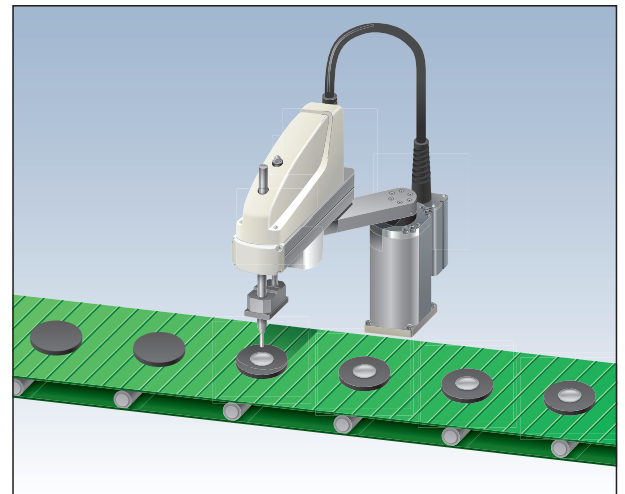

# Warnings

## (\*1) Positioning Repeatability

This refers to the degree to which the robot can accurately repeat the same target position when operated at the same speed, acceleration rate, and arm-type. (The values are measured at a constant room temperature of 20°C) Please note that this is not an absolute positioning accuracy. In addition, please be aware that the positioning accuracy may deviate in situations where the operating conditions have changed; for example switching the robot arms, changing from multiple opposing positions to one set position, or changing the operating speed and acceleration/deceleration rate.

## (\*2) Maximum Operating Speed for PTP Operation

The maximum operating speed in the specification table assumes PTP command operation. In the case of CP command operation (interpolation), there is a limit to the speed. For more details, please refer to the "CP Operation" section of the "Estimate of SCARA Robot Acceleration/Deceleration Settings" on p.8. In addition, please note that in order to operate the vertical axis at the lowest position, the speed and acceleration rate must be appropriately reduced as well.

## (\*3) Payload

The options are rated payload and maximum payload. The rated payload refers to the maximum load that can be transferred at the maximum speed and acceleration rate. The maximum payload refers to the load that can be transferred at a reduced speed and acceleration rate. When transporting a load that is greater than the rated payload, by programming the load and moment of inertia, the appropriate speed and acceleration rate will automatically be applied.

## (\*4) Standard Cycle Time

The standard cycle time is the round-trip operation times under the conditions outlined below. This is a general estimate of high-speed performance.

\*For gripper-equipped models, the weight of the gripper will also be included in the transported weight.

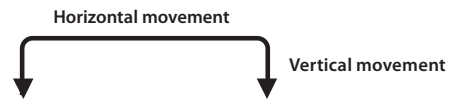

Arm length	Transferring weight(kg)	Horizontal movement distance(mm)	Vertical movement distance(mm)	Cycle time (sec)
180	1	100	25	0.57
250	1	300	25	0.79
350	1	300	25	0.69 (Standard specification) 0.76 (Clean /Dust/Splash-proof specification)
450	1	300	25	0.67 (Standard specification) 0.74(Clean /Dust/Splash-proof specification)
550	2	300	25	0.73 (Standard specification) 0.79(Clean /Dust/Splash-proof specification)
650	2	300	25	0.81 (Standard specification) 0.93(Clean /Dust/Splash-proof specification)

## (\*5) Allowable Inertial Moment from the Tip of the Vertical Axis

This is the allowable inertial moment calculated at the center of the rod on the v 3-axis type, and rotational axis for 4-axis type).

The offset value from the center of the rotational axis to the center of gravity of the load is shown below.

- Arm length 180/250 ... horizontal direction 20mm or less, vertical direction 50mm or less
- Arm length 350/450 ... horizontal direction 30mm or less, vertical direction 50mm or less
- 550/650 ... horizontal direction 30mm or less, vertical direction 50mm or less

If the standard payload is exceeded, it is necessary to reduce the horizontal offset value. Please refer to the instructions manual for details. Also, if a tool's center of gravity is away from the center of the axis-tip, it is necessary to reduce the speed and acceleration rate appropriately.

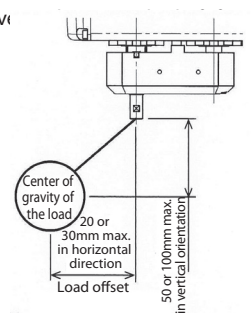

## (\*6) Overhang Limits for the Gripper Options

The overhang limit for gripper-equipped models (GM/GL/GW) is 0mm horizontally and 20mm or 50mm vertically from the gripper finger-tip to the piece's center of gravity. Please refer to the figure on the right.

- \*1 Arm length 250 ... 20mm
- Arm length 350/450/550/650 ... 50mm

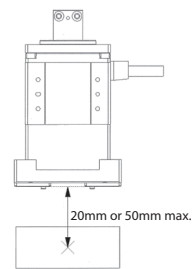

## Work Envelope

When switching arm orientation (left/right), please be careful that no peripheral objects interfere with the arm when fully extends.

## (\*7) Air suction inside the unit

In order to use the SCARA Cleanroom specification in clean class 10, the air in the unit must be sucked from the air suction port of the unit base. Please make piping that can flow the flow rate for each specification. Since the amount of dust are depending on the operating pattern, it is necessary to increase the amount of suction at high speed and high acceleration.

## (\*8) Air purge pressure

To use SCARA Dust/Splash-Proof specification with IP65, it is necessary to supply dry air (air purge) to a single air tube in the cable between controller and robot. Refer to the specification of each type for the air purge pressure. Please make piping that can flow the flow rate of each specification.

(\*1) to (\*8) are linked to notes in the product specifications pages (p. 9 through 36).



# SCARA Robot IXP Acceleration/Deceleration Settings Guide

If the robot must be operated continuously, make sure its setting falls within the ranges of the reference graphs for acceleration/deceleration setting and duty cycle setting.

## PTP Move

The maximum speed and acceleration/deceleration at which the robot can operate carrying the applicable load are applied as 100% (optimal speed & optimal acceleration/deceleration function). Make adjustments so that the target speed and acceleration/deceleration can be achieved.

### Notes

- The optimal speed & optimal acceleration/deceleration function does not guarantee robot operation in all operation patterns.
- If significant vibration generates, reduce the speed and/or acceleration/deceleration because the robot may fail or die prematurely.

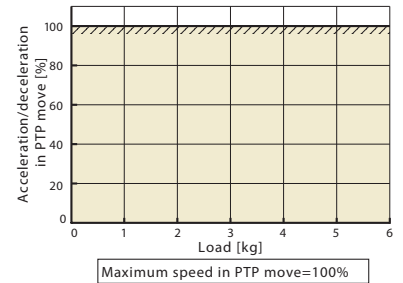

## CP Move

Set the speed and acceleration/deceleration at or below the applicable values according to the graphs below.

### Notes

- If significant vibration generates, reduce the speed and/or acceleration/deceleration because the robot may fail or die prematurely.

IXP-3/4N1808, 2508

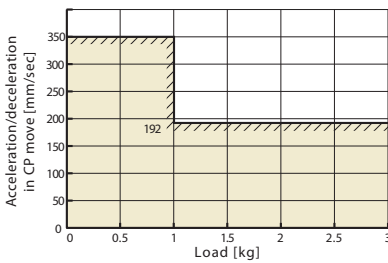

IXP-3/4N3515, 4515

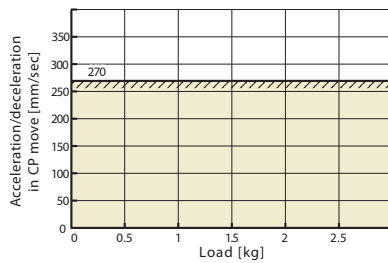

IXP-3/4N5520, 6520

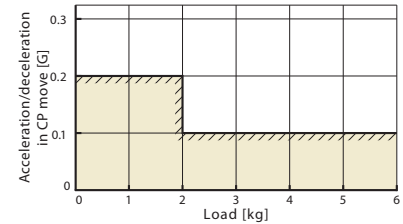
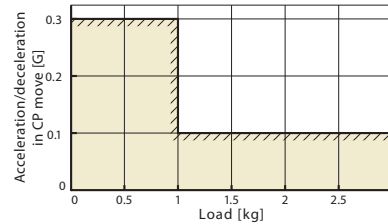
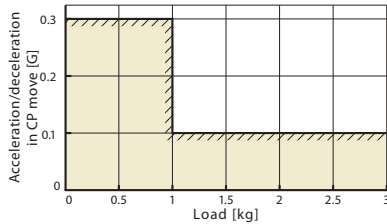
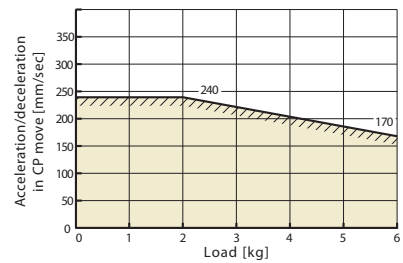

## Duty Cycle Setting

The duty cycle refers to a utilization ratio expressed by the percentage of the robot operating time per cycle.

For this robot, the duty cycle is limited according to the ambient temperature in order to suppress heat generation from the motor unit and reduction gears. In both PTP move and CP move, the maximum value according to the graphs below must not be exceeded. Also remember to complete a continuous operation within 30 minutes.

### Notes

- The duty cycle must not exceed the maximum limit, as it may significantly reduce the life of the motor unit or reduction gears.

IXP-3/4N1808, 2508

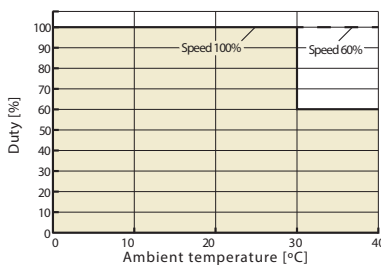

IXP-3/4N3515, 4515

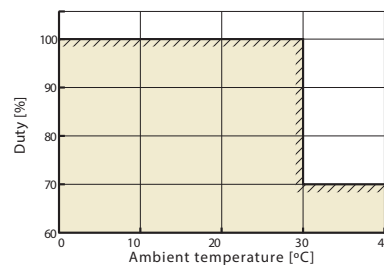

IXP-3/4N5520, 6520

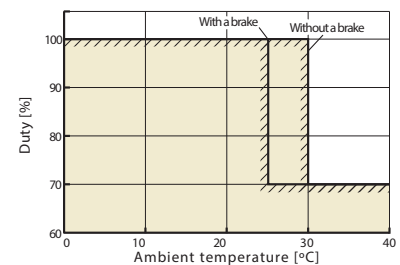

# IXP-3N1808/4N1808

Arm length  
**180mm**

Vertical axis  
**80mm**

Model Specification Items	<b>IXP</b>	—	<b>N</b>	—	<b>1808</b>	—	<b>WA</b>	—		—	<b>P3</b>
	Series		Number of axes 3: 3 axes 4: 4 axes	Arm length: 180mm Vertical axis: 80mm		Encoder type WA: Battery-less absolute specification	Cable length N: None P: 1m S: 3m M: 5m	X□□: Specified length R□□: Robot cable Cable length described below		Applicable controller P3: MSEL	

\*Controller is not included.



**POINT**  
Note on selection

- Refer to P. 7 for \*1 through \*6.
- There is a brake equipped on the vertical axis as a standard option.
- The vertical axis does not support push-motion control.
- The allowable push force should be 45N under condition of having a buffer such as a spring on a tool or the pressing side.
- Refer to P. 7 for the work envelope, and P. 8 for the notes on acceleration/deceleration setting.

## Robot Specifications

Axis configuration		Arm length (mm)	Work envelope	Positioning repeatability *1	Maximum operating speed in PTP mode *2	Payload (kg) *3	
						Rated	Maximum
Axis 1	Arm 1	80	±125°	±0.01mm	2053mm/s (Composite speed)	1	3
Axis 2	Arm 2	100	±125°				
Axis 3	Vertical axis	—	80mm	±0.02mm	350mm/s		
Axis 4	Rotational axis	—	±360°	±0.01°	1200°/s		

## Robot Specifications

	3-axis specification	4-axis specification
Encoder type	Battery-less absolute encoder	
User wiring	AWG26×8	
User piping	O.D. ø4, I.D. ø2.5, 2 air tubes Maximum working pressure 0.8MPa	
Standard cycle time *4 (sec)	0.57	
Allowable torque (Axis 4) (N·m)	—	0.28
Allowable moment (N·m)	0.7	
Allowable inertial moment from the tip of the vertical axis *5 (kg·m <sup>2</sup> )	Rated 0.001 Maximum 0.01	Rated 0.001 Maximum 0.003
Ambient operating temperature/humidity	Temperature 0 ~ 40°C, Humidity 20 ~ 85%RH (Non-condensing)	
Unit weight (kg)	7	7.5

## Price List

Specification	Model number	Standard price
3-axis specification	IXP-3N1808	—
4-axis specification	IXP-4N1808	—

## Cable Length <Per Axis\*>

Type	Cable code	Standard price
Standard type	P (1m)	—
	S (3m)	—
	M (5m)	—
Specified length	X06 (6m) ~ X10 (10m)	—
	X11 (11m) ~ X15 (15m)	—
	X16 (16m) ~ X20 (20m)	—
Robot cable	R01 (1m) ~ R03 (3m)	—
	R04 (4m) ~ R05 (5m)	—
	R06 (6m) ~ R10 (10m)	—
	R11 (11m) ~ R15 (15m)	—
	R16 (16m) ~ R20 (20m)	—

\*The 3-axis specification requires three cables, while 4-axis specification requires four cables.

Dimensions



CAD drawings can be downloaded from the website. [www.intelligentactuator.com](http://www.intelligentactuator.com)

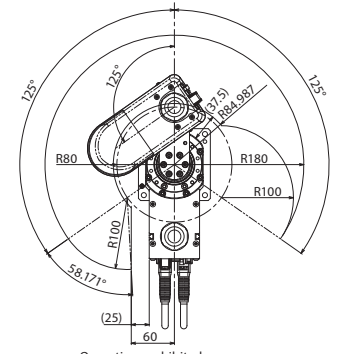
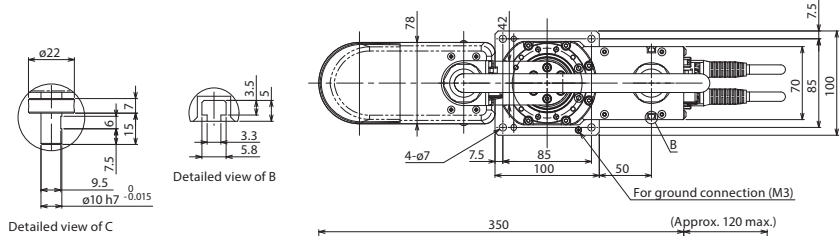

Operation prohibited area  
Work envelope of the right-arm system

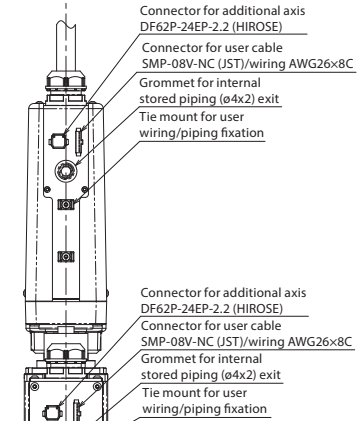
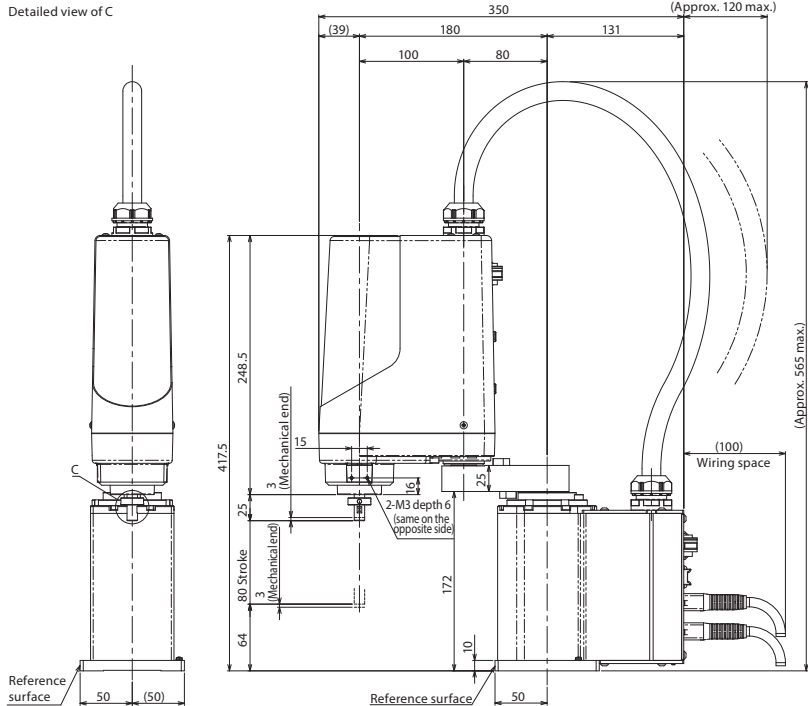

Connector for additional axis DF62P-24EP-2.2 (HIROSE)  
Connector for user cable SMP-08V-NC (JST)/wiring AWG26x8C  
Grommet for internal stored piping (ø4x2) exit  
Tie mount for user wiring/piping fixation

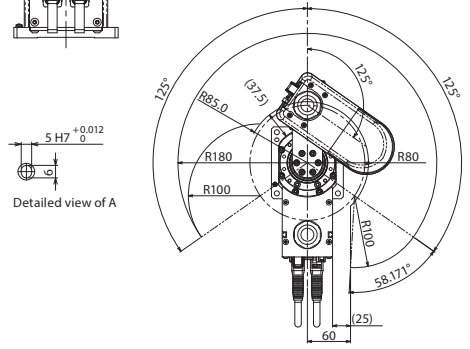

Operation prohibited area  
Work envelope of the left-arm system

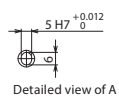
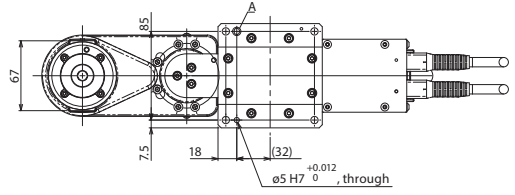

Detailed view of A

Applicable Controller

IXP series robots can operate with the following controllers. Make sure to select the model depending on the purpose.

Name	External view	Maximum number of controlled axes	Supply voltage	Control method				Max. pos. points	Standard price	Reference page
				Position	Pulse train	Program	Network *Option			
MSEL-PCX/PGX		4	Single-phase 100V ~ 230V	-	-	•	DeviceNet CC-Link EtherNet/IP PROFINET EtherCAT	30000	-	→P37

# IXP-3N2508/4N2508

Arm length **250mm**  
Vertical axis **80mm**

■ Model Specification Items	IXP	—	N	25	—	WA	—	P3
	Series	Number of axes 3: 3 axes 4: 4 axes	Arm length 25: 250mm	Vertical axis stroke 08 : 80mm 08GM : 80mm	Gripper Medium gripper installed *Refer to "Attached Gripper Types" for the types of grippers installed.	Encoder type WA: Battery-less absolute specification	Cable length N: None P: 1m S: 3m M: 5m	Applicable controller P3: MSEL

\*Controller is not included.



**POINT**  
Note on selection

- Refer to P. 7 for \*1 through \*6.
- There is a brake equipped on the vertical axis as a standard option.
- The vertical axis does not support push-motion control.
- The allowable push force is 45N under condition of having a buffer such as a spring on a tool or the pressing side.
- Refer to P. 7 for the work envelope, and P. 8 for the notes on acceleration/deceleration setting.

\*The photograph shows a 4-axis specification.

## Robot Specifications

Axis configuration	Arm length (mm)	Work envelope	Positioning repeatability*1	Maximum operating speed in PTP mode*2		Payload (kg) *3	
				No gripper	With medium gripper (GM)	Rated	Maximum
Axis 1	Arm 1	150	±0.02mm	2151mm/s (Composite speed)	2151mm/s (Composite speed)	1	3
Axis 2	Arm 2	100					
Axis 3	Vertical axis	—	±0.02mm	350mm/s	350mm/s	—	0.5 (Note 2)
Axis 4	Rotational axis	—	±360°	1200°/s	—		
	Medium gripper GM (Note 1)	—	14mm (Both fingers)	±0.01mm	—	94mm/s (One finger)	

(Note 1) Refer to the gripper selection guide in our ROBO Cylinder General Catalog.

(Note 2) This is the maximum payload on the gripper when it is attached to a SCARA Robot.

## Robot Specifications

	3-axis specification	4-axis specification	3-axis specification with medium gripper (GM)
Encoder type	Battery-less absolute encoder *		
User wiring	AWG26×8		
User piping	O.D. ø4, I.D. ø2.5, 2 air tubes Maximum working pressure 0.8MPa		
Standard cycle time *4 (sec)	0.79		0.79 (at no load on gripper)
Allowable torque (Axis 4) (N·m)	—	0.28	—
Allowable moment (N·m)	0.7		Ma, Mb, Mc : 0.7
Allowable inertial moment from the tip of the vertical axis *5 (kg·m <sup>2</sup> )	Rated 0.001 Maximum 0.01	Rated 0.001 Maximum 0.003	Maximum 0.001
Ambient operating temperature/humidity	Temperature 0 ~ 40°C, Humidity 20 ~ 85%RH (Non-condensing)		
Unit weight (kg)	7.5	8	8

\*The gripper is incremental type

## Attached Gripper Types

IXP-3N2508GM	The medium gripper RCP4-GRSML is installed at the tip of the vertical axis.
--------------	---

## Price List

Specification	Model number	Standard price
3-axis specification	IXP-3N2508	—
3-axis specification with medium gripper	IXP-3N2508GM	—
4-axis specification	IXP-4N2508	—

## Cable Length <Per Axis\*>

Type	Cable code	Standard price
Standard type	P (1m)	—
	S (3m)	—
	M (5m)	—
Specified length	X06 (6m) ~ X10 (10m)	—
	X11 (11m) ~ X15 (15m)	—
	X16 (16m) ~ X20 (20m)	—
Robot cable	R01 (1m) ~ R03 (3m)	—
	R04 (4m) ~ R05 (5m)	—
	R06 (6m) ~ R10 (10m)	—
	R11 (11m) ~ R15 (15m)	—
	R16 (16m) ~ R20 (20m)	—

\*The 3-axis specification requires three cables, while the gripper specification and 4-axis specification require four cables.



Dimensions



CAD drawings can be downloaded from the website. [www.intelligentactuator.com](http://www.intelligentactuator.com)

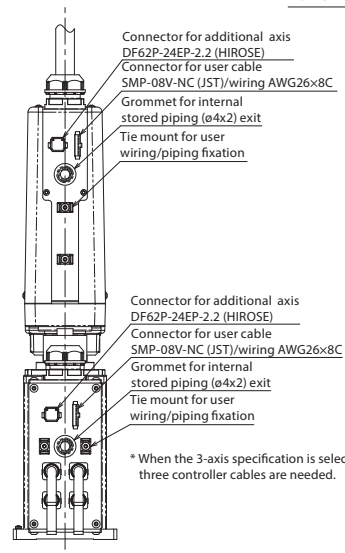
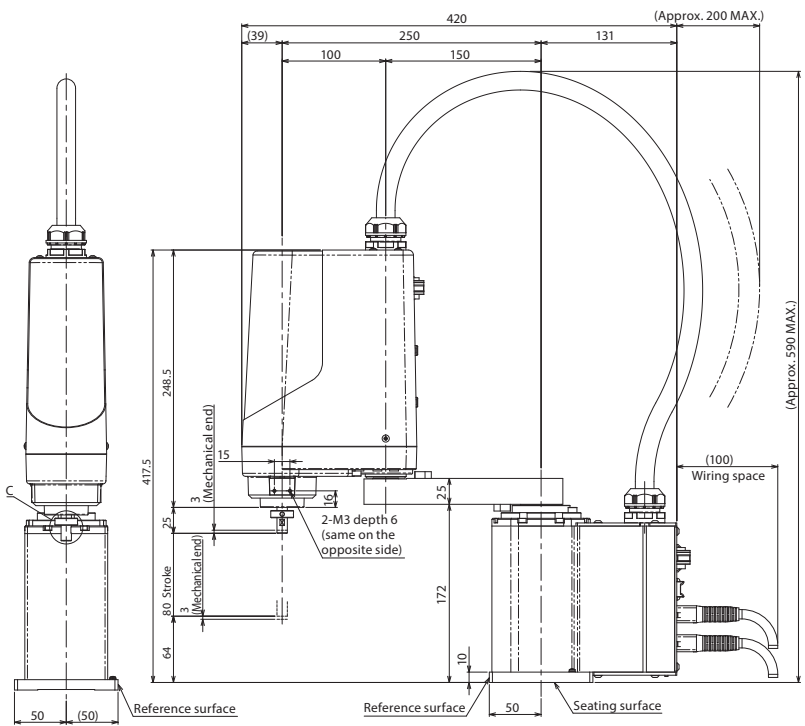
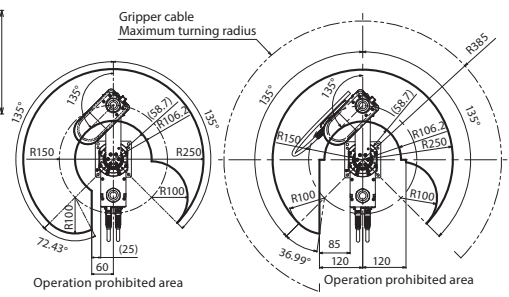
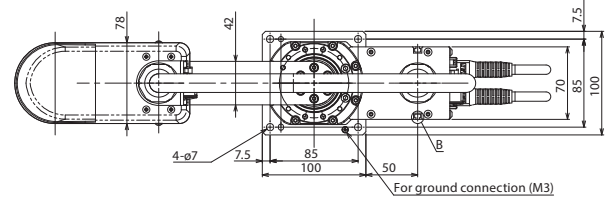
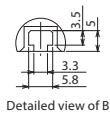

Connector for additional axis DF62P-24EP-2.2 (HIROSE)

Connector for user cable SMP-08V-NC (JST)/wiring AWG26x8C

Grommet for internal stored piping (ø4x2) exit

Tie mount for user wiring/piping fixation

\* When the 3-axis specification is selected, three controller cables are needed.

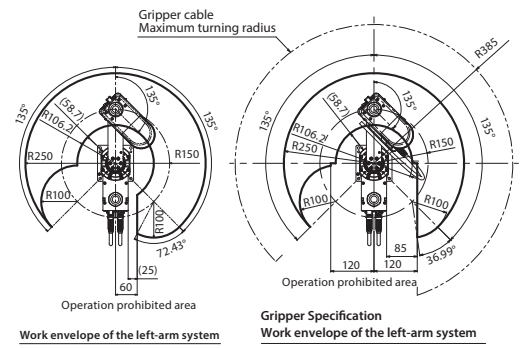
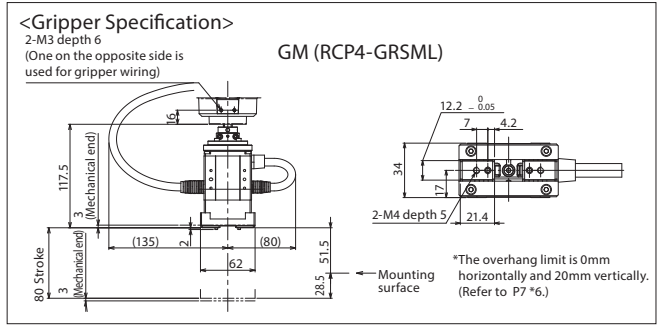
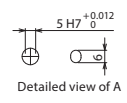
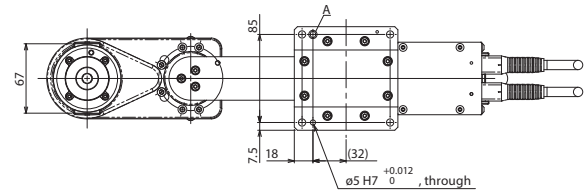
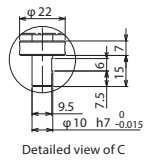

Applicable Controller

IXP series robots can operate with the following controllers. Make sure to select the model depending on the purpose.

Name	External view	Maximum number of controlled axes	Supply voltage	Control method				Max. pos. points	Standard price	Reference page
				Position	Pulse train	Program	Network *Option			
MSEL-PCX/PGX		4	Single-phase 100V ~ 230V	-	-	•	DevisNet CC-Link EtherNet/IP EtherCAT	30000	-	→P37

# IXP-3N3515 / 4N3515 3N3510

Arm length  
350mm

Vertical axis  
100mm

Vertical axis  
150mm

Model Specification Items	IXP	—	<input type="checkbox"/> N	35	<input type="checkbox"/>	—	WA	—	<input type="checkbox"/>	—	P3
	Series	Number of axes 3: 3 axes 4: 4 axes	Arm length 35: 350mm	Vertical axis stroke 15 :150mm 15GM :150mm 10GL :100mm	Gripper No gripper Medium gripper installed Large gripper installed	Encoder type WA: Battery-less absolute specification	Cable length N: None P: 1m S: 3m M: 5m	Applicable controller P3: MSEL			

\*Controller is not included.  
\*Refer to "Attached Gripper Types" for the types of grippers installed.



**POINT**  
Note on selection

- Refer to P. 7 for \*1 through \*6.
- The vertical axis has no brake.  
The unique structure holds the load in place even when the servo is turned off.
- The vertical axis does not support push-motion control.
- The allowable push force is 60N under condition of having a buffer such as a spring on a tool or the pressing side.
- Refer to P. 7 for the work envelope, and P. 8 for the notes on acceleration/deceleration setting.

\*The photograph shows a 4-axis specification.

Axis configuration		Arm length (mm)	Work envelope	Positioning repeatability *1	Maximum operating speed in PTP mode *2			Payload (kg) *3	
					No gripper	With medium gripper (GM)	With large gripper (GL)	Rated	Maximum
Axis 1	Arm 1	160	±127°	±0.03mm	2726mm/s (Composite speed)	2726mm/s (Composite speed)	1908mm/s (Composite speed)	1	3
Axis 2	Arm 2	190	±127°						
Axis 3	Vertical axis	—	150mm (Note 1)	±0.02mm	270mm/s	270mm/s	189mm/s		
Axis 4	Rotational axis	—	±360°	±0.02°	1000°/s	—	—	—	0.5 (Note 3)
	Medium gripper GM (Note 2)	—	14mm (Both fingers)	±0.01mm	—	94mm/s (One finger)	—		
	Large gripper GL (Note 2)	—	22mm (Both fingers)	±0.01mm	—	—	125mm/s (One finger)		

(Note 1) When the large gripper is installed, the work envelope of the vertical axis becomes 100mm. (Note 2) Refer to the gripper selection guide in our ROBO Cylinder General Catalog. (Note 3) This is the maximum payload on the gripper when it is attached to a SCARA Robot.

Robot Specifications		3-axis specification	4-axis specification	3-axis specification	
		No gripper		With medium gripper (GM)	With large gripper (GL)
Encoder type		Battery-less absolute encoder *			
User wiring		AWG24x6, AWG26x5P (shielded) *User cables are sold separately. Refer to the operation manual for detail.		User wiring is not supported because the gripper wiring is used.	
User piping		O.D. ø4, I.D. ø2.5, 3 air tubes (Maximum working pressure 0.8MPa)			
Standard cycle time *4 (sec)	SCARA	0.69		0.69	1.08
	Gripper (full stroke)	—		0.51	0.56
Allowable torque (Axis 4) (N·m)		—	1.4	—	
Allowable moment (N·m)		2.9		Ma: 1.9 Mb: 2.7 Mc: 2.9	Ma: 2.9 Mb: 2.9 Mc: 2.9
Allowable inertial moment from the tip of the vertical axis *5 (kg·m <sup>2</sup> )		Rated 0.003 Maximum 0.01	Rated 0.003 Maximum 0.003	Maximum 0.002	Maximum 0.009
Ambient operating temperature/humidity		Temperature 0 ~ 40°C Humidity 20 ~ 85%RH (Non-condensing)			
Unit weight (kg)		12	13	12.5	13

\*The gripper is incremental type

Attached Gripper Types	
IXP-3N3515GM	The medium gripper RCP4-GRSML is installed at the tip of the vertical axis.
IXP-3N3510GL	The large gripper RCP4-GRSLL is installed at the tip of the vertical axis.

Price List		
Gripper	SCARA 3-axis specification	Standard price
None	IXP-3N3515	—
Medium gripper	IXP-3N3515GM	—
Large gripper	IXP-3N3510GL	—
Gripper	SCARA 4-axis specification	Standard price
None	IXP-4N3515	—

Cable Length <Per Axis*>		
Type	Cable code	Standard price
Standard type	P (1m)	—
	S (3m)	—
	M (5m)	—
Specified length	X06 (6m) ~ X10 (10m)	—
	X11 (11m) ~ X15 (15m)	—
	X16 (16m) ~ X20 (20m)	—
Robot cable	R01 (1m) ~ R03 (3m)	—
	R04 (4m) ~ R05 (5m)	—
	R06 (6m) ~ R10 (10m)	—
	R11 (11m) ~ R15 (15m)	—
	R16 (16m) ~ R20 (20m)	—

\*The 3-axis specification requires three cables, while the gripper specification and 4-axis specification require four cables.

Dimensions



CAD drawings can be downloaded from the website.

www.intelligentactuator.com

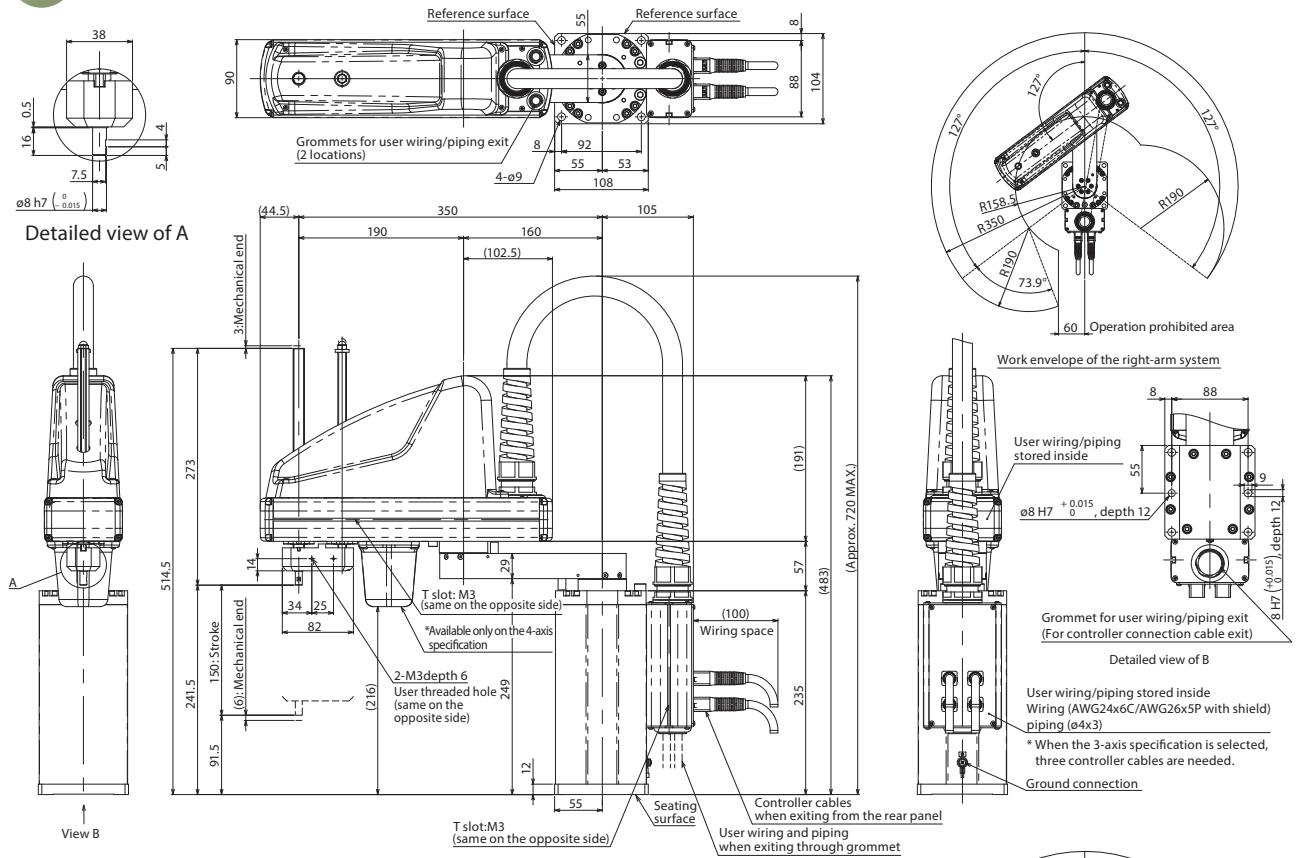

<Gripper Specification>

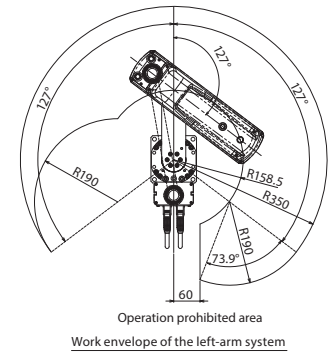
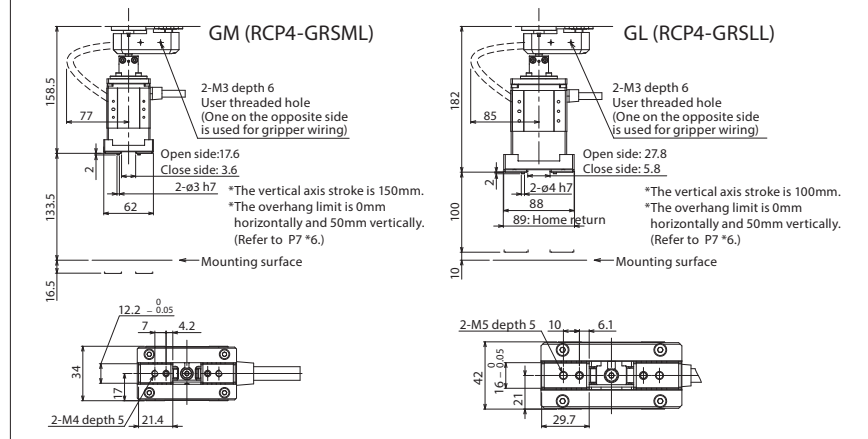

Applicable Controller

IXP series robots can operate with the following controllers. Make sure to select the model depending on the purpose.

Name	External view	Maximum number of controlled axes	Supply voltage	Control method				Max. pos. points	Standard price	Reference page
				Position	Pulse train	Program	Network *Option			
MSEL-PCX/PGX		4	Single-phase 100V ~ 230V	-	-	•	DeviceNet CC-Link PROFIBUS EtherNet/IP PROFINET EtherCAT	30000	-	→P37

# IXP-3N4515 / 4N4515 3N4510

Arm length  
450mm

Vertical axis  
100mm

Vertical axis  
150mm

■ Model Specification Items	IXP	—	<input type="checkbox"/> N	45	<input type="checkbox"/>	—	WA	—	<input type="checkbox"/>	—	P3
	Series	Number of axes 3: 3 axes 4: 4 axes	Arm length 45: 450mm	Vertical axis stroke 15 :150mm 15GM :150mm 10GL :100mm	Gripper No gripper Medium gripper installed Large gripper installed	Encoder type WA: Battery-less absolute specification	Cable length N: None P: 1m S: 3m M: 5m	Applicable controller P3: MSEL			

\*Controller is not included.  
\*Refer to "Attached Gripper Types" for the types of grippers installed.



**POINT**  
Note on selection

- Refer to P. 7 for \*1 through \*5.
- The vertical axis has no brake.  
The unique structure holds the load in place even when the servo is turned off.
- The vertical axis does not support push-motion control.
- The allowable push force is 60N under condition of having a buffer such as a spring on a tool or the pressing side.
- Refer to P. 7 for the work envelope, and P. 8 for the notes on acceleration/deceleration setting.

\*The photograph shows a 4-axis specification.

Axis configuration		Arm length (mm)	Work envelope	Positioning repeatability *1	Maximum operating speed in PTP mode *2			Payload (kg) *3	
					No gripper	With medium gripper (GM)	With large gripper (GL)	Rated	Maximum
Axis 1	Arm 1	260	±127°	±0.03mm	2438mm/s (Composite speed)	2438mm/s (Composite speed)	2060mm/s (Composite speed)	1	3
Axis 2	Arm 2	190	±127°						
Axis 3	Vertical axis	—	150mm (Note 1)	±0.02mm	270mm/s	270mm/s	189mm/s		
Axis 4	Rotational axis	—	±360°	±0.02°	1000°/s	—	—	—	0.5 (Note 3)
	Medium gripper GM (Note 2)	—	14mm (Both fingers)	±0.01mm	—	94mm/s (One finger)	—		
	Large gripper GL (Note 2)	—	22mm (Both fingers)	±0.01mm	—	—	125mm/s (One finger)		

(Note 1) When the large gripper is installed, the work envelope of the vertical axis becomes 100mm. (Note 2) Refer to the gripper selection guide in our ROBO Cylinder General Catalog. (Note 3) This is the maximum payload on the gripper when it is attached to a SCARA Robot.

Robot Specifications		3-axis specification	4-axis specification	3-axis specification	
		No gripper		With medium gripper (GM)	With large gripper (GL)
Encoder type		Battery-less absolute encoder *			
User wiring		AWG24x6, AWG26x5P (shielded) *User cables are sold separately. Refer to the operation manual for detail.		User wiring is not supported because the gripper wiring is used.	
User piping		O.D. ø4, I.D. ø2.5, 3 air tubes (Maximum working pressure 0.8MPa)			
Standard cycle time *4 (sec)	SCARA	0.67		0.67	0.95
	Gripper (full stroke)	—		0.51	0.56
Allowable torque (Axis 4) (N·m)		—	1.4	—	
Allowable moment (N·m)		2.9		Ma: 1.9 Mb: 2.7 Mc: 2.9	Ma: 2.9 Mb: 2.9 Mc: 2.9
Allowable inertial moment from the tip of the vertical axis *5 (kg·m <sup>2</sup> )		Rated 0.003 Maximum 0.01	Rated 0.003 Maximum 0.003	Maximum 0.002	Maximum 0.009
Ambient operating temperature/humidity		Temperature 0 ~ 40°C Humidity 20 ~ 85%RH (Non-condensing)			
Unit weight (kg)		13	14	13.5	14

\*The gripper is incremental type

Attached Gripper Types	
IXP-3N4515GM	The medium gripper RCP4-GRSML is installed at the tip of the vertical axis.
IXP-3N4510GL	The large gripper RCP4-GRSLL is installed at the tip of the vertical axis.

Price List		
Gripper	SCARA 3-axis specification	Standard price
None	IXP-3N4515	—
Medium gripper	IXP-3N4515GM	—
Large gripper	IXP-3N4510GL	—
Gripper	SCARA 4-axis specification	Standard price
None	IXP-4N4515	—

Cable Length <Per Axis*>		
Type	Cable code	Standard price
Standard type	P (1m)	—
	S (3m)	—
	M (5m)	—
Specified length	X06 (6m) ~ X10 (10m)	—
	X11 (11m) ~ X15 (15m)	—
	X16 (16m) ~ X20 (20m)	—
Robot cable	R01 (1m) ~ R03 (3m)	—
	R04 (4m) ~ R05 (5m)	—
	R06 (6m) ~ R10 (10m)	—
	R11 (11m) ~ R15 (15m)	—
	R16 (16m) ~ R20 (20m)	—

\*The 3-axis specification requires three cables, while the gripper specification and 4-axis specification require four cables.



Dimensions



CAD drawings can be downloaded from the website.

www.intelligentactuator.com

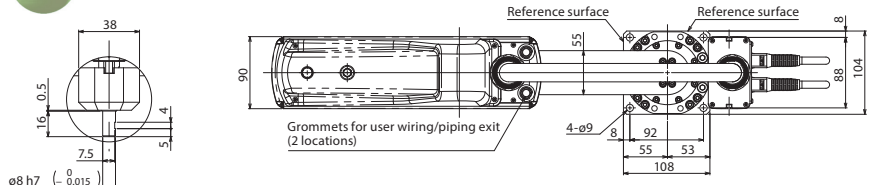

Detailed view of A

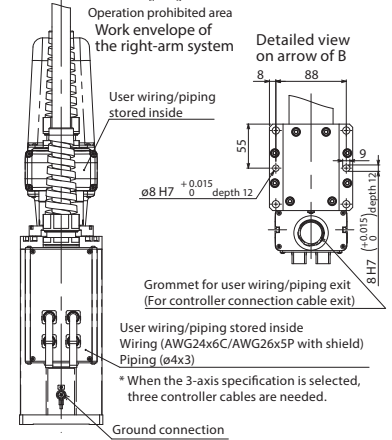
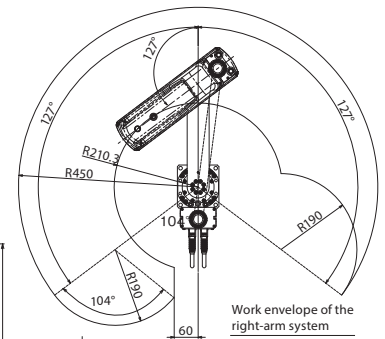
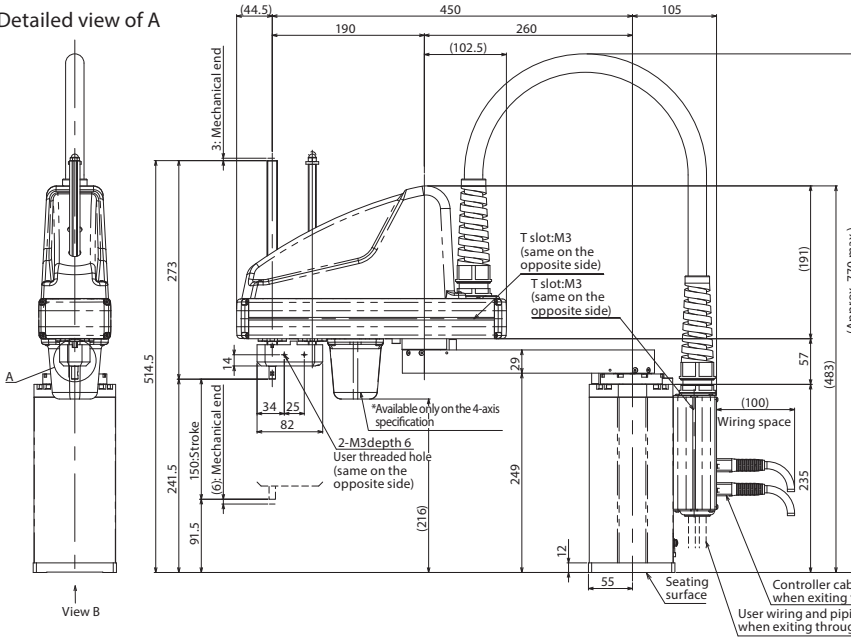

<Gripper Specification>

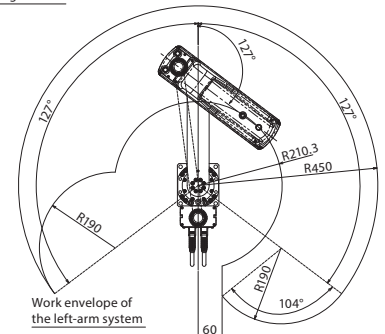
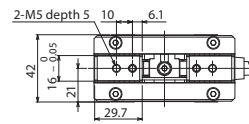
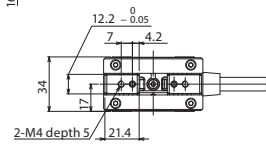
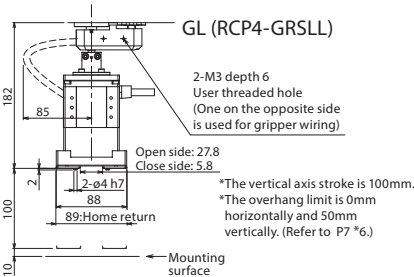
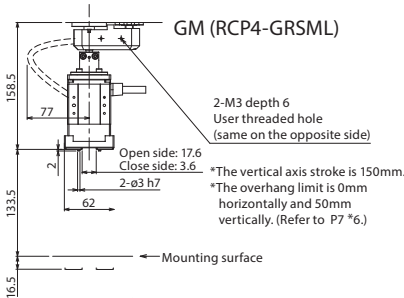

Applicable Controller

IXP series robots can operate with the following controllers. Make sure to select the model depending on the purpose.

Name	External view	Maximum number of controlled axes	Supply voltage	Control method				Max. pos. points	Standard price	Reference page
				Position	Pulse train	Program	Network *Option			
MSEL-PCX/PGX		4	Single-phase 100V ~ 230V	-	-	•	DeviceNet CC-Link EtherNet/IP EtherCAT	30000	-	→P37

# IXP-3N5520/4N5520 3N5515

Arm length <b>550mm</b>	Vertical axis <b>200mm</b>	Vertical axis <b>150mm</b>
----------------------------	-------------------------------	-------------------------------

Model Specification Items	Series	IXP	Number of axes	N	55	Arm length	20	200mm	Gripper	No gripper	Encoder type	WA	Battery-less absolute specification	Cable length	N: None P: 1m S: 3m M: 5m	Applicable controller	P3: MSEL	Option	B: Brake
		3: 3 axes 4: 4 axes	55: 550mm	20 :200mm 15GL :150mm 15GW :150mm	No gripper Large gripper installed Extra-large gripper installed									X□□: Specified length R□□: Robot cable Cable length described below					

\*Controller is not included.  
\*Refer to "Attached Gripper Types" for the types of grippers installed.



**POINT**  
Note on selection

- Refer to P. 7 for \*1 through \*6.
- Make sure to select the brake option when the payload is 4kg or more.
- The vertical axis does not support push-motion control.
- The allowable push force should be 90N under condition of having a buffer such as a spring on a tool or the pressing side.
- Refer to P. 7 for the work envelope, and P. 8 for the notes on acceleration/deceleration setting.

\*The photograph shows a 4-axis specification.

## Robot Specifications

Axis configuration	Arm length (mm)	Work envelope	Positioning repeatability *1	Maximum operating speed in PTP mode *2			Payload (kg) *3		
				No gripper	With large gripper (GL)	With extra-large gripper (GW)	Rated	Maximum	
Axis 1	Arm 1	260	±127°	±0.04mm	2943mm/s (Composite speed)	2943mm/s (Composite speed)	2943mm/s (Composite speed)	2	6
Axis 2	Arm 2	290	±127°						
Axis 3	Vertical axis	—	200mm (Note 1)	±0.02mm	240mm/s	240mm/s	240mm/s		
Axis 4	Rotational axis	—	±360°	±0.02°	700°/s	—	—	—	1.5 (Note 3)
	Large gripper GL (Note 2)	—	22mm (Both fingers)	±0.01mm	—	125mm/s (One finger)	—		
	Extra-large gripper GW (Note 2)	—	30mm (Both fingers)	±0.01mm	—	—	157mm/s (One finger)	—	2.5 (Note 3)

(Note 1) When the extra-large gripper is installed, the work envelope of the vertical axis becomes 150mm. (Note 2) Refer to the gripper selection guide in our ROBO Cylinder General Catalog. (Note 3) This is the maximum payload on the gripper when it is attached to a SCARA Robot.

## Robot Specifications

	3-axis specification	4-axis specification	3-axis specification	
	No gripper		With large gripper (GL)	With extra-large gripper (GW)
Encoder type	Battery-less absolute encoder *			
User wiring	AWG24×6, AWG26×5P (shielded) *User cables are sold separately. Refer to the operation manual for detail.		User wiring is not supported because the gripper wiring is used.	
User piping	O.D. ø4, I.D. ø2.5, 3 air tubes Maximum working pressure 0.8MPa			
Standard cycle time *4 (sec)	0.73		0.73 (When transporting 2kg including a gripper)	
Allowable torque (Axis 4) (N·m)	—	3.06	—	
Allowable moment (N·m)	9.4		Ma: 3.8 Mb: 5.5 Mc: 9.4	Ma: 9.4 Mb: 9.4 Mc: 9.4
Allowable inertial moment from the tip of the vertical axis *5 (kg·m <sup>2</sup> )	Rated 0.01 Maximum 0.03	Rated 0.01 Maximum 0.01	Maximum 0.026	Maximum 0.024
Ambient operating temperature/humidity	Temperature 0 ~ 40°C Humidity 20 ~ 85%RH (Non-condensing)			
Unit weight (kg)	20	21	21.3	21.9

\*The gripper is incremental type

## Attached Gripper Types

IXP-3N5515GL	The large gripper RCP4-GRSLL is installed at the tip of the vertical axis.
IXP-3N5515GW	The extra-large gripper RCP4-GRSWL is installed at the tip of the vertical axis.

## Option

Name	Option code	Reference page	Standard price
Brake	B	Refer to our ROBO Cylinder General Catalog	—

\*Make sure to select the brake option when the payload is 4kg or more.

## Price List

Specification	Model number	Standard price
3-axis specification	IXP-3N5520	—
3-axis specification with large gripper	IXP-3N5515GL	—
3-axis specification with extra-large gripper	IXP-3N5515GW	—
4-axis specification	IXP-4N5520	—

## Cable Length <Per Axis\*>

Type	Cable code	Standard price
Standard type	P (1m)	—
	S (3m)	—
	M (5m)	—
Specified length	X06 (6m) ~ X10 (10m)	—
	X11 (11m) ~ X15 (15m)	—
	X16 (16m) ~ X20 (20m)	—
Robot cable	R01 (1m) ~ R03 (3m)	—
	R04 (4m) ~ R05 (5m)	—
	R06 (6m) ~ R10 (10m)	—
	R11 (11m) ~ R15 (15m)	—
	R16 (16m) ~ R20 (20m)	—

\*The 3-axis specification requires three cables, while the gripper specification and 4-axis specification require four cables.

Dimensions



CAD drawings can be downloaded from the website.

[www.intelligentactuator.com](http://www.intelligentactuator.com)

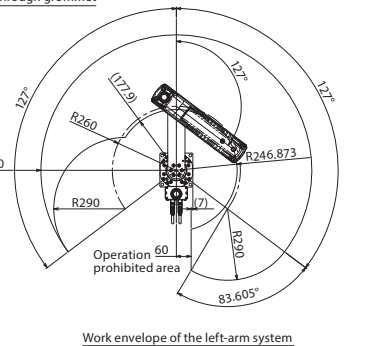
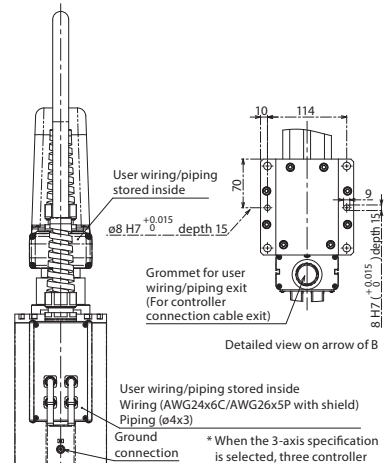
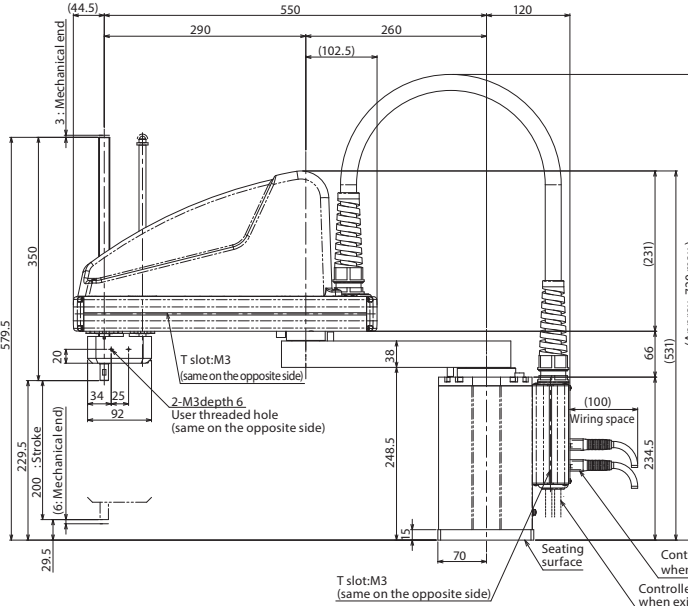
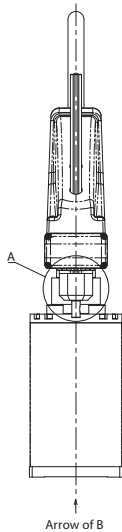
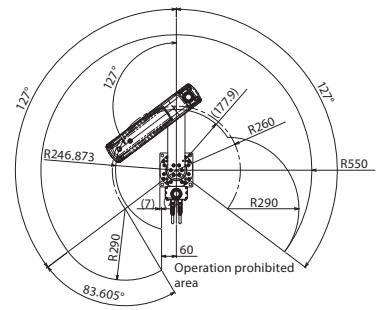
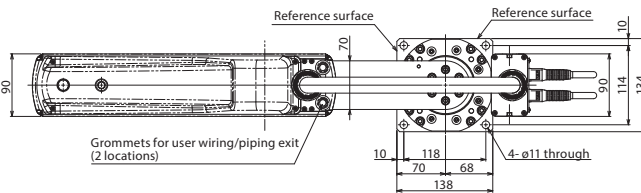
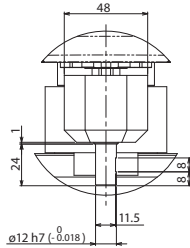

<Gripper Specification>

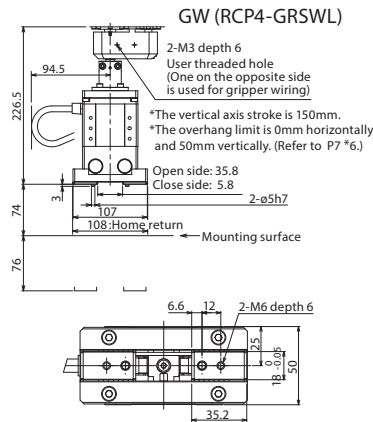
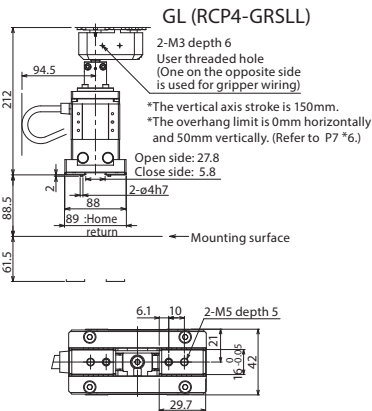

Applicable Controller

IXP series robots can operate with the following controllers. Make sure to select the model depending on the purpose.

Name	External view	Maximum number of controlled axes	Supply voltage	Control method				Max. pos. points	Standard price	Reference page
				Position	Pulse train	Program	Network *Option			
MSEL-PCX/PGX		4	Single-phase 100V ~ 230V	-	-	•	DeviceNet CC-Link EtherNet/IP PROFINET EtherCAT	30000	-	→P37

# IXP-3N6520/4N6520 3N6515

Arm length <b>650mm</b>	Vertical axis <b>200mm</b>	Vertical axis <b>150mm</b>
----------------------------	-------------------------------	-------------------------------

Model Specification Items	Series	IXP	Number of axes	N 65	Arm length	65: 650mm 20 :200mm 15GL :150mm 15GW :150mm	Vertical axis stroke	No gripper Large gripper installed Extra-large gripper installed	Gripper	Encoder type	WA: Battery-less absolute specification	Cable length	N: None P: 1m S: 3m M: 5m	X□□: Specified length R□□: Robot cable Cable length described below	Applicable controller	P3: MSEL	Option	Option below See price list
	3: 3 axes 4: 4 axes																	

\*Controller is not included.  
\*Refer to "Attached Gripper Types" for the types of grippers installed.



**POINT**  
Note on selection

- Refer to P. 7 for \*1 through \*6.
- Make sure to select the brake option when the payload is 4kg or more.
- The vertical axis does not support push-motion control.
- The allowable push force should be 90N under condition of having a buffer such as a spring on a tool or the pressing side.
- Refer to P. 7 for the work envelope, and P. 8 for the notes on acceleration/deceleration setting.

\*The photograph shows a 4-axis specification.

Robot Specifications									
Axis configuration	Arm length (mm)	Work envelope	Positioning repeatability *1	Maximum operating speed in PT mode *2			Payload (kg) *3		
				No gripper	With large gripper (GL)	With extra-large gripper (GW)	Rated	Maximum	
Axis 1	Arm 1	360	±127°	±0.04mm	2916mm/s (Composite speed)	2916mm/s (Composite speed)	2916mm/s (Composite speed)	2	6
Axis 2	Arm 2	290	±127°						
Axis 3	Vertical axis	—	200mm (Note 1)	±0.02mm	240mm/s	240mm/s	240mm/s		
Axis 4	Rotational axis	—	±360°	±0.02°	700°/s	—	—	—	1.5 (Note 3)
	Large gripper GL (Note 2)	—	22mm (Both fingers)	±0.01mm	—	125mm/s (One finger)	—		
	Extra-large gripper GW (Note 2)	—	30mm (Both fingers)	±0.01mm	—	—	157mm/s (One finger)		

(Note 1) When the extra-large gripper is installed, the work envelope of the vertical axis becomes 150mm. (Note 2) Refer to the gripper selection guide in our ROBO Cylinder General Catalog. (Note 3) This is the maximum payload on the gripper when it is attached to a SCARA Robot.

Robot Specifications	3-axis specification		4-axis specification	
	No gripper	4-axis specification	3-axis specification	3-axis specification
Encoder type	Battery-less absolute encoder *			
User wiring	AWG24×6, AWG26×5P (shielded) *User cables are sold separately. Refer to the operation manual for detail.		User wiring is not supported because the gripper wiring is used.	
User piping	O.D. ø4, I.D. ø2.5, 3 air tubes Maximum working pressure 0.8MPa			
Standard cycle time *4 (sec)	0.81		0.81 (When transporting 2kg including a gripper)	
Allowable torque (Axis 4) (N·m)	—	3.06	—	
Allowable moment (N·m)	9.4		Ma: 3.8 Mb: 5.5 Mc: 9.4	Ma: 9.4 Mb: 9.4 Mc: 9.4
Allowable inertial moment from the tip of the vertical axis *5 (kg·m <sup>2</sup> )	Rated 0.01 Maximum 0.03	Rated 0.01 Maximum 0.01	Maximum 0.026	Maximum 0.024
Ambient operating temperature/humidity	Temperature 0 ~ 40°C Humidity 20 ~ 85%RH (Non-condensing)			
Unit weight (kg)	21	22	22.3	22.9

\*The gripper is incremental type

Attached Gripper Types	
IXP-3N6515GL	The large gripper RCP4-GRSLL is installed at the tip of the vertical axis.
IXP-3N6515GW	The extra-large gripper RCP4-GRSWL is installed at the tip of the vertical axis.

Option			
Name	Option code	Reference page	Standard price
Brake	B	Refer to our ROBO Cylinder General Catalog	—

Price List		
Specification	Model number	Standard price
3-axis specification	IXP-3N6520	—
3-axis specification with large gripper	IXP-3N6515GL	—
3-axis specification with extra-large gripper	IXP-3N6515GW	—
4-axis specification	IXP-4N6520	—

Cable Length <Per Axis*>		
Type	Cable code	Standard price
Standard type	P (1m)	—
	S (3m)	—
	M (5m)	—
Specified length	X06 (6m) ~ X10 (10m)	—
	X11 (11m) ~ X15 (15m)	—
	X16 (16m) ~ X20 (20m)	—
Robot cable	R01 (1m) ~ R03 (3m)	—
	R04 (4m) ~ R05 (5m)	—
	R06 (6m) ~ R10 (10m)	—
	R11 (11m) ~ R15 (15m)	—
	R16 (16m) ~ R20 (20m)	—

\*The 3-axis specification requires three cables, while the gripper specification and 4-axis specification require four cables.

\*Make sure to select this when the transported object is 4kg or more.



**Dimensions**



CAD drawings can be downloaded from the website.

[www.intelligentactuator.com](http://www.intelligentactuator.com)

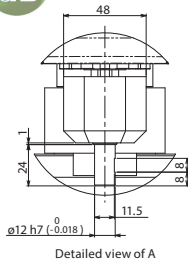

Detailed view of A

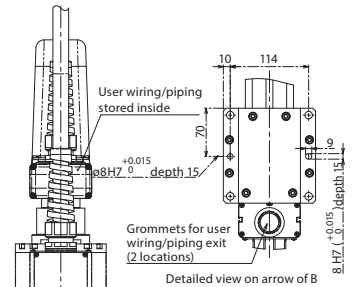
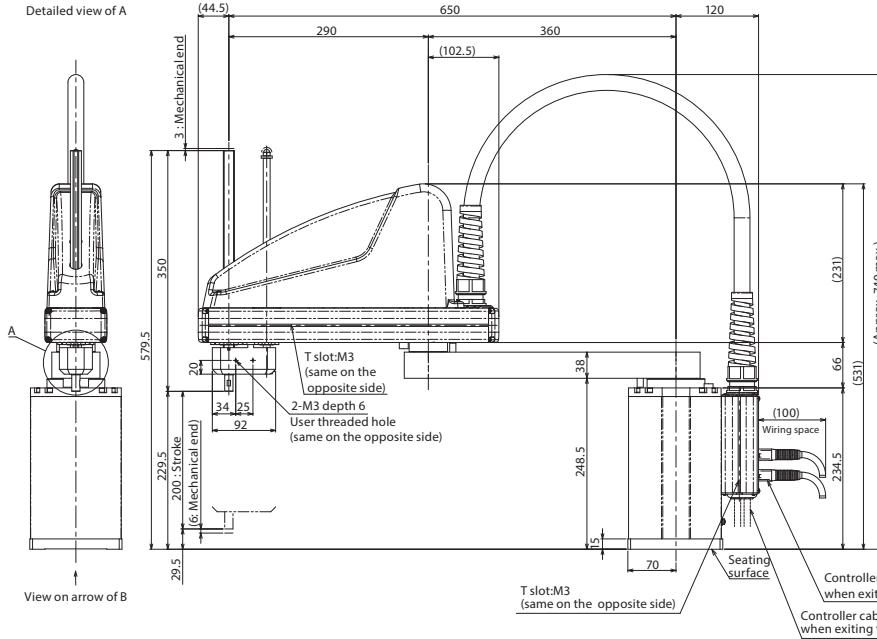
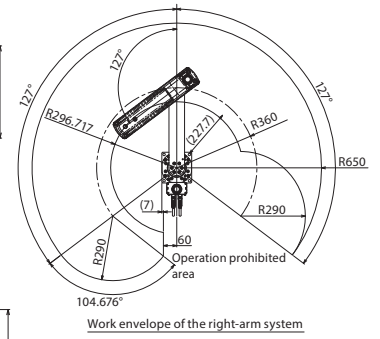
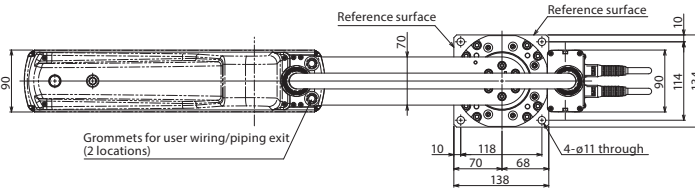

User wiring/piping stored inside  
Wiring (AWG24x6C/AWG26x5P with shield)  
Piping (ø4x3)  
Ground \*When the 3-axis specification connection is selected, three controller cables are needed.

**<Gripper Specification>**

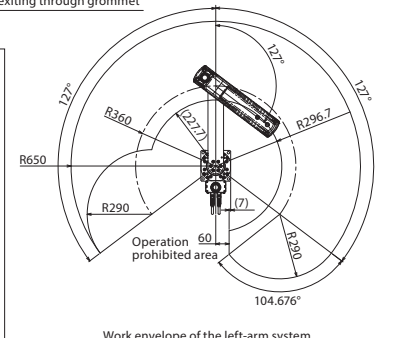
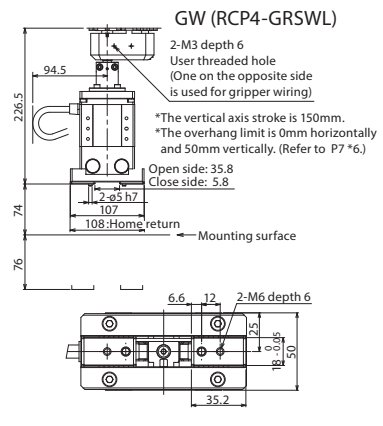
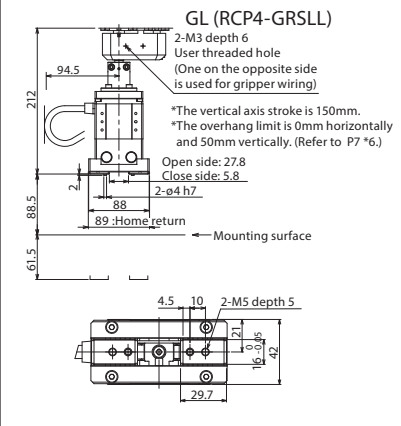

**Applicable Controller**

IXP series robots can operate with the following controllers. Make sure to select the model depending on the purpose.

Name	External view	Maximum number of controlled axes	Supply voltage	Control method				Max. pos. points	Standard price	Reference page
				Position	Pulse train	Program	Network *Option			
MSEL-PCX/PGX		4	Single-phase 100V ~ 230V	-	-	•	DeviceNet CC-Link EtherNet/IP EtherCAT	30000	-	→P37

# IXP- 3C3515/4C3515

Clean room specification

Arm length 350mm

Vertical axis 150mm

■ Model Specification Items	IXP	<input type="checkbox"/>	C	35	15	—	WA	<input type="checkbox"/>	—	P3	<input type="checkbox"/>
	Series	Number of axes 3: 3 axes 4: 4 axes	Type C: Cleanroom specification	Arm length 35: 350mm	Vertical axis stroke 15: 150mm	Encoder type WA: Battery-less absolute specification	Cable length N: None P: 1m S: 3m M: 5m	X□□: Specified length R□□: Robot cable Cable length described below Refer to the price list.	Applicable controller P3: MSEL	Option Option below Refer to the price list	

\*Controller is not included. \* Please select VLL or VLR for suction of the L-shaped joint.



\*The photograph shows a 4-axis specification.

**POINT**  
Note on selection

- Refer to P. 7 for \*1 through \*7.
- The vertical axis has no brake. The unique structure holds the load in place even when the servo is turned off.
- The vertical axis does not support push-motion control.
- The allowable push force is 60N under condition of having a buffer such as a spring on a tool or the pressing side.
- Refer to P. 7 for the work envelope, and P. 8 for the notes on acceleration/deceleration setting.

Robot Specifications							
Axis configuration		Arm length (mm)	Work envelope	Positioning repeatability *1	Maximum operating speed in PTP mode *2	Payload (kg) *3	
						Rated	Maximum
Axis 1	Arm 1	160	±127°	±0.03mm	2399mm/s (Composite speed)	1	3
Axis 2	Arm 2	190	±127°				
Axis 3	Vertical axis	—	150mm	±0.02mm	270mm/s		
Axis 4	Rotational axis	—	±360°	±0.02°	1000°/s		

Robot Specifications		
	3-axis specification	4-axis specification
Encoder type	Battery-less absolute encoder	
User piping joint	One touch piping joint 1 Applicable tube O.D. ø6	
Standard cycle time *4 (sec)	0.76	
Allowable torque (Axis 4) (N-m)	—	1.4
Allowable moment (N-m)	2.9	
Allowable inertial moment from the tip of the vertical axis *5 (kg-m <sup>2</sup> )	Rated 0.003 Maximum 0.01	Rated 0.003 Maximum 0.003
Ambient operating temperature/humidity	Temperature 0 ~ 40°C Humidity 20 ~ 85%RH (Non-condensing)	
Unit weight (kg)	13	14
Piping joint for suction	One touch piping joint 3 Applicable tubes O.D. ø6	
Suction pressure	-3 ~ -5kPa	
Suction power *7	12NE/min	
cleanliness class	Class10 (Fed. Std. 209D)	
	Equivalent to Class 3.5 (ISO 14644-1)	

Option price (Standard price)			
Name	Option code	Reference page	Standard price
L-shaped joint left side exit	VLL	→P5	—
L-shaped joint right side exit	VLR	→P5	—

Price List (Standard price)		
Specification	Model number	Standard price
3-axis specification	IXP-3C3515	—
4-axis specification	IXP-4C3515	—

Cable Length (Standard price) <Per Axis*>		
Type	Cable code	Standard price
Standard type	P (1m)	—
	S (3m)	—
	M (5m)	—
Specified length	X06 (6m) ~ X10 (10m)	—
	X11 (11m) ~ X15 (15m)	—
	X16 (16m) ~ X20 (20m)	—
Robot cable	R01 (1m) ~ R03 (3m)	—
	R04 (4m) ~ R05 (5m)	—
	R06 (6m) ~ R10 (10m)	—
	R11 (11m) ~ R15 (15m)	—
	R16 (16m) ~ R20 (20m)	—

\* The 3-axis specification requires three cables, while the gripper specification and 4-axis specification require four cables.

Dimensions



CAD drawings can be downloaded from the website.

www.intelligentactuator.com

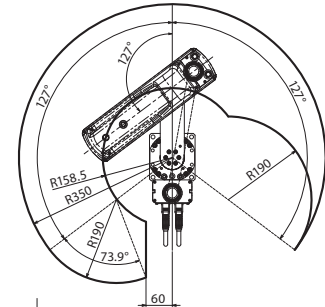
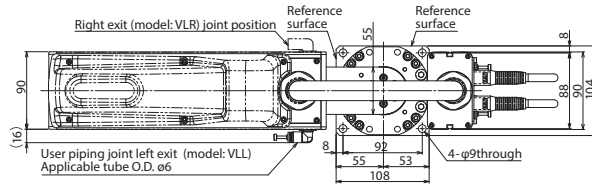
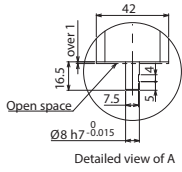

Operation prohibited area  
Work envelope of the right-arm system

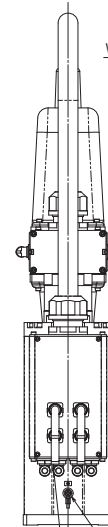
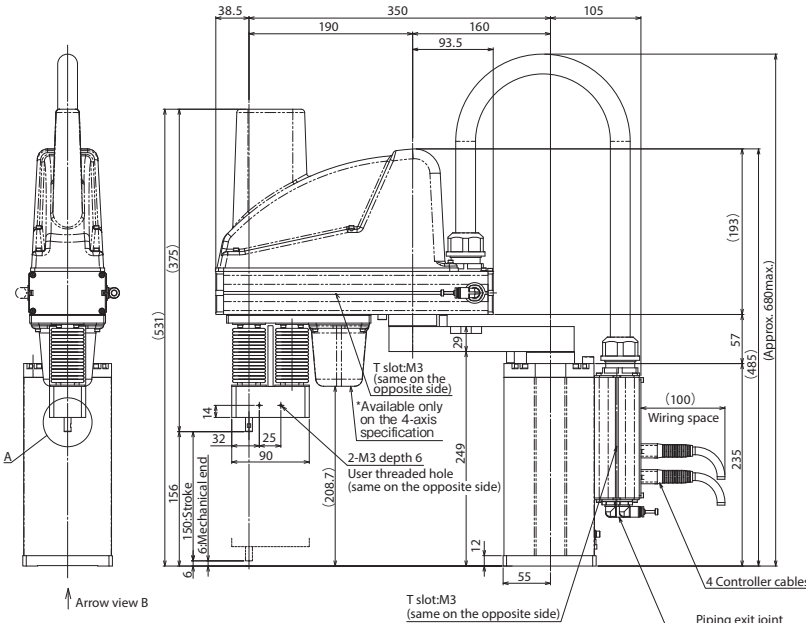

When the 3-axis specification is selected, three controller cables are needed.

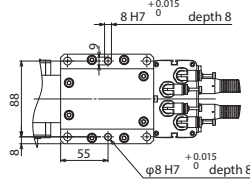



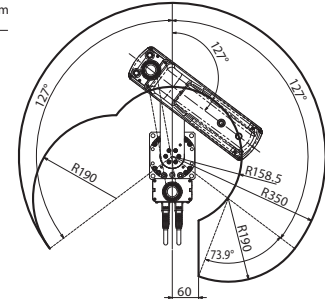

Detailed view on arrow of B



Operation prohibited area  
Work envelope of the left-arm system

Applicable Controller

IXP series robots can operate with the following controllers. Make sure to select the model depending on the purpose.

Name	External view	Maximum number of controlled axes	Supply voltage	Control method				Max. pos. points	Standard price	Reference page
				Position	Pulse train	Program	Network *Option			
MSEL-PCX/PGX		4	Single-phase 100V ~ 230V	-	-	•	DeviceNet  CC-Link  EtherNet/IP  PROFINET  EtherCAT	30000	-	→P37

# IXP- 3C4515/4C4515

Clean room specification

Arm length 450mm

Vertical axis 150mm

■ Model Specification Items	IXP	<input type="checkbox"/>	C	45	15	—	WA	<input type="checkbox"/>	—	P3	<input type="checkbox"/>
	Series	Number of axes 3: 3 axes 4: 4 axes	Type C: Cleanroom specification	Arm length 45: 450mm	Vertical axis stroke 15: 150mm	Encoder type WA: Battery-less absolute specification	Cable length N: None P: 1m S: 3m M: 5m	X <input type="checkbox"/> : Specified length R <input type="checkbox"/> : Robot cable Cable length described below Refer to the price list.	Applicable controller P3: MSEL	Option Option below Refer to the price list	

\*Controller is not included. \* Please select VLL or VLR for suction of the L-shaped joint.



\*The photograph shows a 4-axis specification.

**POINT**  
Note on selection

- Refer to P. 7 for \*1 through \*7.
- The vertical axis has no brake. The unique structure holds the load in place even when the servo is turned off.
- The vertical axis does not support push-motion control.
- The allowable push force is 60N under condition of having a buffer such as a spring on a tool or the pressing side.
- Refer to P. 7 for the work envelope, and P. 8 for the notes on acceleration/deceleration setting.

Robot Specifications							
Axis configuration		Arm length (mm)	Work envelope	Positioning repeatability *1	Maximum operating speed in PTP mode *2	Payload (kg) *3	
						Rated	Maximum
Axis 1	Arm 1	260	±127°	±0.03mm	2194mm/s (Composite speed)	1	3
Axis 2	Arm 2	190	±127°				
Axis 3	Vertical axis	—	150mm	±0.02mm	270mm/s		
Axis 4	Rotational axis	—	±360°	±0.02°	1000°/s		

Robot Specifications		
	3-axis specification	4-axis specification
Encoder type	Battery-less absolute encoder	
User piping joint	One touch piping joint 1 Applicable tube O.D. ø6	
Standard cycle time *4 (sec)	0.74	
Allowable torque (Axis 4) (N·m)	—	1.4
Allowable moment (N·m)	2.9	
Allowable inertial moment from the tip of the vertical axis *5 (kg·m <sup>2</sup> )	Rated 0.003 Maximum 0.01	Rated 0.003 Maximum 0.003
Ambient operating temperature/humidity	Temperature 0 ~ 40°C Humidity 20 ~ 85%RH (Non-condensing)	
Unit weight (kg)	14	15
Piping joint for suction	One touch piping joint 3 Applicable tubes O.D. ø6	
Suction pressure	-3 ~ -5kPa	
Suction power *7	12Nℓ/min	
cleanliness class	Class10 (Fed. Std. 209D)	
	Equivalent to Class 3.5 (ISO 14644-1)	

Price List (Standard price)		
Specification	Model number	Standard price
3-axis specification	IXP-3C4515	—
4-axis specification	IXP-4C4515	—

Cable Length (Standard price) <Per Axis*>		
Type	Cable code	Standard price
Standard type	P (1m)	—
	S (3m)	—
	M (5m)	—
Specified length	X06 (6m) ~ X10 (10m)	—
	X11 (11m) ~ X15 (15m)	—
	X16 (16m) ~ X20 (20m)	—
Robot cable	R01 (1m) ~ R03 (3m)	—
	R04 (4m) ~ R05 (5m)	—
	R06 (6m) ~ R10 (10m)	—
	R11 (11m) ~ R15 (15m)	—
	R16 (16m) ~ R20 (20m)	—

\* The 3-axis specification requires three cables, while the gripper specification and 4-axis specification require four cables.

Option price (Standard price)			
Name	Option code	Reference page	Standard price
L-shaped joint left side exit	VLL	→P5	—
L-shaped joint right side exit	VLR	→P5	—

Dimensions



CAD drawings can be downloaded from the website.

www.intelligentactuator.com

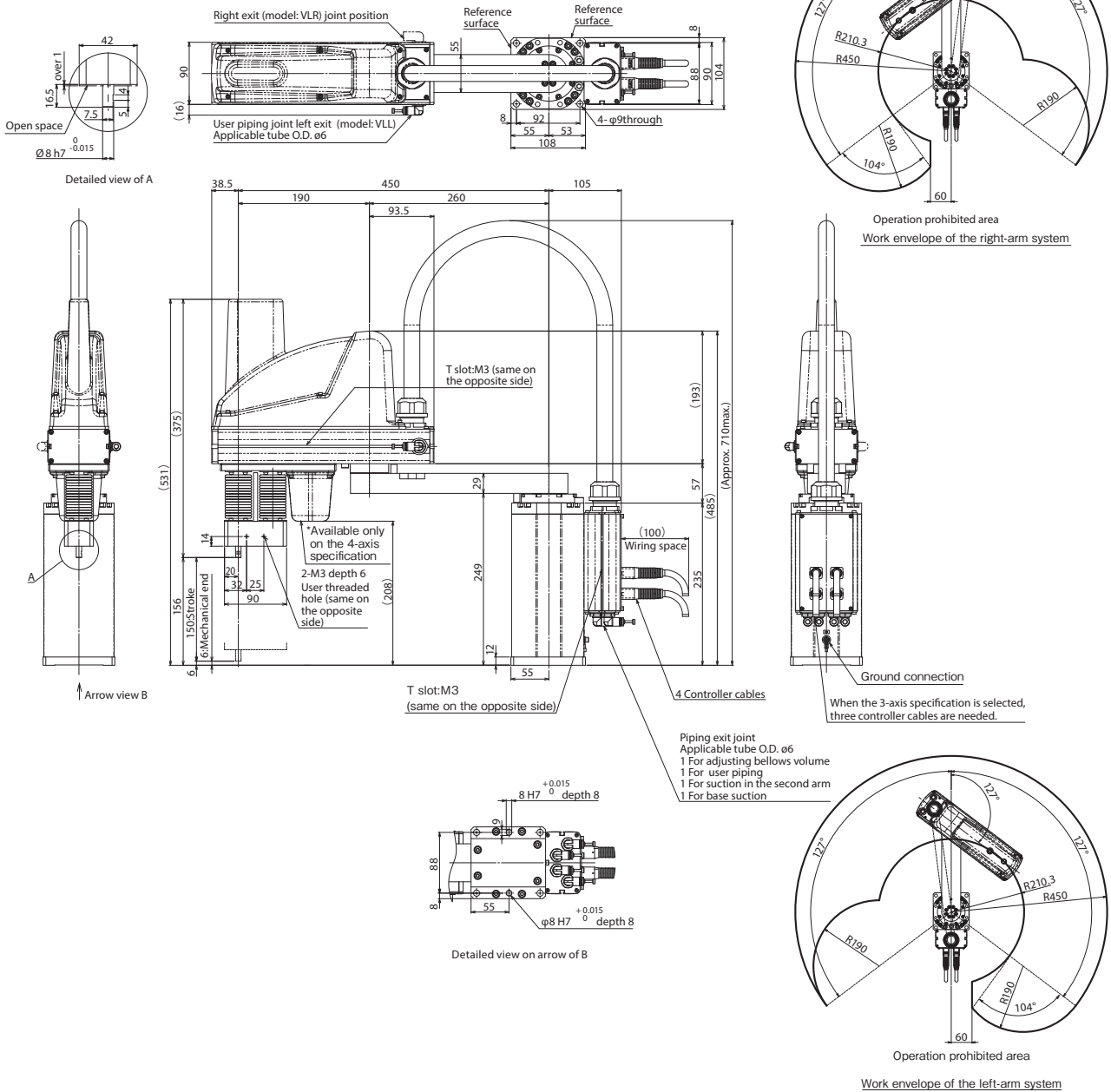

Applicable Controller

IXP series robots can operate with the following controllers. Make sure to select the model depending on the purpose.

Name	External view	Maximum number of controlled axes	Supply voltage	Control method				Max. pos. points	Standard price	Reference page
				Position	Pulse train	Program	Network *Option			
MSEL-PCX/PGX		4	Single-phase 100V ~ 230V	-	-	•	DeviceNet CC-Link EtherNet/IP PROFINET EtherCAT	30000	-	→P37

# IXP- 3C5520/4C5520

Clean room specification

Arm length **550**mm

Vertical axis **200**mm

■ Model Specification Items	IXP	<input type="checkbox"/>	C	55	20	—	WA	<input type="checkbox"/>	—	P3	<input type="checkbox"/>
	Series	Number of axes 3: 3 axes 4: 4 axes	Type C: Cleanroom specification	Arm length 55: 550mm	Vertical axis stroke 20: 200mm	Encoder type WA: Battery-less absolute specification	Cable length N: None P: 1m S: 3m M: 5m	X <input type="checkbox"/> : Specified length R <input type="checkbox"/> : Robot cable Cable length described below Refer to the price list.	Applicable controller P3: MSEL	Option Option below Refer to the price list	

\*Controller is not included. \* Please select VLL or VLR for suction of the L-shaped joint.



\*The photograph shows a 4-axis specification.

**POINT**  
Note on selection

- Refer to P. 7 for \*1 through \*7.
- Make sure to select the brake option when the payload is 4kg or more.
- The vertical axis does not support push-motion control.
- The allowable push force should be 90N under condition of having a buffer such as a spring on a tool or the pressing side.
- Refer to P. 7 for the work envelope, and P. 8 for the notes on acceleration/deceleration setting.

## Robot Specifications

Axis configuration	Arm length (mm)	Work envelope	Positioning repeatability *1	Maximum operating speed in PTP mode *2	Payload (kg) *3	
					Rated	Maximum
Axis 1 Arm 1	260	±127°	±0.04mm	2501mm/s (Composite speed)	2	6
Axis 2 Arm 2	290	±127°				
Axis 3 Vertical axis	—	200mm	±0.02mm	240mm/s		
Axis 4 Rotational axis	—	±360°	±0.02°	700°/s		

## Robot Specifications

	3-axis specification	4-axis specification
Encoder type	Battery-less absolute encoder	
User piping joint	One touch piping joint 1 Applicable tube O.D. ø6	
Standard cycle time *4 (sec)	0.79	
Allowable torque (Axis 4) (N-m)	—	3.06
Allowable moment (N-m)	9.4	
Allowable inertial moment from the tip of the vertical axis *5 (kg-m <sup>2</sup> )	Rated 0.01 Maximum 0.03	Rated 0.01 Maximum 0.01
Ambient operating temperature/humidity	Temperature 0 ~ 40°C Humidity 20 ~ 85%RH (Non-condensing)	
Unit weight (kg)	21	23
Piping joint for suction	One touch piping joint 3 Applicable tubes O.D. ø6	
Suction pressure	-3 ~ -5kPa	
Suction power *7	12Nℓ/min	
cleanliness class	Class10 (Fed. Std. 209D)	
	Equivalent to Class 3.5 (ISO 14644-1)	

## Option price (Standard price)

Name	Option code	Reference page	Standard price
Brake	<b>B</b>	Refer to our ROBO Cylinder General Catalog	—
L-shaped joint left side exit	<b>VLL</b>	→P5	—
L-shaped joint right side exit	<b>VLR</b>	→P5	—

\* Make sure to select this when the transported object is 4kg or more.

## Price List (Standard price)

Specification	Model number	Standard price
3-axis specification	IXP-3C5520	—
4-axis specification	IXP-4C5520	—

## Cable Length (Standard price) <Per Axis\*>

Type	Cable code	Standard price
Standard type	P (1m)	—
	S (3m)	—
	M (5m)	—
Specified length	X06 (6m) ~ X10 (10m)	—
	X11 (11m) ~ X15 (15m)	—
	X16 (16m) ~ X20 (20m)	—
Robot cable	R01 (1m) ~ R03 (3m)	—
	R04 (4m) ~ R05 (5m)	—
	R06 (6m) ~ R10 (10m)	—
	R11 (11m) ~ R15 (15m)	—
	R16 (16m) ~ R20 (20m)	—

\* The 3-axis specification requires three cables, while the gripper specification and 4-axis specification require four cables.



Dimensions



CAD drawings can be downloaded from the website.

www.intelligentactuator.com

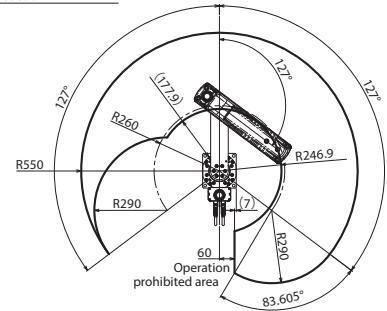
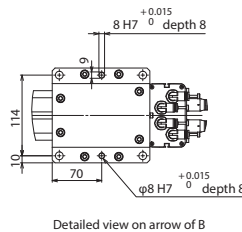
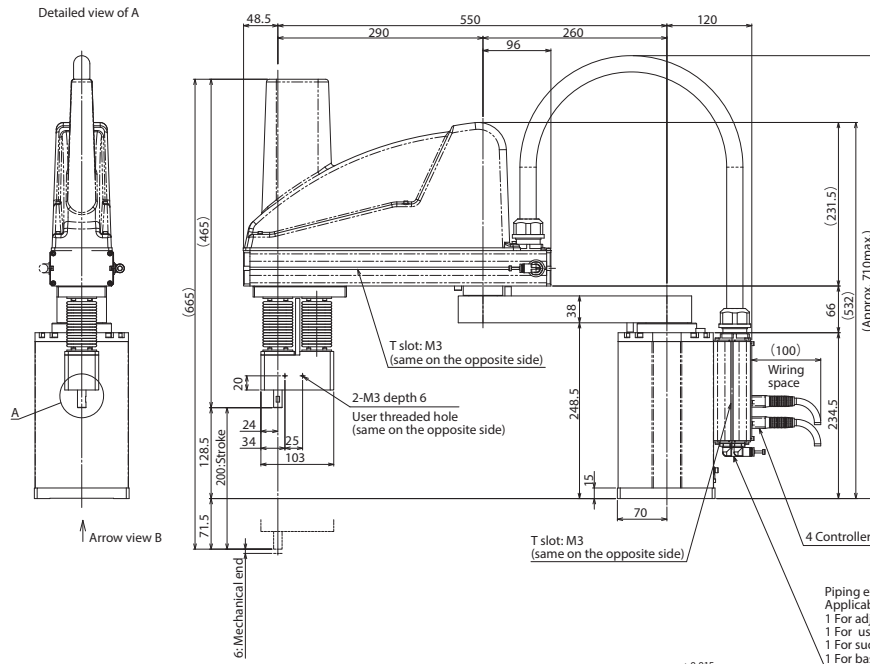
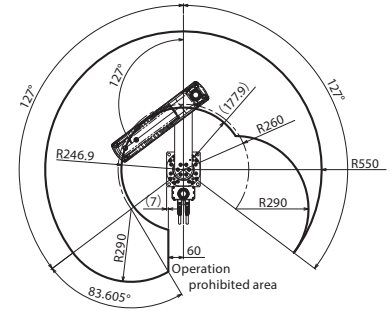
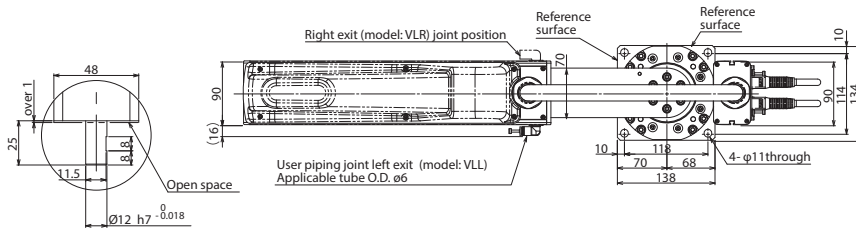

Operation prohibited area  
Work envelope of the left-arm system

Applicable Controller

IXP series robots can operate with the following controllers. Make sure to select the model depending on the purpose.

Name	External view	Maximum number of controlled axes	Supply voltage	Control method				Max. pos. points	Standard price	Reference page
				Position	Pulse train	Program	Network *Option			
MSEL-PCX/PGX		4	Single-phase 100V ~ 230V	-	-	•	DeviceNet CC-Link EtherNet/IP EtherCAT	30000	-	→P37

# IXP- 3C6520/4C6520

Clean room specification

Arm length 650mm

Vertical axis 200mm

■ Model Specification Items	IXP	<input type="checkbox"/>	C	65	20	—	WA	<input type="checkbox"/>	—	P3	<input type="checkbox"/>
	Series	Number of axes 3: 3 axes 4: 4 axes	Type C: Cleanroom specification	Arm length 65: 650mm	Vertical axis stroke 20: 200mm	Encoder type WA: Battery-less absolute specification	Cable length N: None P: 1m S: 3m M: 5m	X <input type="checkbox"/> : Specified length R <input type="checkbox"/> : Robot cable Cable length described below Refer to the price list.	Applicable controller P3: MSEL	Option Option below Refer to the price list	

\* Controller is not included. \* Please select VLL or VLR for suction of the L-shaped joint.



\*The photograph shows a 4-axis specification.

**POINT**  
Note on selection

- Refer to P. 7 for \*1 through \*7.
- Make sure to select the brake option when the payload is 4kg or more.
- The vertical axis does not support push-motion control.
- The allowable push force should be 90N under condition of having a buffer such as a spring on a tool or the pressing side.
- Refer to P. 7 for the work envelope, and P. 8 for the notes on acceleration/deceleration setting.

## Robot Specifications

Axis configuration		Arm length (mm)	Work envelope	Positioning repeatability *1	Maximum operating speed in PTP mode *2	Payload (kg) *3	
						Rated	Maximum
Axis 1	Arm 1	360	±127°	±0.04mm	2314mm/s (Composite speed)	2	6
Axis 2	Arm 2	290	±127°				
Axis 3	Vertical axis	—	200mm	±0.02mm	240mm/s		
Axis 4	Rotational axis	—	±360°	±0.02°	700°/s		

## Robot Specifications

	3-axis specification	4-axis specification
Encoder type	Battery-less absolute encoder	
User piping joint	One touch piping joint 1 Applicable tube O.D. ø6	
Standard cycle time *4 (sec)	0.93	
Allowable torque (Axis 4) (N-m)	—	3.06
Allowable moment (N-m)	9.4	
Allowable inertial moment from the tip of the vertical axis *5 (kg-m <sup>2</sup> )	Rated 0.01 Maximum 0.03	Rated 0.01 Maximum 0.01
Ambient operating temperature/humidity	Temperature 0 ~ 40°C Humidity 20 ~ 85%RH (Non-condensing)	
Unit weight (kg)	24	25
Piping joint for suction	One touch piping joint 3 Applicable tubes O.D. ø6	
Suction pressure	-3 ~ -5kPa	
Suction power *7	12Nℓ/min	
cleanliness class	Class10 (Fed. Std. 209D)	
	Equivalent to Class 3.5 (ISO 14644-1)	

## Option price (Standard price)

Name	Option code	Reference page	Standard price
Brake	<b>B</b>	Refer to our ROBO Cylinder General Catalog	—
L-shaped joint left side exit	<b>VLL</b>	→P5	—
L-shaped joint right side exit	<b>VLR</b>	→P5	—

\* Make sure to select this when the transported object is 4kg or more.

## Price List (Standard price)

Specification	Model number	Standard price
3-axis specification	IXP-3C6520	—
4-axis specification	IXP-4C6520	—

## Cable Length (Standard price) <Per Axis\*>

Type	Cable code	Standard price
Standard type	P (1m)	—
	S (3m)	—
	M (5m)	—
Specified length	X06 (6m) ~ X10 (10m)	—
	X11 (11m) ~ X15 (15m)	—
	X16 (16m) ~ X20 (20m)	—
Robot cable	R01 (1m) ~ R03 (3m)	—
	R04 (4m) ~ R05 (5m)	—
	R06 (6m) ~ R10 (10m)	—
	R11 (11m) ~ R15 (15m)	—
	R16 (16m) ~ R20 (20m)	—

\* The 3-axis specification requires three cables, while the gripper specification and 4-axis specification require four cables.

Dimensions



CAD drawings can be downloaded from the website.

www.intelligentactuator.com

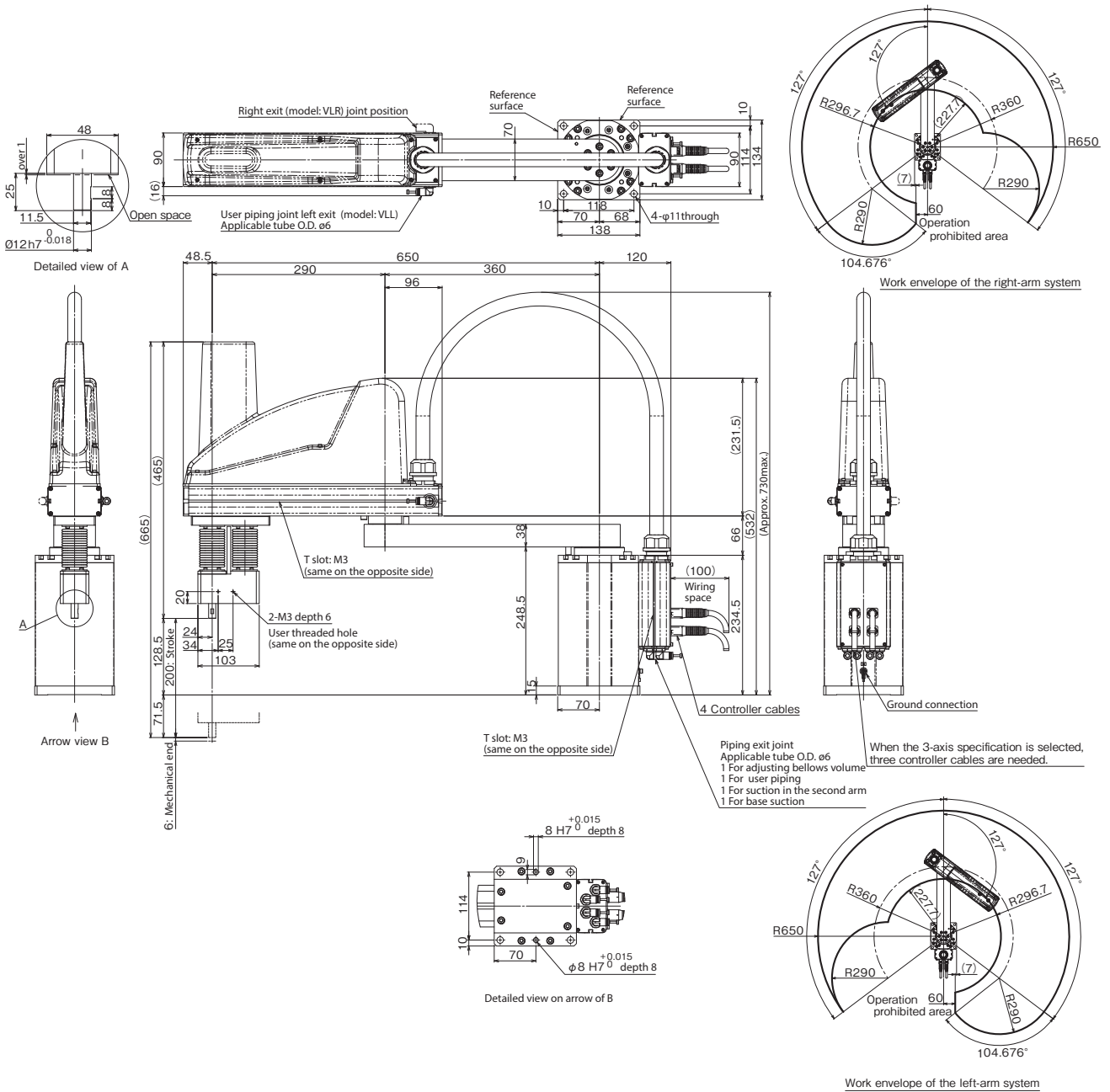

Applicable Controller

IXP series robots can operate with the following controllers. Make sure to select the model depending on the purpose.

Name	External view	Maximum number of controlled axes	Supply voltage	Control method				Max. pos. points	Standard price	Reference page
				Position	Pulse train	Program	Network *Option			
MSEL-PCX/PGX		4	Single-phase 100V ~ 230V	-	-	•	DeviceNet CC-Link EtherNet/IP EtherCAT	30000	-	→P37

# IXP- 3W3515/4W3515

Dust/  
Splash-  
proof  
specification

Arm  
length  
**350**mm

Vertical  
axis  
**150**mm

■ Model Specification Items	IXP	W	35	15	WA		P3
	Series	Number of axes 3: 3 axes 4: 4 axes	Type W: Dust/ Splash-proof specification	Arm length 35: 350mm	Vertical axis stroke 15: 150mm	Encoder type WA: Battery-less absolute specification	Cable length 3L: 3m 5L: 5m Cable length described below Refer to the price list.

\*Controller is not included.



\*The photograph shows a 4-axis specification.

**POINT**  
Note on selection

- Refer to P. 7 for \*1 through \*8.
- The vertical axis has no brake. The unique structure holds the load in place even when the servo is turned off.
- The vertical axis does not support push-motion control.
- The allowable push force is 60N under condition of having a buffer such as a spring on a tool or the pressing side.
- Refer to P. 7 for the work envelope, and P. 8 for the notes on acceleration/deceleration setting.

Robot Specifications							
Axis configuration		Arm length (mm)	Work envelope	Positioning repeatability *1	Maximum operating speed in PTP mode *2	Payload (kg) *3	
						Rated	Maximum
Axis 1	Arm 1	160	±127°	±0.03mm	2399mm/s (Composite speed)	1	3
Axis 2	Arm 2	190	±127°				
Axis 3	Vertical axis	—	150mm	±0.02mm	270mm/s		
Axis 4	Rotational axis	—	±360°	±0.02°	1000°/s		

Robot Specifications		
	3-axis specification	4-axis specification
Encoder type	Battery-less absolute encoder	
Standard cycle time *4 (sec)	0.76	
Allowable torque (Axis 4) (N-m)	—	1.4
Allowable moment (N-m)	2.9	
Allowable inertial moment from the tip of the vertical axis *5 (kg·m <sup>2</sup> )	Rated 0.003 Maximum 0.01	Rated 0.003 Maximum 0.003
Ambient operating temperature/humidity	Temperature 0 ~ 40°C Humidity 20 ~ 85%RH (Non-condensing)	
Unit weight (kg)	17	18
Protection class	IP65	
Piping joint for purge	One touch piping joint Applicable tube O.D. ø6	
Air purge pressure *8	1kPa (Clean dry air)	
Purge flow rate	12Nℓ/min	

Price List (Standard price)		
Specification	Model number	Standard price
3-axis specification	IXP-3W3515	—
4-axis specification	IXP-4W3515	—

Cable Length (Standard price) <Per Unit>	
Cable code	Standard price
3L (3m)	—
5L (5m)	—

Dimensions



CAD drawings can be downloaded from the website.

www.intelligentactuator.com

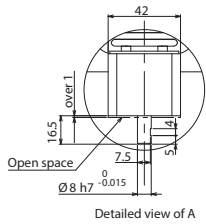

Detailed view of A

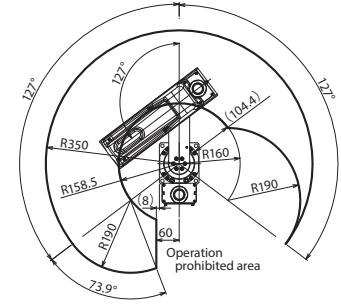
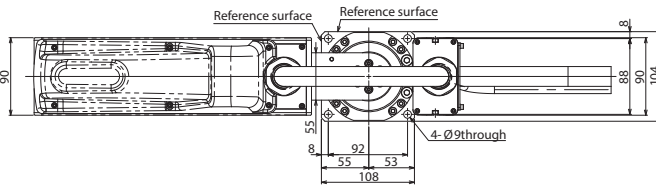

Work envelope of the right-arm system

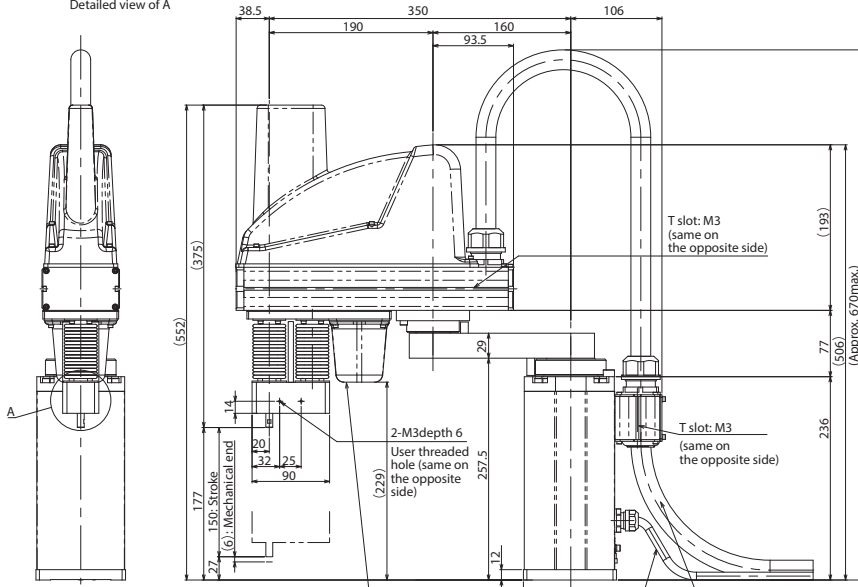

\*Available only on the 4-axis specification.

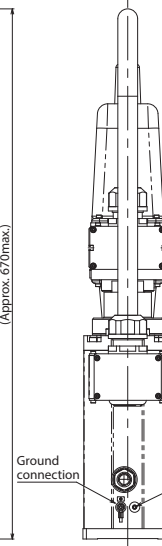

Ground connection

Threaded hole in air joint for base pressure adjustment M6

Arrow view B

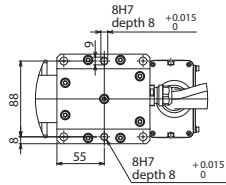

Detailed view on arrow of B

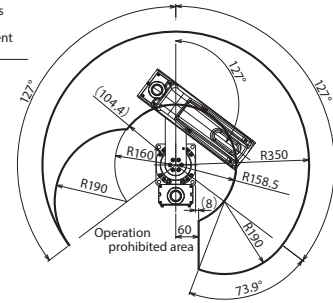

Work envelope of the left-arm system

Applicable Controller

IXP series robots can operate with the following controllers. Make sure to select the model depending on the purpose.

Name	External view	Maximum number of controlled axes	Supply voltage	Control method				Max. pos. points	Standard price	Reference page
				Position	Pulse train	Program	Network *Option			
MSEL-PCX/PGX		4	Single-phase 100V ~ 230V	-	-	•	DeviceNet CC-Link EtherNet/IP PROFINET EtherCAT	30000	-	→P37

# IXP- 3W4515/4W4515

Dust/  
Splash-  
proof  
specification

Arm  
length  
**450mm**

Vertical  
axis  
**150mm**

■ Model Specification Items	IXP	W	45	15	WA		P3
	Series	Number of axes 3: 3 axes 4: 4 axes	Type W: Dust/ Splash-proof specification	Arm length 45: 450mm	Vertical axis stroke 15: 150mm	Encoder type WA: Battery-less absolute specification	Cable length 3L: 3m 5L: 5m Cable length described below Refer to the price list.

\*Controller is not included.



\*The photograph shows a 4-axis specification.

**POINT**  
Note on selection

- Refer to P. 7 for \*1 through \*8.
- The vertical axis has no brake. The unique structure holds the load in place even when the servo is turned off.
- The vertical axis does not support push-motion control.
- The allowable push force is 60N under condition of having a buffer such as a spring on a tool or the pressing side.
- Refer to P. 7 for the work envelope, and P. 8 for the notes on acceleration/deceleration setting.

## Robot Specifications

Axis configuration	Arm length (mm)	Work envelope	Positioning repeatability *1	Maximum operating speed in PTP mode *2	Payload (kg) *3	
					Rated	Maximum
Axis 1	Arm 1	±127°	±0.03mm	2194mm/s (Composite speed)	1	3
Axis 2	Arm 2	±127°				
Axis 3	Vertical axis	150mm	±0.02mm	270mm/s		
Axis 4	Rotational axis	±360°	±0.02°	1000°/s		

## Robot Specifications

	3-axis specification	4-axis specification
Encoder type	Battery-less absolute encoder	
Standard cycle time *4 (sec)	0.74	
Allowable torque (Axis 4) (N-m)	—	1.4
Allowable moment (N-m)	2.9	
Allowable inertial moment from the tip of the vertical axis *5 (kg·m <sup>2</sup> )	Rated 0.003 Maximum 0.01	Rated 0.003 Maximum 0.003
Ambient operating temperature/humidity	Temperature 0 ~ 40°C Humidity 20 ~ 85%RH (Non-condensing)	
Unit weight (kg)	18	19
Protection class	IP65	
Piping joint for purge	One touch piping joint Applicable tube O.D. ø6	
Air purge pressure *8	1kPa (Clean dry air)	
Purge flow rate	12Nℓ/min	

## Price List (Standard price)

Specification	Model number	Standard price
3-axis specification	IXP-3W4515	—
4-axis specification	IXP-4W4515	—

## Cable Length (Standard price) <Per Unit>

Cable code	Standard price
3L (3m)	—
5L (5m)	—



Dimensions



CAD drawings can be downloaded from the website. [www.intelligentactuator.com](http://www.intelligentactuator.com)

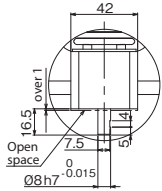

Detailed view of A

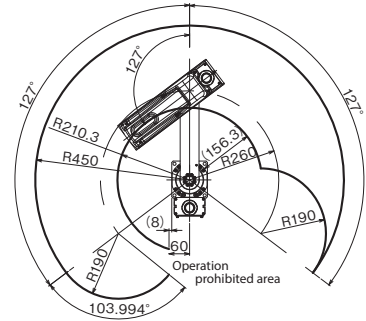
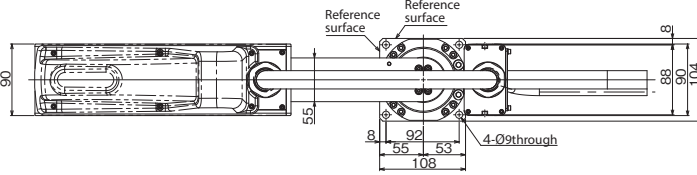

Work envelope of the right-arm system

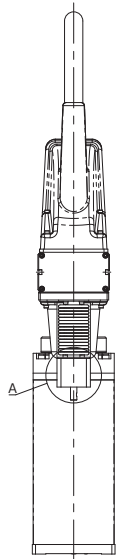

Arrow view B

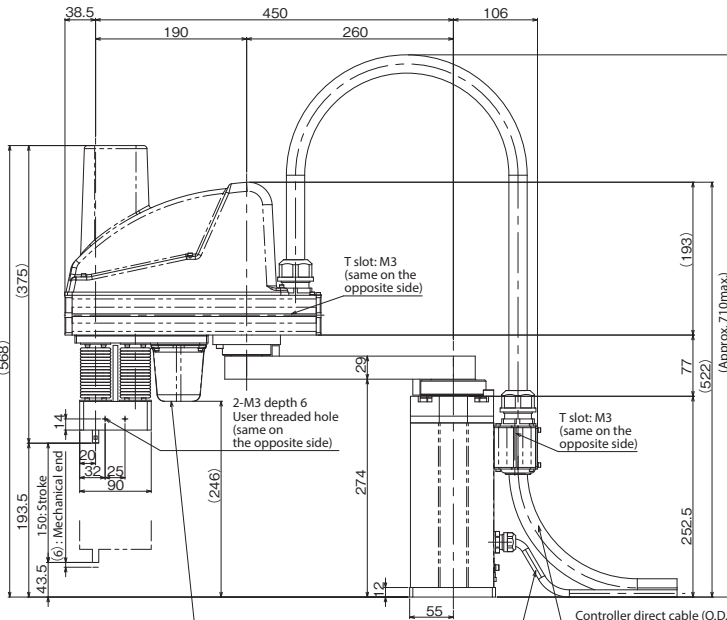

\*Available only on the 4-axis specification.

Controller direct cable (O.D. 9.1) Motor / encoder wiring for first arm

Controller direct cable (O.D. 23) Motor / encoder wiring for Z axis and R axis in the second arm  
Air piping for pressure adjustment in the second arm Ø6x3

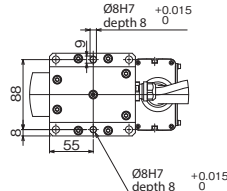

Detailed view on arrow of B

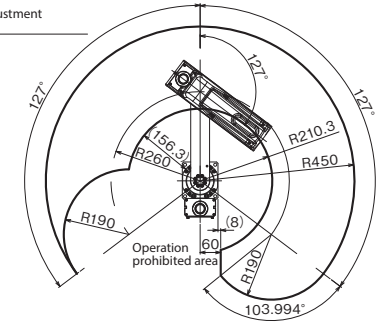

Work envelope of the left-arm system

Applicable Controller

IXP series robots can operate with the following controllers. Make sure to select the model depending on the purpose.

Name	External view	Maximum number of controlled axes	Supply voltage	Control method				Max. pos. points	Standard price	Reference page
				Position	Pulse train	Program	Network *Option			
MSEL-PCX/PGX		4	Single-phase 100V ~ 230V	-	-	•	DeviceNet CC-Link EtherNet/IP EtherCAT	30000	-	→P37

# IXP- 3W5520/4W5520

Dust/  
Splash-  
proof  
specification

Arm  
length  
**550**mm

Vertical  
axis  
**200**mm

■ Model Specification Items	<b>IXP</b>	<input type="checkbox"/>	<b>W</b>	<b>55</b>	<b>20</b>	<b>WA</b>	<input type="checkbox"/>	<b>P3</b>	<input type="checkbox"/>
	Series	Number of axes 3: 3 axes 4: 4 axes	Type W: Dust/ Splash-proof specification	Arm length 55: 550mm	Vertical axis stroke 20: 200mm	Encoder type WA: Battery-less absolute specification	Cable length 3L: 3m 5L: 5m	Cable length described below Refer to the price list.	Applicable controller P3: MSEL

\*Controller is not included. \* Please select VLL or VLR for suction of the L-shaped joint.



\*The photograph shows a 4-axis specification.

**POINT**  
Note on selection

- Refer to P. 7 for \*1 through \*8.
- Make sure to select the brake option when the payload is 4kg or more.
- The vertical axis does not support push-motion control.
- The allowable push force should be 90N under condition of having a buffer such as a spring on a tool or the pressing side.
- Refer to P. 7 for the work envelope, and P. 8 for the notes on acceleration/deceleration setting.

Robot Specifications							
Axis configuration		Arm length (mm)	Work envelope	Positioning repeatability *1	Maximum operating speed in PTP mode *2	Payload (kg) *3	
						Rated	Maximum
Axis 1	Arm 1	260	±127°	±0.04mm	2501mm/s (Composite speed)	2	6
Axis 2	Arm 2	290	±127°				
Axis 3	Vertical axis	—	200mm	±0.02mm	240mm/s		
Axis 4	Rotational axis	—	±360°	±0.02°	700°/s		

Robot Specifications		
	3-axis specification	4-axis specification
Encoder type	Battery-less absolute encoder	
Standard cycle time *4 (sec)	0.79	
Allowable torque (Axis 4) (N-m)	—	3.06
Allowable moment (N-m)	9.4	
Allowable inertial moment from the tip of the vertical axis *5 (kg-m <sup>2</sup> )	Rated 0.01 Maximum 0.03	Rated 0.01 Maximum 0.01
Ambient operating temperature/humidity	Temperature 0 ~ 40°C Humidity 20 ~ 85%RH (Non-condensing)	
Unit weight (kg)	25	27
Protection class	IP65	
Piping joint for purge	One touch piping joint Applicable tube O.D. ø6	
Air purge pressure *8	1kPa (Clean dry air)	
Purge flow rate	12Nℓ/min	

Price List (Standard price)		
Specification	Model number	Standard price
3-axis specification	IXP-3W5520	—
4-axis specification	IXP-4W5520	—

Cable Length (Standard price) <Per Unit>	
Cable code	Standard price
3L (3m)	—
5L (5m)	—

Option price (Standard price)			
Name	Option code	Reference page	Standard price
Brake	<b>B</b>	Refer to our ROBO Cylinder General Catalog	—

\* Make sure to select this when the transported object is 4kg or more.

Dimensions



CAD drawings can be downloaded from the website.

www.intelligentactuator.com

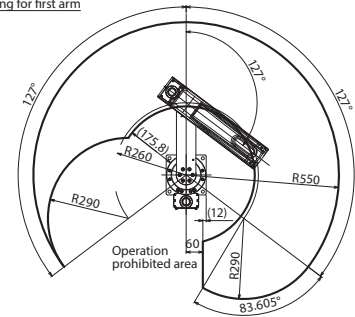
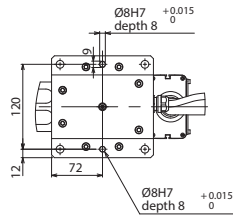
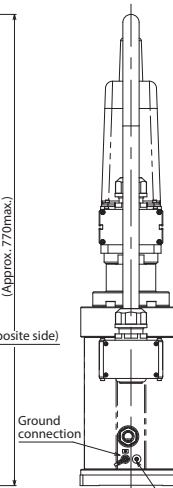
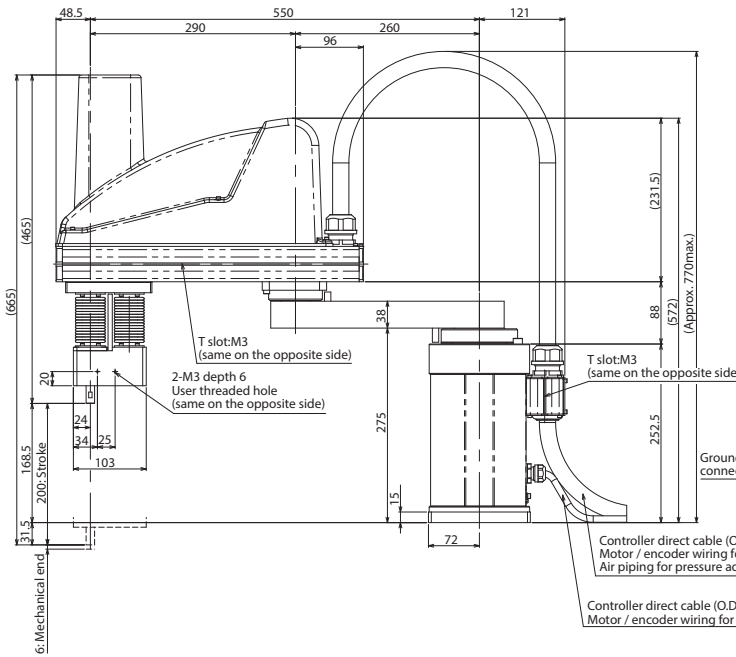
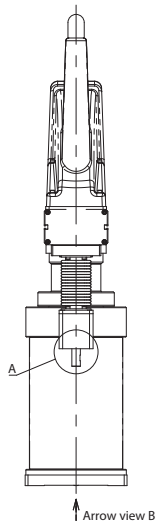
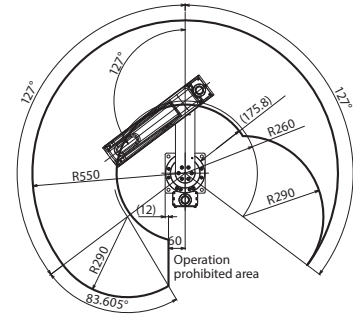
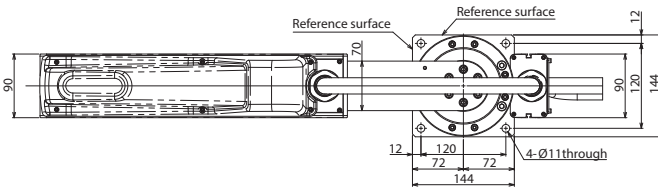
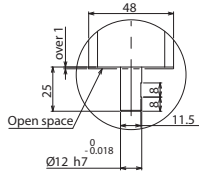

Applicable Controller

IXP series robots can operate with the following controllers. Make sure to select the model depending on the purpose.

Name	External view	Maximum number of controlled axes	Supply voltage	Control method				Max. pos. points	Standard price	Reference page
				Position	Pulse train	Program	Network *Option			
MSEL-PCX/PGX		4	Single-phase 100V ~ 230V	-	-	•	DeviceNet CC-Link EtherNet/IP EtherCAT	30000	-	→P37

# IXP- 3W6520/4W6520

Dust/  
Splash-  
proof  
specification

Arm  
length  
**650**mm

Vertical  
axis  
**200**mm

■ Model Specification Items	IXP	W	65	20	WA	P3		
	Series	Number of axes 3: 3 axes 4: 4 axes	Type W: Dust/ Splash-proof specification	Arm length 65: 650mm	Vertical axis stroke 20: 200mm	Encoder type WA: Battery-less absolute specification	Cable length 3L: 3m 5L: 5m Cable length described below Refer to the price list.	Applicable controller P3: MSEL

\*Controller is not included.



\*The photograph shows a 4-axis specification.

**POINT**  
Note on selection

- Refer to P. 7 for \*1 through \*8.
- Make sure to select the brake option when the payload is 4kg or more.
- The vertical axis does not support push-motion control.
- The allowable push force should be 90N under condition of having a buffer such as a spring on a tool or the pressing side.
- Refer to P. 7 for the work envelope, and P. 8 for the notes on acceleration/deceleration setting.

Robot Specifications							
Axis configuration		Arm length (mm)	Work envelope	Positioning repeatability *1	Maximum operating speed in PTP mode *2	Payload (kg) *3	
						Rated	Maximum
Axis 1	Arm 1	360	±127°	±0.04mm	2314mm/s (Composite speed)	2	6
Axis 2	Arm 2	290	±127°				
Axis 3	Vertical axis	—	200mm	±0.02mm	240mm/s		
Axis 4	Rotational axis	—	±360°	±0.02°	700°/s		

Robot Specifications		
	3-axis specification	4-axis specification
Encoder type	Battery-less absolute encoder	
Standard cycle time *4 (sec)	0.93	
Allowable torque (Axis 4) (N-m)	—	3.06
Allowable moment (N-m)	9.4	
Allowable inertial moment from the tip of the vertical axis *5 (kg-m <sup>2</sup> )	Rated 0.01 Maximum 0.03	Rated 0.01 Maximum 0.01
Ambient operating temperature/humidity	Temperature 0 ~ 40°C Humidity 20 ~ 85%RH (Non-condensing)	
Unit weight (kg)	27	29
Protection class	IP65	
Piping joint for purge	One touch piping joint Applicable tube O.D. ø6	
Air purge pressure *8	1kPa (Clean dry air)	
Purge flow rate	12Nℓ/min	

Price List (Standard price)		
Specification	Model number	Standard price
3-axis specification	IXP-3W6520	—
4-axis specification	IXP-4W6520	—

Cable Length (Standard price) <Per Unit>	
Cable code	Standard price
3L (3m)	—
5L (5m)	—

Option price (Standard price)			
Name	Option code	Reference page	Standard price
Brake	<b>B</b>	Refer to our ROBO Cylinder General Catalog	—

\* Make sure to select this when the transported object is 4kg or more.

Dimensions



CAD drawings can be downloaded from the website.

[www.intelligentactuator.com](http://www.intelligentactuator.com)

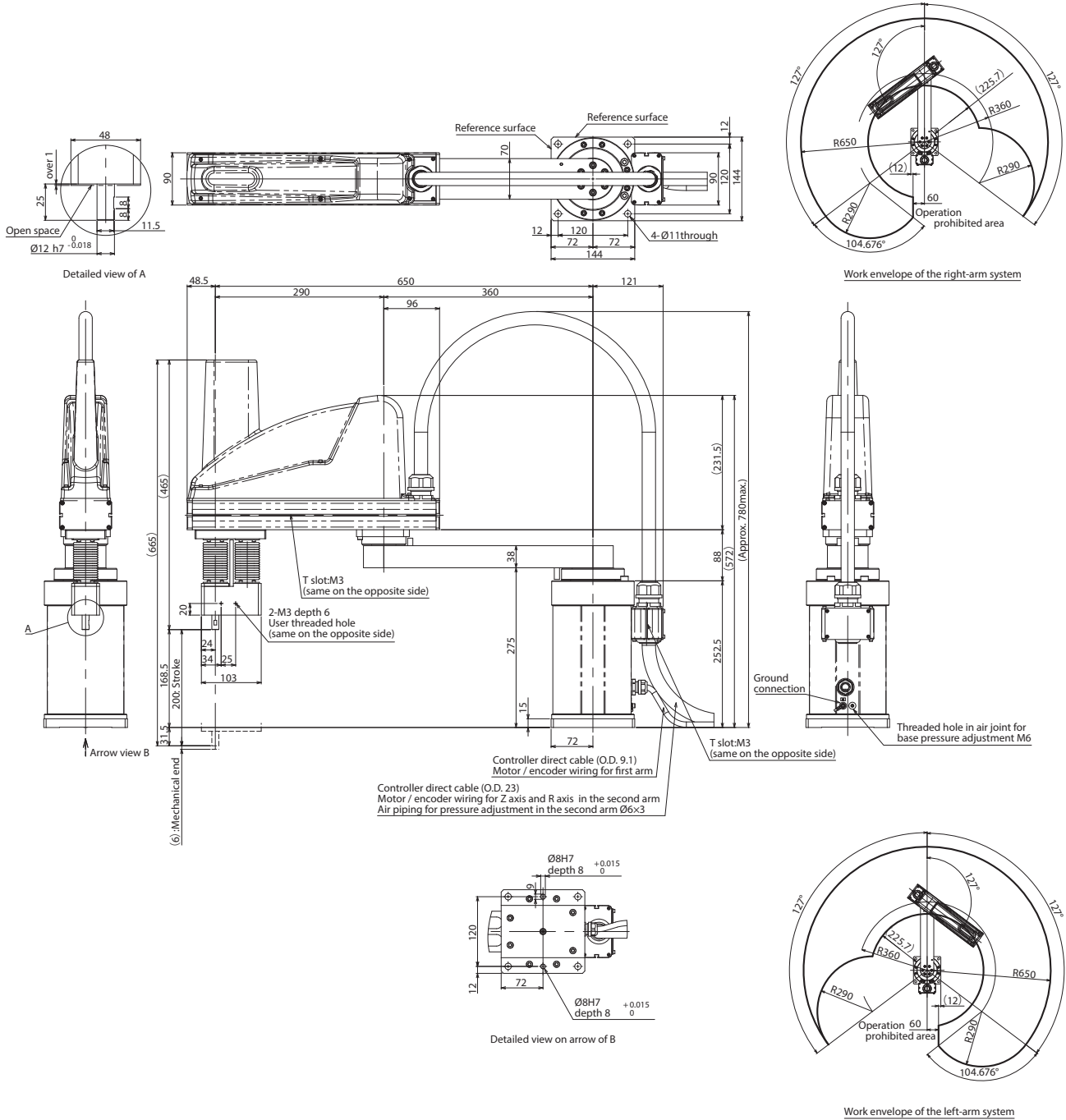

Applicable Controller

IXP series robots can operate with the following controllers. Make sure to select the model depending on the purpose.

Name	External view	Maximum number of controlled axes	Supply voltage	Control method				Max. pos. points	Standard price	Reference page
				Position	Pulse train	Program	Network *Option			
MSEL-PCX/PGX		4	Single-phase 100V ~ 230V	-	-	•	DeviceNet CC-Link EtherNet/IP PROFINET EtherCAT	30000	-	→P37

# MSEL

## MSEL-PCX/PGX Program Controllers for PowerCON SCARA



### Model List

Name	Controllers for PowerCON SCARA			
External view				
Type name	PCX3	PGX3	PCX4	PGX4
Type	3-axis standard specification	3-axis safety category compliant specification	4-axis standard specification	4-axis safety category compliant specification
Standard price	—	—	—	—
Connected actuator	IXP 3-axis specification		IXP 3-axis specification + additional axis (including gripper specification) IXP 4-axis specification	
Standard I/O	NPN, PNP (16IN/16OUT)			
Expansion I/O	NPN, CC-Link, DeviceNet, PROFIBUS-DP, EtherNet/IP, EtherCAT, PROFINET, RS232C, RS485C, IA network			
Number of positions	30,000			
Power-supply voltage	Single-phase AC100 ~ 230V			

### Model

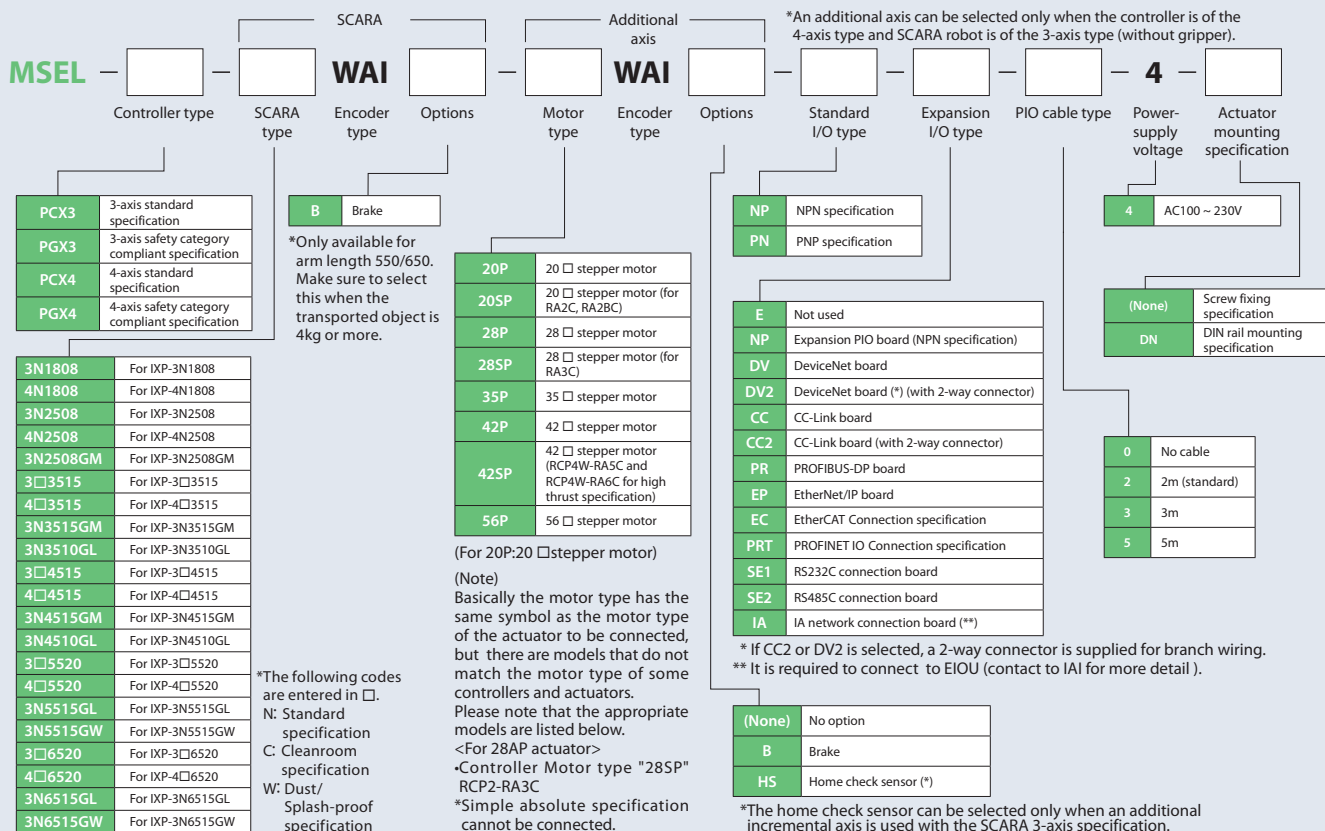



System Configuration

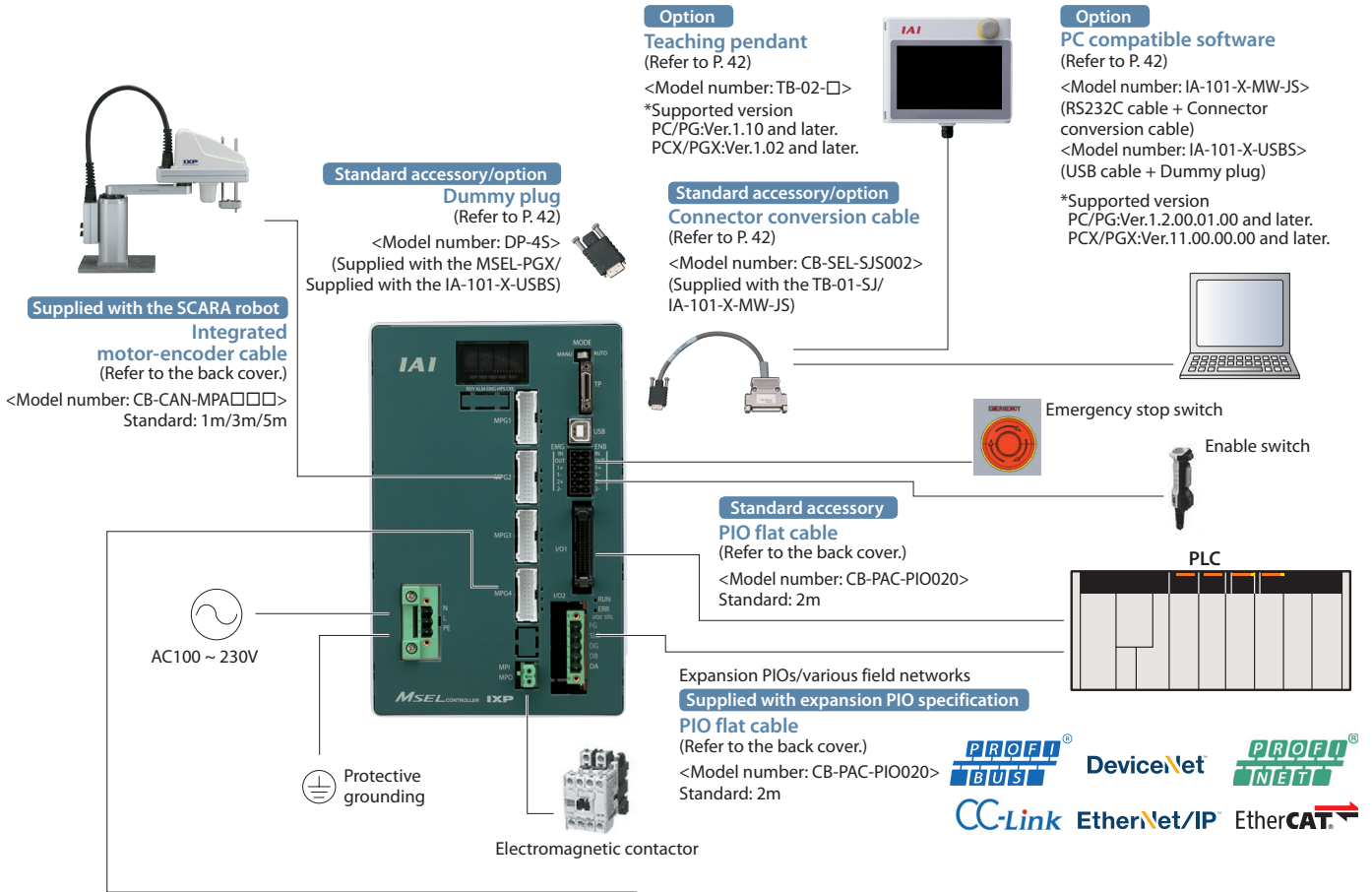

<Actuator for Additional Axis>  
 (Can be connected to a SCARA robot of 3-axis specification)

\*Wire the emergency stop switch, enable switch, electromagnetic contactor, etc., as necessary. The same applies to the factory settings (shorting).

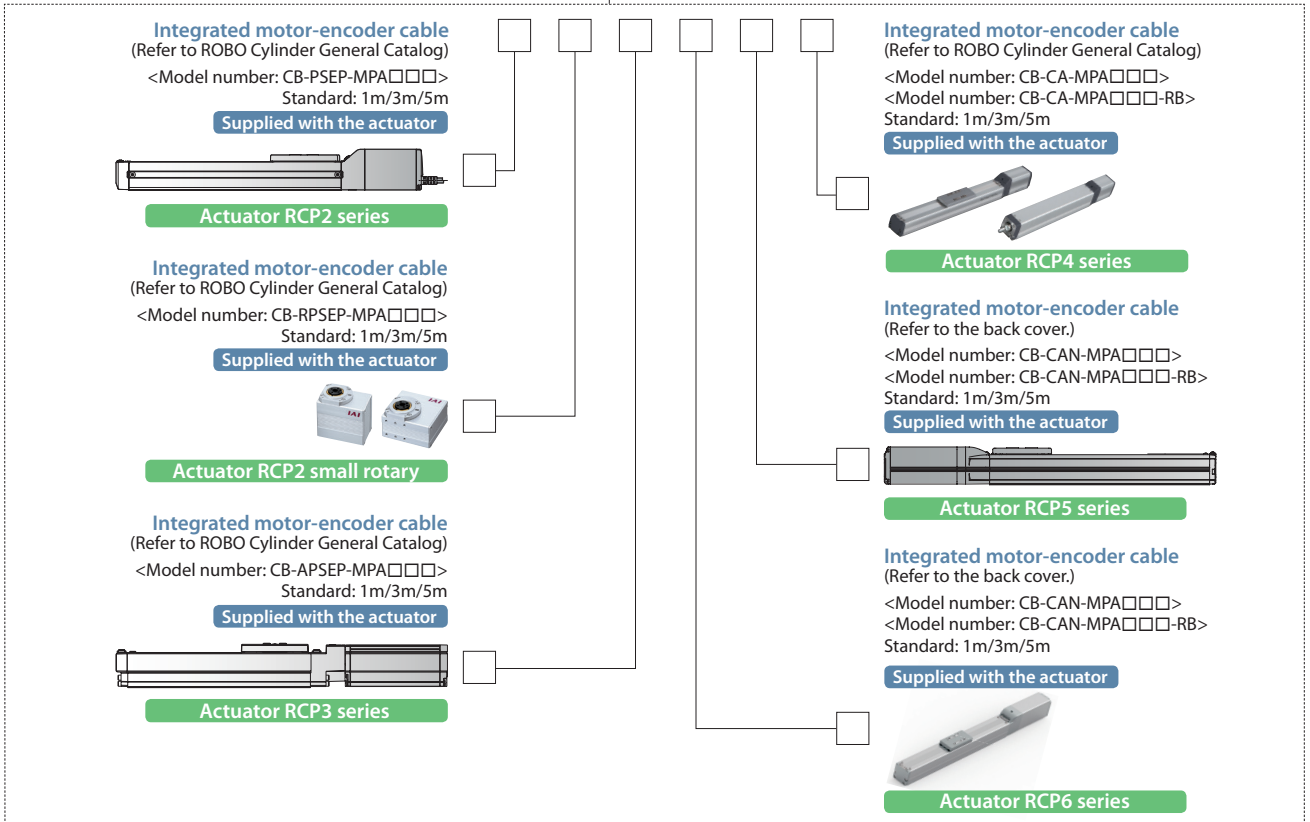

**Basic Controller Specifications**

Specification item		Contents	
Power-supply input voltage		Single-phase AC100 ~ 230V ±10%	
Power-supply current		2.9A typ. (AC100V), 1.4A typ. (AC200V), 1.2A typ. (AC230V)	
Power-supply frequency range		50/60Hz±5%	
Motor type		Stepper motor (servo control)	
Supported encoder		Incremental encoder / Battery-less absolute encoder	
Data storage device		FlashROM/FRAM	
Number of program steps		9,999	
Number of positions		30,000	
Number of programs		255	
Number of multi-tasks		16	
Operation mode	Serial communications	○	
	Program	○	
SIO interface	Communication method		RS232 (asynchronous communications)
	Baud rate		9.6, 19.2, 38.4, 57.6, 76.8, 115.2kbps
	Live wire connection	TP port	×
		USB	○
Standard PIO interface	Input Specification	Number of input points	16 points
		Input voltage	DC24V±10%
		Input current	7mA/circuit
		ON voltage	DC16V Min.
		OFF voltage	DC5V Max.
		Leak current	Allowable leak current: 1mA max.
		Insulation method	Photocoupler insulation
	Output specification	Number of output points	16 points
		Load voltage	DC24V±10%
		Maximum current	100mA per point, 400mA per 8 points (Note 1)
		Saturated voltage	3V Max.
		Leak current	0.1mA Max.
		Insulation method	Photocoupler insulation
		Compliant expansion I/O interface	
Calendar/clock function	Retention time	Approx. 10 days	
	Charge time	Approx. 100 hours (fully charged) * Data can be retained even when the batteries are not fully charged.	
Protective functions		Overcurrent, abnormal temperature, low fan speed monitoring, encoder disconnection, etc.	
Operating temperature range		0 ~ 40°C	
Operating humidity range		85% RH max. (non-condensing, non-freezing)	
Installation	Installation direction	Installed vertically (exhaust side up)	
	Installation method	Mounted with screws or using a DIN rail	
Rush current		15A typ. (AC100 V), 30A typ. (AC200 V): 5ms max. (Ambient temperature 25°C/No cycling of the power)	
Air cooling method		Forced air cooling	
External dimensions		Width 130mm x Height 195mm x Depth 125mm	
Mass		Approx. 1,400g	

(Note 1) The total load current shall be 400mA for every eight points from standard I/O No. 316. (The maximum current per point shall be 100mA.)

## PIO Signal Chart

Pin layouts for standard PIO connector/expansion PIO connector

Pin No.	Category	Assignment	Pin No.	Category	Assignment
1A	24V	P24	1B	Output	OUT0
2A	24V	P24	2B		OUT1
3A	—	—	3B		OUT2
4A	—	—	4B		OUT3
5A	Input	IN0	5B		OUT4
6A		IN1	6B		OUT5
7A		IN2	7B		OUT6
8A		IN3	8B		OUT7
9A		IN4	9B		OUT8
10A		IN5	10B		OUT9
11A		IN6	11B		OUT10
12A		IN7	12B		OUT11
13A		IN8	13B		OUT12
14A		IN9	14B		OUT13
15A		IN10	15B		OUT14
16A		IN11	16B	OUT15	
17A		IN12	17B	—	
18A		IN13	18B	—	
19A	IN14	19B	0V	N	
20A	IN15	20B	0V	N	

## Internal Circuits for Standard I/Os (NPN Specifications)

[Input section] External input specifications (NPN specifications)

Item	Specifications
Input voltage	DC24V ±10%
Input current	7mA/circuit
On/Off voltage	On voltage: DC16.0V min. Off voltage: DC5.0V max.
Insulation method	Photocoupler insulation

\* The port numbers in the circuit diagram below represent the factory-set port numbers.  
 \* When the input is off, the allowable leak current is 1mA max.

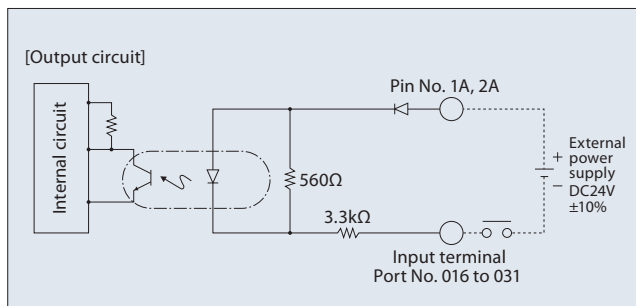

\* For the standard IOs (PNP specifications), refer to the operation manual.

[Output section] External output specifications (NPN specifications)

Item	Specifications	
Load voltage	DC24V ±10%	Uses TD62084 (or equivalent).
Maximum load current	100mA/point, 400mA/8 points Note)	
Leak current	0.1mA/point max.	
Insulation method	Photocoupler insulation	

\* The port numbers in the circuit diagram below represent the factory-set port numbers.  
 Note: The total load current shall be 400 mA for every eight points from standard I/O No. 316. (The maximum current per point shall be 100mA.)

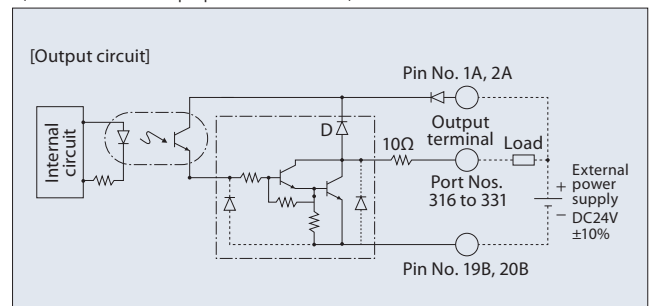

## Internal Circuits for Expansion I/Os (NPN Specifications)

[Input section] External input specifications

Item	Specifications
Number of input points	16 points
Input voltage	DC24V ±10%
Input current	4mA/circuit
On/Off voltage	On voltage: DC18V (3.5mA) min. Off voltage: DC6V (1mA) max.
Insulation method	Photocoupler insulation

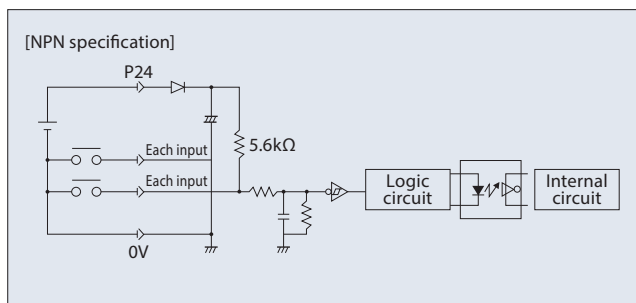

\* For the standard IOs (PNP specifications), refer to the operation manual.

[Output section] External output specifications

Item	Specifications
Number of output points	16 points
Rated load current	DC24V ±10%
Maximum current	50mA/circuit
Insulation method	Photocoupler insulation

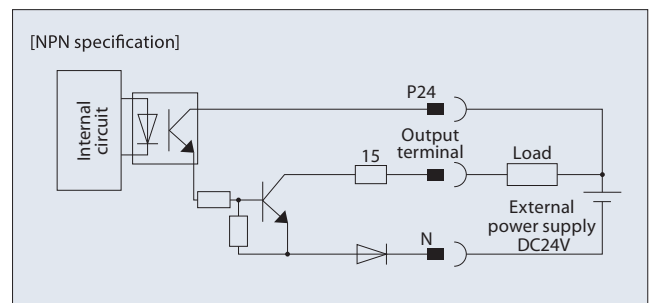

## Name of Each Part

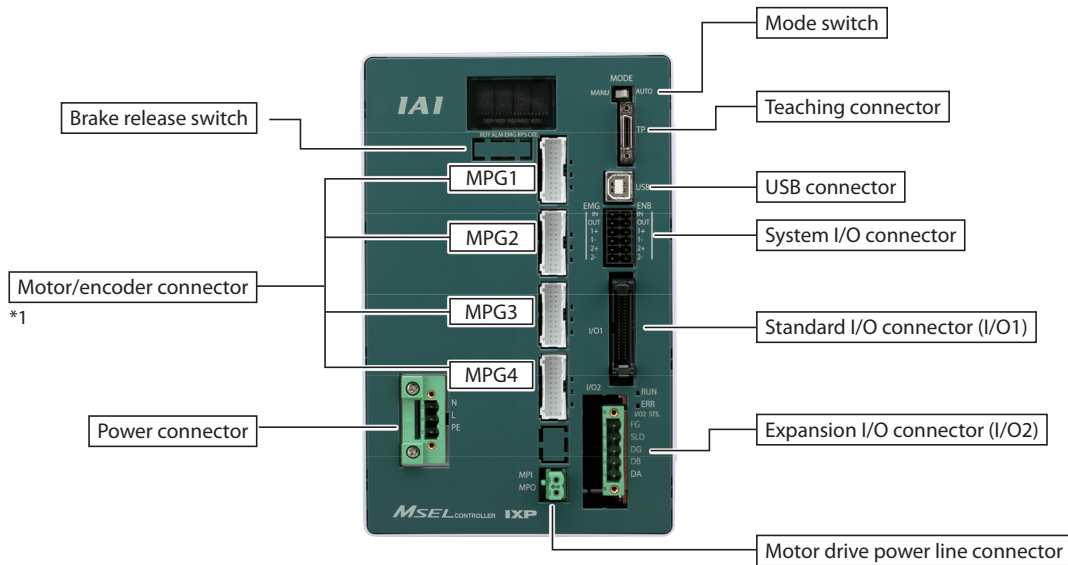

\*1: Do not connect a wrong motor to the MPG1, MPG2, MPG3 or MPG4 connector. It may cause malfunction or failure.

## External dimensions

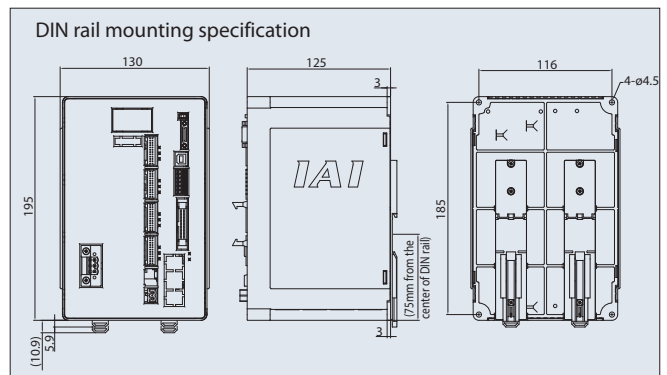
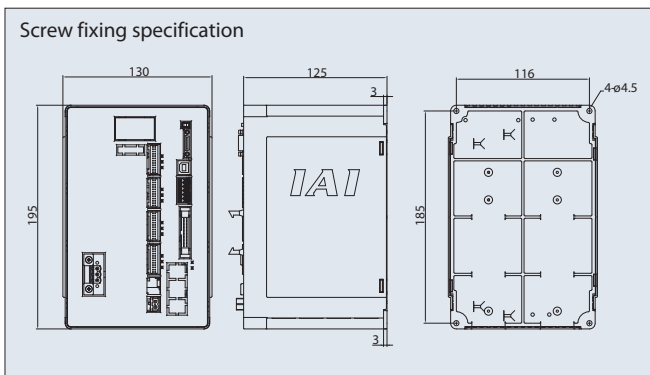

## Options

### Flange

Features: It is a tool used to attach an object on the arm tip on the Z-axis.

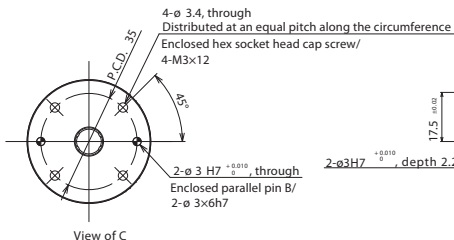
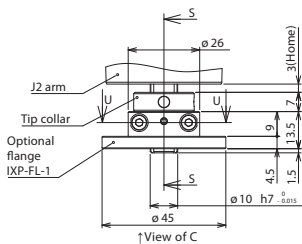

IXP-FL-1 (For 1808/2508)

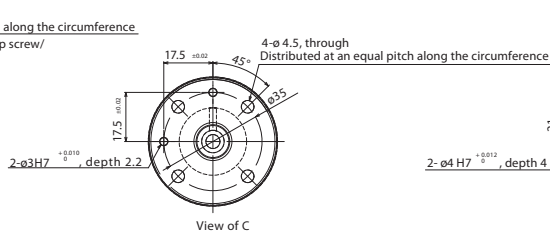
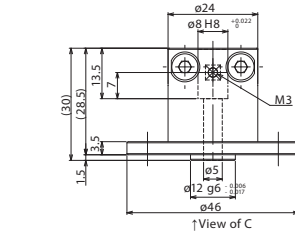

IXP-FL-2 (For 3515/3510/4515/4510)

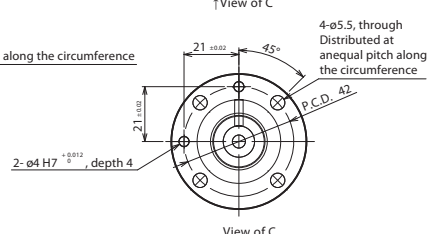
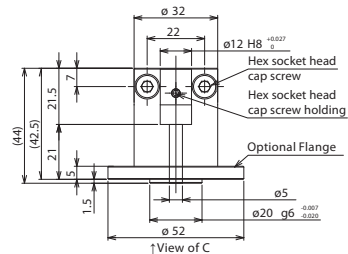

IXP-FL-3 (For 5520/5515/6520/6515)

Model number	Standard price	Weight
IXP-FL-1	—	80g

Model number	Standard price	Weight
IXP-FL-2	—	120g

Model number	Standard price	Weight
IXP-FL-3	—	290g

Options

Touch panel teaching pendant

**Features:** Teaching device for positioning input, test operation, and monitoring.

**Model number:** TB-02-□

**Configuration:**

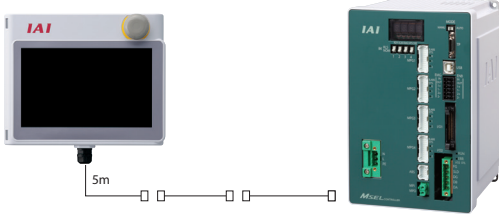

**Specifications**

Rated voltage	24V DC
Power consumption	3.6W or less (150mA or less)
Ambient operating temperature	0~40°C
Ambient operating humidity	20~85%RH (Non-condensing)
Environmental resistance	IP20
Weight	470g (only TB-02 unit)

Dummy Plug

**Features:**

This plug is required for the safety category specification (MSEL-PGX) and when the MSEL is operated using a USB cable. (The MSEL-PGX type and PC compatible software IA-101-X-USBS comes with this dummy plug.)

**Model number:** DP-4S



Connector Conversion Cable

**Features:**

This cable is used to convert the D-sub 25-pin connector of the teaching pendant or RS232C cable to the MSEL teaching connector. (The TB-01-SJ and IA-101-X-MW-JS comes with this connector conversion cable.)

**Model number:** CB-SEL-SJS002

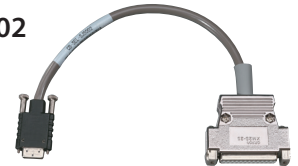

PC Compatible Software (Windows Only)

**Features:**

The startup support software provides program/position input, test operation and monitoring functions, among others. With its enhanced functions required for debugging, this software helps shorten the startup time.

**Model number:** IA-101-X-MW-JS (RS232C cable + Connector conversion cable)

**Configuration:**

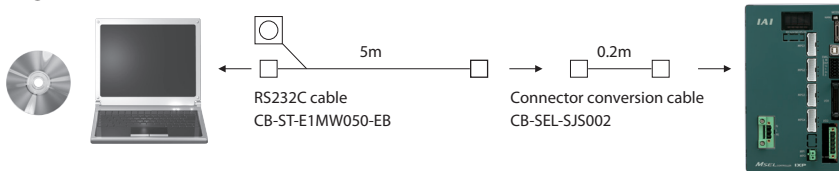

**Model number:** IA-101-X-USBS (USB cable + Dummy plug)

**Configuration:**

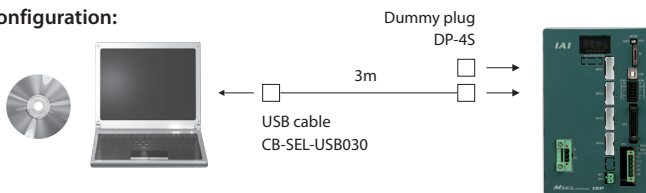

Windows :  
XP SP2/Vista/7/8 /10 or later

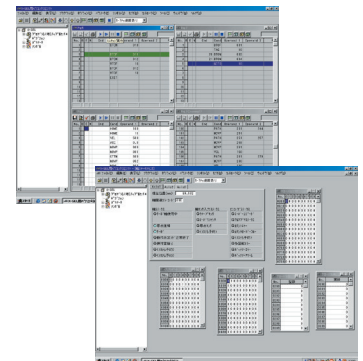

The MSEL-PCX/PGX are supported by  
Ver. 11.00.00.00 or later.

The CB-ST-E1MW050-EB cannot be used when "Building an enable system that uses a system I/O connector and external power supply" or "Building a redundant safety circuit." (The CB-ST-A1MW050-EB must be used instead.)

**Service Parts**

Please refer to the models listed below when arrangements such as cable replacement are needed after purchasing the product.

(Check in the general catalog for the cable for added axis.)

<b>Model Number</b>	<b>CB-CAN-MPA</b> □□□	<b>Integrated Motor-Encoder Cable</b>	<b>for</b>
	<b>CB-CAN-MPA</b> □□□- <b>RB</b>	<b>Integrated Motor-Encoder Robot Cable</b>	<b>IXP/RCP4-SA3/RA3/RCP5</b>

\* Please indicate cable length (L) in □□□, (e.g. 080 = 8m) maximum 20m.

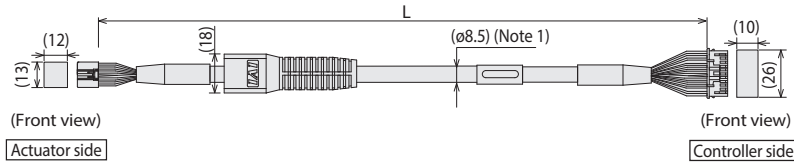

Minimum bending radius 5m or less length R = 68mm or more (Dynamic bending condition)  
 Longer than 5m R = 73mm or more (Dynamic bending condition)

\* The robot cable is designed for flex-resistance: Please use the robot cable if the cable has to be installed through a cable track.

(Note 1) If the cable is 5m or longer, ø9.1 cable diameter applies for a non-robot cable and ø10 for a robot cable.

Pin No.	Signal name	Pin No.	Signal name
3	φA/U	1	φA
5	VMM/V	2	VMM
10	φ A/W	3	φB
9	φB/-	4	VMM
4	VMM/-	5	φ A
15	φ B/-	6	φ B
8	LS+/BK+	7	LS+
14	LS-/BK-	5	LS-
12	-/A+	11	SA (mABS)
17	-/A-	12	SB (mABS)
1	A+/B+	13	A+
6	A-/B-	14	A-
11	B+/Z+	15	B+
16	B-/Z-	16	B-
20	BK+/LS+	9	BK+
2	BK-/LS-	10	BK-
21	LS_GND	17	VCC
7	VPS	19	GND
15	VCC	15	VPS
13	GND	20	LS_GND
19	—	22	—
22	BAT+	21	— (CFvcc)
23	—	23	—
24	FG	24	FG

<b>Model Number</b>	<b>CB-PAC-PIO</b> □□□	<b>PIO Flat Cable</b>	<b>for</b>
			<b>MSEL/PCON-CA/MSEP-LC</b>

\* Please indicate cable length (L) in □□□, (e.g. 080 = 8m) maximum 10m.

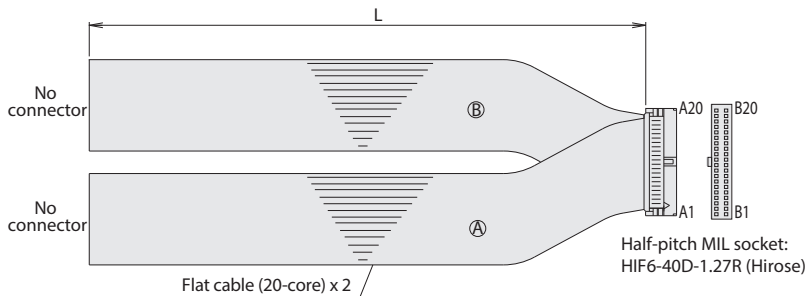

HIF6-40D-1.27R

No.	Signal name	Cable color	Wiring	No.	Signal name	Cable color	Wiring
A1	24V	Brown-1	Flat cable (A) (crimped) AWG28	B1	OUT0	Brown-3	Flat cable (B) (crimped) AWG28
A2	24V	Red-1		B2	OUT1	Red-3	
A3	—	Orange-1		B3	OUT2	Orange-3	
A4	—	Yellow-1		B4	OUT3	Yellow-3	
A5	IN0	Green-1		B5	OUT4	Green-3	
A6	IN1	Blue-1		B6	OUT5	Blue-3	
A7	IN2	Purple-1		B7	OUT6	Purple-3	
A8	IN3	Gray-1		B8	OUT7	Gray-3	
A9	IN4	White-1		B9	OUT8	White-3	
A10	IN5	Black-1		B10	OUT9	Black-3	
A11	IN6	Brown-2		B11	OUT10	Brown-4	
A12	IN7	Red-2		B12	OUT11	Red-4	
A13	IN8	Orange-2		B13	OUT12	Orange-4	
A14	IN9	Yellow-2		B14	OUT13	Yellow-4	
A15	IN10	Green-2		B15	OUT14	Green-4	
A16	IN11	Blue-2		B16	OUT15	Blue-4	
A17	IN12	Purple-2		B17	—	Purple-4	
A18	IN13	Gray-2		B18	—	Gray-4	
A19	IN14	White-2		B19	0V	White-4	
A20	IN15	Black-2		B20	0V	Black-4	

**IAI America, Inc.**

Headquarters: 2690 W. 237th Street, Torrance, CA 90505 (800) 736-1712

Chicago Office: 110 E. State Pkwy, Schaumburg, IL 60173 (800) 944-0333

Atlanta Office: 1220 Kennestone Circle, Suite 108, Marietta, GA 30066 (888) 354-9470

[www.intelligentactuator.com](http://www.intelligentactuator.com)

The information contained in this product brochure may change without prior notice due to product improvements.

**IAI Industrieroboter GmbH**

Ober der Röth 4, D-65824 Schwalbach am Taunus, Germany

**IAI Robot (Thailand), CO., Ltd.**

825 PhairojKijja Tower 12th Floor, Bangna-Trad RD, Bangna, Bangkok 10260, Thailand