

ICSA2-BA□H Cartesian Robot: X-Y 2-Axes Configuration, XYB (Y-Axis Base Mount) Type

ICSPA2-BA□H Cartesian Robot: X-Y 2-Axes Configuration, XYB (Y-Axis Base Mount) Type **High-Precision Specification**

Type XYB type Stroke X-axis: 100~600mm Y-axis: 100~400mm Load capacity 5.2kg ~ 3.1kg

Model specification items Series Type Encoder type X-axis stroke + options Y-axis stroke + options Applicable controller Cable length Cable management
 ICSA2 - BA1H - A - 60AQLNM - 40AQL - T1 - 5L - SC

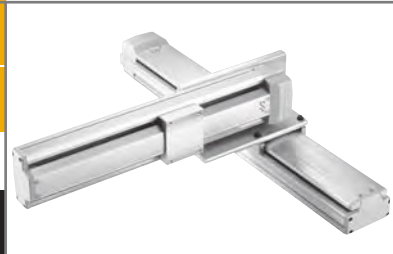

* Refer to page 61 for the details of model specification items.

Models/Specifications

Model	Axis configuration		Encoder type	Motor output (W)	Lead (mm)	Stroke (mm) In increments of 100mm	Speed (mm/s)	Load capacity (Note 1)	Positioning repeatability (mm) (Note 2)
ICSA2 [ICSPA2] -BA□H-A-***-***-T1-△-○	X-axis	ISA [ISPA] -SXM-A-60-16-***-T1	Absolute	60	16	100 ~ 600	1 ~ 800	5.2 ~ 3.1	0.02 [0.01]
	Y-axis	ISA [ISPA] -SYM-A-60-16-***-T1				100 ~ 400			
ICSA2 [ICSPA2] -BA□H-I-***-***-T1-△-○	X-axis	ISA [ISPA] -SXM-I-60-16-***-T1	Incremental	60	16	100 ~ 600	1 ~ 800	5.2 ~ 3.1	0.02 [0.01]
	Y-axis	ISA [ISPA] -SYM-I-60-16-***-T1				100 ~ 400			

* In the above model names, □ indicates the configuration direction, *** the stroke/applicable options (stroke is specified in centimeters), △ the cable length and ○ the wiring.

Options

Name	Code	Page	Remarks
AQ seal	AQ	P13	
Brake	B	P13	
Creep sensor	C	P13	
Home limit switch	L	P14	
Reverse homing specification	NM	P14	
Guide with ball-retaining mechanism	RT	P14	

Common Specifications

Drive system (Note 3)	Ball screw, rolled C10 [equivalent to rolled C5]
Backlash (Note 4)	0.05mm or less [0.02mm or less]
Guide	Integrated with base
Base	Material: Aluminum with white alumite treatment
Cable length (Note 5)	3L: 3m, 5L: 5m, □L : Length specification
Cable management	SC: Self-standing cable CT: Cable track

Load Capacity by Acceleration (kg)

Acceleration (G)	Y-axis stroke (mm)			
	100	200	300	400
0.3	5.2	4.5	3.8	3.1
0.4	2.2	1.5	0.8	0.1
0.5	0.2			
0.6				
0.7				
0.8				
0.9				
1.0				

Maximum Speed by Stroke (mm/sec)

Axis	Stroke (mm)	
	100 ~ 400	500 ~ 600
X-axis	800	
Y-axis	800	-

Applicable Controller Specifications

Applicable controller	Controller type	Model	Page
X-SEL	General-purpose type	XSEL-K-2-60□-60□-□-□□□-□-□	
	Compact type	XSEL-J-2-60□-60□-□-□□□-□-□	

Configuration direction



Caution
 (Note 1) The load capacity assumes operation at the rated acceleration (0.3 G). The actuator can be operated at accelerations beyond the rated acceleration, but the load capacity will decrease (refer to the table of load capacity by acceleration).
 (Notes 2, 3, 4) The figures in brackets apply to the ICSPA2.
 (Note 5) The cable length measures from the X-axis connector box to the controller. The standard lengths are 3 m and 5 m, but other lengths can also be specified in meters up to 20 m (e.g., 10L = 10 m).

* Refer to page 59 for other points to note.

Self-standing Cable Specification (Cable Management Code: SC)

Dimensions

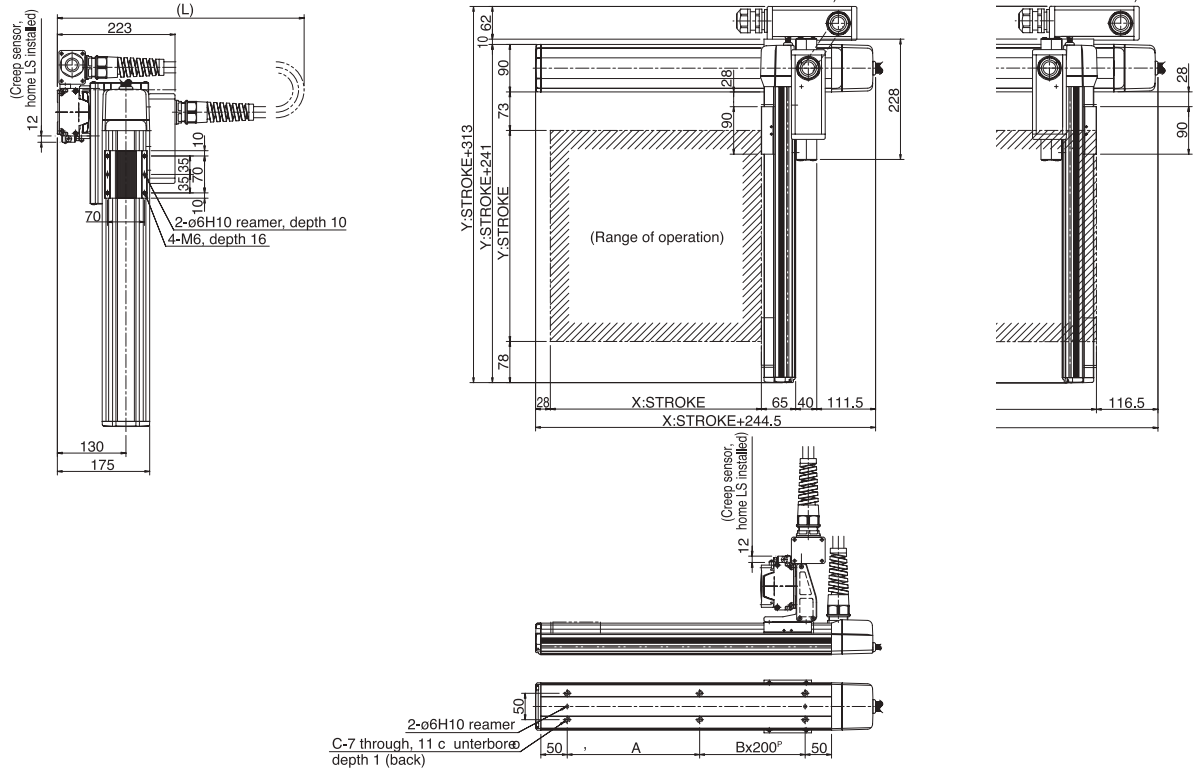

X stroke	100	200	300	400	500	600
L	(500)	(550)	(600)	(650)	(700)	(750)
A	151	251	151	251	151	251
B	0	0	1	1	2	2
C	4	4	6	6	8	8

Cable Track Specification (Cable Management Code: CT)

Dimensions

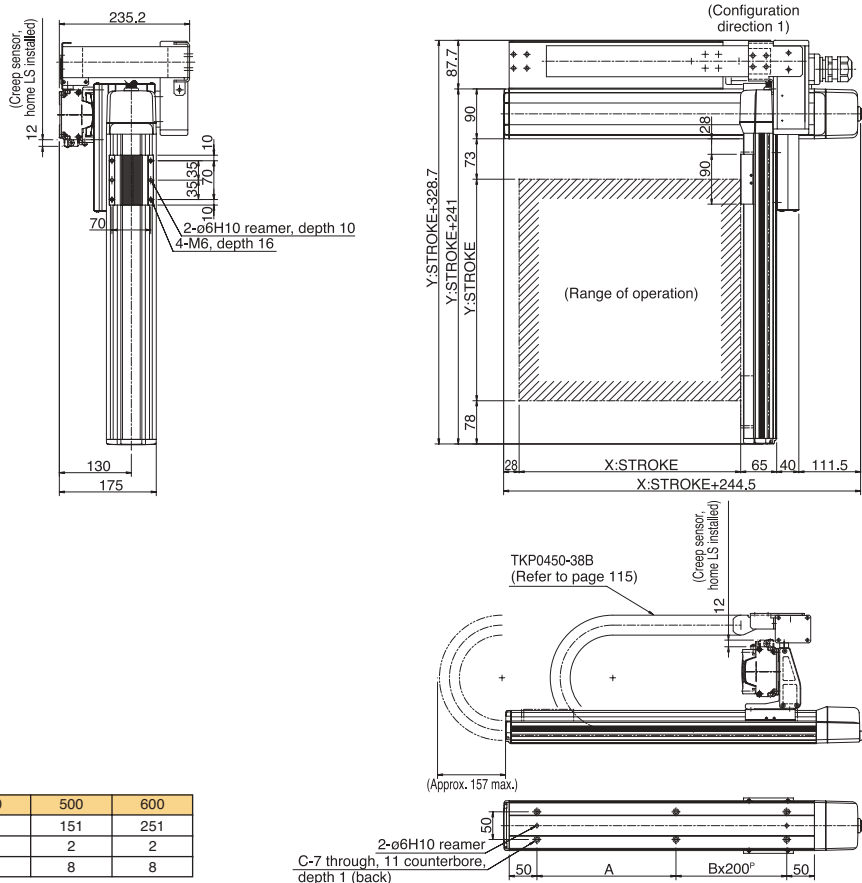

X stroke	100	200	300	400	500	600
A	151	251	151	251	151	251
B	0	0	1	1	2	2
C	4	4	6	6	8	8

ICSA2-BA□M Cartesian Robot: X-Y 2-Axes Configuration, XYB (Y-Axis Base Mount) Type

ICSPA2-BA□M Cartesian Robot: X-Y 2-Axes Configuration, XYB (Y-Axis Base Mount) Type **High-Precision Specification**

Type **XYB type** Stroke X-axis: 100~600mm Y-axis: 100~400mm Load capacity **18.2kg ~ 8.1kg**

Model specification items Series **ICSA2** - Type **BA1M** - Encoder type **A** - X-axis stroke + options **60AQLNM** - Y-axis stroke + options **40AQL** - Applicable controller **T1** - Cable length **5L** - Cable management **SC**

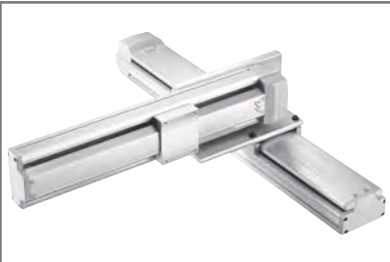

* Refer to page 61 for the details of model specification items.

Models/Specifications

Model	Axis configuration		Encoder type	Motor output (W)	Lead (mm)	Stroke (mm) In increments of 100mm	Speed (mm/s)	Load capacity (Note 1)	Positioning repeatability (mm) (Note 2)
ICSA2 [ICSPA2] -BA□M-A-***-***-T1-△-○	X-axis	ISA [ISPA] -SXM-A-60-8-***-T1	Absolute	60	8	100 ~ 600	1 ~ 400	18.2 ~ 8.1	0.02 [0.01]
	Y-axis	ISA [ISPA] -SYM-A-60-8-***-T1				100 ~ 400			
ICSA2 [ICSPA2] -BA□M-I-***-***-T1-△-○	X-axis	ISA [ISPA] -SXM-I-60-8-***-T1	Incremental	60	8	100 ~ 600	1 ~ 400	18.2 ~ 8.1	0.02 [0.01]
	Y-axis	ISA [ISPA] -SYM-I-60-8-***-T1				100 ~ 400			

* In the above model names, □ indicates the configuration direction, *** the stroke/applicable options (stroke is specified in centimeters), △ the cable length and ○ the wiring.

Options

Name	Code	Page	Remarks
AQ seal	AQ	P13	
Brake	B	P13	
Creep sensor	C	P13	
Home limit switch	L	P14	
Reverse homing specification	NM	P14	
Guide with ball-retaining mechanism	RT	P14	

Common Specifications

Drive system (Note 3)	Ball screw, rolled C10 [equivalent to rolled C5]
Backlash (Note 4)	0.05mm or less [0.02mm or less]
Guide	Integrated with base
Base	Material: Aluminum with white alumite treatment
Cable length (Note 5)	3L: 3m, 5L: 5m, □L : Length specification
Cable management	SC: Self-standing cable CT: Cable track

Load Capacity by Acceleration (kg)

Acceleration (G)	Y-axis stroke (mm)			
	100	200	300	400
0.3	18.2	16.6	12.1	8.1
0.4	11.7	11	10.3	8.1
0.5	8.2	7.5	6.8	6.1
0.6	5.2	4.5	3.8	3.1
0.7				
0.8				
0.9				
1.0				

Maximum Speed by Stroke (mm/sec)

Axis	Stroke (mm)	
	100 ~ 400	500 ~ 600
X-axis	400	
Y-axis	400	-

Configuration direction

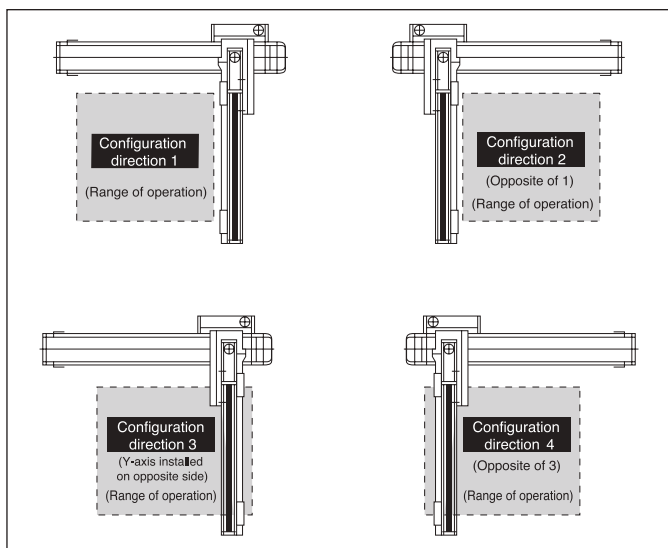

Applicable Controller Specifications

Applicable controller	Controller type	Model	Page
X-SEL	General-purpose type	XSEL-K-2-60□-60□-□-□□□-□-□	
	Compact type	XSEL-J-2-60□-60□-□-□□□-□-□	

Caution
 (Note 1) The load capacity assumes operation at the rated acceleration (0.3 G). The actuator can be operated at accelerations beyond the rated acceleration, but the load capacity will decrease (refer to the table of load capacity by acceleration).
 (Notes 2, 3, 4) The figures in brackets apply to the ICSPA2.
 (Note 5) The cable length measures from the X-axis connector box to the controller. The standard lengths are 3 m and 5 m, but other lengths can also be specified in meters up to 20 m (e.g., 10L = 10 m).

Self-standing Cable Specification (Cable Management Code: SC)

Dimensions

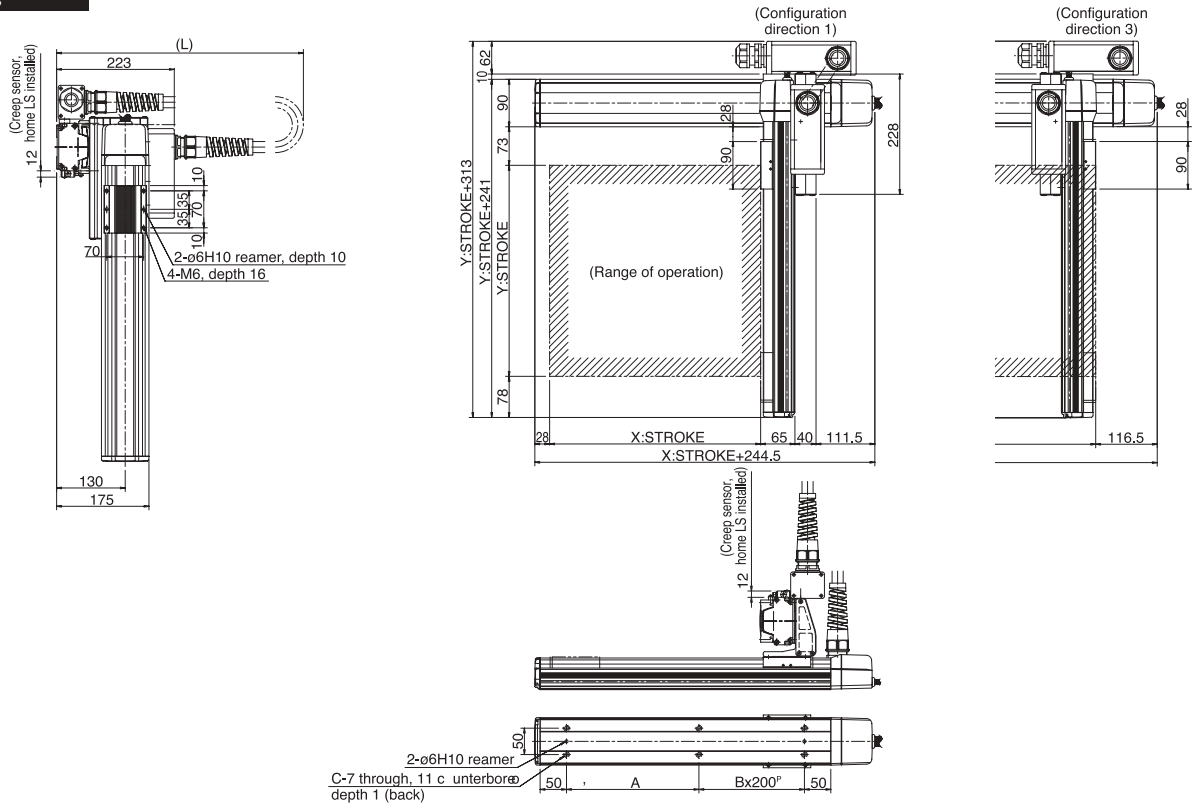

X stroke	100	200	300	400	500	600
L	(500)	(550)	(600)	(650)	(700)	(750)
A	151	251	151	251	151	251
B	0	0	1	1	2	2
C	4	4	6	6	8	8

Cable Track Specification (Cable Management Code: CT)

Dimensions

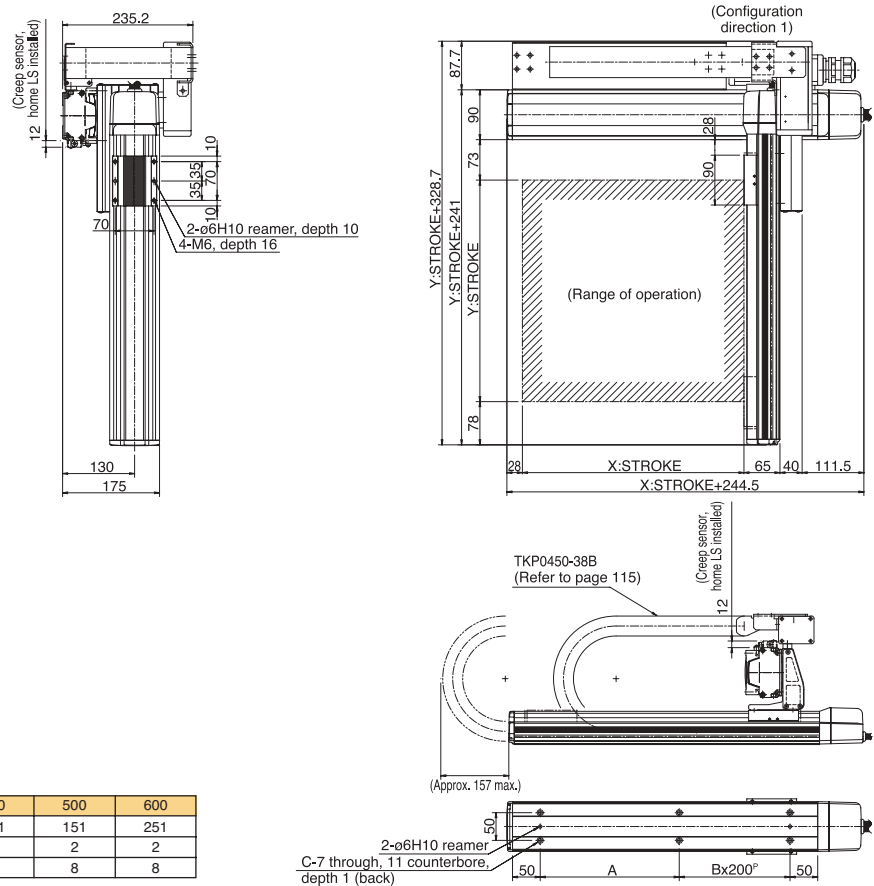

X stroke	100	200	300	400	500	600
A	151	251	151	251	151	251
B	0	0	1	1	2	2
C	4	4	6	6	8	8

ICSA2-BB□H

Cartesian Robot: X-Y 2-Axes Configuration, XYB (Y-Axis Base Mount) Type

ICSPA2-BB□H

Cartesian Robot: X-Y 2-Axes Configuration, XYB (Y-Axis Base Mount) Type **High-Precision Specification**

Type XYB type

Stroke X-axis: 200~800mm Y-axis: 100~400mm

Load capacity 12kg ~ 11.1kg

Model specification items: ICSA2 - BB1H - A - 80AQLNM - 40AQL - T1 - 5L - SC

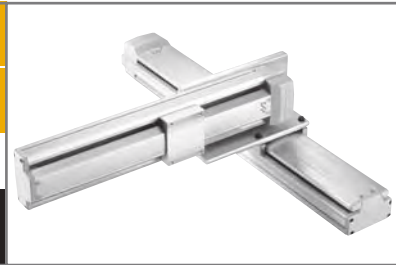

* Refer to page 61 for the details of model specification items.

Models/Specifications

Model	Axis configuration		Encoder type	Motor output (W)	Lead (mm)	Stroke (mm) In increments of 100mm	Speed (mm/s) (Note 1)	Load capacity (Note 2)	Positioning repeatability (mm) (Note 3)
ICSA2 [ICSPA2] -BB□H-A-***-***-T1-△-○	X-axis	ISA [ISPA] -MXM-A-100-20-***-T1	Absolute	100	20	200 ~ 800	1 ~ 1000	12 ~ 11.1	0.02 [0.01]
	Y-axis	ISA [ISPA] -SXM-A-60-16-***-T1		60	16	100 ~ 400	1 ~ 800		
ICSA2 [ICSPA2] -BB□H-I-***-***-T1-△-○	X-axis	ISA [ISPA] -MXM-I-100-20-***-T1	Incremental	100	20	200 ~ 800	1 ~ 1000		
	Y-axis	ISA [ISPA] -SXM-I-60-16-***-T1		60	16	100 ~ 400	1 ~ 800		

* In the above model names, □ indicates the configuration direction, *** the stroke/applicable options (stroke is specified in centimeters), △ the cable length and ○ the wiring.

Options

Name	Code	Page	Remarks
AQ seal	AQ	P13	
Brake	B	P13	
Creep sensor	C	P13	
Home limit switch	L	P14	
Reverse homing specification	NM	P14	
Guide with ball-retaining mechanism	RT	P14	

Common Specifications

Drive system (Note 4)	Ball screw, rolled C10 [equivalent to rolled C5]
Backlash (Note 5)	0.05mm or less [0.02mm or less]
Guide	Integrated with base
Base	Material: Aluminum with white alumite treatment
Cable length (Note 6)	3L: 3m, 5L: 5m, □L : Length specification
Cable management	SC: Self-standing cable CT: Cable track

Load Capacity by Acceleration (kg)

Acceleration (G)	Y-axis stroke (mm)			
	100	200	300	400
0.3	12.0	12.0	11.8	11.1
0.4	8.2	7.5	6.8	6.1
0.5	5.2	4.5	3.8	3.1
0.6	3.2	2.5	1.8	1.1
0.7	1.7	1.0	0.3	
0.8	0.7			
0.9				
1.0				

Maximum Speed by Stroke (mm/sec)

Axis	Stroke (mm)			
	100	200 ~ 400	500 ~ 700	800
X-axis	-	1000	795	
Y-axis	800	-	-	

Applicable Controller Specifications

Applicable controller	Controller type	Model	Page
X-SEL	General-purpose type	XSEL-K-2-100□-60□-□-□□□-□-□	
	Compact type	XSEL-J-2-100□-60□-□-□□□-□-□	

Configuration direction

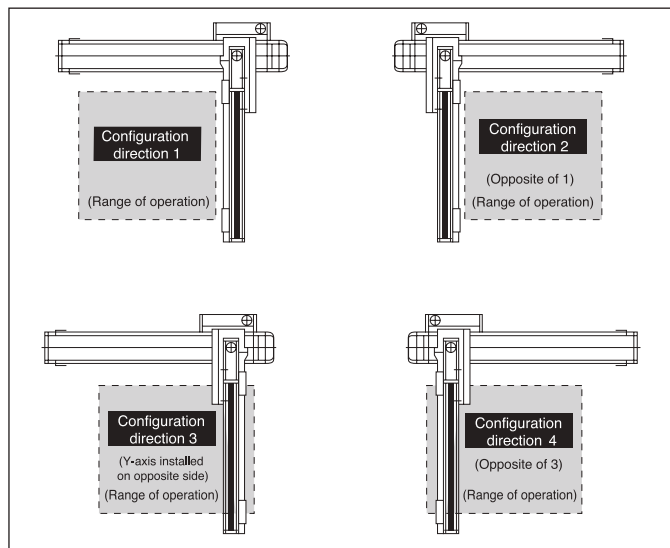

(Note 1) The maximum speed will vary depending on the stroke. (Refer to the table of maximum speed by stroke.)
 (Note 2) The load capacity assumes operation at the rated acceleration (0.3 G). The actuator can be operated at accelerations beyond the rated acceleration, but the load capacity will decrease (refer to the table of load capacity by acceleration).
 (Notes 3, 4, 5) The figures in brackets apply to the ICSPA2.
 (Note 6) The cable length measures from the X-axis connector box to the controller. The standard lengths are 3 m and 5 m, but other lengths can also be specified in meters up to 20 m (e.g., 10L = 10 m).

* Refer to page 59 for other points to note.

Self-standing Cable Specification (Cable Management Code: SC)

Dimensions

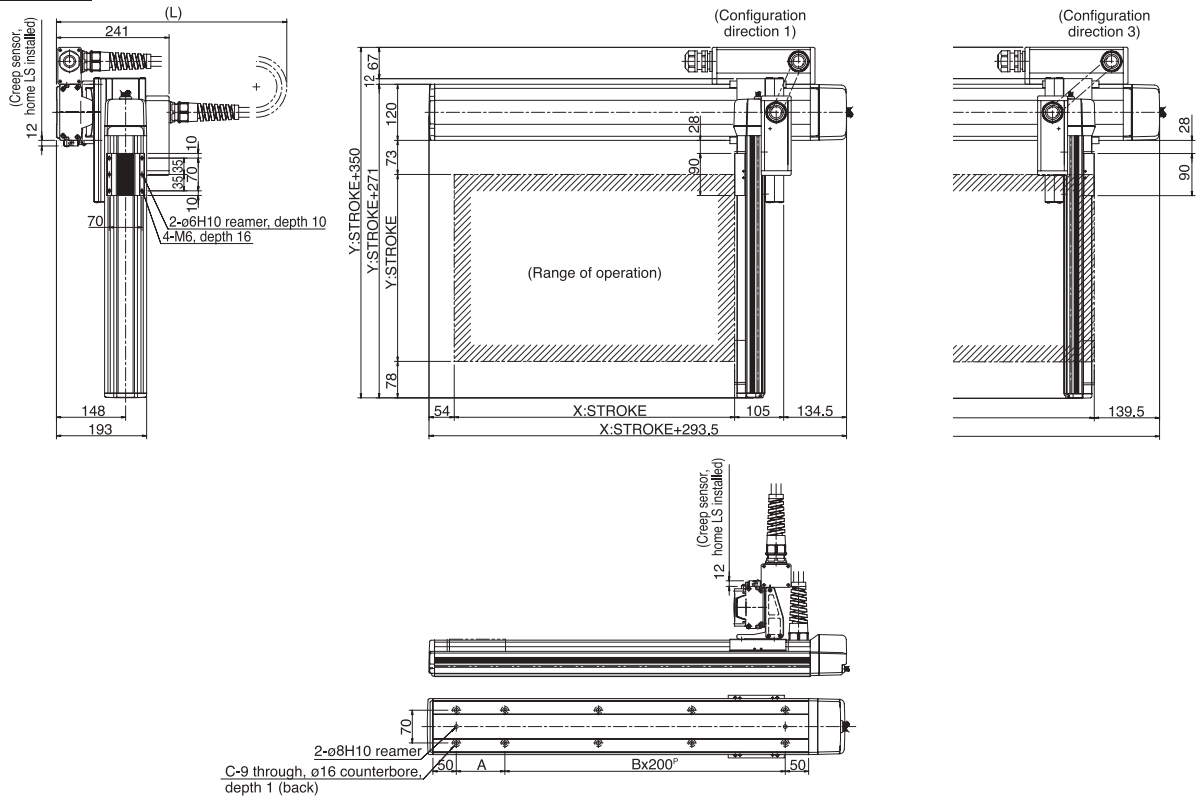

X stroke	200	300	400	500	600	700	800
L	(550)	(600)	(650)	(700)	(750)	(800)	(850)
A	104	204	104	204	104	204	104
B	1	1	2	2	3	3	4
C	6	6	8	8	10	10	12

Cable Track Specification (Cable Management Code: CT)

Dimensions

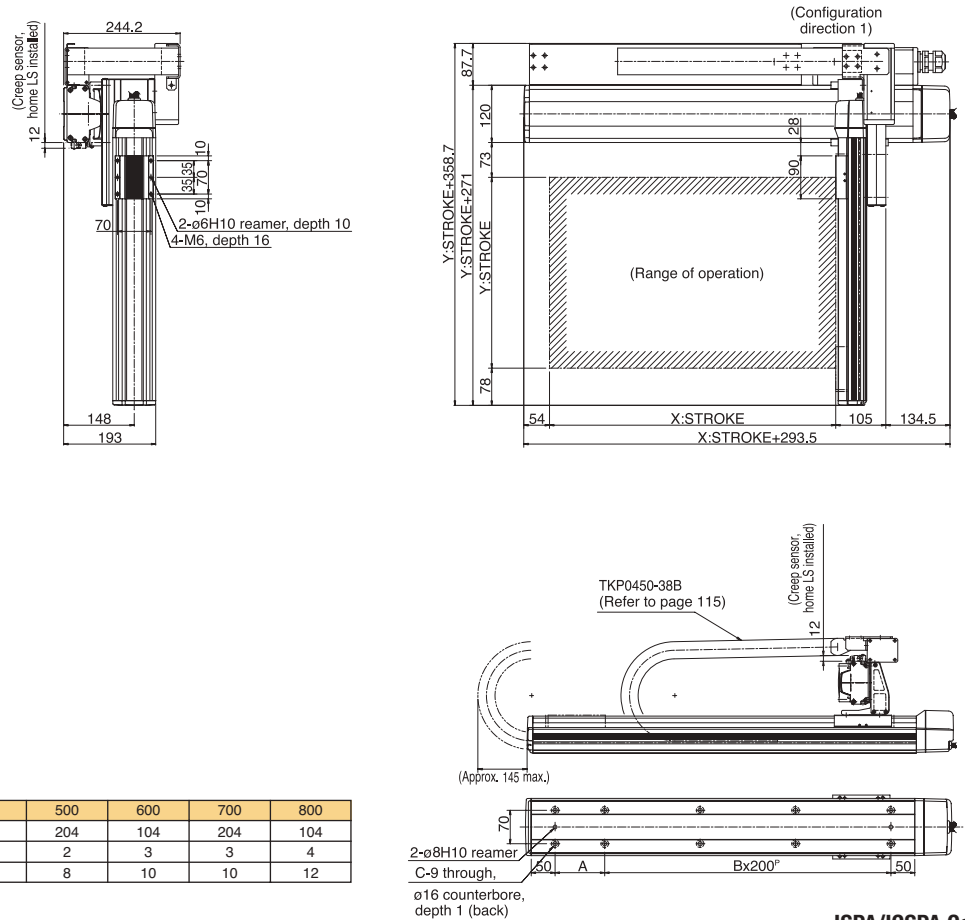

X stroke	200	300	400	500	600	700	800
A	104	204	104	204	104	204	104
B	1	1	2	2	3	3	4
C	6	6	8	8	10	10	12

Single-Axis Robots
Cartesian Robots

ICSA2-BB **M** Cartesian Robot: X-Y 2-Axes Configuration, XYB (Y-Axis Base Mount) Type
ICSPA2-BB **M** Cartesian Robot: X-Y 2-Axes Configuration, XYB (Y-Axis Base Mount) Type **High-Precision Specification**

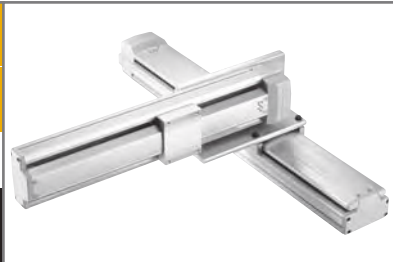

Type	XYB type	Stroke	X-axis: 200~800mm Y-axis: 100~400mm	Load capacity	25kg ~ 21.8kg			
Model specification items	Series	Type	Encoder type	X-axis stroke + options	Y-axis stroke + options	Applicable controller	Cable length	Cable management
	ICSA2 - BB1M	- A	-	80AQLNM	- 40AQL	- T1	- 5L	- SC

* Refer to page 61 for the details of model specification items.

Models/Specifications

Model	Axis configuration		Encoder type	Motor output (W)	Lead (mm)	Stroke (mm) In increments of 100mm	Speed (mm/s) (Note 1)	Load capacity (Note 2)	Positioning repeatability (mm) (Note 3)
ICSA2 [ICSPA2] -BB□M-A-***-***-T1-△-○	X-axis	ISA [ISPA] -MXM-A-100-10-***-T1	Absolute	100	10	200 ~ 800	1 ~ 500	25 ~ 21.8	0.02 [0.01]
	Y-axis	ISA [ISPA] -SYM-A-60-8-***-T1		60	8	100 ~ 400	1 ~ 400		
ICSA2 [ICSPA2] -BB□M-I-***-***-T1-△-○	X-axis	ISA [ISPA] -MXM-I-100-10-***-T1	Incremental	100	10	200 ~ 800	1 ~ 500		
	Y-axis	ISA [ISPA] -SYM-I-60-8-***-T1		60	8	100 ~ 400	1 ~ 400		

* In the above model names, □ indicates the configuration direction, *** the stroke/applicable options (stroke is specified in centimeters), △ the cable length and ○ the wiring.

Options

Name	Code	Page	Remarks
AQ seal	AQ	P13	
Brake	B	P13	
Creep sensor	C	P13	
Home limit switch	L	P14	
Reverse homing specification	NM	P14	
Guide with ball-retaining mechanism	RT	P14	

Common Specifications

Drive system (Note 4)	Ball screw, rolled C10 [equivalent to rolled C5]
Backlash (Note 5)	0.05mm or less [0.02mm or less]
Guide	Integrated with base
Base	Material: Aluminum with white alumite treatment
Cable length (Note 6)	3L: 3m, 5L: 5m, □L : Length specification
Cable management	SC: Self-standing cable CT: Cable track

Load Capacity by Acceleration (kg)

Acceleration (G)	Y-axis stroke (mm)			
	100	200	300	400
0.3	25.0	25.0	25.0	21.8
0.4	18.5	18.5	18.5	18.5
0.5	15.0	15.0	15.0	15.0
0.6	12.0	12.0	11.8	11.1
0.7				
0.8				
0.9				
1.0				

Maximum Speed by Stroke (mm/sec)

Axis	Stroke (mm)				
	100	200 ~ 400	500 ~ 600	700	800
X-axis	-	500	480	380	
Y-axis	400	-	-	-	

Applicable Controller Specifications

Applicable controller	Controller type	Model	Page
X-SEL	General-purpose type	XSEL-K-2-100□-60□-□-□□□-□	
	Compact type	XSEL-J-2-100□-60□-□-□□□-□	

Configuration direction

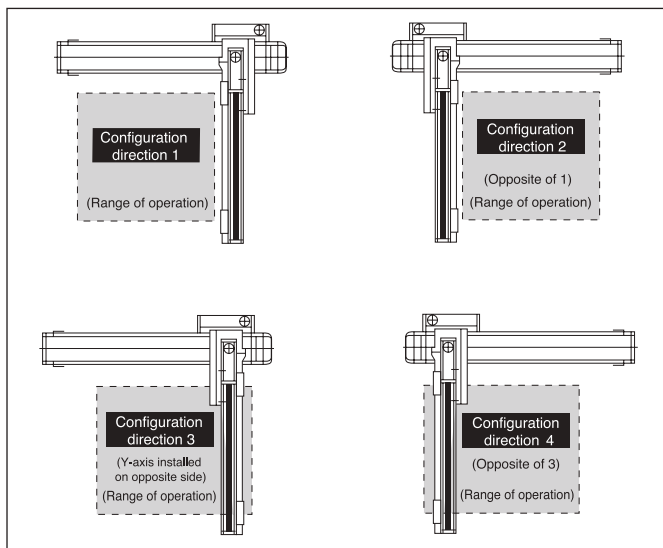

Caution

(Note 1) The maximum speed will vary depending on the stroke. (Refer to the table of maximum speed by stroke.)
 (Note 2) The load capacity assumes operation at the rated acceleration (0.3 G). The actuator can be operated at accelerations beyond the rated acceleration, but the load capacity will decrease (refer to the table of load capacity by acceleration).
 (Notes 3, 4, 5) The figures in brackets apply to the ICSPA2.
 (Note 6) The cable length measures from the X-axis connector box to the controller. The standard lengths are 3 m and 5 m, but other lengths can also be specified in meters up to 20 m (e.g., 10L = 10 m).

* Refer to page 59 for other points to note.

Self-standing Cable Specification (Cable Management Code: SC)

Dimensions

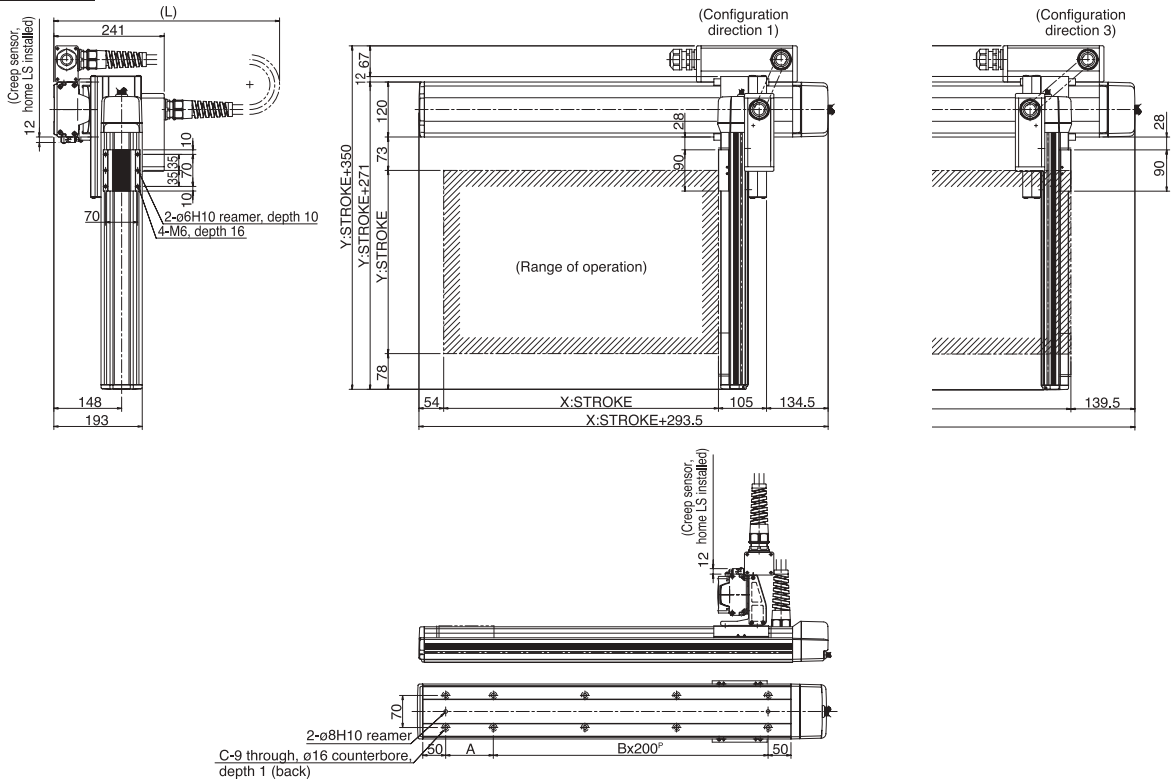

X stroke	200	300	400	500	600	700	800
L	(550)	(600)	(650)	(700)	(750)	(800)	(850)
A	104	204	104	204	104	204	104
B	1	1	2	2	3	3	4
C	6	6	8	8	10	10	12

Cable Track Specification (Cable Management Code: CT)

Dimensions

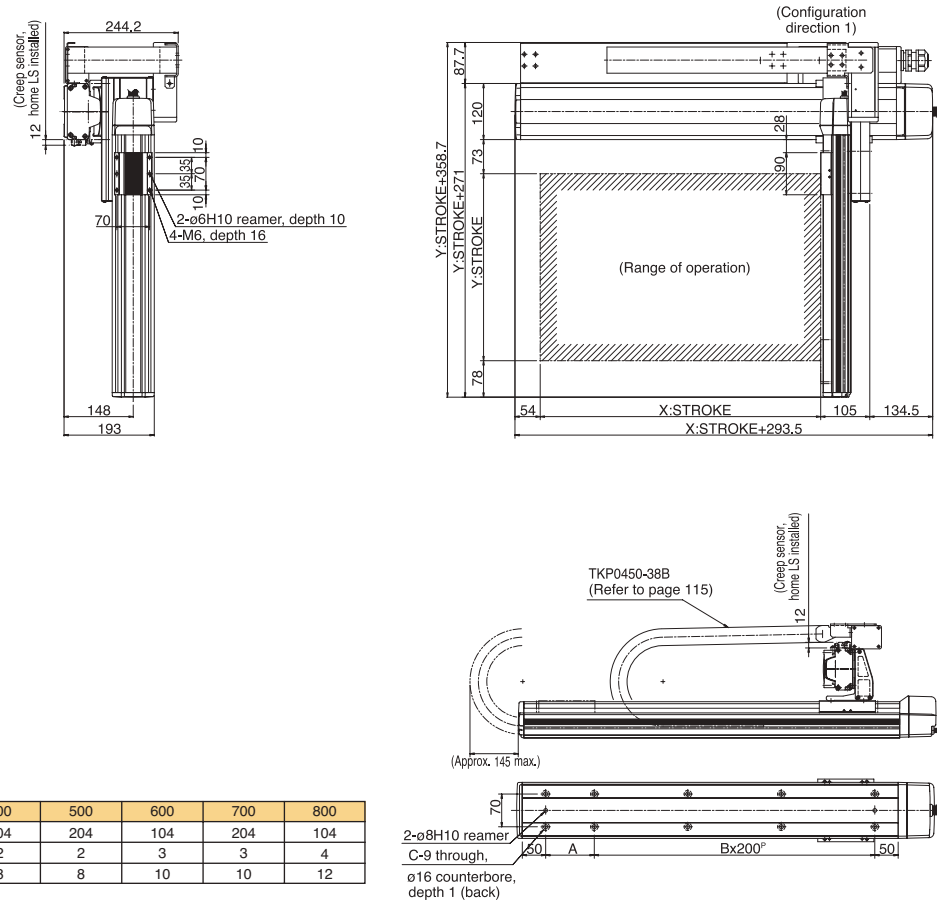

X stroke	200	300	400	500	600	700	800
A	104	204	104	204	104	204	104
B	1	1	2	2	3	3	4
C	6	6	8	8	10	10	12

Single-Axis Robots
Cartesian Robots

ICSA2-BC□H Cartesian Robot: X-Y 2-Axes Configuration, XYB (Y-Axis Base Mount) Type
ICSPA2-BC□H Cartesian Robot: X-Y 2-Axes Configuration, XYB (Y-Axis Base Mount) Type **High-Precision Specification**

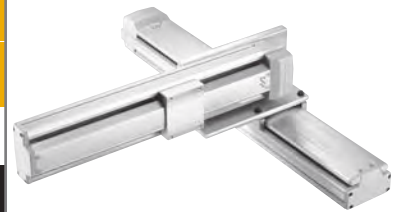

Type XYB type Stroke X-axis: 200~800mm Y-axis: 100~500mm Load capacity 20kg ~ 18.7kg

Model specification items Series Type Encoder type X-axis stroke + options Y-axis stroke + options Applicable controller Cable length Cable management
 ICSA2 - BC1H - A - 80AQLNM - 50AQL - T1 - 5L - SC

* Refer to page 61 for the details of model specification items.

Models/Specifications

Model	Axis configuration		Encoder type	Motor output (W)	Lead (mm)	Stroke (mm) In increments of 100mm	Speed (mm/s) (Note 1)	Load capacity (Note 2)	Positioning repeatability (mm) (Note 3)
ICSA2 [ICSPA2] -BC□H-A-***-***-T1-△-○	X-axis	ISA [ISPA] -MXM-A-200-20-***-T1	Absolute	200	20	200 ~ 800	1 ~ 1000	20 ~ 18.7	±0.02 [±0.01]
	Y-axis	ISA [ISPA] -MYM-A-100-20-***-T1		100		100 ~ 500			
ICSA2 [ICSPA2] -BC□H-I-***-***-T1-△-○	X-axis	ISA [ISPA] -MXM-I-200-20-***-T1	Incremental	200		200 ~ 800			
	Y-axis	ISA [ISPA] -MYM-I-100-20-***-T1		100		100 ~ 500			

* In the above model names, □ indicates the configuration direction, *** the stroke/applicable options (stroke is specified in centimeters), △ the cable length and ○ the wiring.

Options

Name	Code	Page	Remarks
AQ seal	AQ	P13	
Brake	B	P13	
Creep sensor	C	P13	
Home limit switch	L	P14	
Reverse homing specification	NM	P14	
Guide with ball-retaining mechanism	RT	P14	

Common Specifications

Drive system (Note 4)	Ball screw, rolled C10 [equivalent to rolled C5]
Backlash (Note 5)	0.05mm or less [0.02mm or less]
Guide	Integrated with base
Base	Material: Aluminum with white alumite treatment
Cable length (Note 6)	3L: 3m, 5L: 5m, □L : Length specification
Cable management	SC: Self-standing cable CT: Cable track

Load Capacity by Acceleration (kg)

Y-axis stroke (mm) / Acceleration (G)	100	200	300	400	500
0.3	20.0	20.0	20.0	20.0	18.7
0.4	15.0	15.0	15.0	15.0	14.8
0.5	12.0	11.8	10.8	9.8	8.8
0.6	8.8	7.8	6.8	5.8	4.8
0.7	5.8	4.8	3.8	2.8	1.8
0.8	3.8	2.8	1.8	0.8	
0.9	2.3	1.3	0.3		
1.0	0.8				

Maximum Speed by Stroke (mm/sec)

Stroke (mm) / Axis	100	200 ~ 500	600 ~ 700	800
X-axis	-	1000		795
Y-axis	1000		-	-

Configuration direction

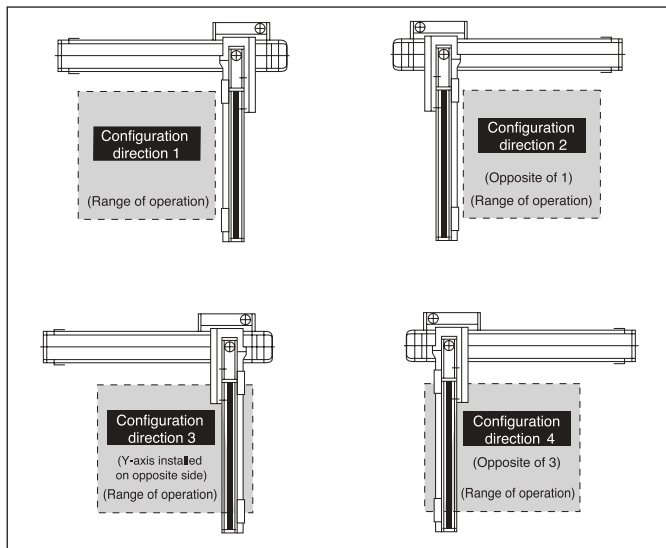

Applicable Controller Specifications

Applicable controller	Controller type	Model	Page
X-SEL	General-purpose type	XSEL-K-2-200□-100□-□-□□□-□-□	
	Compact type	XSEL-J-2-200□-100□-□-□□□-□-□	

Caution

(Note 1) The maximum speed will vary depending on the stroke. (Refer to the table of maximum speed by stroke.)
 (Note 2) The load capacity assumes operation at the rated acceleration (0.3 G). The actuator can be operated at accelerations beyond the rated acceleration, but the load capacity will decrease (refer to the table of load capacity by acceleration).
 (Notes 3, 4, 5) The figures in brackets apply to the ICSPA2.
 (Note 6) The cable length measures from the X-axis connector box to the controller. The standard lengths are 3 m and 5 m, but other lengths can also be specified in meters up to 20 m (e.g., 10L = 10 m).

* Refer to page 59 for other points to note.

Self-standing Cable Specification (Cable Management Code: SC)

Dimensions

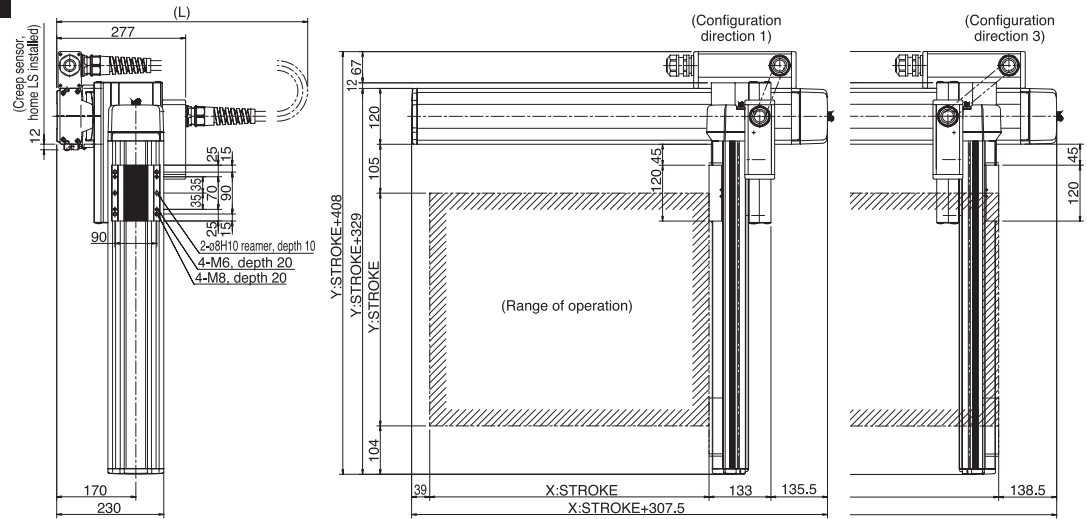

X stroke	200	300	400	500	600	700	800
L	(550)	(600)	(650)	(700)	(750)	(800)	(850)
A	104	204	104	204	104	204	104
B	1	1	2	2	3	3	4
C	6	6	8	8	10	10	12

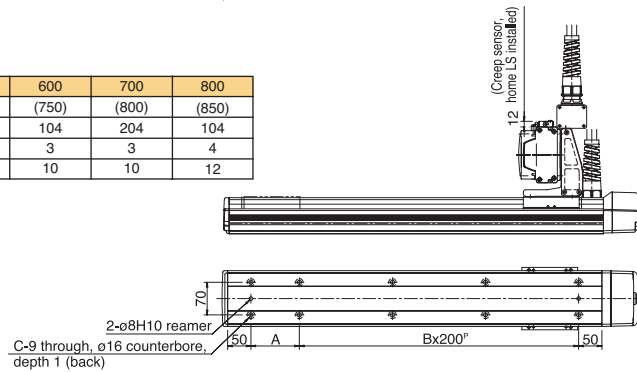

Cable Track Specification (Cable Management Code: CT)

Dimensions

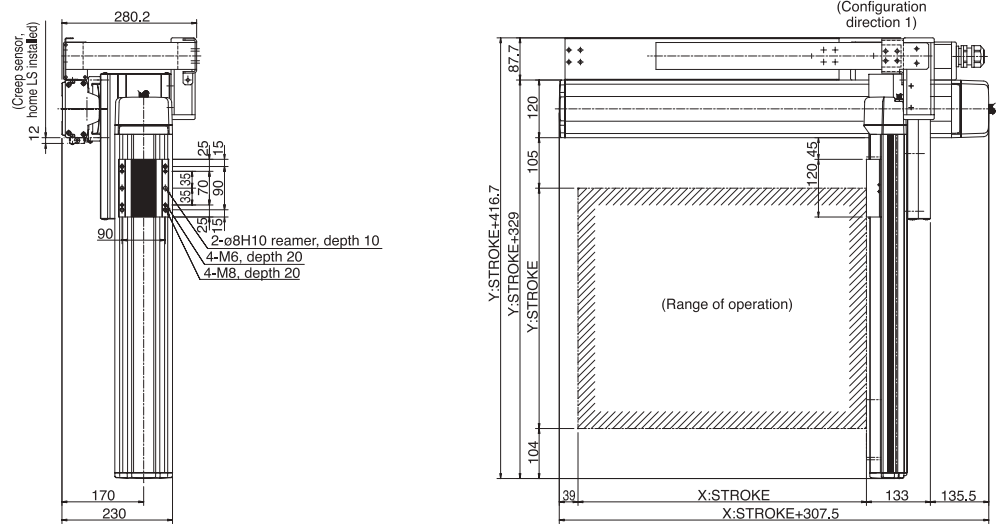

X stroke	200	300	400	500	600	700	800
A	104	204	104	204	104	204	104
B	1	1	2	2	3	3	4
C	6	6	8	8	10	10	12

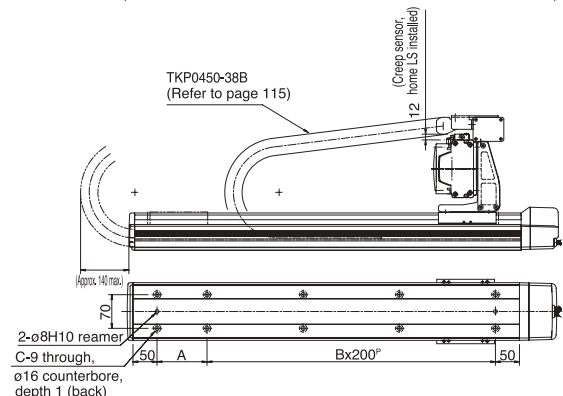

Single-Axis Robots
Cartesian Robots

ICSA2-BC□M Cartesian Robot: X-Y 2-Axes Configuration, XYB (Y-Axis Base Mount) Type

ICSPA2-BC□M Cartesian Robot: X-Y 2-Axes Configuration, XYB (Y-Axis Base Mount) Type **High-Precision Specification**

Type XYB type Stroke X-axis: 200-800mm Y-axis: 100-500mm Load capacity 28.8kg ~ 18.7kg

Model specification items Series Type Encoder type X-axis stroke + options Y-axis stroke + options Applicable controller Cable length Cable management
 ICSA2 - BC1M - A - 80AQLNM - 50AQL - T1 - 5L - SC

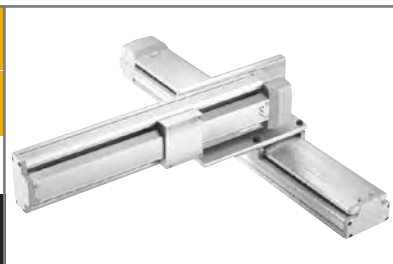

* Refer to page 61 for the details of model specification items.

Models/Specifications

Model	Axis configuration		Encoder type	Motor output (W)	Lead (mm)	Stroke (mm) In increments of 100mm	Speed (mm/s) (Note 1)	Load capacity (Note 2)	Positioning repeatability (mm) (Note 3)
ICSA2 [ICSPA2] -BC□M-A-***-***-T1-△-○	X-axis	ISA [ISPA] -MXM-A-100-10-***-T1	Absolute	100	10	200 ~ 800	1 ~ 500	28.8 ~ 18.7	0.02 [0.01]
	Y-axis	ISA [ISPA] -MYM-A-100-10-***-T1				100 ~ 500			
ICSA2 [ICSPA2] -BC□M-I-***-***-T1-△-○	X-axis	ISA [ISPA] -MXM-I-100-10-***-T1	Incremental			200 ~ 800			
	Y-axis	ISA [ISPA] -MYM-I-100-10-***-T1				100 ~ 500			

* In the above model names, □ indicates the configuration direction, *** the stroke/applicable options (stroke is specified in centimeters), △ the cable length and ○ the wiring.

Options

Name	Code	Page	Remarks
AQ seal	AQ	P13	
Brake	B	P13	
Creep sensor	C	P13	
Home limit switch	L	P14	
Reverse homing specification	NM	P14	
Guide with ball-retaining mechanism	RT	P14	

Common Specifications

Drive system (Note 4)	Ball screw, rolled C10 [equivalent to rolled C5]
Backlash (Note 5)	0.05mm or less [0.02mm or less]
Guide	Integrated with base
Base	Material: Aluminum with white alumite treatment
Cable length (Note 6)	3L: 3m, 5L: 5m, □L : Length specification
Cable management	SC: Self-standing cable CT: Cable track

Load Capacity by Acceleration (kg)

Y-axis stroke (mm)	100	200	300	400	500
Acceleration (G)					
0.3	28.8	27.8	26.8	21.8	18.7
0.4	18.8	17.8	16.8	15.8	14.8
0.5	12.8	11.8	10.8	9.8	8.8
0.6	8.8	7.8	6.8	5.8	4.8
0.7					
0.8					
0.9					
1.0					

Maximum Speed by Stroke (mm/sec)

Stroke (mm)	100	200 ~ 500	600	700	800
Axis					
X-axis	-	500		480	380
Y-axis	500		-	-	-

Configuration direction

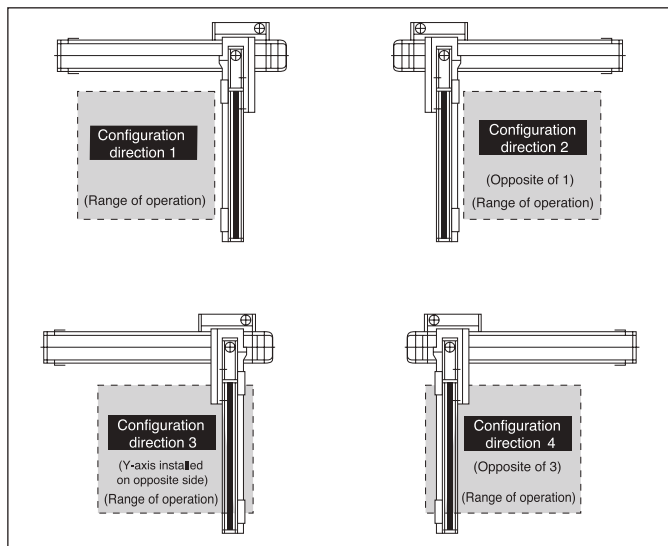

Applicable Controller Specifications

Applicable controller	Controller type	Model	Page
X-SEL	General-purpose type	XSEL-K-2-100□-100□-□-□□□-□-□	
	Compact type	XSEL-J-2-100□-100□-□-□□□□-□-□	

Caution

(Note 1) The maximum speed will vary depending on the stroke. (Refer to the table of maximum speed by stroke.)
 (Note 2) The load capacity assumes operation at the rated acceleration (0.3 G). The actuator can be operated at accelerations beyond the rated acceleration, but the load capacity will decrease (refer to the table of load capacity by acceleration).
 (Notes 3, 4, 5) The figures in brackets apply to the ICSPA2.
 (Note 6) The cable length measures from the X-axis connector box to the controller. The standard lengths are 3 m and 5 m, but other lengths can also be specified in meters up to 20 m (e.g., 10L = 10 m).

* Refer to page 59 for other points to note.

Self-standing Cable Specification (Cable Management Code: SC)

Dimensions

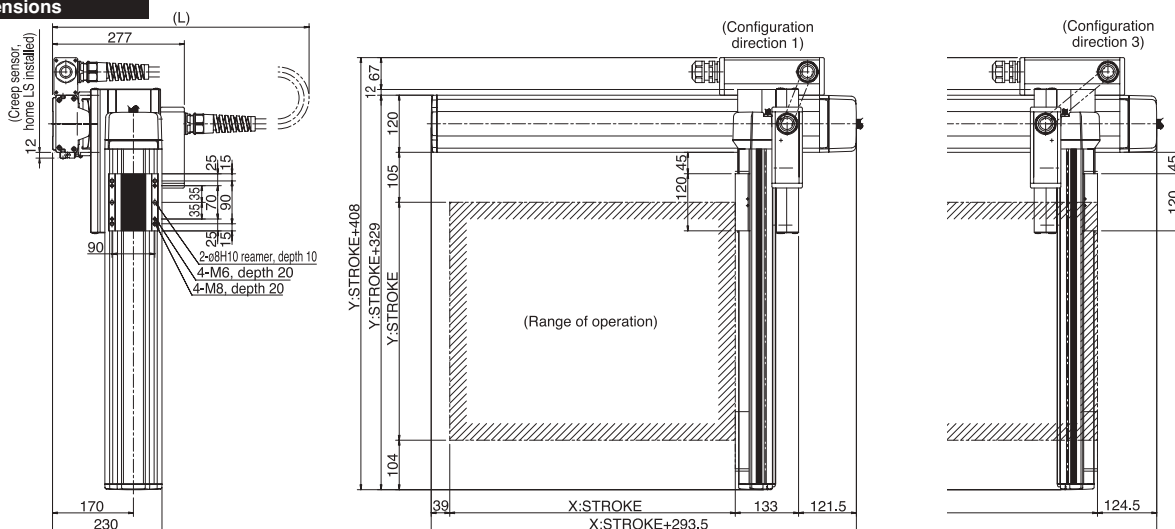

X stroke	200	300	400	500	600	700	800
L	(550)	(600)	(650)	(700)	(750)	(800)	(850)
A	104	204	104	204	104	204	104
B	1	1	2	2	3	3	4
C	6	6	8	8	10	10	12

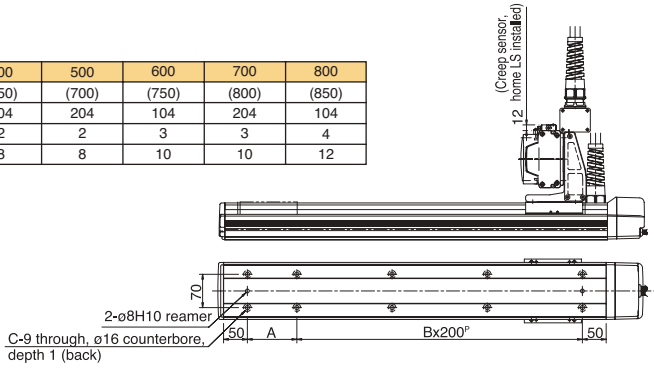

Cable Track Specification (Cable Management Code: CT)

Dimensions

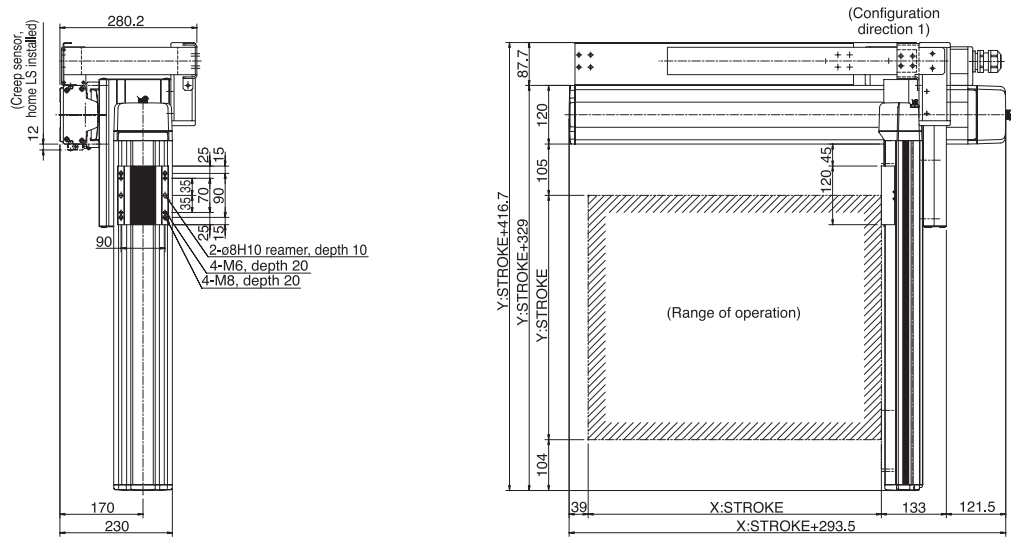

X stroke	200	300	400	500	600	700	800
A	104	204	104	204	104	204	104
B	1	1	2	2	3	3	4
C	6	6	8	8	10	10	12

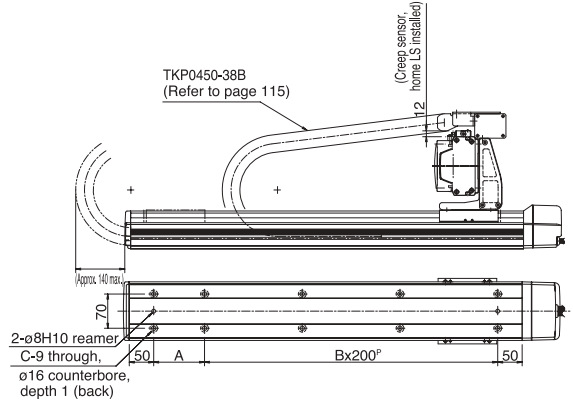

Single-Axis Robots
Cartesian Robots

ICSA2-BD□H Cartesian Robot: X-Y 2-Axes Configuration, XYB (Y-Axis Base Mount) Type

ICSPA2-BD□H Cartesian Robot: X-Y 2-Axes Configuration, XYB (Y-Axis Base Mount) Type **High-Precision Specification**

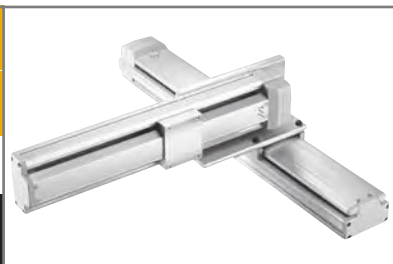

Type XYB type Stroke X-axis: 800~2000mm Y-axis: 100~500mm Load capacity 20kg ~ 18.7kg

Model specification items Series Type Encoder type X-axis stroke + options Y-axis stroke + options Applicable controller Cable length Cable management
 ICSA2 - BD1M - A - 200AQLNM - 50AQL - T1 - 5L - CT

* Refer to page 61 for the details of model specification items.

Models/Specifications

Model	Axis configuration		Encoder type	Motor output (W)	Lead (mm)	Stroke (mm) In increments of 100mm	Speed (mm/s) (Note 1)	Load capacity (Note 2)	Positioning repeatability (mm) (Note 3)
ICSA2 [ICSPA2] -BD□H-A-***-***-T1-△○	X-axis	ISA [ISPA] -MXMX-A-200-20-***-T1	Absolute	200	20	800 ~ 2000	1 ~ 1000	20 ~ 18.7	±0.02 [±0.01]
	Y-axis	ISA [ISPA] -MYM-A-100-20-***-T1		100		100 ~ 500			
ICSA2 [ICSPA2] -BD□H-I-***-***-T1-△○	X-axis	ISA [ISPA] -MXMX-I-200-20-***-T1	Incremental	200		800 ~ 2000			
	Y-axis	ISA [ISPA] -MYM-I-100-20-***-T1		100		100 ~ 500			

* In the above model names, □ indicates the configuration direction, *** the stroke/applicable options (stroke is specified in centimeters), △ the cable length and ○ the wiring.

Options

Name	Code	Page	Remarks
AQ seal	AQ	P13	
Brake	B	P13	
Creep sensor	C	P13	
Home limit switch	L	P14	
Reverse homing specification	NM	P14	
Guide with ball-retaining mechanism	RT	P14	

Common Specifications

Drive system (Note 4)	Ball screw, rolled C10 [equivalent to rolled C5]
Backlash (Note 5)	0.05mm or less [0.02mm or less]
Guide	Integrated with base
Base	Material: Aluminum with white alumite treatment
Cable length (Note 6)	3L: 3m, 5L: 5m, □L : Length specification
Cable management	CT: Cable track

Load Capacity by Acceleration (kg)

Acceleration (G)	Y-axis stroke (mm) 100	200	300	400	500
0.3	20.0	20.0	20.0	20.0	18.7
0.4					
0.5					
0.6					
0.7					
0.8					
0.9					
1.0					

Maximum Speed by Stroke (mm/sec)

Stroke (mm)	100 ~ 500	800 ~ 1300	1400	1500	1600	1700	1800	1900	2000
X-axis	-	1000	950	800	700	600	550	500	450
Y-axis	-	-	-	-	-	-	-	-	-

Applicable Controller Specifications

Applicable controller	Controller type	Model	Page
X-SEL	General-purpose type	XSEL-K-2-200□-100□-□-□□□-□-□	
	Compact type	XSEL-J-2-200□-100□-□-□□□-□-□	

Configuration direction

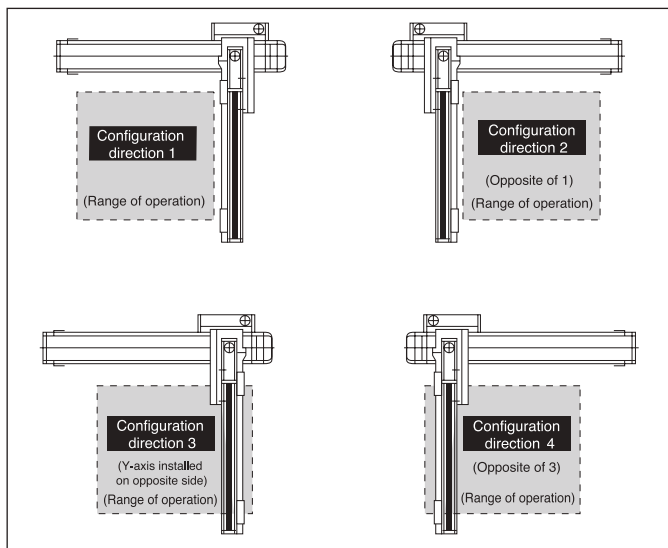

(Note 1) The maximum speed will vary depending on the stroke. (Refer to the table of maximum speed by stroke.)
 (Note 2) The load capacity assumes operation at the rated acceleration (0.3 G). The rated acceleration is the maximum specifiable acceleration for both the ICSA2 and ICSPA2.
 (Notes 3, 4, 5) The figures in brackets apply to the ICSPA2.
 (Note 6) The cable length measures from the X-axis connector box to the controller. The standard lengths are 3 m and 5 m, but other lengths can also be specified in meters up to 20 m (e.g., 10L = 10 m).

* Refer to page 59 for other points to note.

Cable Track Specification (Cable Management Code: CT)

Dimensions

* The standard cable management specification of the XYB-D is the cable track. (Self-standing cable is not available.)

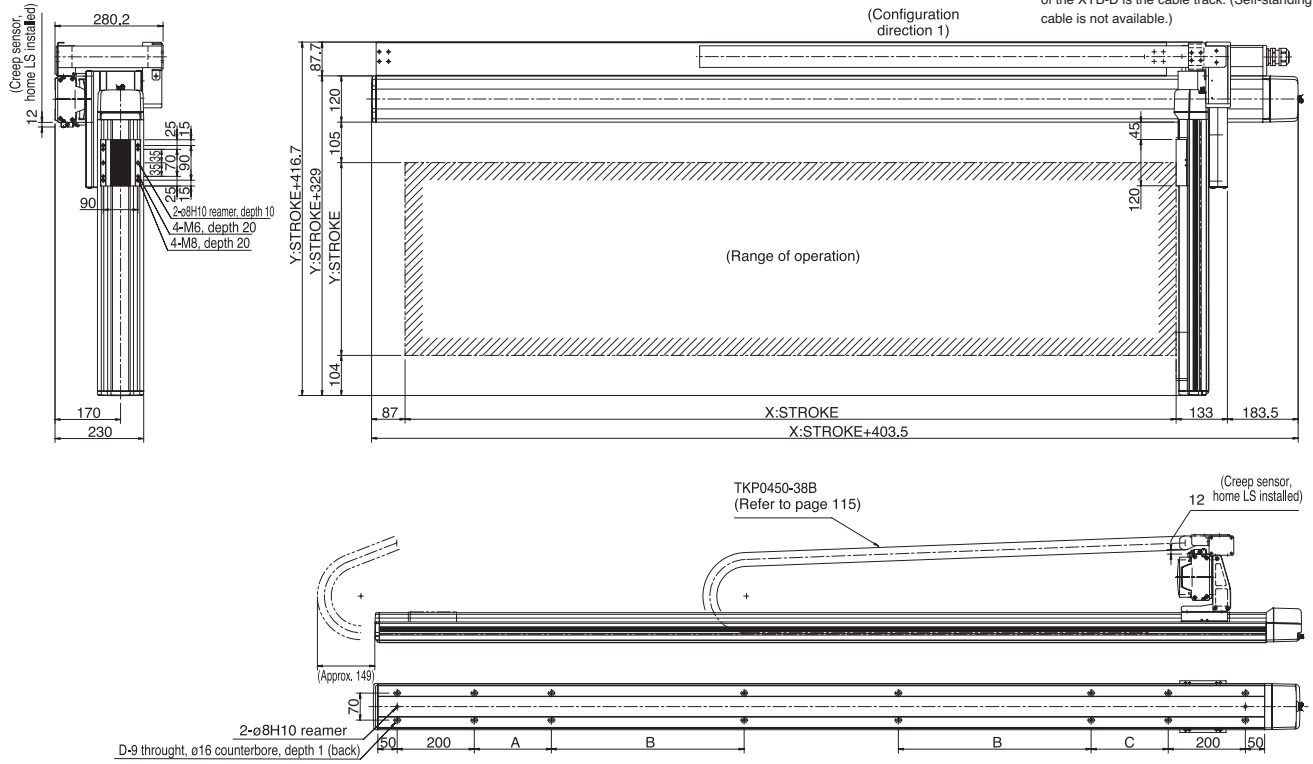

X stroke	800	900	1000	1100	1200	1300	1400	1500	1600	1700	1800	1900	2000
A	0	0	200	250	300	350	400	450	500	550	200	200	200
B	0	0	0	0	0	0	0	0	0	0	400	450	500
C	200	200	200	250	300	350	400	450	500	550	200	200	200
D	10	10	12	12	12	12	12	12	12	12	16	16	16

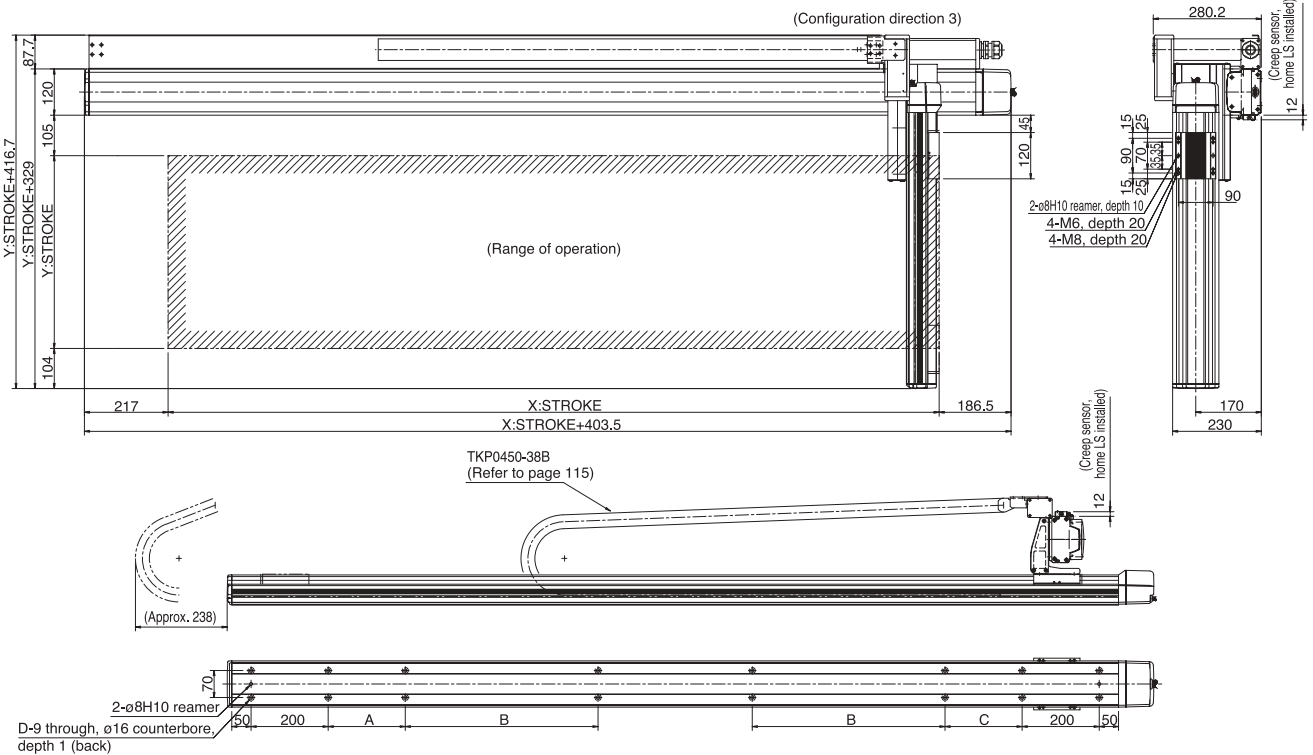

X stroke	800	900	1000	1100	1200	1300	1400	1500	1600	1700	1800	1900	2000
A	0	0	200	250	300	350	400	450	500	550	200	200	200
B	0	0	0	0	0	0	0	0	0	0	400	450	500
C	200	200	200	250	300	350	400	450	500	550	200	200	200
D	10	10	12	12	12	12	12	12	12	12	16	16	16

ICSA2-BE□H

Cartesian Robot: X-Y 2-Axes Configuration, XYB (Y-Axis Base Mount) Type

ICSPA2-BE□H

Cartesian Robot: X-Y 2-Axes Configuration, XYB (Y-Axis Base Mount) Type **High-Precision Specification**

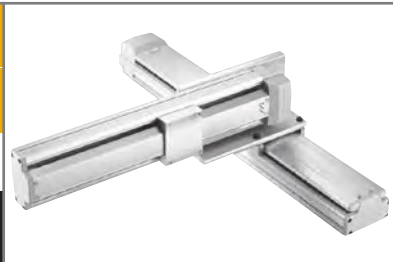

Type	XYB type	Stroke	X-axis: 300~1000mm Y-axis: 200~700mm	Load capacity	40kg ~ 19.3kg			
Model specification items	Series	Type	Encoder type	X-axis stroke + options	Y-axis stroke + options	Applicable controller	Cable length	Cable management
	ICSA2	BE1H	A	100AQLNM	70AQL	T1	5L	SC

* Refer to page 61 for the details of model specification items.

Models/Specifications

Model	Axis configuration		Encoder type	Motor output (W)	Lead (mm)	Stroke (mm) In increments of 100mm	Speed (mm/s) (Note 1)	Load capacity (Note 2)	Positioning repeatability (mm) (Note 3)
ICSA2 [ICSPA2] -BE□H-A-***-***-T1-△-○	X-axis	ISA [ISPA] -LXM-A-400-20-***-T1	Absolute	400	20	300 ~ 1000	1 ~ 1000	40 ~ 19.3	0.02 [0.01]
	Y-axis	ISA [ISPA] -MYM-A-200-20-***-T1		200		200 ~ 700			
ICSA2 [ICSPA2] -BE□H-I-***-***-T1-△-○	X-axis	ISA [ISPA] -LXM-I-400-20-***-T1	Incremental	400		300 ~ 1000			
	Y-axis	ISA [ISPA] -MYM-I-200-20-***-T1		200		200 ~ 700			

* In the above model names, □ indicates the configuration direction, *** the stroke/applicable options (stroke is specified in centimeters), △ the cable length and ○ the wiring.

Options

Name	Code	Page	Remarks
AQ seal	AQ	P13	
Brake	B	P13	
Creep sensor	C	P13	
Home limit switch	L	P14	
Reverse homing specification	NM	P14	
Guide with ball-retaining mechanism	RT	P14	

Common Specifications

Drive system (Note 4)	Ball screw, rolled C10 [equivalent to rolled C5]
Backlash (Note 5)	0.05mm or less [0.02mm or less]
Guide	Integrated with base
Base	Material: Aluminum with white alumite treatment
Cable length (Note 6)	3L: 3m, 5L: 5m, □L : Length specification
Cable management	SC: Self-standing cable CT: Cable track

Load Capacity by Acceleration (kg)

Acceleration (G)	200	300	400	500	600	700
0.3	40.0	40.0	33.0	27.3	22.9	19.3
0.4	30.0	30.0	30.0	27.3	22.9	19.3
0.5	24.0	24.0	24.0	24.0	22.9	19.3
0.6	20.0	20.0	20.0	20.0	20.0	19.3
0.7	17.0	17.0	17.0	17.0	17.0	16.0
0.8	15.0	15.0	14.6	13.5	12.5	11.5
0.9	13.5	12.6	11.6	10.5	9.5	8.5
1.0	10.6	9.6	8.6	7.5	6.5	5.5

Maximum Speed by Stroke (mm/sec)

Axis	200	300 ~ 700	800	900	1000
X-axis	-	1000	-	830	690
Y-axis	1000	-	-	-	-

Configuration direction

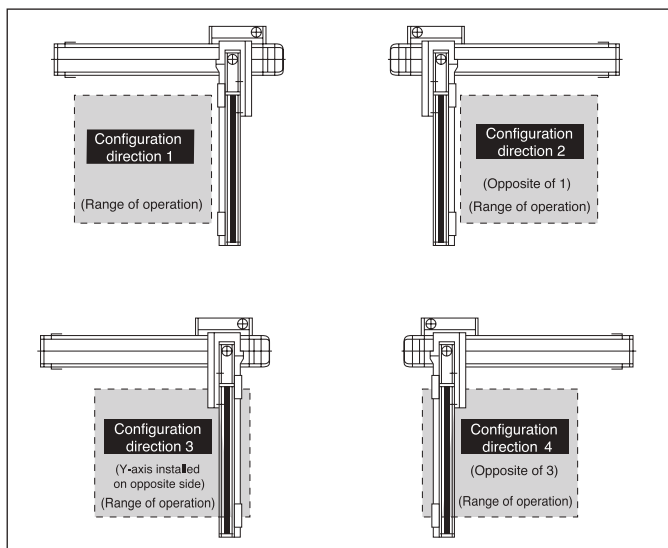

Applicable Controller Specifications

Applicable controller	Controller type	Model	Page
X-SEL	General-purpose type	XSEL-K-2-400□-200□-□-□□□-□-□	
	Compact type	XSEL-J-2-400□-200□-□-□□□-□-□	

Caution

(Note 1) The maximum speed will vary depending on the stroke. (Refer to the table of maximum speed by stroke.)

(Note 2) The load capacity assumes operation at the rated acceleration (0.3 G). The actuator can be operated at accelerations beyond the rated acceleration, but the load capacity will decrease (refer to the table of load capacity by acceleration).

(Notes 3, 4, 5) The figures in brackets apply to the ICSPA2.

(Note 6) The cable length measures from the X-axis connector box to the controller. The standard lengths are 3 m and 5 m, but other lengths can also be specified in meters up to 20 m (e.g., 10L = 10 m).

* Refer to page 59 for other points to note.

Self-standing Cable Specification (Cable Management Code: SC)

Dimensions

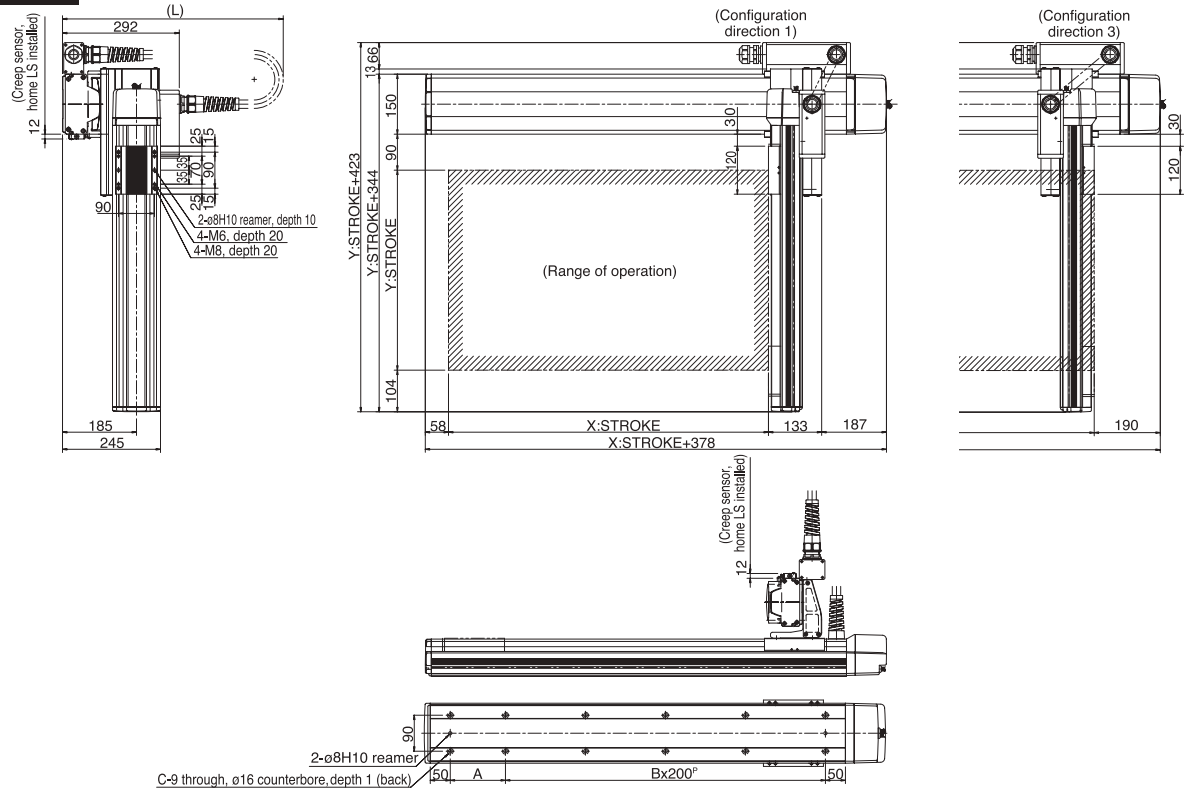

X stroke	300	400	500	600	700	800	900	1000
L	600	650	700	750	800	850	900	950
A	238	138	238	138	238	138	238	138
B	1	2	2	3	3	4	4	5
C	6	8	8	10	10	12	12	14

Cable Track Specification (Cable Management Code: CT)

Dimensions

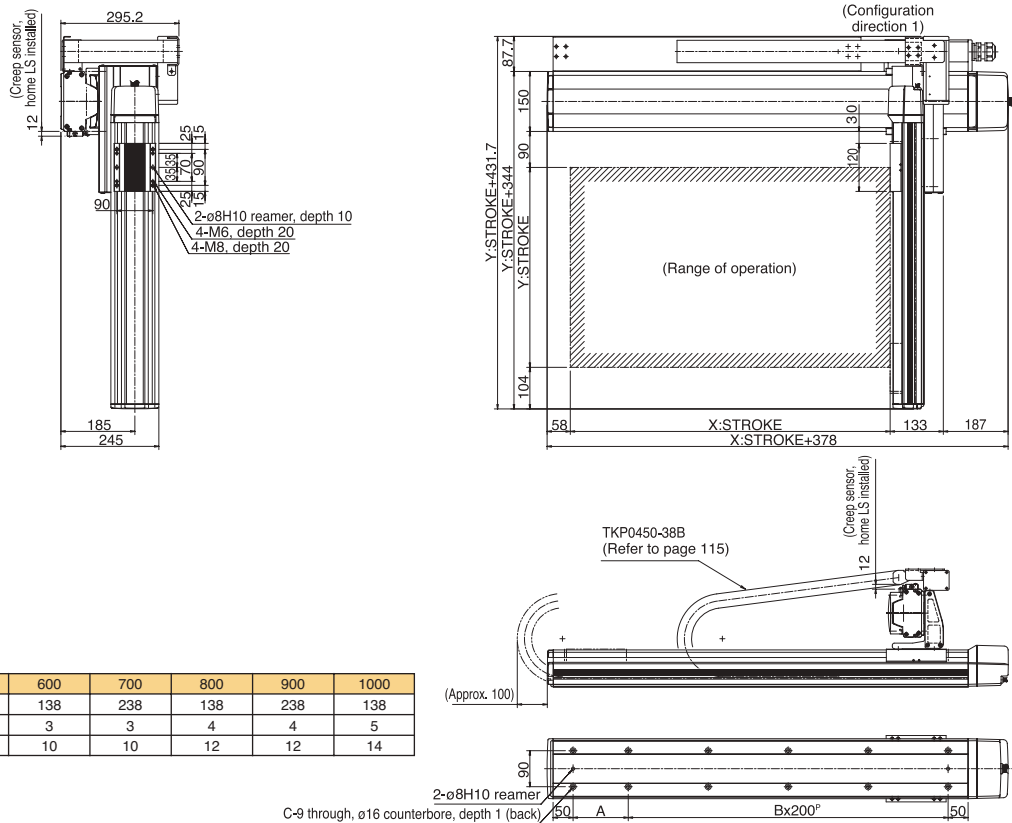

X stroke	300	400	500	600	700	800	900	1000
A	238	138	238	138	238	138	238	138
B	1	2	2	3	3	4	4	5
C	6	8	8	10	10	12	12	14

Single-Axis Robots
Cartesian Robots

ICSA2-BE□M Cartesian Robot: X-Y 2-Axes Configuration, XYB (Y-Axis Base Mount) Type

ICSPA2-BE□M Cartesian Robot: X-Y 2-Axes Configuration, XYB (Y-Axis Base Mount) Type **High-Precision Specification**

Type XYB type Stroke X-axis: 300~1000mm Y-axis: 200~700mm Load capacity 51.2kg ~ 19.3kg

Model specification items Series Type Encoder type X-axis stroke + options Y-axis stroke + options Applicable controller Cable length Cable management
 ICSA2 - BE1M - A - 100AQLNM - 70AQL - T1 - 5L - SC

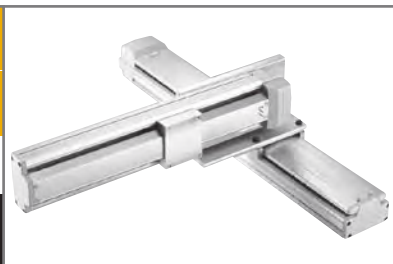

* Refer to page 61 for the details of model specification items.

Models/Specifications

Model	Axis configuration	Encoder type	Motor output (W)	Lead (mm)	Stroke (mm) In increments of 100mm	Speed (mm/s) (Note 1)	Load capacity (Note 2)	Positioning repeatability (mm) (Note 3)
ICSA2 [ICSPA2] -BE□M-A-***-***-T1-△-○	X-axis ISA [ISPA] -LXM-A-200-10-***-T1	Absolute	200	10	300 ~ 1000	1 ~ 500	51.2 ~ 19.3	0.02 [0.01]
	Y-axis ISA [ISPA] -MYM-A-200-10-***-T1				200 ~ 700			
ICSA2 [ICSPA2] -BE□M-I-***-***-T1-△-○	X-axis ISA [ISPA] -LXM-I-200-10-***-T1	Incremental	200	10	300 ~ 1000	1 ~ 500	51.2 ~ 19.3	0.02 [0.01]
	Y-axis ISA [ISPA] -MYM-I-200-10-***-T1				200 ~ 700			

* In the above model names, □ indicates the configuration direction, *** the stroke/applicable options (stroke is specified in centimeters), △ the cable length and ○ the wiring.

Options

Name	Code	Page	Remarks
AQ seal	AQ	P13	
Brake	B	P13	
Creep sensor	C	P13	
Home limit switch	L	P14	
Reverse homing specification	NM	P14	
Guide with ball-retaining mechanism	RT	P14	

Common Specifications

Drive system (Note 4)	Ball screw, rolled C10 [equivalent to rolled C5]
Backlash (Note 5)	0.05mm or less [0.02mm or less]
Guide	Integrated with base
Base	Material: Aluminum with white alumite treatment
Cable length (Note 6)	3L: 3m, 5L: 5m, □L: Length specification
Cable management	SC: Self-standing cable CT: Cable track

Load Capacity by Acceleration (kg)

Y-axis stroke (mm) / Acceleration (G)	200	300	400	500	600	700
0.3	51.2	40.5	33.0	27.3	22.9	19.3
0.4	46.6	40.5	33.0	27.3	22.9	19.3
0.5	35.1	34.1	33.0	27.3	22.9	19.3
0.6	26.6	25.6	24.6	23.5	22.5	19.3
0.7						
0.8						
0.9						
1.0						

Maximum Speed by Stroke (mm/sec)

Stroke (mm) / Axis	200	300 ~ 600	700	800	900	1000
X-axis	-	500		470	385	320
Y-axis	500		480	-	-	-

Configuration direction

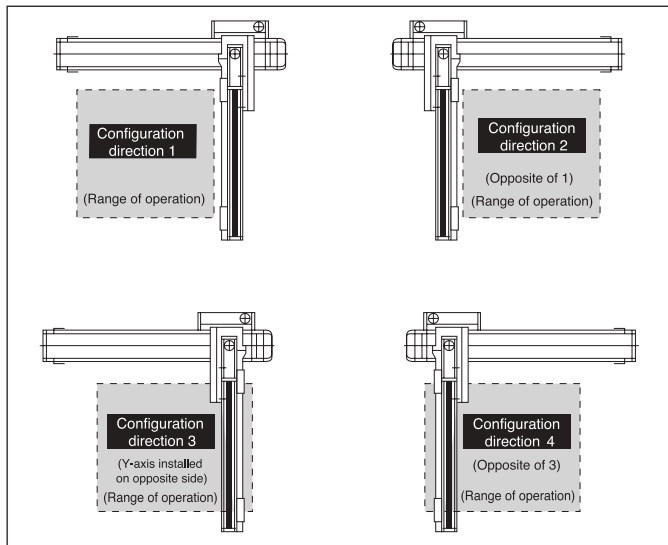

Applicable Controller Specifications

Applicable controller	Controller type	Model	Page
X-SEL	General-purpose type	XSEL-K-2-200□-200□-□-□□□-□-□	
	Compact type	XSEL-J-2-200□-200□-□-□□□-□-□	

Caution

(Note 1) The maximum speed will vary depending on the stroke. (Refer to the table of maximum speed by stroke.)
 (Note 2) The load capacity assumes operation at the rated acceleration (0.3 G). The actuator can be operated at accelerations beyond the rated acceleration, but the load capacity will decrease (refer to the table of load capacity by acceleration).
 (Notes 3, 4, 5) The figures in brackets apply to the ICSPA2.
 (Note 6) The cable length measures from the X-axis connector box to the controller. The standard lengths are 3 m and 5 m, but other lengths can also be specified in meters up to 20 m (e.g., 10L = 10 m).

* Refer to page 59 for other points to note.

Self-standing Cable reamer Specification (Cable Management Code: SC)

Dimensions

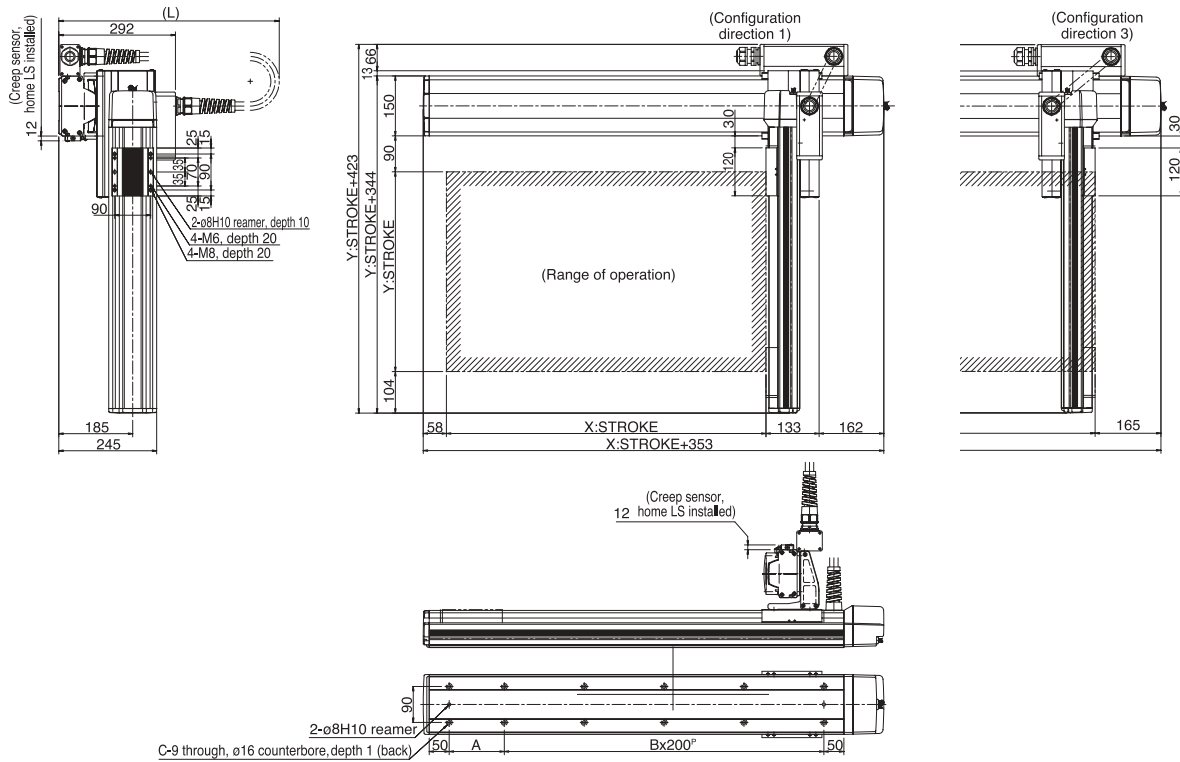

X stroke	300	400	500	600	700	800	900	1000
L	600	650	700	750	800	850	900	950
A	238	138	238	138	238	138	238	138
B	1	2	2	3	3	4	4	5
C	6	8	8	10	10	12	12	14

Cable Track Specification (Cable Management Code: CT)

Dimensions

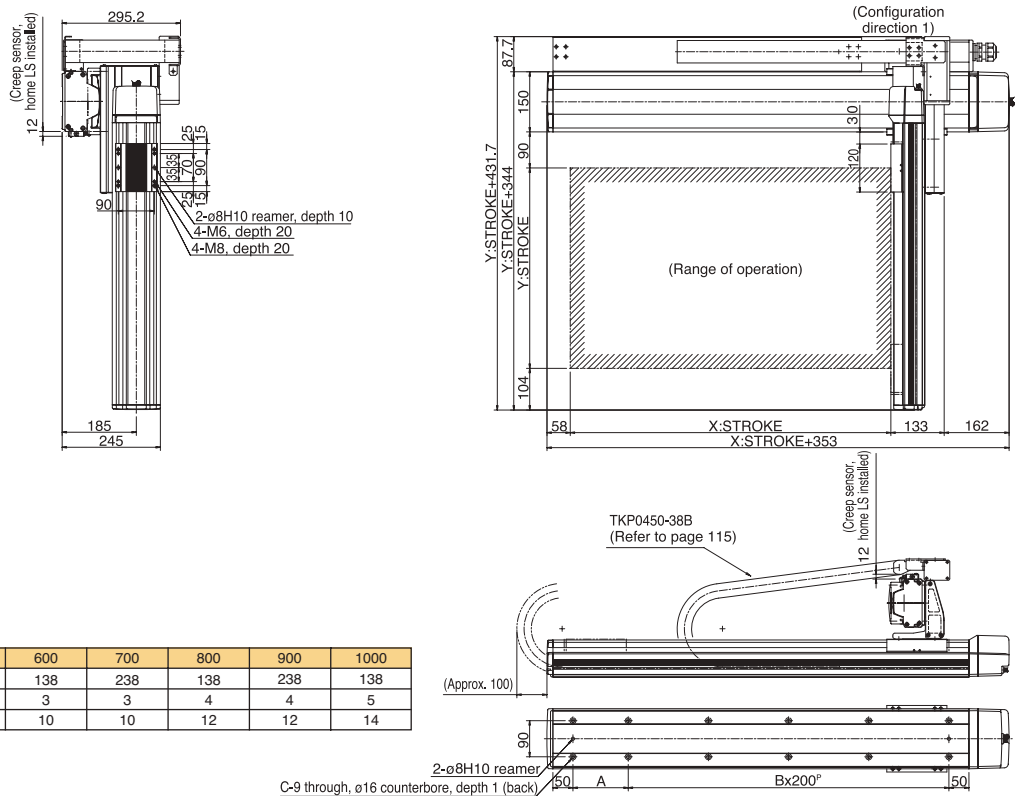

X stroke	300	400	500	600	700	800	900	1000
A	238	138	238	138	238	138	238	138
B	1	2	2	3	3	4	4	5
C	6	8	8	10	10	12	12	14

ICSA2-BF□H Cartesian Robot: X-Y 2-Axes Configuration, XYB (Y-Axis Base Mount) Type

ICSPA2-BF□H Cartesian Robot: X-Y 2-Axes Configuration, XYB (Y-Axis Base Mount) Type **High-Precision Specification**

Type **XYB type** Stroke X-axis: 1000~2500mm Y-axis: 200~700mm Load capacity **40kg ~ 19.3kg**

Model specification items Series **ICSA2** - Type **BF1H** - Encoder type **A** - X-axis stroke + options **250AQLNM** - Y-axis stroke + options **70AQL** - Applicable controller **T1** - Cable length **5L** - Cable management **CT**

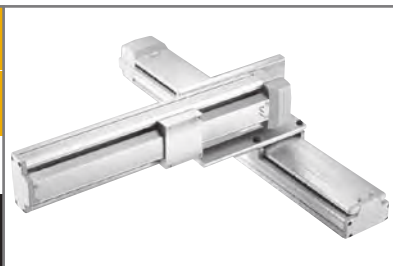

* Refer to page 61 for the details of model specification items.

Models/Specifications

Model	Axis configuration	Encoder type	Motor output (W)	Lead (mm)	Stroke (mm) In increments of 100mm	Speed (mm/s) (Note 1)	Load capacity (Note 2)	Positioning repeatability (mm) (Note 3)
ICSA2 [ICSPA2] -BF□H-A-***-***-T1-△-CT	X-axis ISA [ISPA] -LXMX-A-400-20-***-T1	Absolute	400	20	1000 ~ 2500	1 ~ 1000	40 ~ 19.3	±0.02 [±0.01]
	Y-axis ISA [ISPA] -MYM-A-200-20-***-T1		200		200 ~ 700			
ICSA2 [ICSPA2] -BF□H-I-***-***-T1-△-CT	X-axis ISA [ISPA] -LXMX-I-400-20-***-T1	Incremental	400	20	1000 ~ 2500	1 ~ 1000	40 ~ 19.3	±0.02 [±0.01]
	Y-axis ISA [ISPA] -MYM-I-200-20-***-T1		200		200 ~ 700			

* In the above model names, □ indicates the configuration direction, *** the stroke/applicable options (stroke is specified in centimeters), △ the cable length.

Options

Name	Code	Page	Remarks
AQ seal	AQ	P13	
Brake	B	P13	
Creep sensor	C	P13	
Home limit switch	L	P14	
Reverse homing specification	NM	P14	
Guide with ball-retaining mechanism	RT	P14	

Common Specifications

Drive system (Note 4)	Ball screw, rolled C10 [equivalent to rolled C5]
Backlash (Note 5)	0.05mm or less [0.02mm or less]
Guide	Integrated with base
Base	Material: Aluminum with white alumite treatment
Cable length (Note 6)	3L: 3m, 5L: 5m, □L: Length specification
Cable management	CT: Cable track

Load Capacity by Acceleration (kg)

Acceleration (G) \ Y-axis stroke (mm)	200	300	400	500	600	700
0.3	40.0	40.0	33.0	27.3	22.9	19.3
0.4						
0.5						
0.6						
0.7						
0.8						
0.9						
1.0						

Maximum Speed by Stroke (mm/sec)

Axis \ Stroke (mm)	200 ~ 700	1000 ~ 1400	1500	1600	1700	1800	1900	2000	2500
X-axis	-	1000	950	830	740	650	590	540	340
Y-axis	1000	-	-	-	-	-	-	-	-

Applicable Controller Specifications

Applicable controller	Controller type	Model	Page
X-SEL	General-purpose type	XSEL-K-2-400□-200□-□-□□□-□-□	
	Compact type	XSEL-J-2-400□-200□-□-□□□-□-□	

Caution

(Note 1) The maximum speed will vary depending on the stroke. (Refer to the table of maximum speed by stroke.)
 (Note 2) The load capacity assumes operation at the rated acceleration (0.3 G). The rated acceleration is the maximum specifiable acceleration for both the ICSA2 and ICSPA2.
 (Notes 3, 4, 5) The figures in brackets apply to the ICSPA2.
 (Note 6) The cable length measures from the X-axis connector box to the controller. The standard lengths are 3 m and 5 m, but other lengths can also be specified in meters up to 20 m (e.g., 10L = 10 m).

Configuration direction

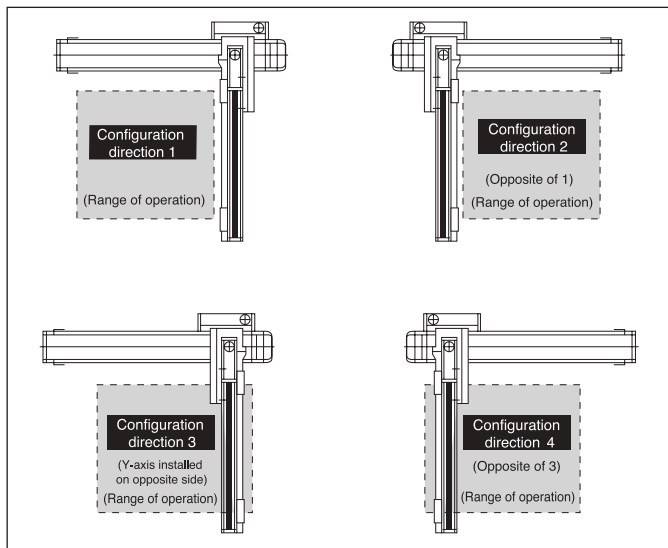

Cable Track Specification (Cable Management Code: CT)

Dimensions

* Note that changing the home direction will require the actuator to be returned to IAI for adjustment.

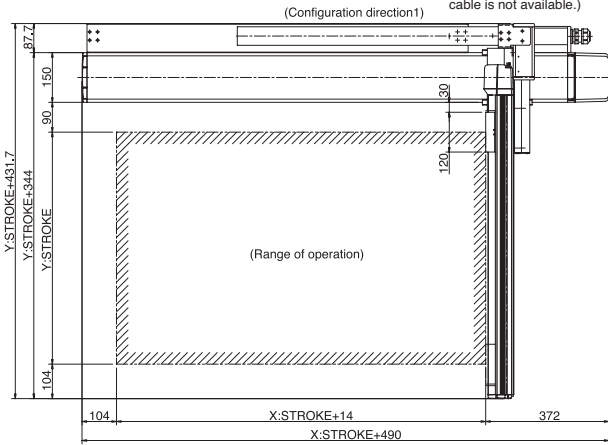
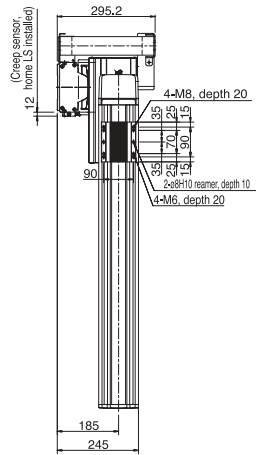

* The standard cable management specification of the XYB-F is the cable track. (Self-standing cable is not available.)

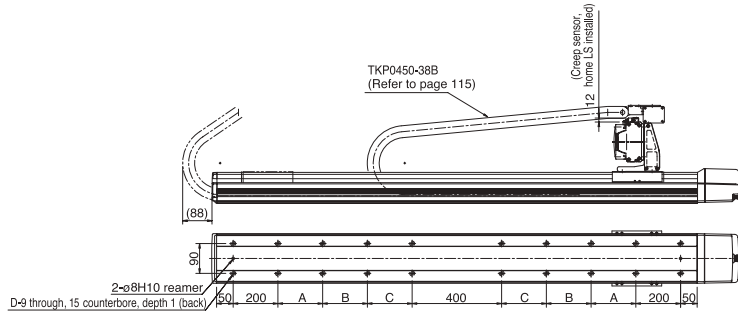

X stroke	1000	1100	1200	1300	1400	1500	1600	1700	1800	1900	2000	2100	2200	2300	2400	2500
A	225	275	325	375	425	475	525	575	200	200	200	200	200	200	200	200
B	0	0	0	0	0	0	0	0	425	475	525	575	200	200	200	200
C	0	0	0	0	0	0	0	0	0	0	0	0	425	475	525	575
D	12	12	12	12	12	12	12	12	16	16	16	16	20	20	20	20

* Note that changing the home direction will require the actuator to be returned to IAI for adjustment.

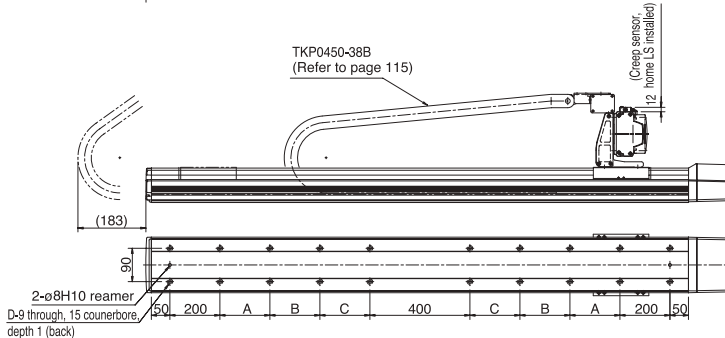
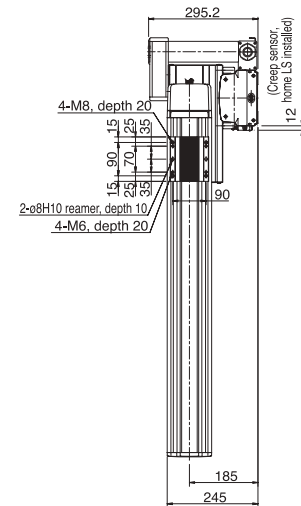
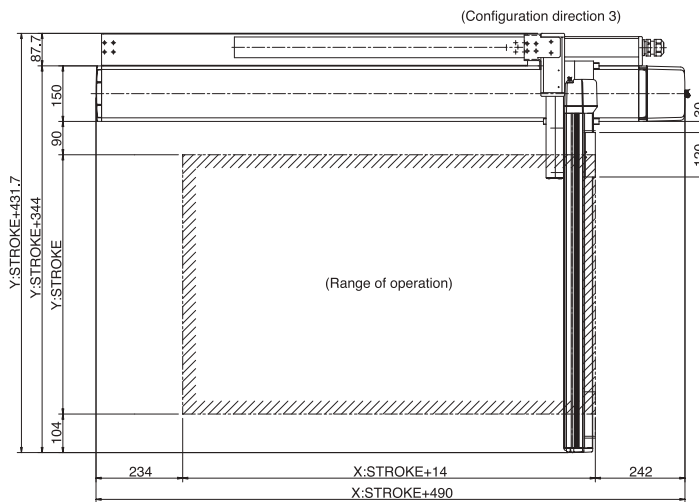

X stroke	1000	1100	1200	1300	1400	1500	1600	1700	1800	1900	2000	2100	2200	2300	2400	2500
A	225	275	325	375	425	475	525	575	200	200	200	200	200	200	200	200
B	0	0	0	0	0	0	0	0	425	475	525	575	200	200	200	200
C	0	0	0	0	0	0	0	0	0	0	0	0	425	475	525	575
D	12	12	12	12	12	12	12	12	16	16	16	16	20	20	20	20

ICSA2-BK□H Cartesian Robot: X-Y 2-Axes Configuration XYB (Y-Axis Base Mount) Type

ICSPA2-BK□H Cartesian Robot: X-Y 2-Axes Configuration XYB (Y-Axis Base Mount) Type High-Precision Specification

Model specification items	Series	BK□H Type	Encoder type	Axis 1 stroke	Options	Axis 2 stroke	Options	Applicable controller	Cable length	Y-axis cable wiring	Z-axis cable wiring (optional)
ICSA2: Standard 2-axis Specification ICSPA2: High-Precision 2-axis Specification	Standard	Refer to the "Models/Specifications" table below.	A: Absolute I: Incremental	30:300mm 130:1300mm (every 100mm)	Refer to the "Options" table below.	30:300mm 70:700mm (every 100mm)	Refer to the "Options" table below.	T1: XSEL-K T2: SCON XSEL-P/Q	3L: 3 m 5L: 5 m □L: Length specification	CTL: Cable track, size L	CTM: Cable track, size M



* Refer to page 61 for the details of model specification items.

Models/Specifications

Encoder type	XY-axis configuration direction (*)	Precision specification	Model
Absolute	1	Standard Specification	ICSA2-BK1H-A-①A3-②-③-④-⑤-⑥
		High-Precision Specification	ICSPA2-BK1H-A-①A3-②-③-④-⑤-⑥
	2	Standard Specification	ICSA2-BK2H-A-①A1-②-③-④-⑤-⑥
		High-Precision Specification	ICSPA2-BK2H-A-①A1-②-③-④-⑤-⑥
	3	Standard Specification	ICSA2-BK3H-A-①A3-②-③-④-⑤-⑥
		High-Precision Specification	ICSPA2-BK3H-A-①A3-②-③-④-⑤-⑥
	4	Standard Specification	ICSA2-BK4H-A-①A1-②-③-④-⑤-⑥
		High-Precision Specification	ICSPA2-BK4H-A-①A1-②-③-④-⑤-⑥
Incremental	1	Standard Specification	ICSA2-BK1H-I-①A3-②-③-④-⑤-⑥
		High-Precision Specification	ICSPA2-BK1H-I-①A3-②-③-④-⑤-⑥
	2	Standard Specification	ICSA2-BK2H-I-①A1-②-③-④-⑤-⑥
		High-Precision Specification	ICSPA2-BK2H-I-①A1-②-③-④-⑤-⑥
	3	Standard Specification	ICSA2-BK3H-I-①A3-②-③-④-⑤-⑥
		High-Precision Specification	ICSPA2-BK3H-I-①A3-②-③-④-⑤-⑥
	4	Standard Specification	ICSA2-BK4H-I-①A1-②-③-④-⑤-⑥
		High-Precision Specification	ICSPA2-BK4H-I-①A1-②-③-④-⑤-⑥

* Refer to the figure below for XY-axis configuration direction. Refer to the table on the right for what ① to ⑥ indicate in the above model codes.

XY Configuration Direction

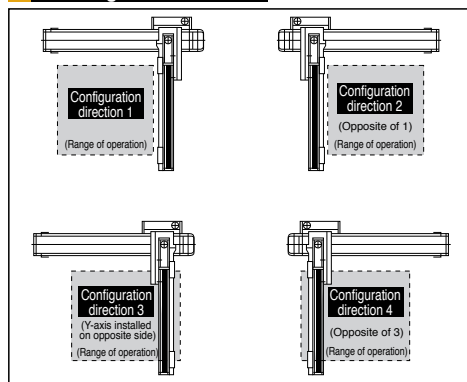

Axis Configuration * [] is for the high-precision specification.

Axis Type	Model	Page
X-axis	ISA[ISPA]-WXM-①-600-40-(stroke)-②	→P35
Y-axis	ISA[ISPA]-LYM-①-400-40-(stroke)	→P32

* ① in the above model codes indicates the encoder type which may be either A (absolute) or I (incremental).

* ② in the above model codes indicates either A1 or A3.
A1 or A3 indicates the cable exit direction for the X-axis.

A1: Specify this code for XY configuration direction 2 or 4.
A3: Specify this code for XY configuration direction 1 or 3.

Payload by Acceleration (kg) (Note 4)

Acceleration		Y-axis stroke				
		300	400	500	600	700
0.3	0.3	31.7	30.2	28.8	27.5	26.0
	0.4	18.2	16.7	15.2	14.0	12.5
	0.5	10.1	8.6	7.2	5.9	4.4
	0.6	4.7	3.2	1.8	0.5	—
	0.7	1.1	—	—	—	—
	0.8	—	—	—	—	—
	0.9	—	—	—	—	—
1.0	—	—	—	—	—	

Explanation of Model Code

Number	Contents	Notation
①	X-axis stroke (Note 1)	30:300 mm 130:1300 mm
②	Y-axis stroke (Note1)	30:300 mm 70:700 mm
③	Applicable controller	T1: XSEL-K T2: XSEL-P/Q, SCON
④	Cable length (Note 2)	3L: 3 m 5L: 5 m □L: □m
⑤	Y-axis cable wiring	CTL: Cable track, size L
⑥	Z-axis cable wiring (Option)	CTM: Cable track, size M

* What ① to ⑥ indicate in the model codes on the left are explained above.

Options

Please add the option codes at the end of each stroke of the axis. When adding multiple options, put together in alphabetic order.

Name	Code	Page
AQ seal	AQ	→P13
Brake	B	→P13
Creep sensor	C	→P13
Home limit switch	L	→P14
Reverse homing specification	NM	→P14
Guide with ball-retaining mechanism	RT	→P14

Common Specifications * [] is for the high-precision specification.

Drive system	Ball screw, rolled C10 [equivalent to rolled C5]
Positioning repeatability	± 0.02 mm [± 0.01 mm]
Lost motion	0.05 mm or less [0.02 mm or less]
Guide	Integrated with base
Base	Material: Aluminum with white alumite treatment
X-axis motor output/lead	600W/40 mm
Y-axis motor output/lead	400W/40 mm

Maximum Speed by Stroke (mm/sec) (Note 3)

	300 ~ 700	800	900	1000	1100	1200	1300
X-axis	2400	1840	1530	1290	1100	950	—
Y-axis	2400	—	—	—	—	—	—

	(Note 1)	Strokes in the model codes are in cm (centimeters).
	(Note 2)	The cable length measures from the X-axis connector box to the controller. The standard lengths are 3 m and 5 m, but other lengths can also be specified in meters up to 20 m.
	(Note 3)	Take note that the longer the stroke, the lower the maximum speed becomes.
	(Note 4)	The rated acceleration is 0.3 G. Raising the acceleration lowers the payload.

ICSA2[ICSPA2]-BK□H-CT(Cable Track Specification)

Dimensions (Combination direction 1)

CAD drawings can be downloaded from the website.

2D CAD RoHS

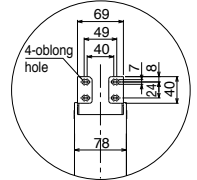

Z-axis cable wiring
Detail view of moving end of cable track

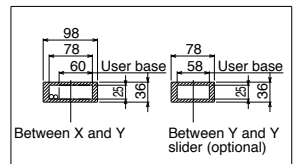
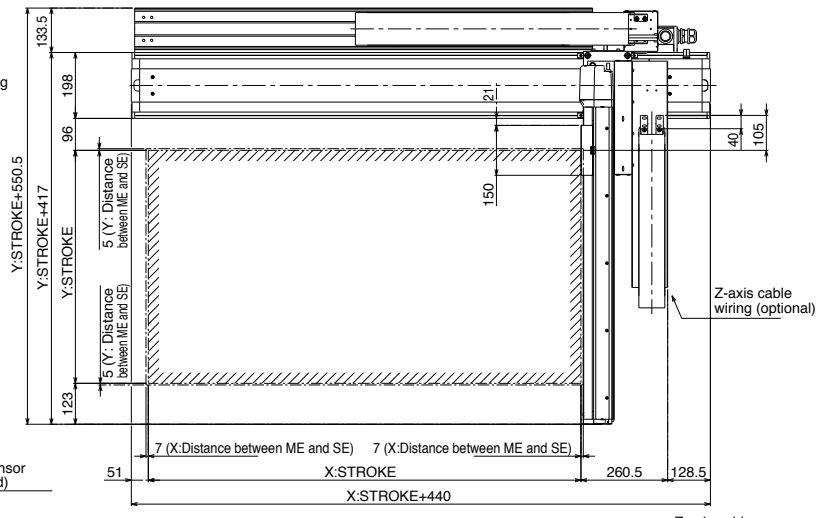
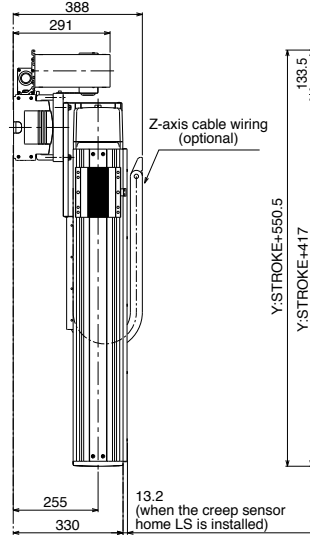

Section view of cable storage space

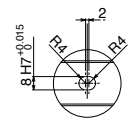

Detail view of P

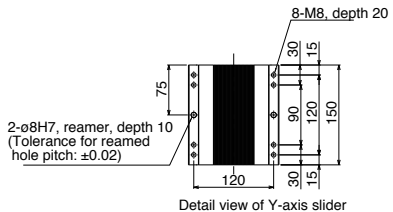
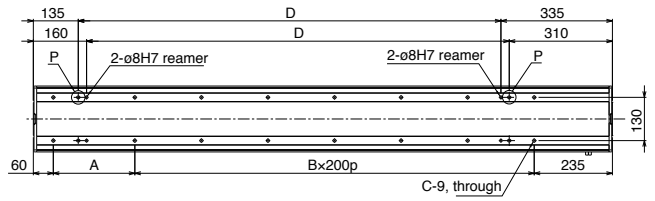
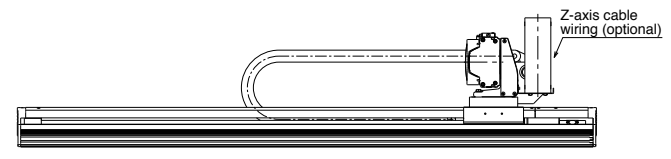

Detail view of Y-axis slider

Note
Secure the moving end of the cable track for the Z-axis cable wiring to a plate, etc., installed to the Y-axis slider by the customer.

X stroke	300	350	400	450	500	550	600	650	700	750	800	850	900	950	1000	1050	1100	1150	1200	1250	1300
A	245	295	145	195	245	295	145	195	245	295	145	195	245	295	145	195	245	295	145	195	245
B	1	1	2	2	2	2	3	3	3	3	4	4	4	4	5	5	5	5	6	6	6
C	6	6	8	8	8	8	10	10	10	10	12	12	12	12	14	14	14	14	16	16	16
D	270	320	370	420	470	520	570	620	670	720	770	820	870	920	970	1020	1070	1120	1170	1220	1270

ICSA2-BK□M Cartesian Robot: X-Y 2-Axes Configuration
XYB (Y-Axis Base Mount) Type

ICSPA2-BK□M Cartesian Robot: X-Y 2-Axes Configuration
XYB (Y-Axis Base Mount) Type **High-Precision Specification**

Model specification items	Series	BK□M Type	Encoder type	Axis 1 stroke	Options	Axis 2 stroke	Options	Applicable controller	Cable length	Y-axis cable wiring	Z-axis cable wiring (optional)
ICSA2: Standard 2-axis Specification ICSPA2: High-Precision 2-axis Specification	Standard	Refer to the "Models/Specifications" table below.	A: Absolute I: Incremental	30:300mm 130:1300mm (every 100mm)	Refer to the "Options" table below.	30:300mm 70:700mm (every 100mm)	Refer to the "Options" table below.	T1: XSEL-K T2: SCON XSEL-P/Q	3L: 3 m 5L: 5 m □L: Length specification	CTL: Cable track, size L	CTM: Cable track, size M



* Refer to page 61 for the details of model specification items.

Models/Specifications

Encoder type	XY-axis configuration direction (*)	Precision specification	Model
Absolute	1	Standard Specification	ICSA2-BK1M-A-①A3-②-③-④-⑤-⑥
		High-Precision Specification	ICSPA2-BK1M-A-①A3-②-③-④-⑤-⑥
	2	Standard Specification	ICSA2-BK2M-A-①A1-②-③-④-⑤-⑥
		High-Precision Specification	ICSPA2-BK2M-A-①A1-②-③-④-⑤-⑥
	3	Standard Specification	ICSA2-BK3M-A-①A3-②-③-④-⑤-⑥
		High-Precision Specification	ICSPA2-BK3M-A-①A3-②-③-④-⑤-⑥
	4	Standard Specification	ICSA2-BK4M-A-①A1-②-③-④-⑤-⑥
		High-Precision Specification	ICSPA2-BK4M-A-①A1-②-③-④-⑤-⑥
Incremental	1	Standard Specification	ICSA2-BK1M-I-①A3-②-③-④-⑤-⑥
		High-Precision Specification	ICSPA2-BK1M-I-①A3-②-③-④-⑤-⑥
	2	Standard Specification	ICSA2-BK2M-I-①A1-②-③-④-⑤-⑥
		High-Precision Specification	ICSPA2-BK2M-I-①A1-②-③-④-⑤-⑥
	3	Standard Specification	ICSA2-BK3M-I-①A3-②-③-④-⑤-⑥
		High-Precision Specification	ICSPA2-BK3M-I-①A3-②-③-④-⑤-⑥
	4	Standard Specification	ICSA2-BK4M-I-①A1-②-③-④-⑤-⑥
		High-Precision Specification	ICSPA2-BK4M-I-①A1-②-③-④-⑤-⑥

* Refer to the figure below for XY-axis configuration direction. Refer to the table on the right for what ① to ⑥ indicate in the above model codes.

XY Configuration Direction

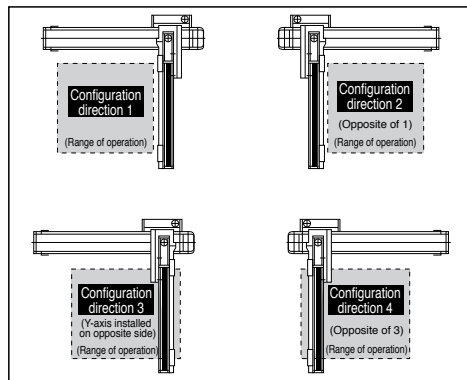

Axis Configuration * [] is for the high-precision specification.

Axis Type	Model	Page
X-axis	ISA[ISPA]-WXM-①-600-20-(stroke)-②	→P35
Y-axis	ISA[ISPA]-LYM-①-400-20-(stroke)	→P32

* ① in the above model codes indicates the encoder type which may be either A (absolute) or I (incremental).

* ② in the above model codes indicates either A1 or A3.
A1 or A3 indicates the cable exit direction for the X-axis.

A1: Specify this code for XY configuration direction 2 or 4.
A3: Specify this code for XY configuration direction 1 or 3.

Payload by Acceleration (kg) (Note 4)

Acceleration		Y-axis stroke				
		300	400	500	600	700
0.3	0.3	62.3	49.8	40.7	33.7	28.1
	0.4	54.5	49.8	40.7	33.7	28.1
	0.5	42.5	41.0	39.6	33.7	28.1
	0.6	31.7	30.2	28.8	27.5	26.0
	0.7	24.5	23.0	21.6	20.3	18.8
	0.8	18.2	16.7	15.3	14.0	12.5
	0.9	13.7	12.2	10.8	9.5	8.0
1.0	10.1	8.6	7.2	5.9	4.4	

Explanation of Model Code

Number	Contents	Notation
①	X-axis stroke (Note 1)	30:300 mm 130:1300 mm
②	Y-axis stroke (Note1)	30:300 mm 70:700 mm
③	Applicable controller	T1: XSEL-K T2: XSEL-P/Q, SCON
④	Cable length (Note 2)	3L: 3 m 5L: 5 m □L: □m
⑤	Y-axis cable wiring	CTL: Cable track, size L
⑥	Z-axis cable wiring (Option)	CTM: Cable track, size M

* What ① to ⑥ indicate in the model codes on the left are explained above.

Options

Please add the option codes at the end of each stroke of the axis. When adding multiple options, put together in alphabetic order.

Name	Code	Page
AQ seal	AQ	→P13
Brake	B	→P13
Creep sensor	C	→P13
Home limit switch	L	→P14
Reverse homing specification	NM	→P14
Guide with ball-retaining mechanism	RT	→P14

Common Specifications * [] is for the high-precision specification.

Drive system	Ball screw, rolled C10 [equivalent to rolled C5]
Positioning repeatability	± 0.02 mm [± 0.01 mm]
Lost motion	0.05 mm or less [0.02 mm or less]
Guide	Integrated with base
Base	Material: Aluminum with white alumite treatment
X-axis motor output/lead	600W/20 mm
Y-axis motor output/lead	400W/20 mm

Maximum Speed by Stroke (mm/sec) (Note 3)

	300 ~ 700	800	900	1000	1100	1200	1300
X-axis	1200	920	765	645	550	475	
Y-axis	1200	—	—	—	—	—	—

CAUTION

(Note 1) Strokes in the model codes are in cm (centimeters).
 (Note 2) The cable length measures from the X-axis connector box to the controller. The standard lengths are 3 m and 5 m, but other lengths can also be specified in meters up to 20 m.
 (Note 3) Take note that the longer the stroke, the lower the maximum speed becomes.
 (Note 4) The rated acceleration is 0.3 G. Raising the acceleration lowers the payload.

ICSA2[ICSPA2]-BK□M-CT(Cable Track Specification)

Dimensions (Combination direction 1)

CAD drawings can be downloaded from the website.

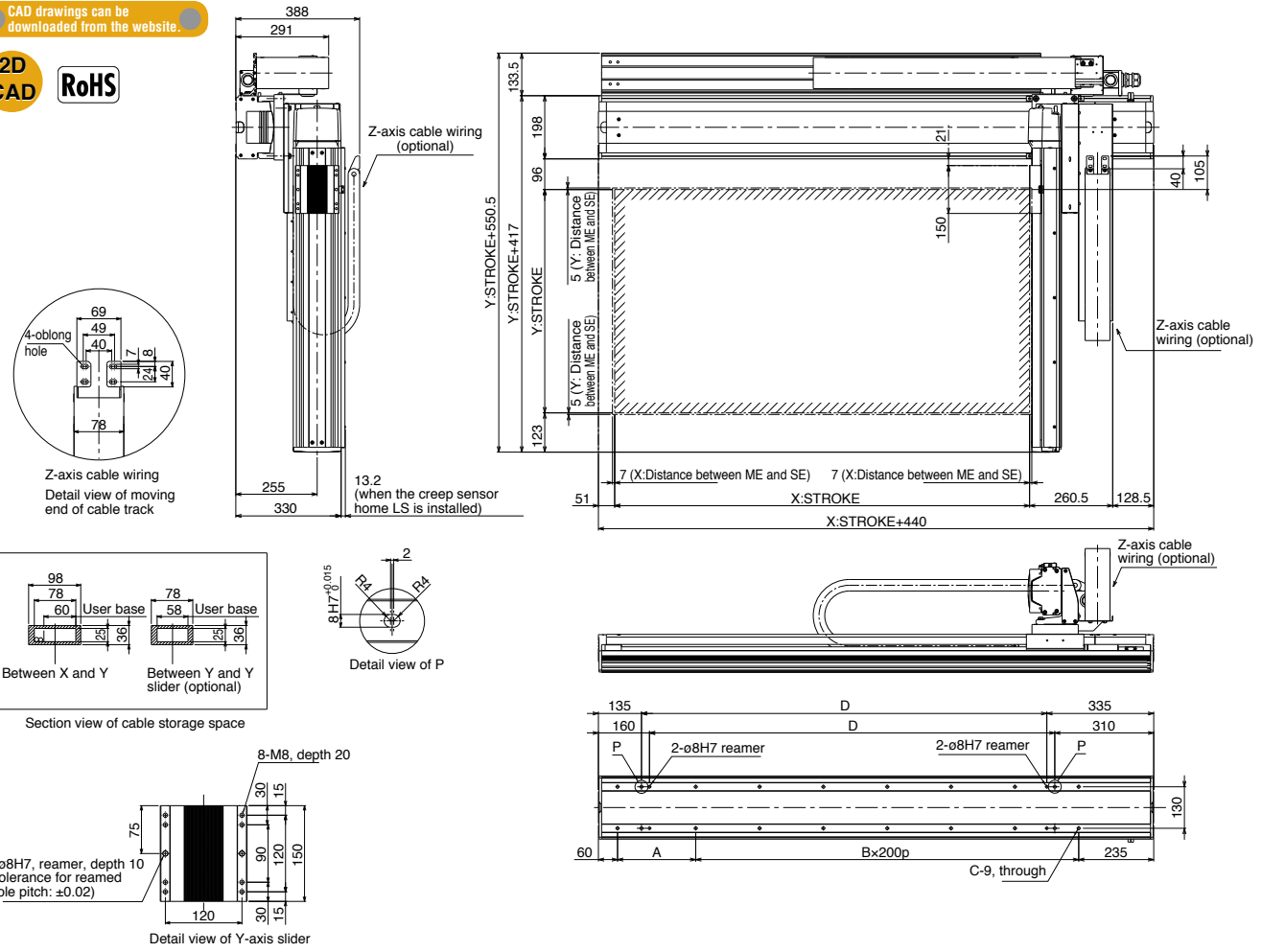

Note
Secure the moving end of the cable track for the Z-axis cable wiring to a plate, etc., installed to the Y-axis slider by the customer.

X stroke	300	350	400	450	500	550	600	650	700	750	800	850	900	950	1000	1050	1100	1150	1200	1250	1300
A	245	295	145	195	245	295	145	195	245	295	145	195	245	295	145	195	245	295	145	195	245
B	1	1	2	2	2	2	3	3	3	3	4	4	4	4	5	5	5	5	6	6	6
C	6	6	8	8	8	8	10	10	10	10	12	12	12	12	14	14	14	14	16	16	16
D	270	320	370	420	470	520	570	620	670	720	770	820	870	920	970	1020	1070	1120	1170	1220	1270

ICSA2-BL□H

Cartesian Robot: X-Y 2-Axes Configuration
XYB (Y-Axis Base Mount) Type

ICSPA2-BL□H

Cartesian Robot: X-Y 2-Axes Configuration
XYB (Y-Axis Base Mount) Type **High-Precision Specification**

Model specification items	Series	BL□H Type	Encoder type	Axis 1 stroke	Options	Axis 2 stroke	Options	Applicable controller	Cable length	Y-axis cable wiring	Z-axis cable wiring (optional)
ICSA2: Standard 2-axis Specification ICSPA2: High-Precision 2-axis Specification	Standard	Refer to the "Models/Specifications" table below.	A: Absolute I: Incremental	9090mm 250:2500mm (every 100mm)	Refer to the "Options" table below.	30:300mm 70:700mm (every 100mm)	Refer to the "Options" table below.	T1: XSEL-K T2: SCON XSEL-P/Q	3L: 3 m 5L: 5 m □L: Length specification	CTL: Cable track, size L	CTM: Cable track, size M



* Refer to page 61 for the details of model specification items.

Models/Specifications

Encoder type	XY-axis configuration direction (*)	Precision specification	Model
Absolute	1	Standard Specification	ICSA2-BL1H-A-①A3-②-③-④-⑤-⑥
		High-Precision Specification	ICSPA2-BL1H-A-①A3-②-③-④-⑤-⑥
	2	Standard Specification	ICSA2-BL2H-A-①A1-②-③-④-⑤-⑥
		High-Precision Specification	ICSPA2-BL2H-A-①A1-②-③-④-⑤-⑥
	3	Standard Specification	ICSA2-BL3H-A-①A3-②-③-④-⑤-⑥
		High-Precision Specification	ICSPA2-BL3H-A-①A3-②-③-④-⑤-⑥
	4	Standard Specification	ICSA2-BL4H-A-①A1-②-③-④-⑤-⑥
		High-Precision Specification	ICSPA2-BL4H-A-①A1-②-③-④-⑤-⑥
Incremental	1	Standard Specification	ICSA2-BL1H-I-①A3-②-③-④-⑤-⑥
		High-Precision Specification	ICSPA2-BL1H-I-①A3-②-③-④-⑤-⑥
	2	Standard Specification	ICSA2-BL2H-I-①A1-②-③-④-⑤-⑥
		High-Precision Specification	ICSPA2-BL2H-I-①A1-②-③-④-⑤-⑥
	3	Standard Specification	ICSA2-BL3H-I-①A3-②-③-④-⑤-⑥
		High-Precision Specification	ICSPA2-BL3H-I-①A3-②-③-④-⑤-⑥
	4	Standard Specification	ICSA2-BL4H-I-①A1-②-③-④-⑤-⑥
		High-Precision Specification	ICSPA2-BL4H-I-①A1-②-③-④-⑤-⑥

* Refer to the figure below for XY-axis configuration direction. Refer to the table on the right for what ① to ⑥ indicate in the above model codes.

XY Configuration Direction

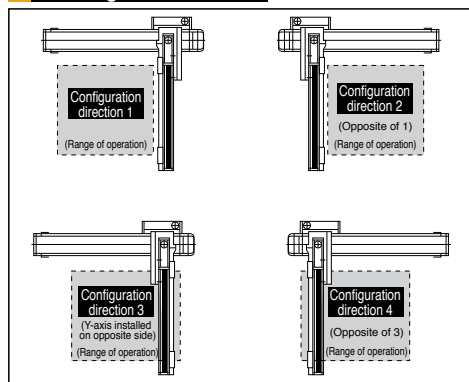

Axis Configuration

* [] is for the high-precision specification.

Axis Type	Model	Page
X-axis	ISA[ISPA]-WXM-①-600-40-(stroke)-②	→P37
Y-axis	ISA[ISPA]-LYM-①-400-40-(stroke)	→P32

* ① in the above model codes indicates the encoder type which may be either A (absolute) or I (incremental).

* ② in the above model codes indicates either A1 or A3.
A1 or A3 indicates the cable exit direction for the X-axis.

A1: Specify this code for XY configuration direction 2 or 4.
A3: Specify this code for XY configuration direction 1 or 3.

Payload by Acceleration (kg) (Note 4)

Acceleration		Y-axis stroke				
		300	400	500	600	700
0.3	0.3	31.7	30.2	28.8	27.5	26.0
	0.4	—	—	—	—	—
	0.5	—	—	—	—	—
	0.6	—	—	—	—	—
	0.7	—	—	—	—	—
	0.8	—	—	—	—	—
	0.9	—	—	—	—	—
1.0	—	—	—	—	—	

Explanation of Model Code

Number	Contents	Notation
①	X-axis stroke (Note 1)	90:900 mm 250:2500 mm
②	Y-axis stroke (Note1)	30:300 mm 70:700 mm
③	Applicable controller	T1: XSEL-K T2: XSEL-P/Q, SCON
④	Cable length (Note 2)	3L: 3 m 5L: 5 m □L: □m
⑤	Y-axis cable wiring	CTL: Cable track, size L
⑥	Z-axis cable wiring (Option)	CTM: Cable track, size M

* What ① to ⑥ indicate in the model codes on the left are explained above.

Options

Please add the option codes at the end of each stroke of the axis. When adding multiple options, put together in alphabetic order.

Name	Code	Page
AQ seal	AQ	→P13
Brake	B	→P13
Creep sensor	C	→P13
Home limit switch	L	→P14
Reverse homing specification	NM	→P14
Guide with ball-retaining mechanism	RT	→P14

Common Specifications * [] is for the high-precision specification.

Drive system	Ball screw, rolled C10 [equivalent to rolled C5]
Positioning repeatability	± 0.02 mm [± 0.01 mm]
Lost motion	0.05 mm or less [0.02 mm or less]
Guide	Integrated with base
Base	Material: Aluminum with white alumite treatment
X-axis motor output/lead	600W/40 mm
Y-axis motor output/lead	400W/40 mm

Maximum Speed by Stroke (mm/sec) (Note 3)

	300 ~ 700	900 ~ 1200	1300	1400	1500	1600	1700
X-axis	—	2400	2200	1965	1725	1530	1365
Y-axis	2400	—	—	—	—	—	—

	1800	1900	2000	2100	2200	2300	2400	2500
X-axis	1225	1110	1005	915	840	770	710	655
Y-axis	—	—	—	—	—	—	—	—

⚠ CAUTION	(Note 1)	Strokes in the model codes are in cm (centimeters).
	(Note 2)	The cable length measures from the X-axis connector box to the controller. The standard lengths are 3 m and 5 m, but other lengths can also be specified in meters up to 20 m.
	(Note 3)	Take note that the longer the stroke, the lower the maximum speed becomes.
	(Note 4)	The rated acceleration is 0.3 G. (0.3 G is the maximum acceleration.)

ICSA2[ICSPA2]-BL□H-CT(Cable Track Specification)

Dimensions (Combination direction 1)

CAD drawings can be downloaded from the website.

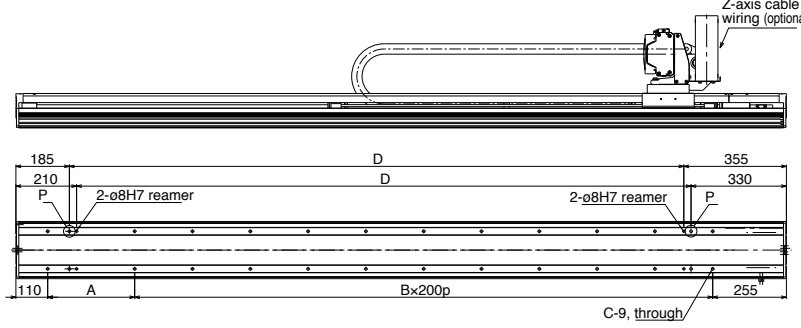
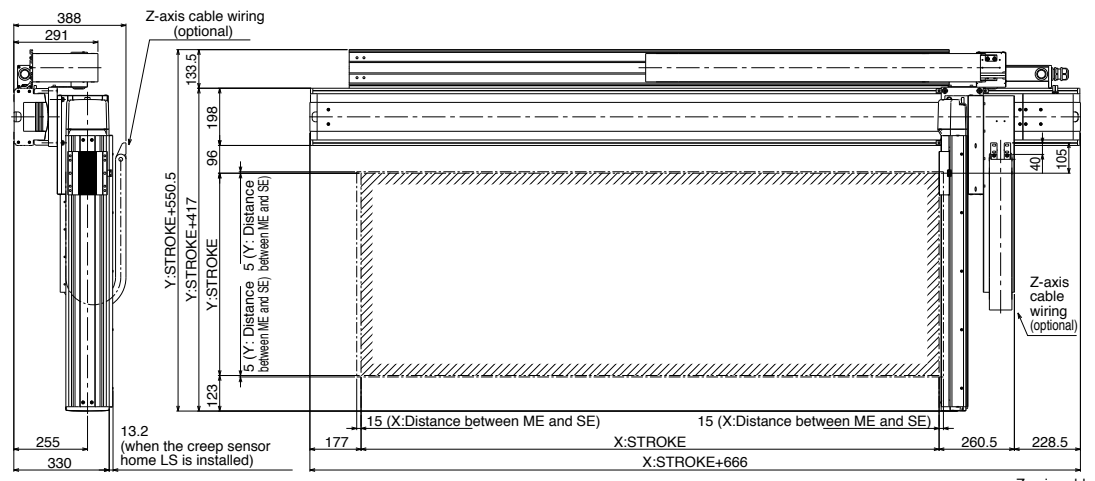
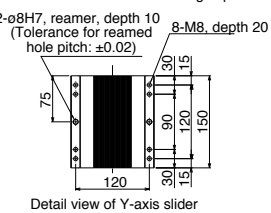
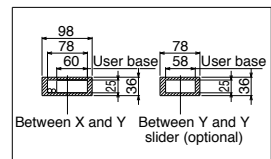
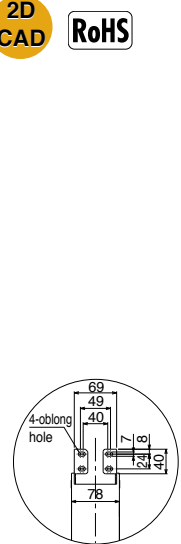

Note
Secure the moving end of the cable track for the Z-axis cable wiring to a plate, etc., installed to the Y-axis slider by the customer.

X stroke	900	950	1000	1050	1100	1150	1200	1250	1300	1350	1400	1450	1500	1550	1600	1650	1700	1750	1800	1850	1900	1950	2000	2050	2100	2150	2200	2250	2300	2350	2400	2450	2500
A	201	251	301	351	201	251	301	351	201	251	301	351	201	251	301	351	201	251	301	351	201	251	301	351	201	251	301	351	201	251	301	351	201
B	5	5	5	5	6	6	6	6	7	7	7	7	8	8	8	8	9	9	9	9	10	10	10	10	11	11	11	11	12	12	12	12	13
C	14	14	14	14	16	16	16	16	18	18	18	18	20	20	20	20	22	22	22	22	24	24	24	24	26	26	26	26	28	28	28	28	30
D	1026	1076	1126	1176	1226	1276	1326	1376	1426	1476	1526	1576	1626	1676	1726	1776	1826	1876	1926	1976	2026	2076	2126	2176	2226	2276	2326	2376	2426	2476	2526	2576	2626

ICSA2-BL□M Cartesian Robot: X-Y 2-Axes Configuration
XYB (Y-Axis Base Mount) Type

ICSPA2-BL□M Cartesian Robot: X-Y 2-Axes Configuration
XYB (Y-Axis Base Mount) Type **High-Precision Specification**

Model specification items	Series	BL□M Type	Encoder type	Axis 1 stroke	Options	Axis 2 stroke	Options	Applicable controller	Cable length	Y-axis cable wiring	Z-axis cable wiring (optional)
ICSA2: Standard 2-axis Specification ICSPA2: High-Precision 2-axis Specification	Standard	Refer to the "Models/Specifications" table below.	A: Absolute I: Incremental	90:900mm / 250:2500mm (every 100mm)	Refer to the "Options" table below.	30:300mm / 70:700mm (every 100mm)	Refer to the "Options" table below.	T1: XSEL-K T2: SCON XSEL-P/Q	3L: 3 m 5L: 5 m □L: Length specification	CTL: Cable track, size L	CTM: Cable track, size M



* Refer to page 61 for the details of model specification items.

Models/Specifications

Encoder type	XY-axis configuration direction (*)	Precision specification	Model
Absolute	1	Standard Specification	ICSA2-BL1M-A-①A3-②-③-④-⑤-⑥
		High-Precision Specification	ICSPA2-BL1M-A-①A3-②-③-④-⑤-⑥
	2	Standard Specification	ICSA2-BL2M-A-①A1-②-③-④-⑤-⑥
		High-Precision Specification	ICSPA2-BL2M-A-①A1-②-③-④-⑤-⑥
	3	Standard Specification	ICSA2-BL3M-A-①A1-②-③-④-⑤-⑥
		High-Precision Specification	ICSPA2-BL3M-A-①A3-②-③-④-⑤-⑥
	4	Standard Specification	ICSA2-BL4M-A-①A1-②-③-④-⑤-⑥
		High-Precision Specification	ICSPA2-BL4M-A-①A1-②-③-④-⑤-⑥
Incremental	1	Standard Specification	ICSA2-BL1M-I-①A3-②-③-④-⑤-⑥
		High-Precision Specification	ICSPA2-BL1M-I-①A3-②-③-④-⑤-⑥
	2	Standard Specification	ICSA2-BL2M-I-①A1-②-③-④-⑤-⑥
		High-Precision Specification	ICSPA2-BL2M-I-①A1-②-③-④-⑤-⑥
	3	Standard Specification	ICSA2-BL3M-I-①A3-②-③-④-⑤-⑥
		High-Precision Specification	ICSPA2-BL3M-I-①A3-②-③-④-⑤-⑥
	4	Standard Specification	ICSA2-BL4M-I-①A1-②-③-④-⑤-⑥
		High-Precision Specification	ICSPA2-BL4M-I-①A1-②-③-④-⑤-⑥

* Refer to the figure below for XY-axis configuration direction. Refer to the table on the right for what ① to ⑥ indicate in the above model codes.

XY Configuration Direction

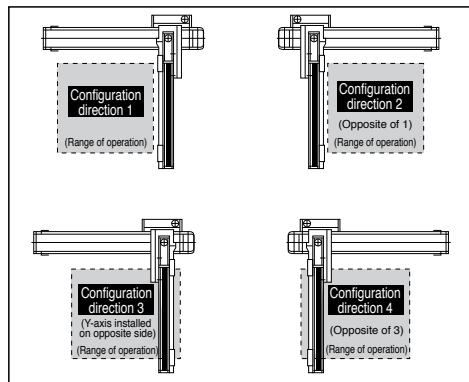

Axis Configuration * [] is for the high-precision specification.

Axis Type	Model	Page
X-axis	ISA[ISPA]-WXM-①-600-20-(stroke)-②	→P37
Y-axis	ISA[ISPA]-LYM-①-400-20-(stroke)	→P32

* ① in the above model codes indicates the encoder type which may be either A (absolute) or I (incremental).

* ② in the above model codes indicates either A1 or A3.
A1 or A3 indicates the cable exit direction for the X-axis.

A1: Specify this code for XY configuration direction 2 or 4.
A3: Specify this code for XY configuration direction 1 or 3.

Payload by Acceleration (kg) (Note 4)

Acceleration		Y-axis stroke				
		300	400	500	600	700
0.3	0.3	62.3	49.8	40.7	33.7	28.1
	0.4	—	—	—	—	—
	0.5	—	—	—	—	—
	0.6	—	—	—	—	—
	0.7	—	—	—	—	—
	0.8	—	—	—	—	—
	0.9	—	—	—	—	—
1.0	—	—	—	—	—	

Explanation of Model Code

Number	Contents	Notation
①	X-axis stroke (Note 1)	90:900 mm / 250:2500 mm
②	Y-axis stroke (Note1)	30:300 mm / 70:700 mm
③	Applicable controller	T1: XSEL-K T2: XSEL-P/Q, SCON
④	Cable length (Note 2)	3L: 3 m 5L: 5 m □L: □m
⑤	Y-axis cable wiring	CTL: Cable track, size L
⑥	Z-axis cable wiring (Option)	CTM: Cable track, size M

* What ① to ⑥ indicate in the model codes on the left are explained above.

Options

Please add the option codes at the end of each stroke of the axis. When adding multiple options, put together in alphabetic order.

Name	Code	Page
AQ seal	AQ	→P13
Brake	B	→P13
Creep sensor	C	→P13
Home limit switch	L	→P14
Reverse homing specification	NM	→P14
Guide with ball-retaining mechanism	RT	→P14

Common Specifications * [] is for the high-precision specification.

Drive system	Ball screw, rolled C10 [equivalent to rolled C5]
Positioning repeatability	± 0.02 mm [± 0.01 mm]
Lost motion	0.05 mm or less [0.02 mm or less]
Guide	Integrated with base
Base	Material: Aluminum with white alumite treatment
X-axis motor output/lead	600W/20 mm
Y-axis motor output/lead	400W/20 mm

Maximum Speed by Stroke (mm/sec) (Note 3)

	300 ~ 700	900 ~ 1200	1300	1400	1500	1600	1700
X-axis	—	1200	1100	980	860	765	680
Y-axis	1200	—	—	—	—	—	—

	1800	1900	2000	2100	2200	2300	2400	2500
X-axis	610	555	500	455	420	385	355	325
Y-axis	—	—	—	—	—	—	—	—

CAUTION

(Note 1) Strokes in the model codes are in cm (centimeters).
 (Note 2) The cable length measures from the X-axis connector box to the controller. The standard lengths are 3 m and 5 m, but other lengths can also be specified in meters up to 20 m.
 (Note 3) Take note that the longer the stroke, the lower the maximum speed becomes.
 (Note 4) The rated acceleration is 0.3 G. (0.3 G is the maximum acceleration.)

ICSA2[ICSPA2]-BL□M-CT(Cable Track Specification)

Dimensions (Combination direction 1)

CAD drawings can be downloaded from the website.

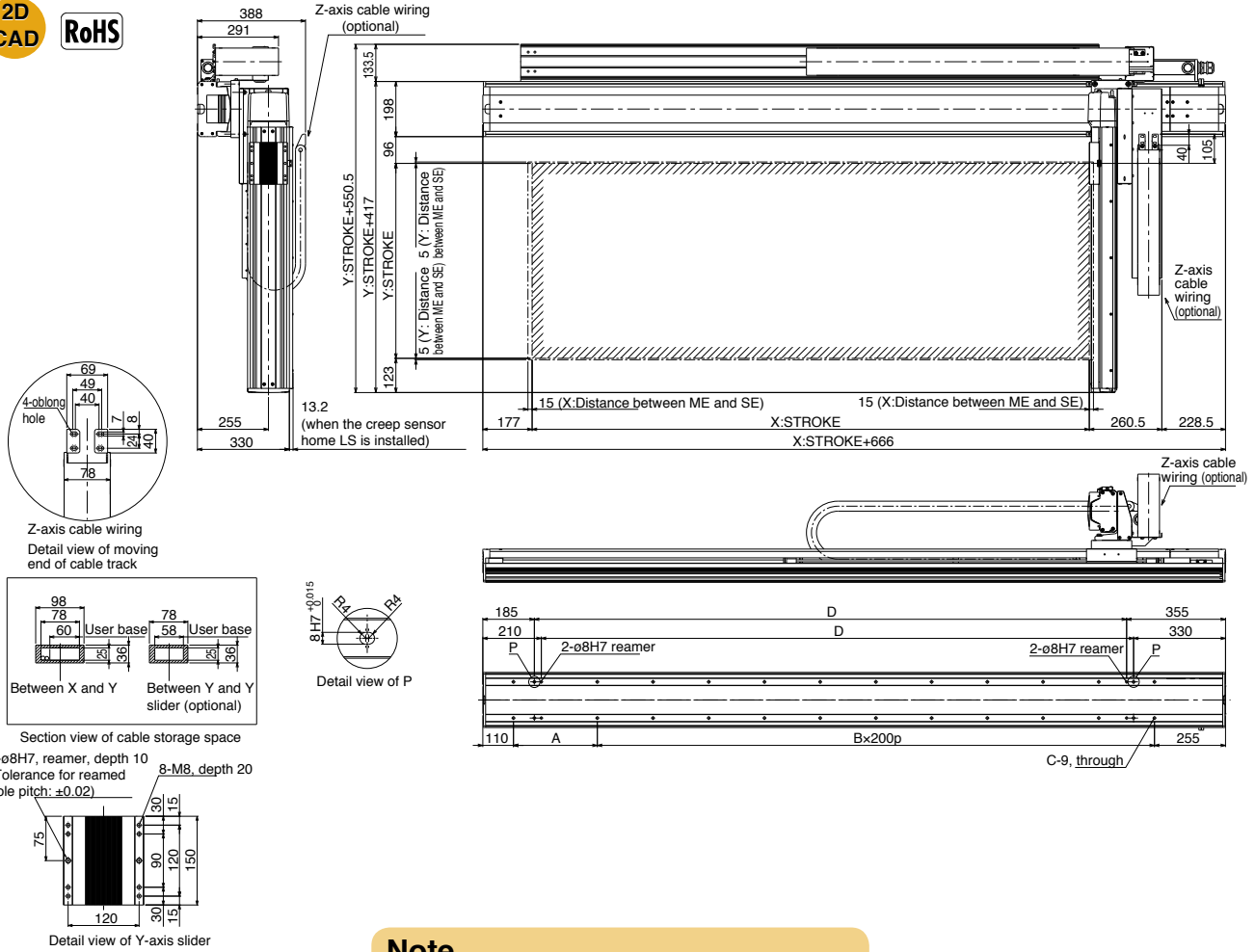

Note
Secure the moving end of the cable track for the Z-axis cable wiring to a plate, etc., installed to the Y-axis slider by the customer.

X stroke	900	950	1000	1050	1100	1150	1200	1250	1300	1350	1400	1450	1500	1550	1600	1650	1700	1750	1800	1850	1900	1950	2000	2050	2100	2150	2200	2250	2300	2350	2400	2450	2500
A	201	251	301	351	201	251	301	351	201	251	301	351	201	251	301	351	201	251	301	351	201	251	301	351	201	251	301	351	201	251	301	351	201
B	5	5	5	5	6	6	6	6	7	7	7	7	8	8	8	8	9	9	9	9	10	10	10	10	11	11	11	11	12	12	12	12	13
C	14	14	14	14	16	16	16	16	18	18	18	18	20	20	20	20	22	22	22	22	24	24	24	24	26	26	26	26	28	28	28	28	30
D	1026	1076	1126	1176	1226	1276	1326	1376	1426	1476	1526	1576	1626	1676	1726	1776	1826	1876	1926	1976	2026	2076	2126	2176	2226	2276	2326	2376	2426	2476	2526	2576	2626

ICSA2-BP□H Cartesian Robot: X-Y 2-Axes Configuration XYB (Y-Axis Base Mount) Type

ICSPA2-BP□H Cartesian Robot: X-Y 2-Axes Configuration XYB (Y-Axis Base Mount) Type High-Precision Specification

Model specification items	Series	BP□H Type	Encoder type	Axis 1 stroke	Options	Axis 2 stroke	Options	Applicable controller	Cable length	Y-axis cable wiring	Z-axis cable wiring (optional)
ICSA2: Standard 2-axis Specification ICSPA2: High-Precision 2-axis Specification	Standard	Refer to the "Models/Specifications" table below.	A: Absolute I: Incremental	30:300mm 130:1300mm (every 100mm)	Refer to the "Options" table below.	30:300mm 70:700mm (every 100mm)	Refer to the "Options" table below.	T1: XSEL-K T2: SCON XSEL-P/Q	3L: 3 m 5L: 5 m □L: Length specification	CTL: Cable track, size L	CTM: Cable track, size M



* Refer to page 61 for the details of model specification items.

Models/Specifications

Encoder type	XY-axis configuration direction (*)	Precision specification	Model
Absolute	1	Standard Specification	ICSA2-BP1H-A-①A3-②-③-④-⑤-⑥
		High-Precision Specification	ICSPA2-BP1H-A-①A3-②-③-④-⑤-⑥
	2	Standard Specification	ICSA2-BP2H-A-①A1-②-③-④-⑤-⑥
		High-Precision Specification	ICSPA2-BP2H-A-①A1-②-③-④-⑤-⑥
	3	Standard Specification	ICSA2-BP3H-A-①A3-②-③-④-⑤-⑥
		High-Precision Specification	ICSPA2-BP3H-A-①A3-②-③-④-⑤-⑥
	4	Standard Specification	ICSA2-BP4H-A-①A1-②-③-④-⑤-⑥
		High-Precision Specification	ICSPA2-BP4H-A-①A1-②-③-④-⑤-⑥
Incremental	1	Standard Specification	ICSA2-BP1H-I-①A3-②-③-④-⑤-⑥
		High-Precision Specification	ICSPA2-BP1H-I-①A3-②-③-④-⑤-⑥
	2	Standard Specification	ICSA2-BP2H-I-①A1-②-③-④-⑤-⑥
		High-Precision Specification	ICSPA2-BP2H-I-①A1-②-③-④-⑤-⑥
	3	Standard Specification	ICSA2-BP3H-I-①A3-②-③-④-⑤-⑥
		High-Precision Specification	ICSPA2-BP3H-I-①A3-②-③-④-⑤-⑥
	4	Standard Specification	ICSA2-BP4H-I-①A1-②-③-④-⑤-⑥
		High-Precision Specification	ICSPA2-BP4H-I-①A1-②-③-④-⑤-⑥

* Refer to the figure below for XY-axis configuration direction. Refer to the table on the right for what ① to ⑥ indicate in the above model codes.

XY Configuration Direction

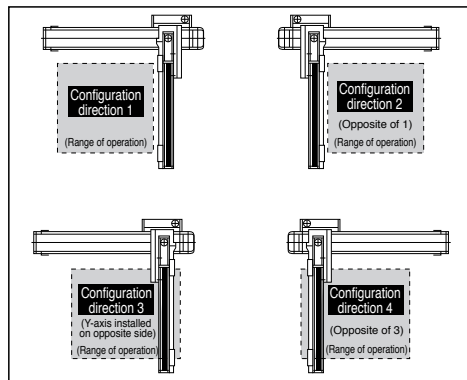

Axis Configuration

* [] is for the high-precision specification.

Axis Type	Model	Page
X-axis	ISA[ISPA]-WXM-①-750-50-(stroke)-②	→P36
Y-axis	ISA[ISPA]-LYM-①-400-40-(stroke)	→P32

* ① in the above model codes indicates the encoder type which may be either A (absolute) or I (incremental).

* ② in the above model codes indicates either A1 or A3.

A1 or A3 indicates the cable exit direction for the X-axis.

A1: Specify this code for XY configuration direction 2 or 4.

A3: Specify this code for XY configuration direction 1 or 3.

Payload by Acceleration (kg) (Note 4)

Acceleration		Y-axis stroke				
		300	400	500	600	700
0.3	0.3	31.7	30.2	28.8	27.5	26.0
	0.4	18.2	16.7	15.3	14.0	12.5
	0.5	10.1	8.6	7.2	5.9	4.4
	0.6	4.7	3.2	1.8	0.5	—
	0.7	0.2	—	—	—	—
	0.8	—	—	—	—	—
	0.9	—	—	—	—	—
1.0	—	—	—	—	—	

Explanation of Model Code

Number	Contents	Notation
①	X-axis stroke (Note 1)	30:300 mm 130:1300 mm
②	Y-axis stroke (Note1)	30:300 mm 70:700 mm
③	Applicable controller	T1: XSEL-K T2: XSEL-P/Q, SCON
④	Cable length (Note 2)	3L: 3 m 5L: 5 m □L: □m
⑤	Y-axis cable wiring	CTL: Cable track, size L
⑥	Z-axis cable wiring (Option)	CTM: Cable track, size M

* What ① to ⑥ indicate in the model codes on the left are explained above.

Options

Please add the option codes at the end of each stroke of the axis. When adding multiple options, put together in alphabetic order.

Name	Code	Page
AQ seal	AQ	→P13
Brake	B	→P13
Creep sensor	C	→P13
Home limit switch	L	→P14
Reverse homing specification	NM	→P14
Guide with ball-retaining mechanism	RT	→P14

Common Specifications * [] is for the high-precision specification.

Drive system	Ball screw, rolled C10 [equivalent to rolled C5]
Positioning repeatability	± 0.02 mm [± 0.01 mm]
Lost motion	0.05 mm or less [0.02 mm or less]
Guide	Integrated with base
Base	Material: Aluminum with white alumite treatment
X-axis motor output/lead	750W/50 mm
Y-axis motor output/lead	400W/40 mm

Maximum Speed by Stroke (mm/sec) (Note 3)

	300 ~ 700	800 ~ 1000	1100	1200	1300
X-axis	2000	1840	1570	1360	—
Y-axis	2400	—	—	—	—

CAUTION

(Note 1) Strokes in the model codes are in cm (centimeters).

(Note 2) The cable length measures from the X-axis connector box to the controller. The standard lengths are 3 m and 5 m, but other lengths can also be specified in meters up to 20 m.

(Note 3) Take note that the longer the stroke, the lower the maximum speed becomes.

(Note 4) The rated acceleration is 0.3 G. Raising the acceleration lowers the payload.

ICSA2[ICSPA2]-BP□H-CT(Cable Track Specification)

Dimensions (Combination direction 1)

CAD drawings can be downloaded from the website.

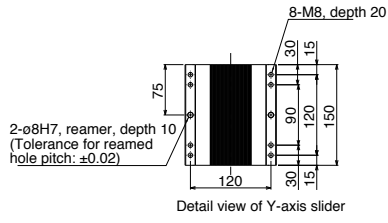
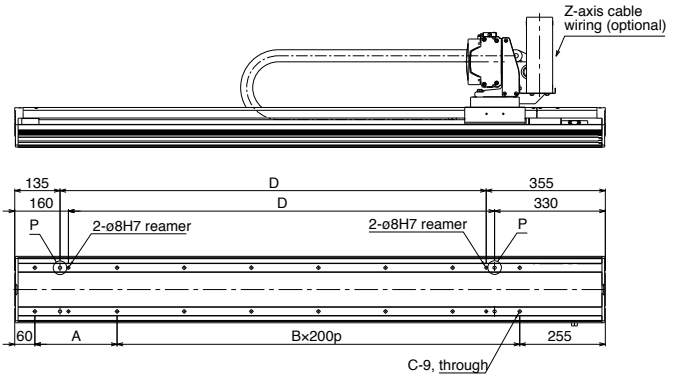
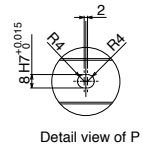
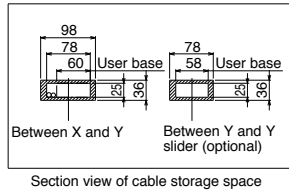
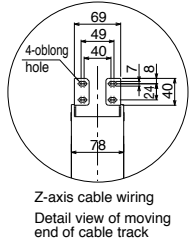
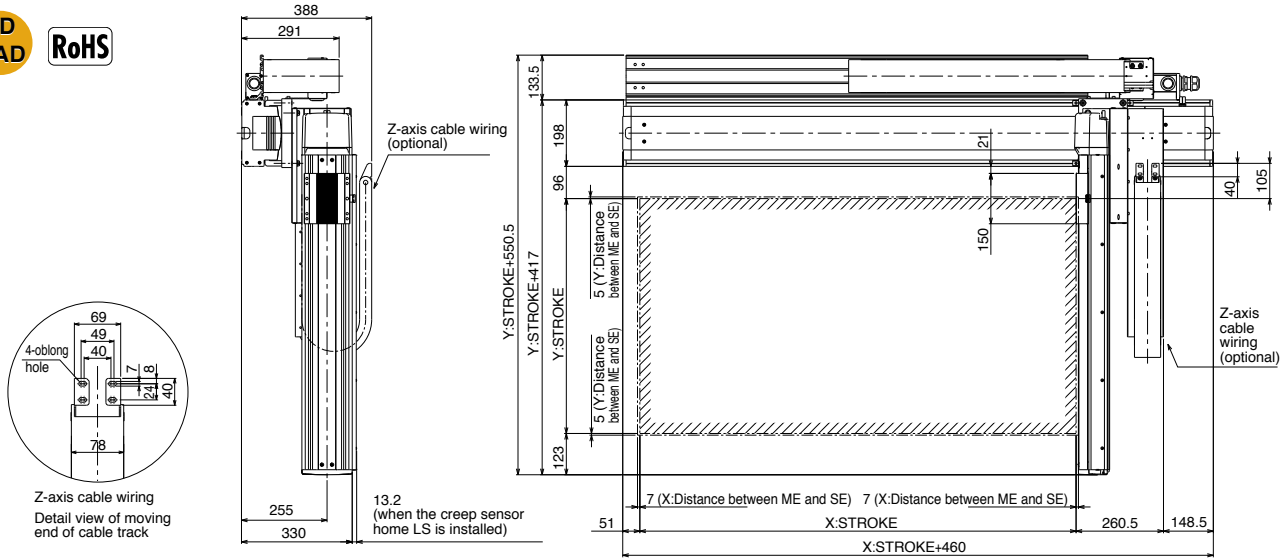

Note
Secure the moving end of the cable track for the Z-axis cable wiring to a plate, etc., installed to the Y-axis slider by the customer.

X stroke	300	350	400	450	500	550	600	650	700	750	800	850	900	950	1000	1050	1100	1150	1200	1250	1300	
A	245	295	145	195	245	295	145	195	245	295	145	195	245	295	145	195	245	295	145	195	245	
B	1	1	2	2	2	2	3	3	3	3	4	4	4	4	5	5	5	5	6	6	6	
C	6	6	8	8	8	8	10	10	10	10	12	12	12	12	14	14	14	14	14	16	16	16
D	270	320	370	420	470	520	570	620	670	720	770	820	870	920	970	1020	1070	1120	1170	1220	1270	

ICSA2-BP□M Cartesian Robot: X-Y 2-Axes Configuration
XYB (Y-Axis Base Mount) Type

ICSPA2-BP□M Cartesian Robot: X-Y 2-Axes Configuration
XYB (Y-Axis Base Mount) Type **High-Precision Specification**

Model specification items	Series	BP□M Type	Encoder type	Axis 1 stroke	Options	Axis 2 stroke	Options	Applicable controller	Cable length	Y-axis cable wiring	Z-axis cable wiring (optional)
ICSA2: Standard 2-axis Specification ICSPA2: High-Precision 2-axis Specification	Standard	Refer to the "Models/Specifications" table below.	A: Absolute I: Incremental	30:300mm 130:1300mm (every 100mm)	Refer to the "Options" table below.	30:300mm 70:700mm (every 100mm)	Refer to the "Options" table below.	T1: XSEL-K T2: SCON XSEL-P/Q	3L: 3 m 5L: 5 m □L: Length specification	CTL: Cable track, size L	CTM: Cable track, size M



* Refer to page 61 for the details of model specification items.

Models/Specifications

Encoder type	XY-axis configuration direction (*)	Precision specification	Model
Absolute	1	Standard Specification	ICSA2-BP1M-A-①A3-②-③-④-⑤-⑥
		High-Precision Specification	ICSPA2-BP1M-A-①A3-②-③-④-⑤-⑥
	2	Standard Specification	ICSA2-BP2M-A-①A1-②-③-④-⑤-⑥
		High-Precision Specification	ICSPA2-BP2M-A-①A1-②-③-④-⑤-⑥
	3	Standard Specification	ICSA2-BP3M-A-①A3-②-③-④-⑤-⑥
		High-Precision Specification	ICSPA2-BP3M-A-①A3-②-③-④-⑤-⑥
	4	Standard Specification	ICSA2-BP4M-A-①A1-②-③-④-⑤-⑥
		High-Precision Specification	ICSPA2-BP4M-A-①A1-②-③-④-⑤-⑥
Incremental	1	Standard Specification	ICSA2-BP1M-I-①A3-②-③-④-⑤-⑥
		High-Precision Specification	ICSPA2-BP1M-I-①A3-②-③-④-⑤-⑥
	2	Standard Specification	ICSA2-BP2M-I-①A1-②-③-④-⑤-⑥
		High-Precision Specification	ICSPA2-BP2M-I-①A1-②-③-④-⑤-⑥
	3	Standard Specification	ICSA2-BP3M-I-①A3-②-③-④-⑤-⑥
		High-Precision Specification	ICSPA2-BP3M-I-①A3-②-③-④-⑤-⑥
	4	Standard Specification	ICSA2-BP4M-I-①A1-②-③-④-⑤-⑥
		High-Precision Specification	ICSPA2-BP4M-I-①A1-②-③-④-⑤-⑥

* Refer to the figure below for XY-axis configuration direction. Refer to the table on the right for what ① to ⑥ indicate in the above model codes.

XY Configuration Direction

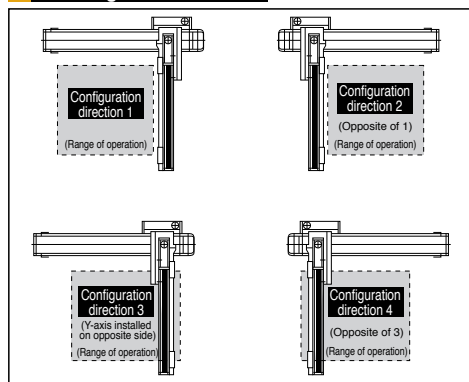

Axis Configuration * [] is for the high-precision specification.

Axis Type	Model	Page
X-axis	ISA[ISPA]-WXM-①-750-25-(stroke)-②	→P36
Y-axis	ISA[ISPA]-LYM-①-400-20-(stroke)	→P32

* ① in the above model codes indicates the encoder type which may be either A (absolute) or I (incremental).

* ② in the above model codes indicates either A1 or A3.
A1 or A3 indicates the cable exit direction for the X-axis.

A1: Specify this code for XY configuration direction 2 or 4.
A3: Specify this code for XY configuration direction 1 or 3.

Payload by Acceleration (kg) (Note 4)

Acceleration		Y-axis stroke				
		300	400	500	600	700
0.3	0.3	62.3	49.8	40.7	33.7	28.1
	0.4	54.5	49.8	40.7	33.7	28.1
	0.5	42.5	41.0	39.6	33.7	28.1
	0.6	31.7	30.2	28.8	27.5	26.0
	0.7	24.5	23.0	21.6	20.3	18.8
	0.8	18.2	16.7	15.3	14.0	12.5
	0.9	13.7	12.2	10.8	9.5	8.0
1.0	10.1	8.6	7.2	5.9	4.4	

Explanation of Model Code

Number	Contents	Notation
①	X-axis stroke (Note 1)	30:300 mm 130:1300 mm
②	Y-axis stroke (Note1)	30:300 mm 70:700 mm
③	Applicable controller	T1: XSEL-K T2: XSEL-P/Q, SCON
④	Cable length (Note 2)	3L: 3 m 5L: 5 m □L: □m
⑤	Y-axis cable wiring	CTL: Cable track, size L
⑥	Z-axis cable wiring (Option)	CTM: Cable track, size M

* What ① to ⑥ indicate in the model codes on the left are explained above.

Options

Please add the option codes at the end of each stroke of the axis. When adding multiple options, put together in alphabetic order.

Name	Code	Page
AQ seal	AQ	→P13
Brake	B	→P13
Creep sensor	C	→P13
Home limit switch	L	→P14
Reverse homing specification	NM	→P14
Guide with ball-retaining mechanism	RT	→P14

Common Specifications * [] is for the high-precision specification.

Drive system	Ball screw, rolled C10 [equivalent to rolled C5]
Positioning repeatability	± 0.02 mm [± 0.01 mm]
Lost motion	0.05 mm or less [0.02 mm or less]
Guide	Integrated with base
Base	Material: Aluminum with white alumite treatment
X-axis motor output/lead	750W/25 mm
Y-axis motor output/lead	400W/20 mm

Maximum Speed by Stroke (mm/sec) (Note 3)

	300 ~ 700	800 ~ 900	1000	1100	1200	1300
X-axis	1250	1090	920	785	680	
Y-axis	1200	—	—	—	—	—

CAUTION

(Note 1) Strokes in the model codes are in cm (centimeters).
 (Note 2) The cable length measures from the X-axis connector box to the controller. The standard lengths are 3 m and 5 m, but other lengths can also be specified in meters up to 20 m.
 (Note 3) Take note that the longer the stroke, the lower the maximum speed becomes.
 (Note 4) The rated acceleration is 0.3 G. Raising the acceleration lowers the payload.

ICSA2[ICSPA2]-BP□M-CT(Cable Track Specification)

Dimensions (Combination direction 1)

CAD drawings can be downloaded from the website.

2D CAD RoHS

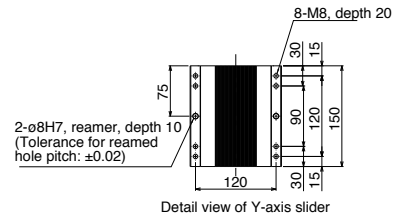
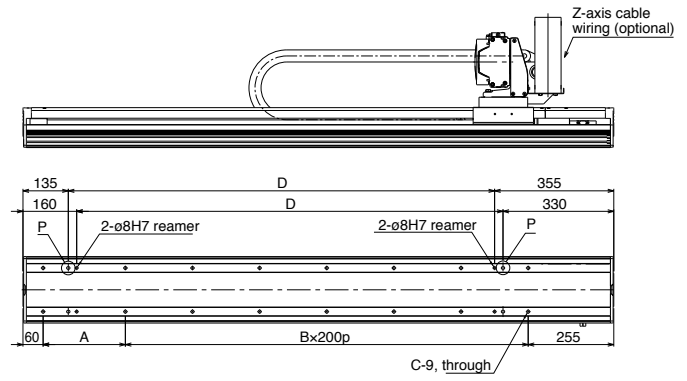
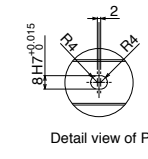
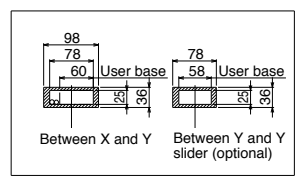
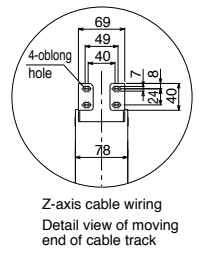
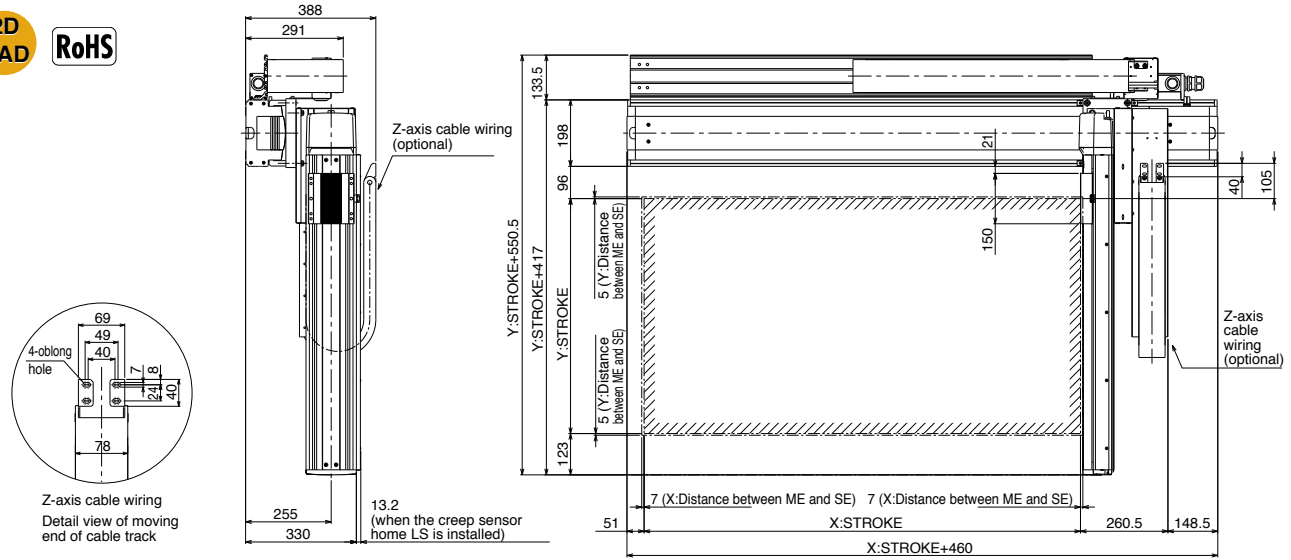

Note
Secure the moving end of the cable track for the Z-axis cable wiring to a plate, etc., installed to the Y-axis slider by the customer.

X stroke	300	350	400	450	500	550	600	650	700	750	800	850	900	950	1000	1050	1100	1150	1200	1250	1300
A	245	295	145	195	245	295	145	195	245	295	145	195	245	295	145	195	245	295	145	195	245
B	1	1	2	2	2	2	3	3	3	3	4	4	4	4	5	5	5	5	6	6	6
C	6	6	8	8	8	8	10	10	10	10	12	12	12	12	14	14	14	14	16	16	16
D	270	320	370	420	470	520	570	620	670	720	770	820	870	920	970	1020	1070	1120	1170	1220	1270

ICSA2-BQ□H Cartesian Robot: X-Y 2-Axes Configuration
XYB (Y-Axis Base Mount) Type

ICSPA2-BQ□H Cartesian Robot: X-Y 2-Axes Configuration
XYB (Y-Axis Base Mount) Type **High-Precision Specification**

Model specification items	Series	BQ□H Type	Encoder type	Axis 1 stroke	Options	Axis 2 stroke	Options	Applicable controller	Cable length	Y-axis cable wiring	Z-axis cable wiring (optional)
ICSA2: Standard 2-axis Specification ICSPA2: High-Precision 2-axis Specification	Standard	Refer to the "Models/Specifications" table below.	A: Absolute I: Incremental	90:900mm 250:2500mm (every 100mm)	Refer to the "Options" table below.	30:300mm 70:700mm (every 100mm)	Refer to the "Options" table below.	T1: XSEL-K T2: SCON XSEL-P/Q	3L: 3 m 5L: 5 m □L: Length specification	CTL: Cable track, size L	CTM: Cable track, size M



* Refer to page 61 for the details of model specification items.

Models/Specifications

Encoder type	XY-axis configuration direction (*)	Precision specification	Model
Absolute	1	Standard Specification	ICSA2-BQ1H-A-①A3-②-③-④-⑤-⑥
		High-Precision Specification	ICSPA2-BQ1H-A-①A3-②-③-④-⑤-⑥
	2	Standard Specification	ICSA2-BQ2H-A-①A1-②-③-④-⑤-⑥
		High-Precision Specification	ICSPA2-BQ2H-A-①A1-②-③-④-⑤-⑥
	3	Standard Specification	ICSA2-BQ3H-A-①A3-②-③-④-⑤-⑥
		High-Precision Specification	ICSPA2-BQ3H-A-①A3-②-③-④-⑤-⑥
	4	Standard Specification	ICSA2-BQ4H-A-①A1-②-③-④-⑤-⑥
		High-Precision Specification	ICSPA2-BQ4H-A-①A1-②-③-④-⑤-⑥
Incremental	1	Standard Specification	ICSA2-BQ1H-I-①A3-②-③-④-⑤-⑥
		High-Precision Specification	ICSPA2-BQ1H-I-①A3-②-③-④-⑤-⑥
	2	Standard Specification	ICSA2-BQ2H-I-①A1-②-③-④-⑤-⑥
		High-Precision Specification	ICSPA2-BQ2H-I-①A1-②-③-④-⑤-⑥
	3	Standard Specification	ICSA2-BQ3H-I-①A3-②-③-④-⑤-⑥
		High-Precision Specification	ICSPA2-BQ3H-I-①A3-②-③-④-⑤-⑥
	4	Standard Specification	ICSA2-BQ4H-I-①A1-②-③-④-⑤-⑥
		High-Precision Specification	ICSPA2-BQ4H-I-①A1-②-③-④-⑤-⑥

* Refer to the figure below for XY-axis configuration direction. Refer to the table on the right for what ① to ⑥ indicate in the above model codes.

XY Configuration Direction

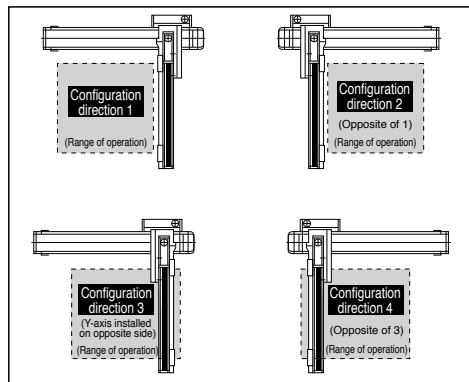

Axis Configuration * [] is for the high-precision specification.

Axis Type	Model	Page
X-axis	ISA[ISPA]-WXM-①-750-50-(stroke)-②	→P38
Y-axis	ISA[ISPA]-LYM-①-400-40-(stroke)	→P32

* ① in the above model codes indicates the encoder type which may be either A (absolute) or I (incremental).

* ② in the above model codes indicates either A1 or A3.
A1 or A3 indicates the cable exit direction for the X-axis.

A1: Specify this code for XY configuration direction 2 or 4.
A3: Specify this code for XY configuration direction 1 or 3.

Payload by Acceleration (kg) (Note 4)

Acceleration		Y-axis stroke				
		300	400	500	600	700
0.3	0.3	31.7	30.2	28.8	27.5	26.0
	0.4	—	—	—	—	—
	0.5	—	—	—	—	—
	0.6	—	—	—	—	—
	0.7	—	—	—	—	—
	0.8	—	—	—	—	—
	0.9	—	—	—	—	—
1.0	—	—	—	—	—	

Explanation of Model Code

Number	Contents	Notation
①	X-axis stroke (Note 1)	90:900 mm 250:2500 mm
②	Y-axis stroke (Note1)	30:300 mm 70:700 mm
③	Applicable controller	T1: XSEL-K T2: XSEL-P/Q, SCON
④	Cable length (Note 2)	3L: 3 m 5L: 5 m □L: □m
⑤	Y-axis cable wiring	CTL: Cable track, size L
⑥	Z-axis cable wiring (Option)	CTM: Cable track, size M

* What ① to ⑥ indicate in the model codes on the left are explained above.

Options

Please add the option codes at the end of each stroke of the axis. When adding multiple options, put together in alphabetic order.

Name	Code	Page
AQ seal	AQ	→P13
Brake	B	→P13
Creep sensor	C	→P13
Home limit switch	L	→P14
Reverse homing specification	NM	→P14
Guide with ball-retaining mechanism	RT	→P14

Common Specifications * [] is for the high-precision specification.

Drive system	Ball screw, rolled C10 [equivalent to rolled C5]
Positioning repeatability	± 0.02 mm [± 0.01 mm]
Lost motion	0.05 mm or less [0.02 mm or less]
Guide	Integrated with base
Base	Material: Aluminum with white alumite treatment
X-axis motor output/lead	750W/50 mm
Y-axis motor output/lead	400W/40 mm

Maximum Speed by Stroke (mm/sec) (Note 3)

	300 ~ 700	900 ~ 1700	1800	1900	2000	2100	2200	2300	2400	2500
X-axis	—	2000	1930	1740	1580	1440	1320	1210	1115	1035
Y-axis	2400	—	—	—	—	—	—	—	—	—

CAUTION

(Note 1) Strokes in the model codes are in cm (centimeters).
 (Note 2) The cable length measures from the X-axis connector box to the controller. The standard lengths are 3 m and 5 m, but other lengths can also be specified in meters up to 20 m.
 (Note 3) Take note that the longer the stroke, the lower the maximum speed becomes.
 (Note 4) The rated acceleration is 0.3 G. (0.3 G is the maximum acceleration.)

ICSA2[ICSPA2]-BQ□H-CT(Cable Track Specification)

Dimensions (Combination direction 1)

CAD drawings can be downloaded from the website.

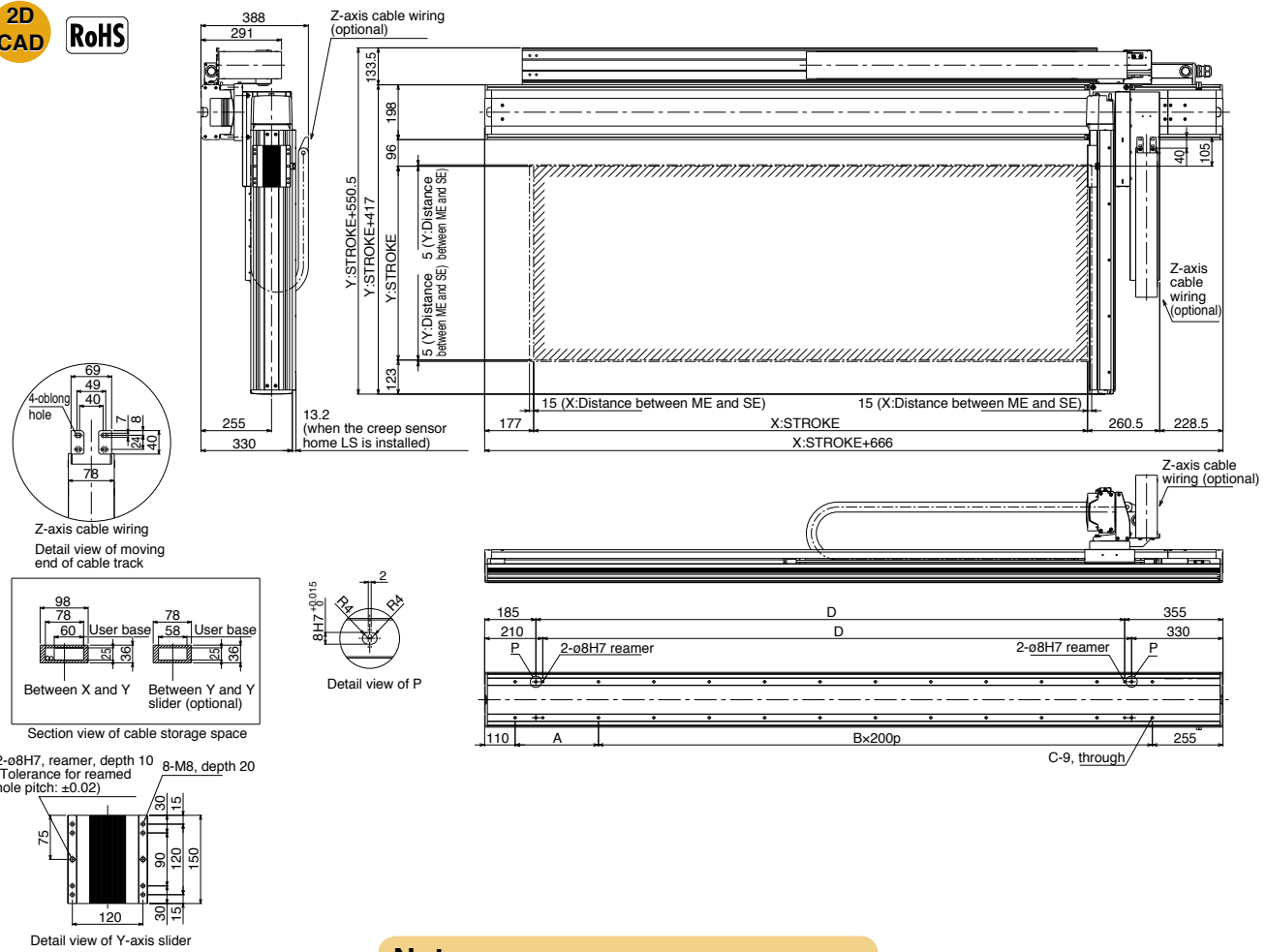

Note
Secure the moving end of the cable track for the Z-axis cable wiring to a plate, etc., installed to the Y-axis slider by the customer.

X stroke	900	950	1000	1050	1100	1150	1200	1250	1300	1350	1400	1450	1500	1550	1600	1650	1700	1750	1800	1850	1900	1950	2000	2050	2100	2150	2200	2250	2300	2350	2400	2450	2500
A	201	251	301	351	201	251	301	351	201	251	301	351	201	251	301	351	201	251	301	351	201	251	301	351	201	251	301	351	201	251	301	351	201
B	5	5	5	5	6	6	6	6	7	7	7	7	8	8	8	8	9	9	9	9	10	10	10	10	11	11	11	11	12	12	12	12	13
C	14	14	14	14	16	16	16	16	18	18	18	18	20	20	20	20	22	22	22	22	24	24	24	24	26	26	26	26	28	28	28	28	30
D	1026	1076	1126	1176	1226	1276	1326	1376	1426	1476	1526	1576	1626	1676	1726	1776	1826	1876	1926	1976	2026	2076	2126	2176	2226	2276	2326	2376	2426	2476	2526	2576	2626

ICSA2-BQ□M Cartesian Robot: X-Y 2-Axes Configuration
XYB (Y-Axis Base Mount) Type

ICSPA2-BQ□M Cartesian Robot: X-Y 2-Axes Configuration
XYB (Y-Axis Base Mount) Type **High-Precision Specification**

Model specification items	Series	BQ□M Type	Encoder type	Axis 1 stroke	Options	Axis 2 stroke	Options	Applicable controller	Cable length	Y-axis cable wiring	Z-axis cable wiring (optional)
ICSA2: Standard 2-axis Specification ICSPA2: High-Precision 2-axis Specification	Standard	Refer to the "Models/Specifications" table below.	A: Absolute I: Incremental	90:900mm / 250:2500mm (every 100mm)	Refer to the "Options" table below.	30:300mm / 70:700mm (every 100mm)	Refer to the "Options" table below.	T1: XSEL-K T2: SCON XSEL-P/Q	3L: 3 m 5L: 5 m □L: Length specification	CTL: Cable track, size L	CTM: Cable track, size M



* Refer to page 61 for the details of model specification items.

Models/Specifications

Encoder type	XY-axis configuration direction (*)	Precision specification	Model
Absolute	1	Standard Specification	ICSA2-BQ1M-A-①A3-②-③-④-⑤-⑥
		High-Precision Specification	ICSPA2-BQ1M-A-①A3-②-③-④-⑤-⑥
	2	Standard Specification	ICSA2-BQ2M-A-①A1-②-③-④-⑤-⑥
		High-Precision Specification	ICSPA2-BQ2M-A-①A1-②-③-④-⑤-⑥
	3	Standard Specification	ICSA2-BQ3M-A-①A3-②-③-④-⑤-⑥
		High-Precision Specification	ICSPA2-BQ3M-A-①A3-②-③-④-⑤-⑥
	4	Standard Specification	ICSA2-BQ4M-A-①A1-②-③-④-⑤-⑥
		High-Precision Specification	ICSPA2-BQ4M-A-①A1-②-③-④-⑤-⑥
Incremental	1	Standard Specification	ICSA2-BQ1M-I-①A3-②-③-④-⑤-⑥
		High-Precision Specification	ICSPA2-BQ1M-I-①A3-②-③-④-⑤-⑥
	2	Standard Specification	ICSA2-BQ2M-I-①A1-②-③-④-⑤-⑥
		High-Precision Specification	ICSPA2-BQ2M-I-①A1-②-③-④-⑤-⑥
	3	Standard Specification	ICSA2-BQ3M-I-①A3-②-③-④-⑤-⑥
		High-Precision Specification	ICSPA2-BQ3M-I-①A3-②-③-④-⑤-⑥
	4	Standard Specification	ICSA2-BQ4M-I-①A1-②-③-④-⑤-⑥
		High-Precision Specification	ICSPA2-BQ4M-I-①A1-②-③-④-⑤-⑥

* Refer to the figure below for XY-axis configuration direction. Refer to the table on the right for what ① to ⑥ indicate in the above model codes.

XY Configuration Direction

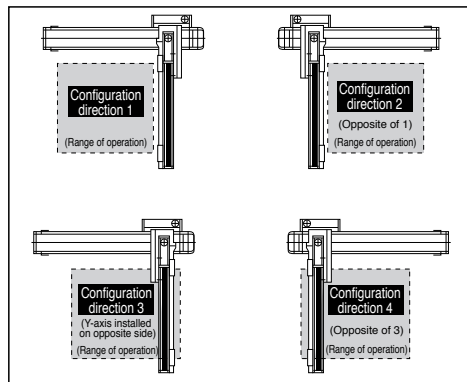

Axis Configuration * [] is for the high-precision specification.

Axis Type	Model	Page
X-axis	ISA[ISPA]-WXM-①-750-25-(stroke)-②	→P38
Y-axis	ISA[ISPA]-LYM-①-400-20-(stroke)	→P32

* ① in the above model codes indicates the encoder type which may be either A (absolute) or I (incremental).

* ② in the above model codes indicates either A1 or A3.
A1 or A3 indicates the cable exit direction for the X-axis.

A1: Specify this code for XY configuration direction 2 or 4.
A3: Specify this code for XY configuration direction 1 or 3.

Payload by Acceleration (kg) (Note 4)

Acceleration	Y-axis stroke	Y-axis stroke				
		300	400	500	600	700
0.3	62.3	49.8	40.7	33.7	28.1	
0.4	—	—	—	—	—	
0.5	—	—	—	—	—	
0.6	—	—	—	—	—	
0.7	—	—	—	—	—	
0.8	—	—	—	—	—	
0.9	—	—	—	—	—	
1.0	—	—	—	—	—	

Explanation of Model Code

Number	Contents	Notation
①	X-axis stroke (Note 1)	90:900 mm / 250:2500 mm
②	Y-axis stroke (Note1)	30:300 mm / 70:700 mm
③	Applicable controller	T1: XSEL-K T2: XSEL-P/Q, SCON
④	Cable length (Note 2)	3L: 3 m 5L: 5 m □L: □m
⑤	Y-axis cable wiring	CTL: Cable track, size L
⑥	Z-axis cable wiring (Option)	CTM: Cable track, size M

* What ① to ⑥ indicate in the model codes on the left are explained above.

Options

Please add the option codes at the end of each stroke of the axis. When adding multiple options, put together in alphabetic order.

Name	Code	Page
AQ seal	AQ	→P13
Brake	B	→P13
Creep sensor	C	→P13
Home limit switch	L	→P14
Reverse homing specification	NM	→P14
Guide with ball-retaining mechanism	RT	→P14

Common Specifications * [] is for the high-precision specification.

Drive system	Ball screw, rolled C10 [equivalent to rolled C5]
Positioning repeatability	± 0.02 mm [± 0.01 mm]
Lost motion	0.05 mm or less [0.02 mm or less]
Guide	Integrated with base
Base	Material: Aluminum with white alumite treatment
X-axis motor output/lead	750W/25 mm
Y-axis motor output/lead	400W/20 mm

Maximum Speed by Stroke (mm/sec) (Note 3)

	300 ~ 700	900 ~ 1500	1600	1700	1800	1900
X-axis	—	1250	1200	1075	965	870
Y-axis	1200	—	—	—	—	—

	2000	2100	2200	2300	2400	2500
X-axis	790	720	660	605	555	515
Y-axis	—	—	—	—	—	—

CAUTION

(Note 1) Strokes in the model codes are in cm (centimeters).
 (Note 2) The cable length measures from the X-axis connector box to the controller. The standard lengths are 3 m and 5 m, but other lengths can also be specified in meters up to 20 m.
 (Note 3) Take note that the longer the stroke, the lower the maximum speed becomes.
 (Note 4) The rated acceleration is 0.3 G. (0.3 G is the maximum acceleration.)

ICSA2[ICSPA2]-BQ□M-CT(Cable Track Specification)

Dimensions (Combination direction 1)

CAD drawings can be downloaded from the website.

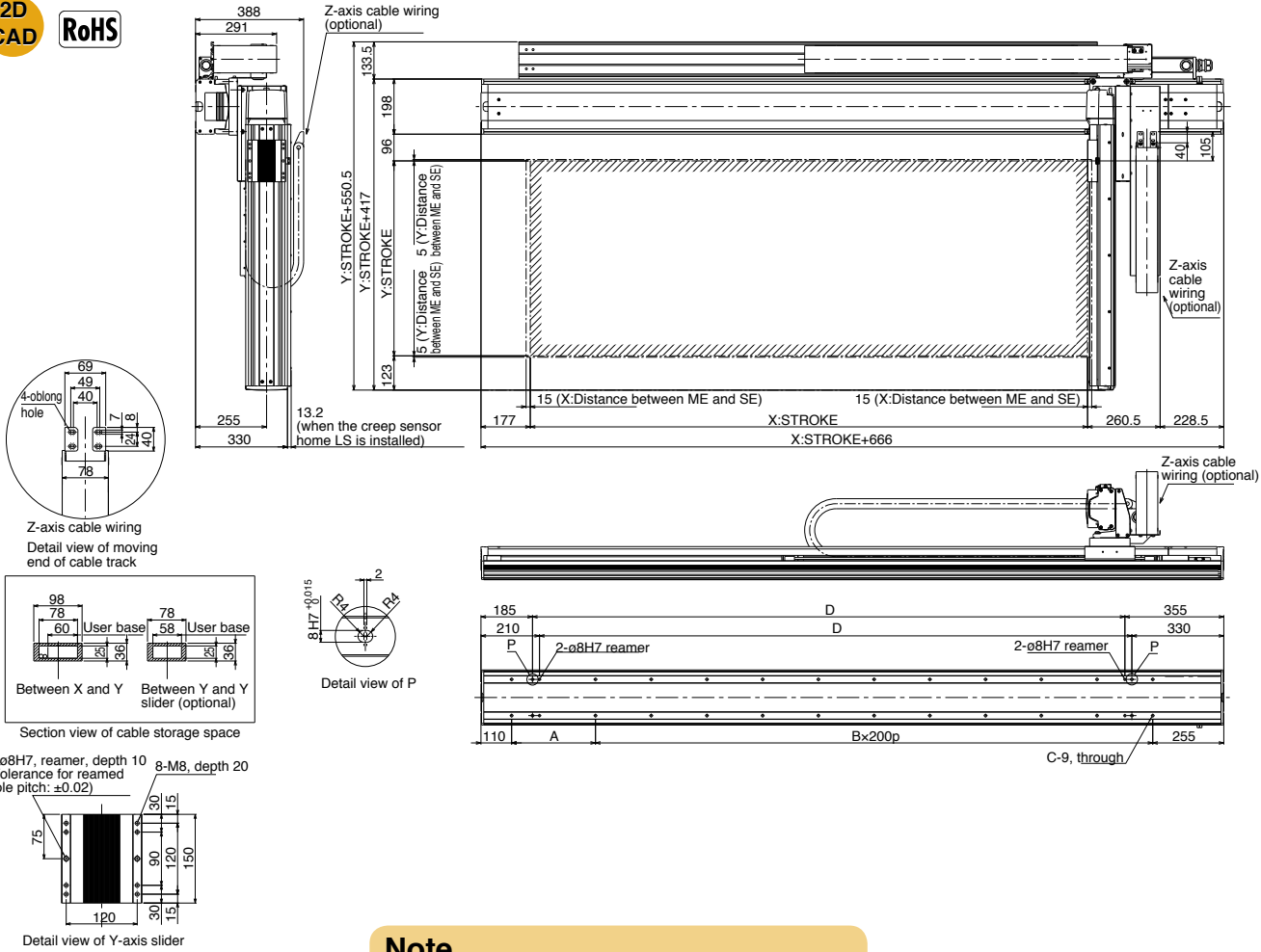

Note
Secure the moving end of the cable track for the Z-axis cable wiring to a plate, etc., installed to the Y-axis slider by the customer.

X stroke	900	950	1000	1050	1100	1150	1200	1250	1300	1350	1400	1450	1500	1550	1600	1650	1700	1750	1800	1850	1900	1950	2000	2050	2100	2150	2200	2250	2300	2350	2400	2450	2500
A	201	251	301	351	201	251	301	351	201	251	301	351	201	251	301	351	201	251	301	351	201	251	301	351	201	251	301	351	201	251	301	351	201
B	5	5	5	5	6	6	6	6	7	7	7	7	8	8	8	8	9	9	9	9	10	10	10	10	11	11	11	11	12	12	12	12	13
C	14	14	14	14	16	16	16	16	18	18	18	18	20	20	20	20	22	22	22	22	24	24	24	24	26	26	26	26	28	28	28	28	30
D	1026	1076	1126	1176	1226	1276	1326	1376	1426	1476	1526	1576	1626	1676	1726	1776	1826	1876	1926	1976	2026	2076	2126	2176	2226	2276	2326	2376	2426	2476	2526	2576	2626

ICSA2-SA□H Cartesian Robot: X-Y 2-Axes Configuration, XYS (Y-Axis Slider Mount) Type
ICSPA2-SA□H Cartesian Robot: X-Y 2-Axes Configuration, XYS (Y-Axis Slider Mount) Type **High-Precision Specification**

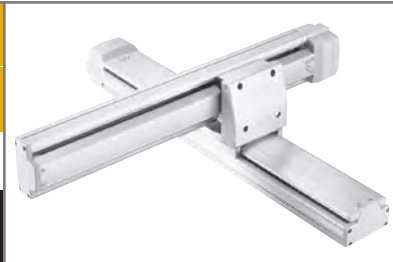

Type: XYS type Stroke: X-axis: 100-600mm Y-axis: 100-400mm Load capacity: 6.2kg ~ 4.1kg

Model specification items: ICSA2 - SA1H - A - 60AQLNM - 40AQL - T1 - 5L - SC

* Refer to page 61 for the details of model specification items.

Models/Specifications

Model	Axis configuration		Encoder type	Motor output (W)	Lead (mm)	Stroke (mm) In increments of 100mm	Speed (mm/s)	Load capacity (Note 1)	Positioning repeatability (mm) (Note 2)
ICSA2 [ICSPA2] -SA□H-A-***-***-T1-△-SC	X-axis	ISA [ISPA] -SXM-A-60-16-***-T1	Absolute	60	16	100 ~ 600	1 ~ 800	6.2 ~ 4.1	±0.02
	Y-axis	ISA [ISPA] -SYM-A-60-16-***-T1				100 ~ 400			
ICSA2 [ICSPA2] -SA□H-I-***-***-T1-△-SC	X-axis	ISA [ISPA] -SXM-I-60-16-***-T1	Incremental			100 ~ 600			
	Y-axis	ISA [ISPA] -SYM-I-60-16-***-T1				100 ~ 400			

* In the above model names, □ indicates the configuration direction, *** the stroke/applicable options (stroke is specified in centimeters), △ the cable length.

Options

Name	Code	Page	Remarks
AQ seal	AQ	P13	
Brake	B	P13	
Creep sensor	C	P13	
Home limit switch	L	P14	
Reverse homing specification	NM	P14	
Guide with ball-retaining mechanism	RT	P14	

Common Specifications

Drive system (Note 4)	Ball screw, rolled C10 [equivalent to rolled C5]
Backlash (Note 5)	0.05mm or less [0.02mm or less]
Guide	Integrated with base
Base	Material: Aluminum with white alumite treatment
Cable length (Note 6)	3L: 3m, 5L: 5m, □L: Length specification
Cable management	SC: Self-standing cable

Load Capacity by Acceleration (kg)

Acceleration (G)	Y-axis stroke (mm)			
	100	200	300	400
0.3	6.2	5.5	4.8	4.1
0.4	3.2	2.5	1.8	1.1
0.5	1.2	0.5		
0.6	0.2			
0.7				
0.8				
0.9				
1.0				

Maximum Speed by Stroke (mm/sec)

Axis	Stroke (mm)	
	100 ~ 400	500 ~ 600
X-axis	800	
Y-axis	800	-

Configuration direction

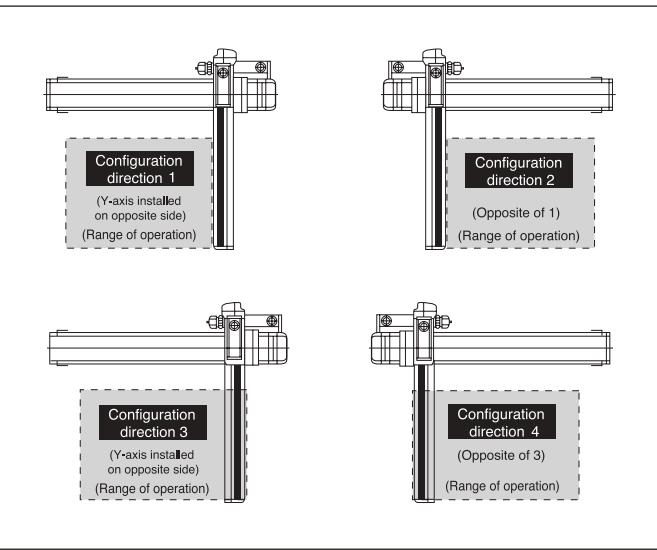

Applicable Controller Specifications

Applicable controller	Controller type	Model	Page
X-SEL	General-purpose type	XSEL-K-2-60□-60□-□-□□□-□-□	
	Compact type	XSEL-J-2-60□-60□-□-□□□-□-□	

Caution
 (Note 1) The load capacity assumes operation at the rated acceleration (0.3 G). The actuator can be operated at accelerations beyond the rated acceleration, but the load capacity will decrease (refer to the table of load capacity by acceleration).
 (Notes 2, 3, 4) The figures in brackets apply to the ICSPA2.
 (Note 5) The cable length measures from the X-axis connector box to the controller. The standard lengths are 3 m and 5 m, but other lengths can also be specified in meters up to 20 m (e.g., 10L = 10 m).

* Refer to page 59 for other points to note.

Self-standing Cable Specification (Cable Management Code: SC)

Single-Axis Robots
Cartesian Robots

Dimensions

* Note that changing the home direction will require the actuator to be returned to IAI for adjustment.

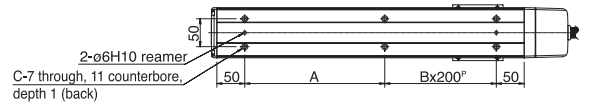
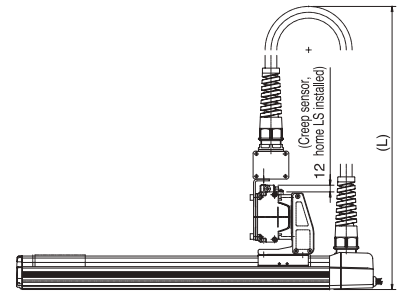
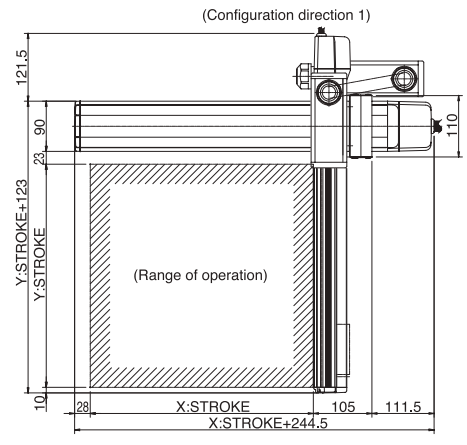
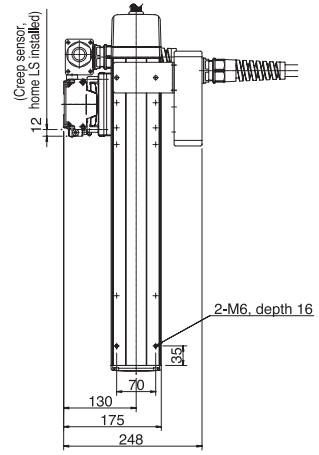

		Dimension □					
Yst	Xst	100	200	300	400	500	600
100		480	530	580	630	680	□30
200		530	580	630	680	□30	□80
300		580	630	680	□30	□80	830
400		630	680	□30	□80	830	880

X stroke	100	200	300	400	500	600
A	151	251	151	251	151	251
B	0	0	1	1	2	2
C	4	4	6	6	8	8

* Note that changing the home direction will require the actuator to be returned to IAI for adjustment.

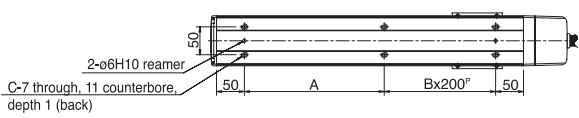
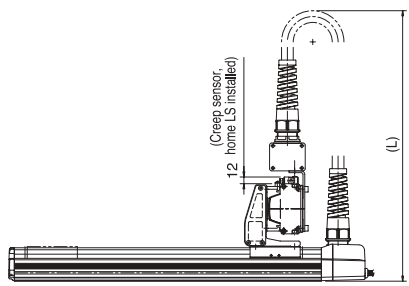
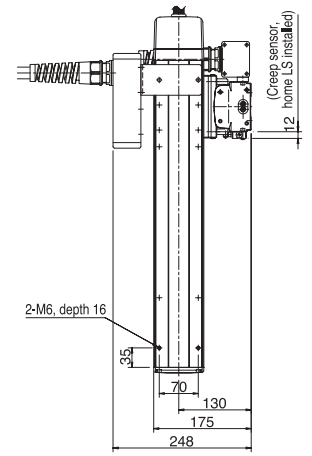
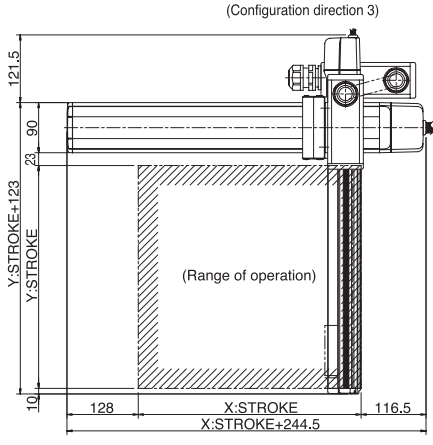

		Dimension □					
Yst	Xst	100	200	300	400	500	600
100		480	530	580	630	680	□30
200		530	580	630	680	□30	□80
300		580	630	680	□30	□80	830
400		630	680	□30	□80	830	880

X stroke	100	200	300	400	500	600
A	151	251	151	251	151	251
B	0	0	1	1	2	2
C	4	4	6	6	8	8

ICSA2-SA□M Cartesian Robot: X-Y 2-Axes Configuration, XYS (Y-Axis Slider Mount) Type

ICSPA2-SA□M Cartesian Robot: X-Y 2-Axes Configuration, XYS (Y-Axis Slider Mount) Type **High-Precision Specification**

Type **XYS type** Stroke X-axis: 100~600mm Y-axis: 100~400mm Load capacity 19.2kg ~ 6.4kg

Model specification items Series Type Encoder type X-axis stroke + options Y-axis stroke + options Applicable controller Cable length Cable management
ICSA2 - SA1M - A - 60AQLNM - 40AQL - T1 - 5L - SC

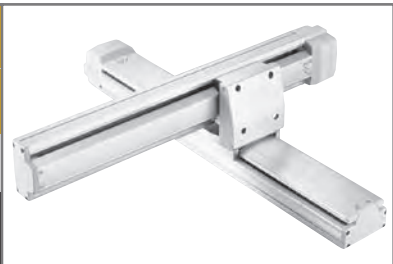

* Refer to page 61 for the details of model specification items.

Models/Specifications

Model	Axis configuration		Encoder type	Motor output (W)	Lead (mm)	Stroke (mm) In increments of 100mm	Speed (mm/s)	Load capacity (Note 1)	Positioning repeatability (mm) (Note 2)
ICSA2 [ICSPA2] -SA□M-A-***-***-T1-△-SC	X-axis	ISA [ISPA] -SXM-A-60-8-***-T1	Absolute	60	8	100 ~ 600	1 ~ 400	19.2 ~ 6.4	±0.02 [±0.01]
	Y-axis	ISA [ISPA] -SYM-A-60-8-***-T1				100 ~ 400			
ICSA2 [ICSPA2] -SA□M-I-***-***-T1-△-SC	X-axis	ISA [ISPA] -SXM-I-60-8-***-T1	Incremental			100 ~ 600			
	Y-axis	ISA [ISPA] -SYM-I-60-8-***-T1				100 ~ 400			

* In the above model names, □ indicates the configuration direction, *** the stroke/applicable options (stroke is specified in centimeters), △ the cable length.

Options

Name	Code	Page	Remarks
AQ seal	AQ	P13	
Brake	B	P13	
Creep sensor	C	P13	
Home limit switch	L	P14	
Reverse homing specification	NM	P14	
Guide with ball-retaining mechanism	RT	P14	

Common Specifications

Drive system (Note 4)	Ball screw, rolled C10 [equivalent to rolled C5]
Backlash (Note 5)	0.05mm or less [0.02mm or less]
Guide	Integrated with base
Base	Material: Aluminum with white alumite treatment
Cable length (Note 6)	3L: 3m, 5L: 5m, □L : Length specification
Cable management	SC: Self-standing cable

Load Capacity by Acceleration (kg)

Acceleration (G)	Y-axis stroke (mm)			
	100	200	300	400
0.3	19.2	14.3	9.3	6.4
0.4	12.7	12	9.3	6.4
0.5	9.2	8.5	7.8	6.4
0.6	6.2	5.5	4.8	4.1
0.7				
0.8				
0.9				
1.0				

Maximum Speed by Stroke (mm/sec)

Axis	Stroke (mm)	
	100 ~ 400	500 ~ 600
X-axis	400	
Y-axis	400	-

Configuration direction

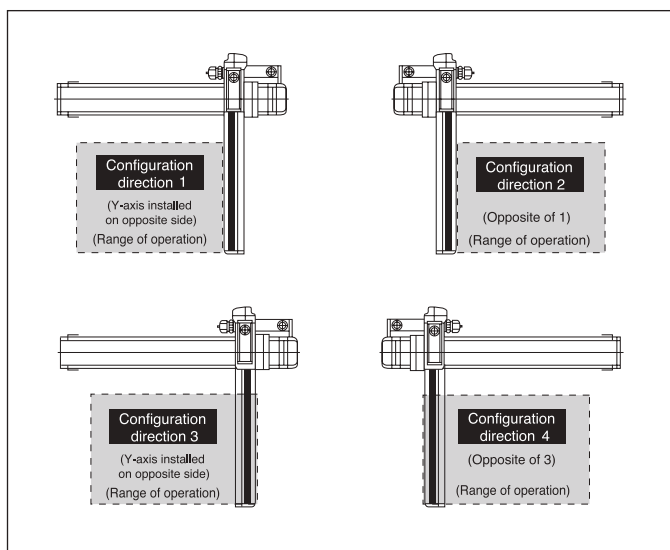

Applicable Controller Specifications

Applicable controller	Controller type	Model	Page
X-SEL	General-purpose type	XSEL-K-2-60□-60□-□-□□□-□-□	
	Compact type	XSEL-J-2-60□-60□-□-□□□-□-□	



(Note 1) The load capacity assumes operation at the rated acceleration (0.3 G). The actuator can be operated at accelerations beyond the rated acceleration, but the load capacity will decrease (refer to the table of load capacity by acceleration).
 (Notes 2, 3, 4) The figures in brackets apply to the ICSPA2.
 (Note 5) The cable length measures from the Y-axis connector box to the controller.
 The standard lengths are 3 m and 5 m, but other lengths can also be specified in meters up to 20 m (e.g., 10L = 10 m).

* Refer to page 59 for other points to note.

Self-standing Cable Specification (Cable Management Code: SC)

Dimensions

* Note that changing the home direction will require the actuator to be returned to IAI for adjustment.

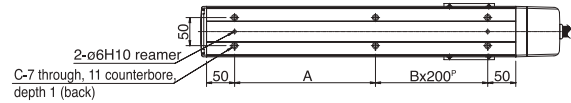
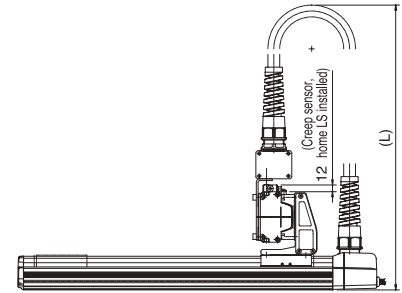
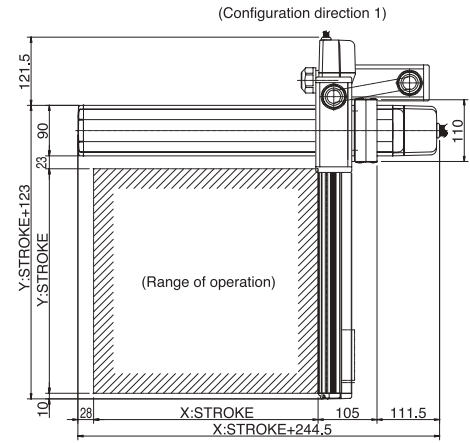
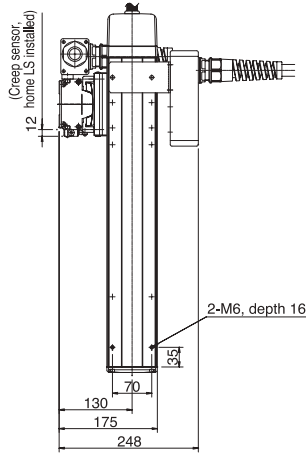

		Dimension L					
Yst	Xst	100	200	300	400	500	600
100		480	530	580	630	680	730
200		530	580	630	680	730	780
300		580	630	680	730	780	830
400		630	680	730	780	830	880

X stroke	100	200	300	400	500	600
A	151	251	151	251	151	251
B	0	0	1	1	2	2
C	4	4	6	6	8	8

* Note that changing the home direction will require the actuator to be returned to IAI for adjustment.

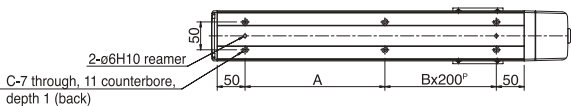
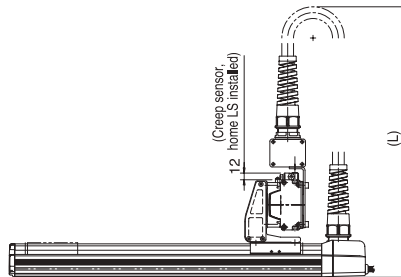
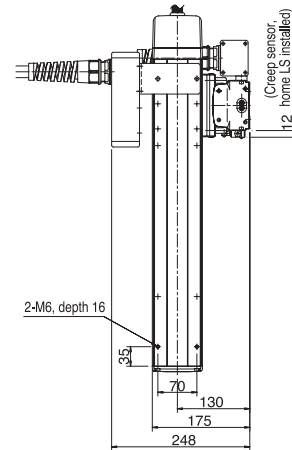
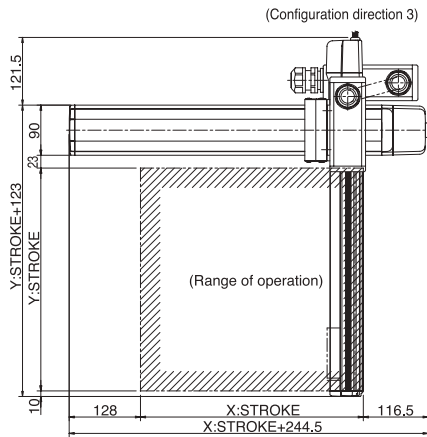

		Dimension L					
Yst	Xst	100	200	300	400	500	600
100		480	530	580	630	680	730
200		530	580	630	680	730	780
300		580	630	680	730	780	830
400		630	680	730	780	830	880

X stroke	100	200	300	400	500	600
A	151	251	151	251	151	251
B	0	0	1	1	2	2
C	4	4	6	6	8	8

ICSA2-S1C□H Cartesian Robot: X-Y 2-Axes Configuration, XYS (Y-Axis Slider Mount) Type
ICSPA2-S1C□H Cartesian Robot: X-Y 2-Axes Configuration, XYS (Y-Axis Slider Mount) Type High-Precision Specification

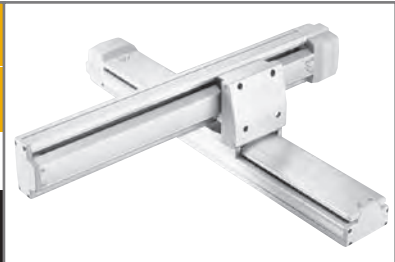

Type XYS type Stroke X-axis: 200~800mm Y-axis: 100~500mm Load capacity 9.7kg ~ 5.6kg

Model specification items Series Type Encoder type X-axis stroke + options Y-axis stroke + options Applicable controller Cable length Cable management
 ICSA2-S1C1H-A-80AQLNM-50AQL-T1-5L-SC

* Refer to page 61 for the details of model specification items.

Models/Specifications

Model	Axis configuration		Encoder type	Motor output (W)	Lead (mm)	Stroke (mm) In increments of 100mm	Speed (mm/s) (Note 1)	Load capacity (Note 2)	Positioning repeatability (mm) (Note 3)
ICSA2 [ICSPA2]-S1C□H-A-***-***-T1-△-SC	X-axis	ISA [ISPA]-MXM-A-100-20-***-T1	Absolute	100	20	200 ~ 800	1 ~ 1000	9.7 ~ 5.6	±0.02 [±0.01]
	Y-axis	ISA [ISPA]-MYM-A-100-20-***-T1				100 ~ 500			
ICSA2 [ICSPA2]-S1C□H-I-***-***-T1-△-SC	X-axis	ISA [ISPA]-MXM-I-100-20-***-T1	Incremental			200 ~ 800			
	Y-axis	ISA [ISPA]-MYM-I-100-20-***-T1				100 ~ 500			

* In the above model names, □ indicates the configuration direction, *** the stroke/applicable options (stroke is specified in centimeters), △ the cable length.

Options

Name	Code	Page	Remarks
AQ seal	AQ	P13	
Brake	B	P13	
Creep sensor	C	P13	
Home limit switch	L	P14	
Reverse homing specification	NM	P14	
Guide with ball-retaining mechanism	RT	P14	

Common Specifications

Drive system (Note 4)	Ball screw, rolled C10 [equivalent to rolled C5]
Backlash (Note 5)	0.05mm or less [0.02mm or less]
Guide	Integrated with base
Base	Material: Aluminum with white alumite treatment
Cable length (Note 6)	3L: 3m, 5L: 5m, □L : Length specification
Cable management	SC: Self-standing cable

Load Capacity by Acceleration (kg)

Y-axis stroke (mm) / Acceleration (G)	100	200	300	400	500
0.3	9.7	8.7	7.7	6.7	5.6
0.4	4.7	3.7	2.7	1.7	0.6
0.5	1.7	0.7			
0.6					
0.7					
0.8					
0.9					
1.0					

Maximum Speed by Stroke (mm/sec)

Stroke (mm) / Axis	100	200 ~ 500	600 ~ 700	800
X-axis	-	1000		795
Y-axis	1000		-	-

Configuration direction

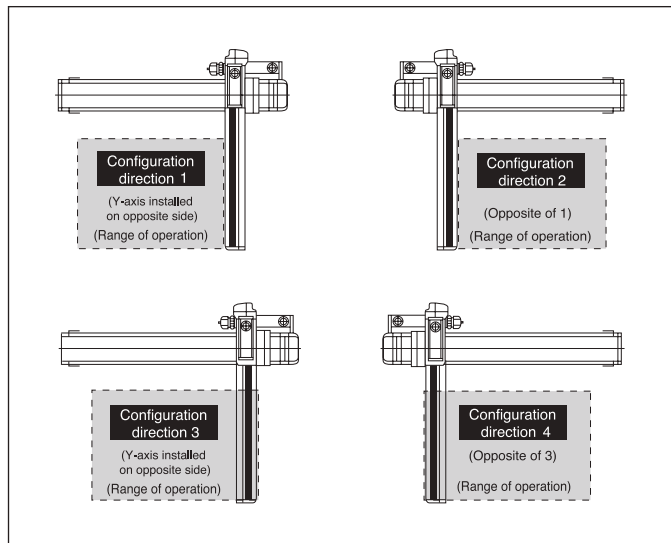

Applicable Controller Specifications

Applicable controller	Controller type	Model	Page
X-SEL	General-purpose type	XSEL-K-2-100□-100□-□-□□□-□□	
	Compact type	XSEL-J-2-100□-100□-□-□□□-□□	

Caution

(Note 1) The maximum speed will vary depending on the stroke. (Refer to the table of maximum speed by stroke.)
 (Note 2) The load capacity assumes operation at the rated acceleration (0.3 G). The actuator can be operated at accelerations beyond the rated acceleration, but the load capacity will decrease (refer to the table of load capacity by acceleration).
 (Notes 3, 4, 5) The figures in brackets apply to the ICSPA2.
 (Note 6) The cable length measures from the X-axis connector box to the controller. The standard lengths are 3 m and 5 m, but other lengths can also be specified in meters up to 20 m (e.g., 10L = 10 m).

* Refer to page 59 for other points to note.

Self-standing Cable Specification (Cable Management Code: SC)

Dimensions

* Note that changing the home direction will require the actuator to be returned to IAI for adjustment.

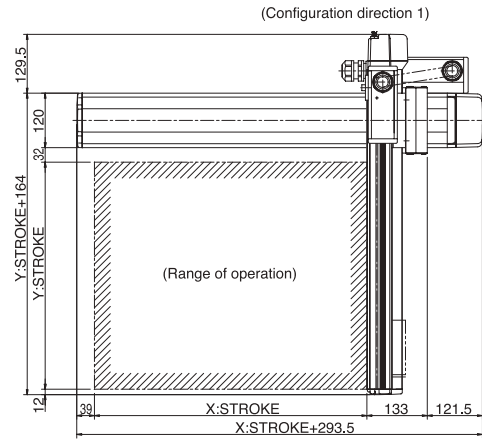
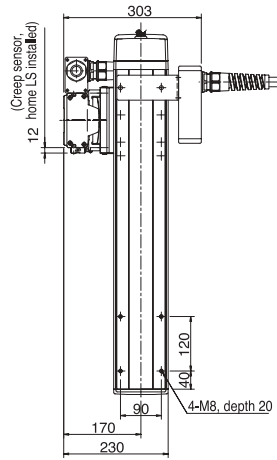

		Dimension L						
Yst	Xst	200	300	400	500	600	700	800
100		550	600	650	700	750	800	850
200		600	650	700	750	800	850	900
300		650	700	750	800	850	900	950
400		700	750	800	850	900	950	1000
500		750	800	850	900	950	1000	1050

X stroke	200	300	400	500	600	700	800
A	104	204	104	204	104	204	104
B	1	1	2	2	3	3	4
C	6	6	8	8	10	10	12

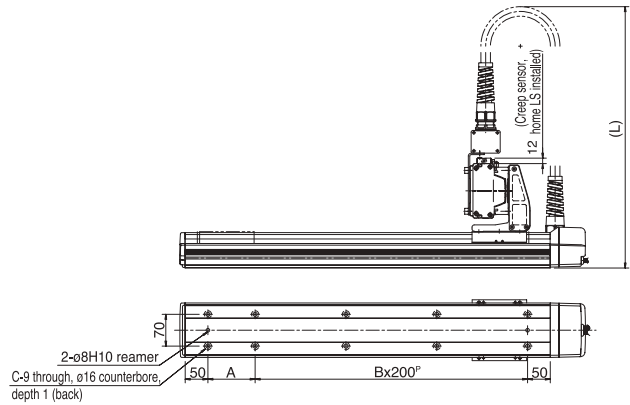

* Note that changing the home direction will require the actuator to be returned to IAI for adjustment.

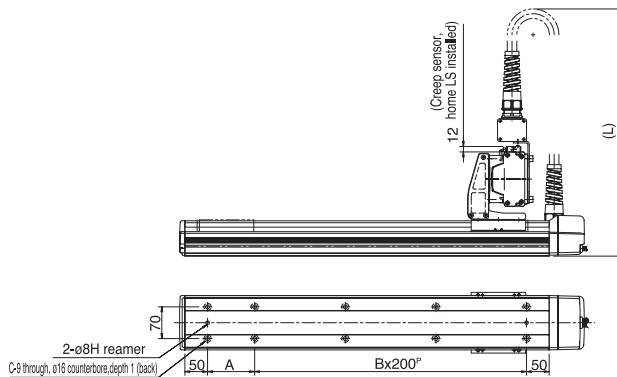
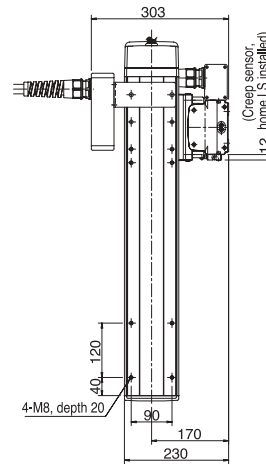
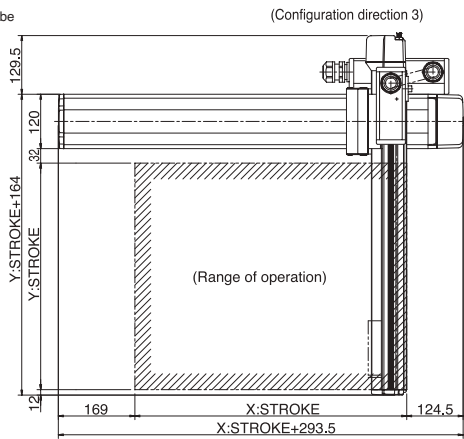

		Dimension L						
Yst	Xst	200	300	400	500	600	700	800
100		550	600	650	700	750	800	850
200		600	650	700	750	800	850	900
300		650	700	750	800	850	900	950
400		700	750	800	850	900	950	1000
500		750	800	850	900	950	1000	1050

X stroke	200	300	400	500	600	700	800
A	104	204	104	204	104	204	104
B	1	1	2	2	3	3	4
C	6	6	8	8	10	10	12

ICSA2-S1C□M Cartesian Robot: X-Y 2-Axes Configuration, XYS (Y-Axis Slider Mount) Type
ICSPA2-S1C□M Cartesian Robot: X-Y 2-Axes Configuration, XYS (Y-Axis Slider Mount) Type **High-Precision Specification**

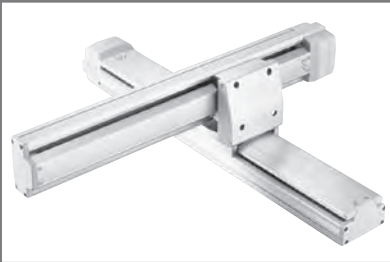

Type	XYS type	Stroke	X-axis: 200~800mm Y-axis: 100~500mm	Load capacity	29.7kg ~ 9.7kg			
Model specification items	Series	Type	Encoder type	X-axis stroke + options	Y-axis stroke + options	Applicable controller	Cable length	Cable management
	ICSA2	-S1C1M	- A	- 80AQLNM	- 50AQL	- T1	- 5L	- SC

* Refer to page 61 for the details of model specification items.

Models/Specifications

Model	Axis configuration	Encoder type	Motor output (W)	Lead (mm)	Stroke (mm) In increments of 100mm	Speed (mm/s) (Note 1)	Load capacity (Note 2)	Positioning repeatability (mm) (Note 3)
ICSA2 [ICSPA2] -S1C□M-A-***-***-T1-△-SC	X-axis	Absolute	100	10	200 ~ 800	1 ~ 500	29.7 ~ 9.7	±0.02 [±0.01]
	Y-axis				100 ~ 500			
ICSA2 [ICSPA2] -S1C□M-I-***-***-T1-△-SC	X-axis	Incremental						
	Y-axis				200 ~ 800			
					100 ~ 500			

* In the above model names, □ indicates the configuration direction, *** the stroke/applicable options (stroke is specified in centimeters), △ the cable length.

* In the above model names, □ indicates the configuration direction, *** the stroke/applicable options (stroke is specified in centimeters), △ the cable length.

Options

Name	Code	Page	Remarks
AQ seal	AQ	P13	
Brake	B	P13	
Creep sensor	C	P13	
Home limit switch	L	P14	
Reverse homing specification	NM	P14	
Guide with ball-retaining mechanism	RT	P14	

Common Specifications

Drive system (Note 4)	Ball screw, rolled C10 [equivalent to rolled C5]
Backlash (Note 5)	0.05mm or less [0.02mm or less]
Guide	Integrated with base
Base	Material: Aluminum with white alumite treatment
Cable length (Note 6)	3L: 3m, 5L: 5m, □L : Length specification
Cable management	SC: Self-standing cable

Load Capacity by Acceleration (kg)

Acceleration (G)	Y-axis stroke (mm)				
	100	200	300	400	500
0.3	29.7	28.7	19.3	13.6	9.7
0.4	19.7	18.7	17.7	13.6	9.7
0.5	13.7	12.7	11.7	10.7	9.7
0.6	9.7	8.7	7.7	6.7	5.6
0.7					
0.8					
0.9					
1.0					

Maximum Speed by Stroke (mm/sec)

Axis	Stroke (mm)				
	100	200 ~ 500	600	700	800
X-axis	-	500	480	380	
Y-axis	500	-	-	-	-

Configuration direction

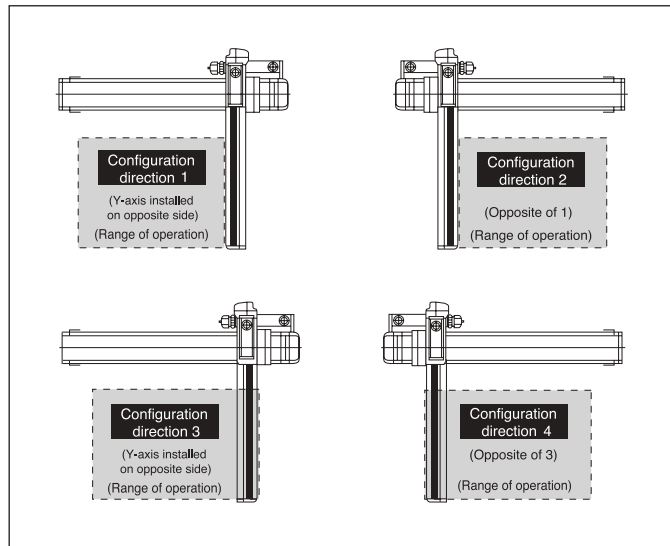

Applicable Controller Specifications

Applicable controller	Controller type	Model	Page
X-SEL	General-purpose type	XSEL-K-2-100□-100□-□-□□□-□-□	
	Compact type	XSEL-J-2-100□-100□-□-□□□-□-□	

Caution

(Note 1) The maximum speed will vary depending on the stroke. (Refer to the table of maximum speed by stroke.)
 (Note 2) The load capacity assumes operation at the rated acceleration (0.3 G). The actuator can be operated at accelerations beyond the rated acceleration, but the load capacity will decrease (refer to the table of load capacity by acceleration).
 (Notes 3, 4, 5) The figures in brackets apply to the ICSPA2.
 (Note 6) The cable length measures from the X-axis connector box to the controller. The standard lengths are 3 m and 5 m, but other lengths can also be specified in meters up to 20 m (e.g., 10L = 10 m).

* Refer to page 59 for other points to note.

Self-standing Cable Specification (Cable Management Code: SC)

Single-Axis Robots
Cartesian Robots

Dimensions

* Note that changing the home direction will require the actuator to be returned to IAI for adjustment.

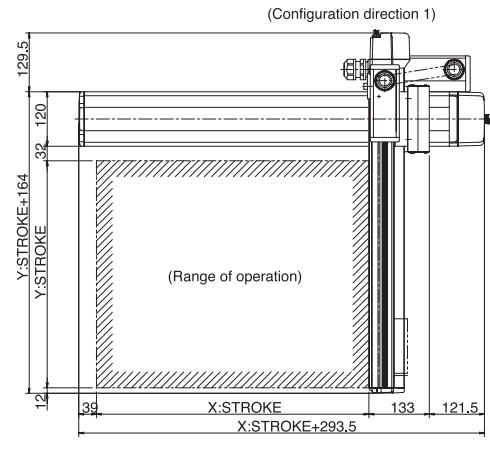
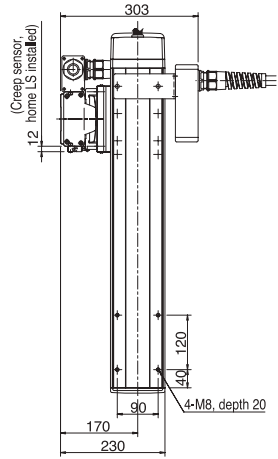

		Dimension L							
Y _{st}	X _{st}	200	300	400	500	600	700	800	
100		550	600	650	700	750	800	850	
200		600	650	700	750	800	850	900	
300		650	700	750	800	850	900	950	
400		700	750	800	850	900	950	1000	
500		750	800	850	900	950	1000	1050	

X stroke	200	300	400	500	600	700	800
A	104	204	104	204	104	204	104
B	1	1	2	2	3	3	4
C	6	6	8	8	10	10	12

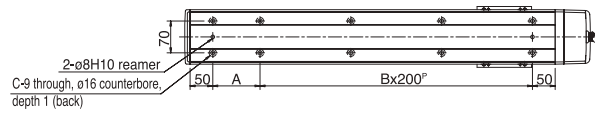
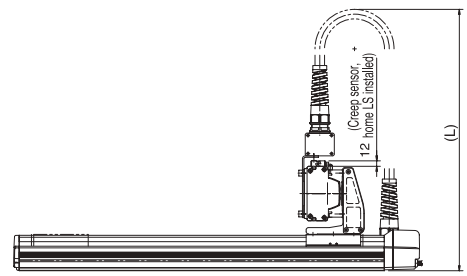

* Note that changing the home direction will require the actuator to be returned to IAI for adjustment.

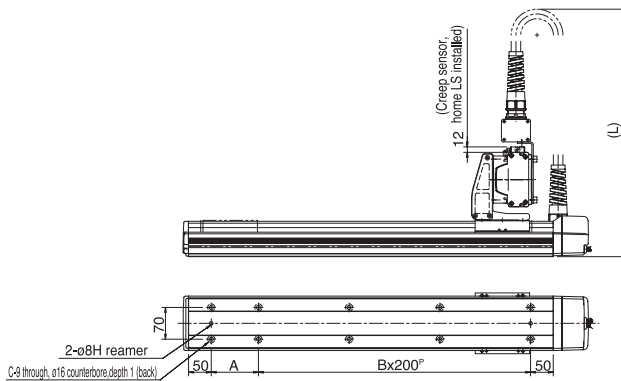
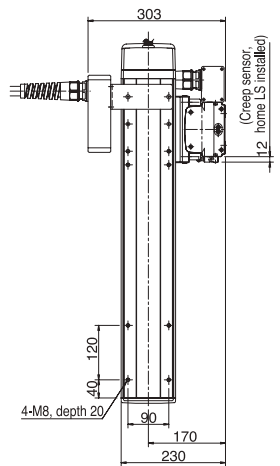
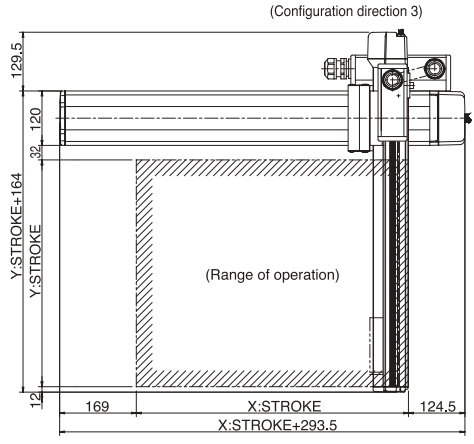

		Dimension L							
Y _{st}	X _{st}	200	300	400	500	600	700	800	
100		550	600	650	700	750	800	850	
200		600	650	700	750	800	850	900	
300		650	700	750	800	850	900	950	
400		700	750	800	850	900	950	1000	
500		750	800	850	900	950	1000	1050	

X stroke	200	300	400	500	600	700	800
A	104	204	104	204	104	204	104
B	1	1	2	2	3	3	4
C	6	6	8	8	10	10	12

ICSA2-S2C□H

Cartesian Robot: X-Y 2-Axes Configuration, XYS (Y-Axis Slider Mount) Type

ICSPA2-S2C□H

Cartesian Robot: X-Y 2-Axes Configuration, XYS (Y-Axis Slider Mount) Type High-Precision Specification

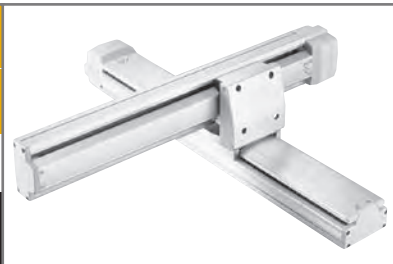

Type: XYS type Stroke: X-axis: 200~800mm Y-axis: 100~500mm Load capacity: 29.2kg ~ 9.7kg

Model specification items: Series: ICSA2 - S2C1H - A - 80AQLNM - 50AQL - T1 - 5L - SC

* Refer to page 61 for the details of model specification items.

Models/Specifications

Model	Axis configuration		Encoder type	Motor output (W)	Lead (mm)	Stroke (mm) In increments of 100mm	Speed (mm/s) (Note 1)	Load capacity (Note 2)	Positioning repeatability (mm) (Note 3)
ICSA2 [ICSPA2]-S2C□H-A-***-***-T1-△-SC	X-axis	ISA [ISPA]-MXM-A-200-20-***-T1	Absolute	200	20	200 ~ 800	1 ~ 1000	29.2 ~ 9.7	±0.02
	Y-axis	ISA [ISPA]-MYM-A-200-20-***-T1				100 ~ 500			
ICSA2 [ICSPA2]-S2C□H-I-***-***-T1-△-SC	X-axis	ISA [ISPA]-MXM-I-200-20-***-T1	Incremental			200 ~ 800			
	Y-axis	ISA [ISPA]-MYM-I-200-20-***-T1				100 ~ 500			

* In the above model names, □ indicates the configuration direction, *** the stroke/applicable options (stroke is specified in centimeters), △ the cable length.

Options

Name	Code	Page	Remarks
AQ seal	AQ	P13	
Brake	B	P13	
Creep sensor	C	P13	
Home limit switch	L	P14	
Reverse homing specification	NM	P14	
Guide with ball-retaining mechanism	RT	P14	

Common Specifications

Drive system (Note 4)	Ball screw, rolled C10 [equivalent to rolled C5]
Backlash (Note 5)	0.05mm or less [0.02mm or less]
Guide	Integrated with base
Base	Material: Aluminum with white alumite treatment
Cable length (Note 6)	3L: 3m, 5L: 5m, □L : Length specification
Cable management	SC: Self-standing cable

Load Capacity by Acceleration (kg)

Acceleration (G)	Y-axis stroke (mm)				
	100	200	300	400	500
0.3	29.2	28.2	19.3	13.6	9.7
0.4	19.2	18.2	17.2	13.6	9.7
0.5	13.2	12.2	11.2	10.2	9.1
0.6	9.2	8.2	7.2	6.2	5.1
0.7	6.2	5.2	4.2	3.2	2.1
0.8	4.2	3.2	2.2	1.2	0.1
0.9	2.7	1.7	0.7		
1.0	1.2	0.2			

Maximum Speed by Stroke (mm/sec)

Axis	Stroke (mm)			
	100	200 ~ 500	600 ~ 700	800
X-axis	-	1000		795
Y-axis	1000		-	-

Configuration direction



Applicable Controller Specifications

Applicable controller	Controller type	Model	Page
X-SEL	General-purpose type	XSEL-K-2-200□-200□-□-□□□-□-□	
	Compact type	XSEL-J-2-200□-200□-□-□□□-□-□	



(Note 1) The maximum speed will vary depending on the stroke. (Refer to the table of maximum speed by stroke.)
 (Note 2) The load capacity assumes operation at the rated acceleration (0.3 G). The actuator can be operated at accelerations beyond the rated acceleration, but the load capacity will decrease (refer to the table of load capacity by acceleration).
 (Notes 3, 4, 5) The figures in brackets apply to the ICSPA2.
 (Note 6) The cable length measures from the X-axis connector box to the controller. The standard lengths are 3 m and 5 m, but other lengths can also be specified in meters up to 20 m (e.g., 10L = 10 m).

* Refer to page 59 for other points to note.

Self-standing Cable Specification (Cable Management Code: SC)

Single-Axis Robots
Cartesian Robots

Dimensions

* Note that changing the home direction will require the actuator to be returned to IAI for adjustment.

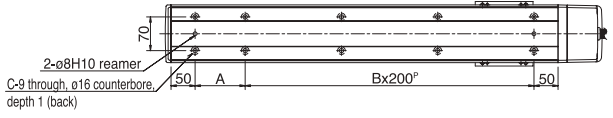
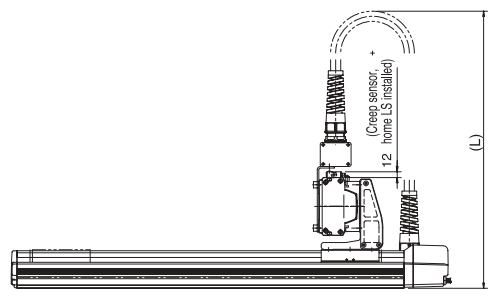
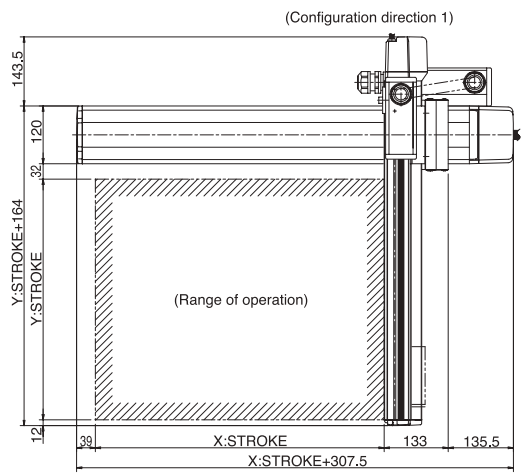
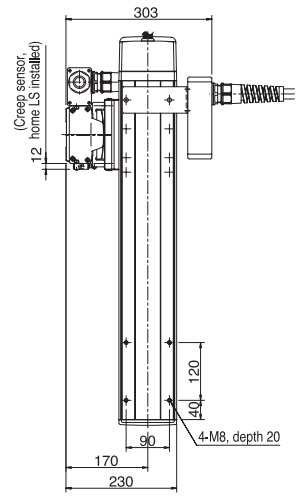

		Dimension L							
Yst	Xst	200	300	400	500	600	700	800	
100		550	600	650	700	750	800	850	
200		600	650	700	750	800	850	900	
300		650	700	750	800	850	900	950	
400		700	750	800	850	900	950	1000	
500		750	800	850	900	950	1000	1050	

X stroke	200	300	400	500	600	700	800
A	104	204	104	204	104	204	104
B	1	1	2	2	3	3	4
C	6	6	8	8	10	10	12

* Note that changing the home direction will require the actuator to be returned to IAI for adjustment.

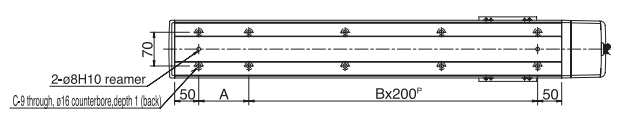
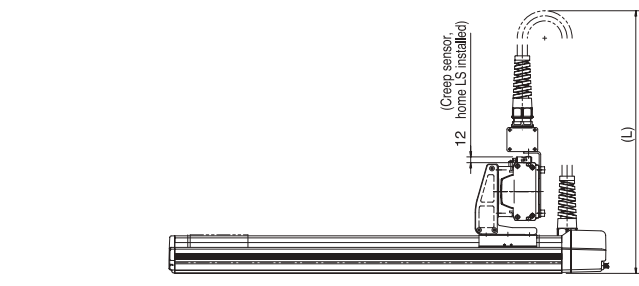
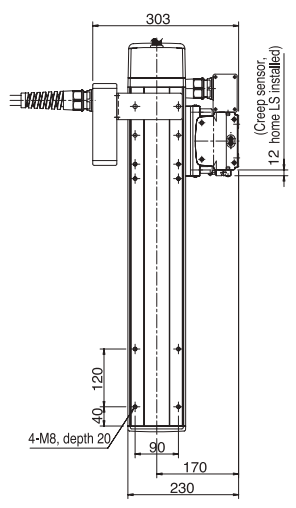
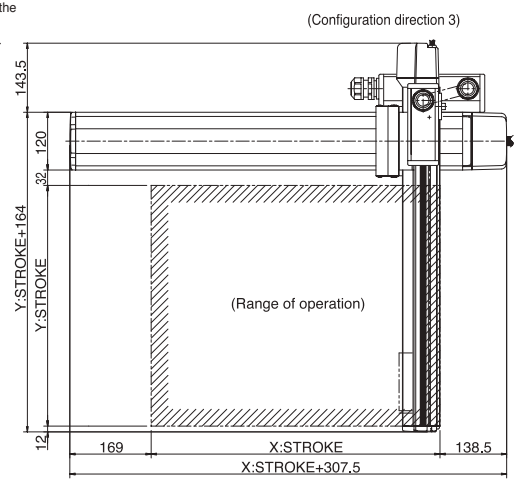

		Dimension L							
Yst	Xst	200	300	400	500	600	700	800	
100		550	600	650	700	750	800	850	
200		600	650	700	750	800	850	900	
300		650	700	750	800	850	900	950	
400		700	750	800	850	900	950	1000	
500		750	800	850	900	950	1000	1050	

X stroke	200	300	400	500	600	700	800
A	104	204	104	204	104	204	104
B	1	1	2	2	3	3	4
C	6	6	8	8	10	10	12

ICSA2-SG□H Cartesian Robot: X-Y 2-Axes Configuration, XYS (Y-Axis Slider Mount) Type

ICSPA2-SG□H Cartesian Robot: X-Y 2-Axes Configuration, XYS (Y-Axis Slider Mount) Type **High-Precision Specification**

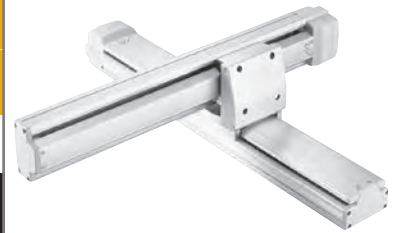

Type: XYS type Stroke: X-axis: 300-800mm Y-axis: 300-600mm Load capacity: 20.7kg ~ 8.4kg

Model specification items: Series: ICSA2 - Type: SG1H - Encoder type: A - X-axis stroke + options: 80AQLNM - Y-axis stroke + options: 60AQL - Applicable controller: T1 - Cable length: 5L - Cable management: SC

* Refer to page 61 for the details of model specification items.

Models/Specifications

Model	Axis configuration		Encoder type	Motor output (W)	Lead (mm)	Stroke (mm) In increments of 100mm	Speed (mm/s)	Load capacity (Note 1)	Positioning repeatability (mm) (Note 2)
ICSA2 [ICSPA2] -SG□H-A-***-***-T1-△-SC	X-axis	ISA [ISPA] -LXM-A-200-20-***-T1	Absolute	200	20	300 ~ 800	1 ~ 1000	20.7 ~ 8.4	±0.02 [±0.01]
	Y-axis	ISA [ISPA] -LYM-A-200-20-***-T1				300 ~ 600			
ICSA2 [ICSPA2] -SG□H-I-***-***-T1-△-SC	X-axis	ISA [ISPA] -LXM-I-200-20-***-T1	Incremental						
	Y-axis	ISA [ISPA] -LYM-I-200-20-***-T1				300 ~ 600			

* In the above model names, □ indicates the configuration direction, *** the stroke/applicable options (stroke is specified in centimeters), △ the cable length.

Options

Name	Code	Page	Remarks
AQ seal	AQ	P13	
Brake	B	P13	
Creep sensor	C	P13	
Home limit switch	L	P14	
Reverse homing specification	NM	P14	
Guide with ball-retaining mechanism	RT	P14	

Common Specifications

Drive system (Note 3)	Ball screw, rolled C10 [equivalent to rolled C5]
Backlash (Note 4)	0.05mm or less [0.02mm or less]
Guide	Integrated with base
Base	Material: Aluminum with white alumite treatment
Cable length (Note 5)	3L: 3m, 5L: 5m, □L : Length specification
Cable management	SC: Self-standing cable

Load Capacity by Acceleration (kg)

Acceleration (G)	Y-axis stroke (mm) 300	400	500	600
0.3	20.7	18.2	12.5	8.4
0.4	10.7	9.1	7.5	6.0
0.5	4.7	3.1	1.5	
0.6	0.7			
0.7				
0.8				
0.9				
1.0				

Maximum Speed by Stroke (mm/sec)

Axis	Stroke (mm) 300 ~ 600	700 ~ 800
X-axis	1000	
Y-axis	1000	-

Configuration direction

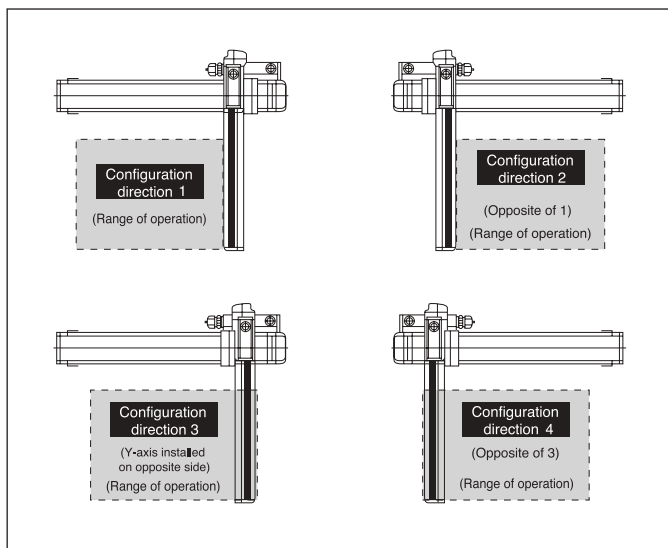

Applicable Controller Specifications

Applicable controller	Controller type	Model	Page
X-SEL	General-purpose type	XSEL-K-2-200□-200□-□-□□□-□-□	
	Compact type	XSEL-J-2-200□-200□-□-□□□-□-□	

Caution
 (Note 1) The load capacity assumes operation at the rated acceleration (0.3 G). The actuator can be operated at accelerations beyond the rated acceleration, but the load capacity will decrease (refer to the table of load capacity by acceleration).
 (Notes 2, 3, 4) The figures in brackets apply to the ICSPA2.
 (Note 5) The cable length measures from the X-axis connector box to the controller. The standard lengths are 3 m and 5 m, but other lengths can also be specified in meters up to 20 m (e.g., 10L = 10 m).

* Refer to page 59 for other points to note.

Self-standing Cable Specification (Cable Management Code: SC)

Dimensions

* Note that changing the home direction will require the actuator to be returned to IAI for adjustment.

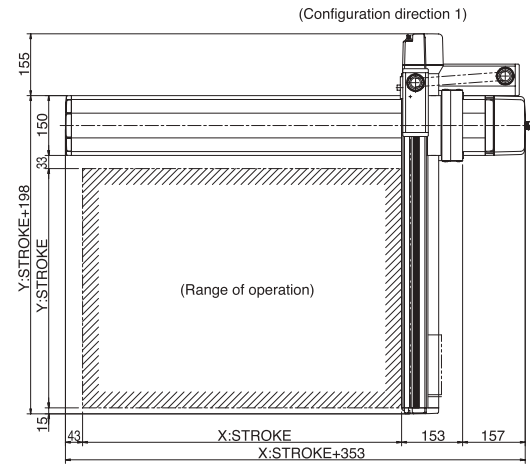
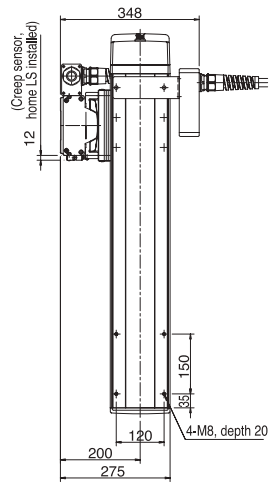

		Dimension L					
Yst	Xst	300	400	500	600	700	800
300		700	750	800	850	900	950
400		750	800	850	900	950	1000
500		800	850	900	950	1000	1050
600		850	900	950	1000	1050	1100

X stroke	300	400	500	600	700	800
A	238	138	238	138	238	138
B	1	2	2	3	3	4
C	6	8	8	10	10	12

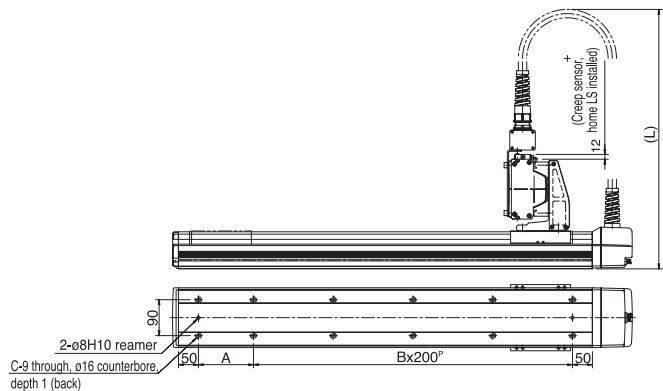

* Note that changing the home direction will require the actuator to be returned to IAI for adjustment.

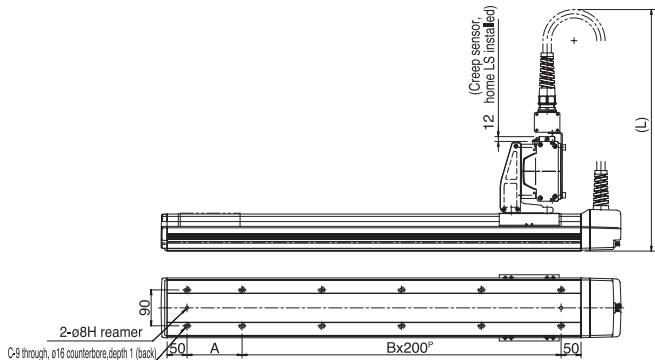
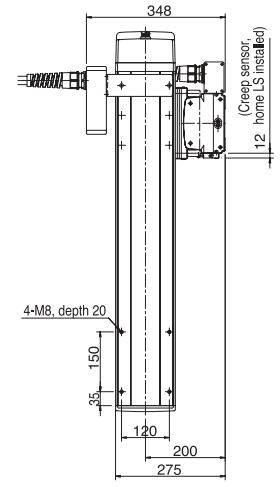
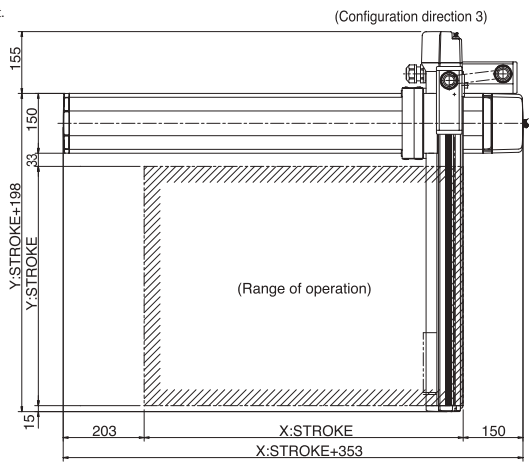

		Dimension L					
Yst	Xst	300	400	500	600	700	800
300		700	750	800	850	900	950
400		750	800	850	900	950	1000
500		800	850	900	950	1000	1050
600		850	900	950	1000	1050	1100

X stroke	300	400	500	600	700	800
A	238	138	238	138	238	138
B	1	2	2	3	3	4
C	6	8	8	10	10	12

ICSA2-ZAH Cartesian Robot: X-Z 2-Axes Configuration, XZ (Z-Axis Base Mount) Type

ICSPA2-ZAH Cartesian Robot: X-Z 2-Axes Configuration, XZ (Z-Axis Base Mount) Type **High-Precision Specification**

Type XZ type Stroke X-axis: 100~600mm Z-axis: 100~300mm Load capacity 4kg ~ 2.6kg

Model specification items Series Type Encoder type X-axis stroke + options Z-axis stroke + options Applicable controller Cable length Cable management
ICSA2 - ZAH - A - 60AQLNM - 30AQLB - T1 - 5L - CT



* Refer to page 61 for the details of model specification items.

Models/Specifications

Model	Axis configuration		Encoder type	Motor output (W)	Lead (mm)	Stroke (mm) In increments of 100mm	Speed (mm/s)	Load capacity (Note 1)	Positioning repeatability (mm) (Note 2)
ICSA [ICSPA2] -ZAH-A-***-***-B-T1-△-CT	X-axis	ISA [ISA] -SXM-A-60-16-***-T1	Absolute	60	16	100 ~ 600	1 ~ 800	4 ~ 2.6	±0.02 [±0.01]
	Z-axis	ISA [ISA] -SZM-A-60-8-***-T1-B			8	100 ~ 300	1 ~ 400		
ICSA [ICSPA2] -ZAH-I-***-***-B-T1-△-CT	X-axis	ISA [ISA] -SXM-I-60-16-***-T1	Incremental		16	100 ~ 600	1 ~ 800		
	Z-axis	ISA [ISA] -SZM-I-60-8-***-T1-B			8	100 ~ 300	1 ~ 400		

* In the above model names, *** indicates the stroke/applicable options (stroke is specified in centimeters), and △ the cable length.

Options

Name	Code	Page	Remarks
AQ seal	AQ	P13	
Brake	B	P13	Standard equipment on Z-axis
Creep sensor	C	P13	
Home limit switch	L	P14	
Reverse homing specification	NM	P14	
Guide with ball-retaining mechanism	RT	P14	

Common Specifications

Drive system (Note 3)	Ball screw, rolled C10 [equivalent to rolled C5]
Backlash (Note 4)	0.05mm or less [0.02mm or less]
Guide	Integrated with base
Base	Material: Aluminum with white alumite treatment
Cable length (Note 5)	3L: 3m, 5L: 5m, □L : Length specification
Cable management	CT: Cable track

Load Capacity by Acceleration (kg)

Acceleration (G)	Z-axis stroke (mm)		
	100	200	300
0.3	4.0	3.3	2.6
0.4	1.0	0.3	
0.5			
0.6			
0.7			
0.8			
0.9			
1.0			

Maximum Speed by Stroke (mm/sec)

Axis	Stroke (mm)	
	100 ~ 300	400 ~ 600
X-axis	800	
Z-axis	400	-

Applicable Controller Specifications

Applicable controller	Controller type	Model	Page
X-SEL	General-purpose type	XSEL-K-2-60 □-60B□-□-□□□-□-□	
	Compact type	XSEL-J-2-60 □-60B□-□-□□□-□-□	

Caution

(Note 1) The load capacity assumes operation at the rated acceleration (0.3 G). The actuator can be operated at accelerations beyond the rated acceleration, but the load capacity will decrease (refer to the table of load capacity by acceleration).
 (Notes 2, 3, 4) The figures in brackets apply to the ICSPA2.
 (Note 5) The cable length measures from the X-axis connector box to the controller. The standard lengths are 3 m and 5 m, but other lengths can also be specified in meters up to 20 m (e.g., 10L = 10 m).

* Refer to page 59 for other points to note.

Cable Track Specification (Cable Management Code: CT)

Dimensions

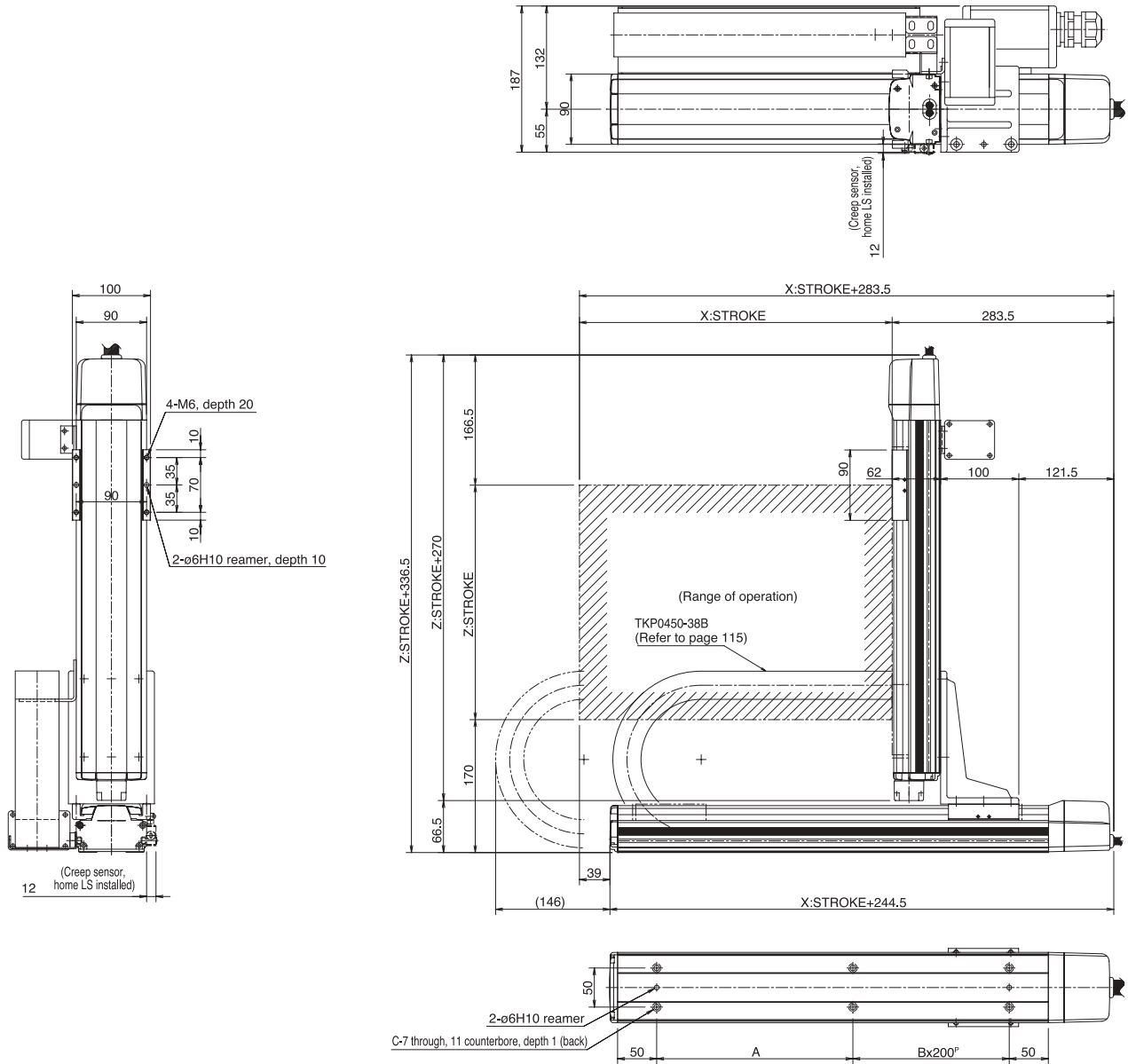

X stroke	100	200	300	400	500	600
A	151	251	151	251	151	251
B	0	0	1	1	2	2
C	4	4	6	6	8	8

ICSA2-ZAM

Cartesian Robot: X-Z 2-Axes Configuration, XZ (Z-Axis Base Mount) Type

ICSPA2-ZAM

Cartesian Robot: X-Z 2-Axes Configuration, XZ (Z-Axis Base Mount) Type **High-Precision Specification**



Type XZ type Stroke X-axis: 100-600mm Z-axis: 100-300mm Load capacity 10kg ~ 6kg

Model specification items Series Type Encoder type X-axis stroke + options Z-axis stroke + options Applicable controller Cable length Cable management
 ICSA2 - ZAM - A - 60AQLNM - 30AQB - T1 - 5L - CT

* Refer to page 61 for the details of model specification items.

Models/Specifications

Model	Axis configuration		Encoder type	Motor output (W)	Lead (mm)	Stroke (mm) In increments of 100mm	Speed (mm/s)	Load capacity (Note 1)	Positioning repeatability (mm) (Note 2)
ICSA2 [ICSPA2] -ZAM-A-***-***-B-T1-△-CT	X-axis	ISA [ISPA] -SXM-A-60-8-***-T1	Absolute	60	8	100 ~ 600	1 ~ 400	10 ~ 6	±0.02 [±0.01]
	Z-axis	ISA [ISPA] -SZM-A-60-4-***-T1-B			4	100 ~ 300	1 ~ 200		
ICSA2 [ICSPA2] -ZAM-I-***-***-B-T1-△-CT	X-axis	ISA [ISPA] -SXM-I-60-8-***-T1	Incremental		8	100 ~ 600	1 ~ 400		
	Z-axis	ISA [ISPA] -SZM-I-60-4-***-T1-B			4	100 ~ 300	1 ~ 200		

* In the above model names, *** indicates the stroke/applicable options (stroke is specified in centimeters), and △ the cable length.

Options

Name	Code	Page	Remarks
AQ seal	AQ	P13	
Brake	B	P13	Standard equipment on Z-axis
Creep sensor	C	P13	
Home limit switch	L	P14	
Reverse homing specification	NM	P14	
Guide with ball-retaining mechanism	RT	P14	

Common Specifications

Drive system (Note 3)	Ball screw, rolled C10 [equivalent to rolled C5]
Backlash (Note 4)	0.05mm or less [0.02mm or less]
Guide	Integrated with base
Base	Material: Aluminum with white alumite treatment
Cable length (Note 5)	3L: 3m, 5L: 5m, □L : Length specification
Cable management	CT: Cable track

Load Capacity by Acceleration (kg)

Acceleration (G)	Z-axis stroke (mm)		
	100	200	300
0.3	10.0	7.5	6.0
0.4	8.5	6.0	4.0
0.5	7.0	4.5	3.0
0.6	4.0	3.3	2.0
0.7			
0.8			
0.9			
1.0			

* Assuming operation of the Z axis at its rated acceleration of 0.15 G, the load capacity varies according to the changes in acceleration of the X axis.

Maximum Speed by Stroke (mm/sec)

Axis	Stroke (mm)	
	100 ~ 300	400 ~ 600
X-axis	400	
Z-axis	200	-

Applicable Controller Specifications

Applicable controller	Controller type	Model	Page
X-SEL	General-purpose type	XSEL-K-2-60□-60B□-□-□□□-□-□	
	Compact type	XSEL-J-2-60□-60B□-□-□□□-□-□	

Caution

(Note 1) The load capacity assumes operation at the rated acceleration (0.3 G for the X-axis, 0.15 G for the Z-axis). The actuator can be operated at accelerations beyond the rated acceleration, but the load capacity will decrease (refer to the table of load capacity by acceleration). (Notes 2, 3, 4) The figures in brackets apply to the ICSPA2.

(Note 5) The cable length measures from the X-axis connector box to the controller. The standard lengths are 3 m and 5 m, but other lengths can also be specified in meters up to 20 m (e.g., 10L = 10 m).

* Refer to page 59 for other points to note.

Cable Track Specification (Cable Management Code: CT)

Dimensions

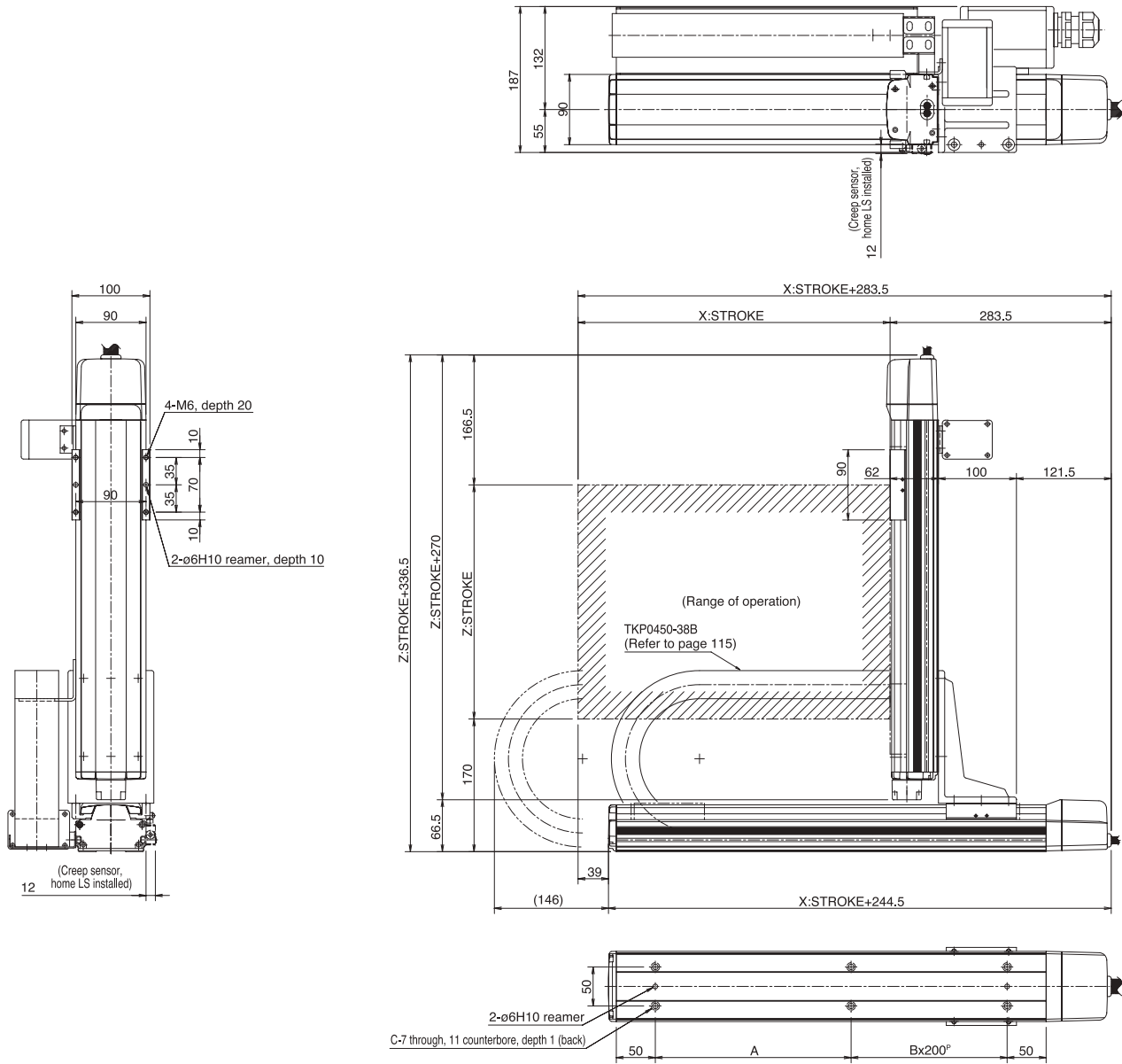

X stroke	100	200	300	400	500	600
A	151	251	151	251	151	251
B	0	0	1	1	2	2
C	4	4	6	6	8	8

ICSA2-Z1CH Cartesian Robot: X-Z 2-Axes Configuration, XZ (Z-Axis Base Mount) Type

ICSPA2-Z1CH Cartesian Robot: X-Z 2-Axes Configuration, XZ (Z-Axis Base Mount) Type **High-Precision Specification**

Type XZ type Stroke X-axis: 200~800mm Z-axis: 100~400mm Load capacity 8.5kg ~ 5.5kg

Model specification items Series Type Encoder type X-axis stroke + options Z-axis stroke + options Applicable controller Cable length Cable management
 ICSA2 - Z1CH - A - 80AQLNM - 40AQLBL - T1 - 5L - CT



* Refer to page 61 for the details of model specification items.

Models/Specifications

Model	Axis configuration		Encoder type	Motor output (W)	Lead (mm)	Stroke (mm) In increments of 100mm	Speed (mm/s) (Note 1)	Load capacity (Note 2)	Positioning repeatability (mm) (Note 3)
ICSA2 [ICSPA2] -Z1CH-A-***-***-B-T1-△-CT	X-axis	ISA [ISPA] -MXM-A-100-20-***-T1	Absolute	100	20	200 ~ 800	1 ~ 1000	8.5 ~ 5.5	±0.02 [±0.01]
	Z-axis	ISA [ISPA] -MZM-A-100-10-***-T1-B			10	100 ~ 400	1 ~ 500		
ICSA2 [ICSPA2] -Z1CH-I-***-***-B-T1-△-CT	X-axis	ISA [ISPA] -MXM-I-100-20-***-T1	Incremental		20	200 ~ 800	1 ~ 1000		
	Z-axis	ISA [ISPA] -MZM-I-100-10-***-T1-B			10	100 ~ 400	1 ~ 500		

* In the above model names, *** indicates the stroke/applicable options (stroke is specified in centimeters), and △ the cable length.

Options

Name	Code	Page	Remarks
AQ seal	AQ	P13	
Brake	B	P13	Standard equipment on Z-axis
Creep sensor	C	P13	
Home limit switch	L	P14	
Reverse homing specification	NM	P14	
Guide with ball-retaining mechanism	RT	P14	

Common Specifications

Drive system (Note 4)	Ball screw, rolled C10 [equivalent to rolled C5]
Backlash (Note 5)	0.05mm or less [0.02mm or less]
Guide	Integrated with base
Base	Material: Aluminum with white alumite treatment
Cable length (Note 6)	3L: 3m, 5L: 5m, □L : Length specification
Cable management	CT: Cable track

Load Capacity by Acceleration (kg)

Acceleration (G)	Z-axis stroke (mm)			
	100	200	300	400
0.3	8.5	7.5	6.5	5.5
0.4	3.5	2.5	1.5	0.5
0.5	0.5			
0.6				
0.7				
0.8				
0.9				
1.0				

Maximum Speed by Stroke (mm/sec)

Axis	Stroke (mm)			
	100	200 ~ 400	500 ~ 700	800
X-axis	-	1000		795
Z-axis	500		-	-

Applicable Controller Specifications

Applicable controller	Controller type	Model	Page
X-SEL	General-purpose type	XSEL-K-2-100□-100B□-□-□□□-□-□	
	Compact type	XSEL-J-2-100□-100B□-□-□□□-□-□	

Caution

(Note 1) The maximum speed will vary depending on the stroke. (Refer to the table of maximum speed by stroke.)
 (Note 2) The load capacity assumes operation at the rated acceleration (0.3 G). The actuator can be operated at accelerations beyond the rated acceleration, but the load capacity will decrease (refer to the table of load capacity by acceleration).
 (Notes 3, 4, 5) The figures in brackets apply to the ICSPA2.
 (Note 6) The cable length measures from the X-axis connector box to the controller. The standard lengths are 3 m and 5 m, but other lengths can also be specified in meters up to 20 m (e.g., 10L = 10 m).

* Refer to page 59 for other points to note.

Cable Track Specification (Cable Management Code: CT)

Dimensions

Single-Axis Robots
Cartesian Robots

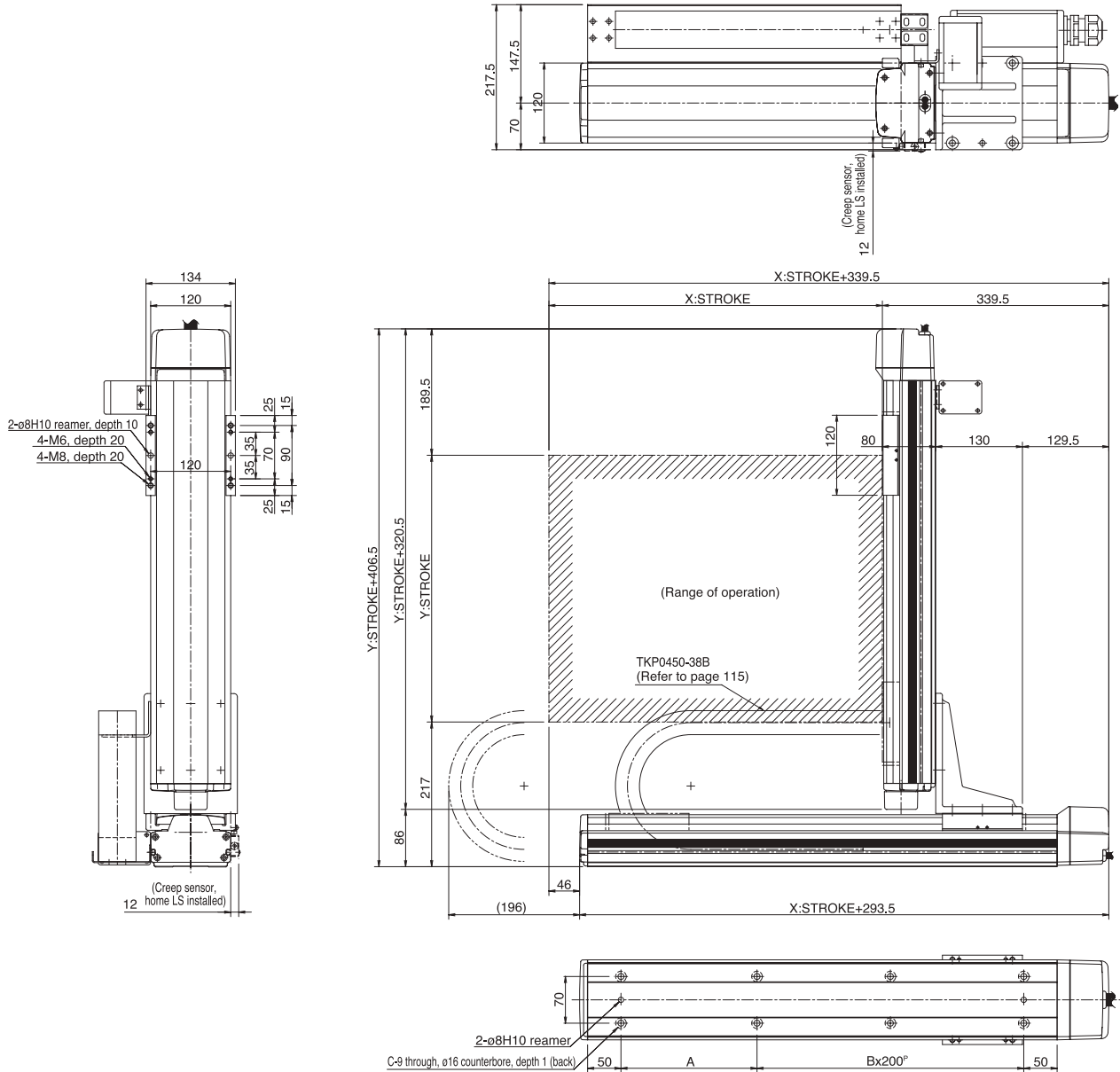

X stroke	200	300	400	500	600	700	800
A	104	204	104	204	104	204	104
B	1	1	2	2	3	3	4
C	6	6	8	8	10	10	12

ICSA2-Z1CM

Cartesian Robot: X-Z 2-Axes Configuration, XZ (Z-Axis Base Mount) Type

ICSPA2-Z1CM

Cartesian Robot: X-Z 2-Axes Configuration, XZ (Z-Axis Base Mount) Type **High-Precision Specification**



Type XZ type Stroke X-axis: 200-800mm Z-axis: 100-400mm Load capacity 19kg ~ 12kg

Model specification items Series Type Encoder type X-axis stroke + options Z-axis stroke + options Applicable controller Cable length Cable management
 ICSA 2-Z1CM - A - 80AQLNM - 40AQB - T1 - 5L - CT

* Refer to page 61 for the details of model specification items.

Models/Specifications

Model	Axis configuration		Encoder type	Motor output (W)	Lead (mm)	Stroke (mm) In increments of 100mm	Speed (mm/s) (Note 1)	Load capacity (Note 2)	Positioning repeatability (mm) (Note 3)
ICSA2 [ICSPA2] -Z1CM-A-***-***-B-T1-△-CT	X-axis	ISA [ISPA] -MXM-A-100-10-***-T1	Absolute	100	10	200 ~ 800	1 ~ 500	19 ~ 12	±0.02 [±0.01]
	Z-axis	ISA [ISPA] -MZM-A-100-5-***-T1-B			5	100 ~ 400	1 ~ 250		
ICSA2 [ICSPA2] -Z1CM-I-***-***-B-T1-△-CT	X-axis	ISA [ISPA] -MXM-I-100-10-***-T1	Incremental		10	200 ~ 800	1 ~ 500		
	Z-axis	ISA [ISPA] -MZM-I-100-5-***-T1-B			5	100 ~ 400	1 ~ 250		

* In the above model names, *** indicates the stroke/applicable options (stroke is specified in centimeters), and △ the cable length.

Options

Name	Code	Page	Remarks
AQ seal	AQ	P13	
Brake	B	P13	Standard equipment on Z-axis
Creep sensor	C	P13	
Home limit switch	L	P14	
Reverse homing specification	NM	P14	
Guide with ball-retaining mechanism	RT	P14	

Common Specifications

Drive system (Note 4)	Ball screw, rolled C10 [equivalent to rolled C5]
Backlash (Note 5)	0.05mm or less [0.02mm or less]
Guide	Integrated with base
Base	Material: Aluminum with white alumite treatment
Cable length (Note 6)	3L: 3m, 5L: 5m, □L : Length specification
Cable management	CT: Cable track

Load Capacity by Acceleration (kg)

Z-axis stroke (mm)	100	200	300	400
Acceleration (G)				
0.3	19.0	17.0	14.0	12.0
0.4	18.5	14.0	11.0	9.0
0.5	12.5	11.5	9.0	7.0
0.6	8.5	7.5	6.5	5.0
0.7				
0.8				
0.9				
1.0				

* Assuming operation of the Z axis at its rated acceleration of 0.15 G, the load capacity varies according to the changes in acceleration of the X axis.

Maximum Speed by Stroke (mm/sec)

Stroke (mm)	100	200 ~ 400	500 ~ 600	700	800
X-axis	—	500		480	380
Z-axis	250		—	—	—

Applicable Controller Specifications

Applicable controller	Controller type	Model	Page
X-SEL	General-purpose type	XSEL-K-2-100□-100B□-□-□□□-□-□	
	Compact type	XSEL-J-2-100□-100B□-□-□□□-□-□	

Caution

(Note 1) The maximum speed will vary depending on the stroke. (Refer to the table of maximum speed by stroke.)
 (Note 2) The load capacity assumes operation at the rated acceleration (0.3 G for the X-axis, 0.15 G for the Z-axis). The actuator can be operated at accelerations beyond the rated acceleration, but the load capacity will decrease (refer to the table of load capacity by acceleration).
 (Notes 3, 4, 5) The figures in brackets apply to the ICSPA2.
 (Note 6) The cable length measures from the X-axis connector box to the controller. The standard lengths are 3 m and 5 m, but other lengths can also be specified in meters up to 20 m (e.g., 10L = 10 m).

* Refer to page 59 for other points to note.

Cable Track Specification (Cable Management Code: CT)

Dimensions

Single-Axis Robots
Cartesian Robots

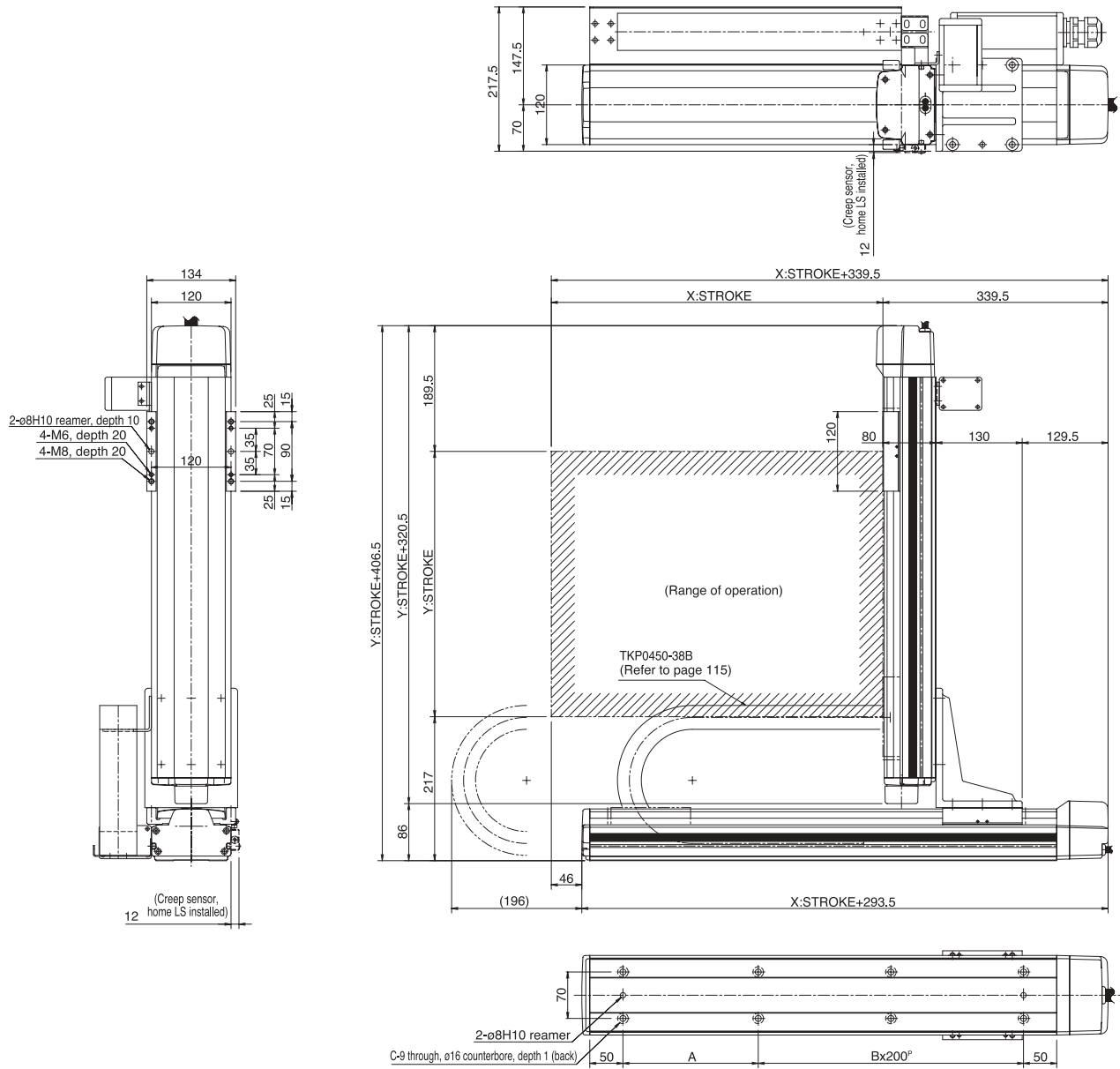

X stroke	200	300	400	500	600	700	800
A	104	204	104	204	104	204	104
B	1	1	2	2	3	3	4
C	6	6	8	8	10	10	12

ICSA2-Z2CH Cartesian Robot: X-Z 2-Axes Configuration, XZ (Z-Axis Base Mount) Type

ICSPA2-Z2CH Cartesian Robot: X-Z 2-Axes Configuration, XZ (Z-Axis Base Mount) Type High-Precision Specification

Type XZ type Stroke X-axis: 200-800mm Z-axis: 100-400mm Load capacity 19kg ~ 11kg

Model specification items Series Type Encoder type X-axis stroke + options Z-axis stroke + options Applicable controller Cable length Cable management
 ICSA 2-Z2CH - A - 80AQLNM - 40AQLB - T1 - 5L - CT



* Refer to page 61 for the details of model specification items.

Models/Specifications

Model	Axis configuration		Encoder type	Motor output (W)	Lead (mm)	Stroke (mm) In increments of 100mm	Speed (mm/s) (Note 1)	Load capacity (Note 2)	Positioning repeatability (mm) (Note 3)
ICSA2 [ICSPA2] -Z2CH-A-***-***-B-T1-△-CT	X-axis	ISA [ISPA] -MXM-A-200-20-***-T1	Absolute	200	20	200 ~ 800	1 ~ 1000	19 ~ 11	±0.02 [±0.01]
	Z-axis	ISA [ISPA] -MZM-A-200-10-***-T1-B			10	100 ~ 400	1 ~ 500		
ICSA2 [ICSPA2] -Z2CH-I-***-***-B-T1-△-CT	X-axis	ISA [ISPA] -MXM-I-200-20-***-T1	Incremental		20	200 ~ 800	1 ~ 1000		
	Z-axis	ISA [ISPA] -MZM-I-200-10-***-T1-B			10	100 ~ 400	1 ~ 500		

* In the above model names, *** indicates the stroke/applicable options (stroke is specified in centimeters), and △ the cable length.

Options

Name	Code	Page	Remarks
AQ seal	AQ	P13	
Brake	B	P13	Standard equipment on Z-axis
Creep sensor	C	P13	
Home limit switch	L	P14	
Reverse homing specification	NM	P14	
Guide with ball-retaining mechanism	RT	P14	

Common Specifications

Drive system (Note 4)	Ball screw, rolled C10 [equivalent to rolled C5]
Backlash (Note 5)	0.05mm or less [0.02mm or less]
Guide	Integrated with base
Base	Material: Aluminum with white alumite treatment
Cable length (Note 6)	3L: 3m, 5L: 5m, □L : Length specification
Cable management	CT: Cable track

Load Capacity by Acceleration (kg)

Acceleration (G)	Z-axis stroke (mm)			
	100	200	300	400
0.3	19.0	16.0	13.0	11.0
0.4	16.3	13.0	10.0	8.0
0.5	11.3	10.3	8.0	6.0
0.6				
0.7				
0.8				
0.9				
1.0				

Maximum Speed by Stroke (mm/sec)

Axis	Stroke (mm)			
	100	200 ~ 400	500 ~ 700	800
X-axis	-	1000		795
Z-axis	500		-	-

Applicable Controller Specifications

Applicable controller	Controller type	Model	Page
X-SEL	General-purpose type	XSEL-K-2-200□-200B□-□-□□□-□-□	
	Compact type	XSEL-J-2-200□-200B□-□-□□□-□-□	

Caution

(Note 1) The maximum speed will vary depending on the stroke. (Refer to the table of maximum speed by stroke.)
 (Note 2) The load capacity assumes operation at the rated acceleration (0.3 G). The actuator can be operated at accelerations beyond the rated acceleration, but the load capacity will decrease (refer to the table of load capacity by acceleration).
 (Notes 3, 4, 5) The figures in brackets apply to the ICSPA2.
 (Note 6) The cable length measures from the X-axis connector box to the controller. The standard lengths are 3 m and 5 m, but other lengths can also be specified in meters up to 20 m (e.g., 10L = 10 m).

* Refer to page 59 for other points to note.

Cable Track Specification (Cable Management Code: CT)

Dimensions

Single-Axis Robots
Cartesian Robots

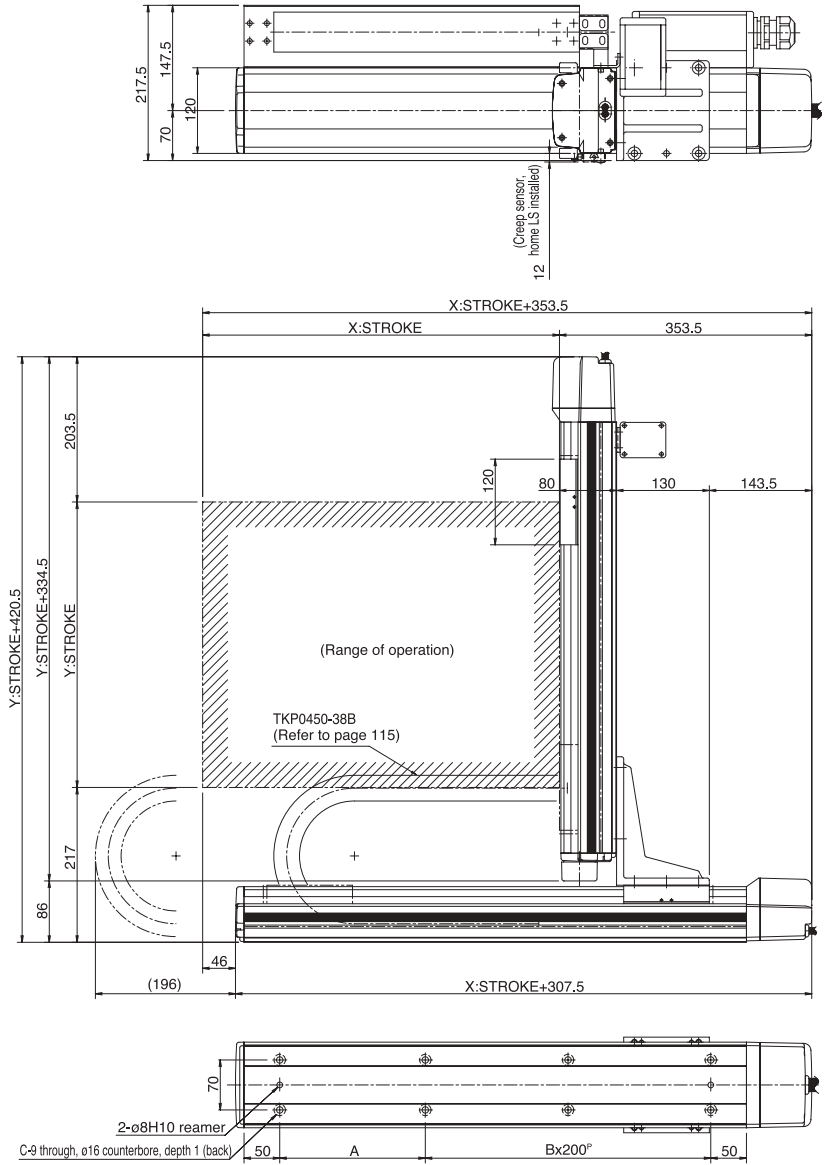
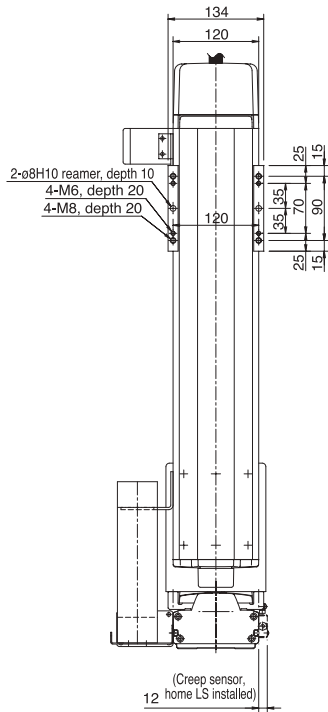

X stroke	200	300	400	500	600	700	800
A	104	204	104	204	104	204	104
B	1	1	2	2	3	3	4
C	6	6	8	8	10	10	12

Cable Track Specification (Cable Management Code: CT)

Dimensions

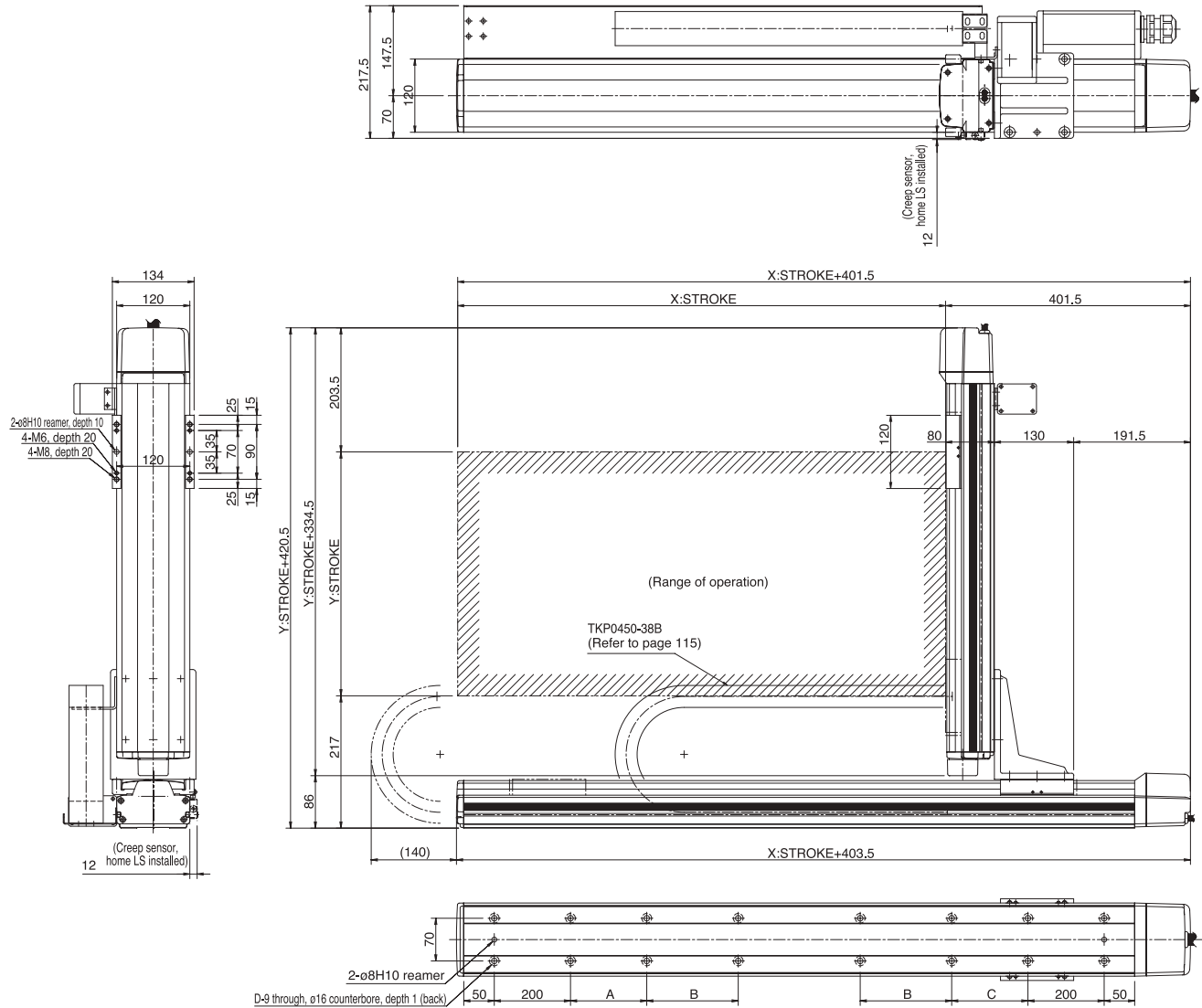

X stroke	800	900	1000	1100	1200	1300	1400	1500	1600	1700	1800	1900	2000
A	0	0	200	250	300	350	400	450	500	550	200	200	200
B	0	0	0	0	0	0	0	0	0	0	400	450	500
C	200	200	200	250	300	350	400	450	500	550	200	200	200
D	10	10	12	12	12	12	12	12	12	12	16	16	16

ICSA2-ZGH Cartesian Robot: X-Z 2-Axes Configuration, XZ (Z-Axis Base Mount) Type

ICSPA2-ZGH Cartesian Robot: X-Z 2-Axes Configuration, XZ (Z-Axis Base Mount) Type **High-Precision Specification**

Type **XZ type** Stroke X-axis: 200~800mm Z-axis: 100~500mm Load capacity **22kg ~ 10kg**

Model specification items Series Type Encoder type X-axis stroke + options Z-axis stroke + options Applicable controller Cable length Cable management

ICSA 2 – ZGH – A – 80AQLNM – 50AQB L – T1 – 5L – CT



* Refer to page 61 for the details of model specification items.

Models/Specifications

Model	Axis configuration		Encoder type	Motor output (W)	Lead (mm)	Stroke (mm) In increments of 100mm	Speed (mm/s)	Load capacity (Note 1)	Positioning repeatability (mm) (Note 2)
ICSA2 [ICSPA2] -ZGH-A-***-***-*** B-T1-△-CT	X-axis	ISA [ISPA] -LXM-A-400-20-***-T1	Absolute	400	20	200 ~ 800	1 ~ 1000	22 ~ 10	±0.02 [±0.01]
	Z-axis	ISA [ISPA] -LZM-A-400-10-***-T1-B			10	100 ~ 500	1 ~ 500		
ICSA2 [ICSPA2] -ZGH-I-***-***-*** B-T1-△-CT	X-axis	ISA [ISPA] -LXM-I-400-20-***-T1	Incremental		20	200 ~ 800	1 ~ 1000		
	Z-axis	ISA [ISPA] -LZM-I-400-10-***-T1-B			10	100 ~ 500	1 ~ 500		

* In the above model names, *** indicates the stroke/applicable options (stroke is specified in centimeters), and △ the cable length.

Options

Name	Code	Page	Remarks
AQ seal	AQ	P13	
Brake	B	P13	Standard equipment on Z-axis
Creep sensor	C	P13	
Home limit switch	L	P14	
Reverse homing specification	NM	P14	
Guide with ball-retaining mechanism	RT	P14	

Common Specifications

Drive system (Note 3)	Ball screw, rolled C10 [equivalent to rolled C5]
Backlash (Note 4)	0.05mm or less [0.02mm or less]
Guide	Integrated with base
Base	Material: Aluminum with white alumite treatment
Cable length (Note 5)	3L: 3m, 5L: 5m, □L : Length specification
Cable management	CT: Cable track

Load Capacity by Acceleration (kg)

Z-axis stroke (mm) / Acceleration (G)	100	200	300	400	500
0.3	22.0	18.0	16.0	12.0	10.0
0.4	20.0	16.0	12.0	9.0	6.0
0.5	16.0	12.0	9.0	6.0	3.0
0.6					
0.7					
0.8					
0.9					
1.0					

Maximum Speed by Stroke (mm/sec)

Stroke (mm)	100	200 ~ 500	600 ~ 800
X-axis	—	1000	
Z-axis	500		—

Applicable Controller Specifications

Applicable controller	Controller type	Model	Page
X-SEL	General-purpose type	XSEL-K-2-400□-400B□-□-□□□-□-□	
	Compact type	XSEL-J-2-400□-400B□-□-□□□-□-□	

Caution

(Note 1) The load capacity assumes operation at the rated acceleration (0.3 G). The actuator can be operated at accelerations beyond the rated acceleration, but the load capacity will decrease (refer to the table of load capacity by acceleration).

(Notes 2, 3, 4) The figures in brackets apply to the ICSPA2.

(Note 5) The cable length measures from the X-axis connector box to the controller. The standard lengths are 3 m and 5 m, but other lengths can also be specified in meters up to 20 m (e.g., 10L = 10 m).

* Refer to page 59 for other points to note.

Cable Track Specification (Cable Management Code: CT)

Dimensions

Single-Axis Robots
Cartesian Robots

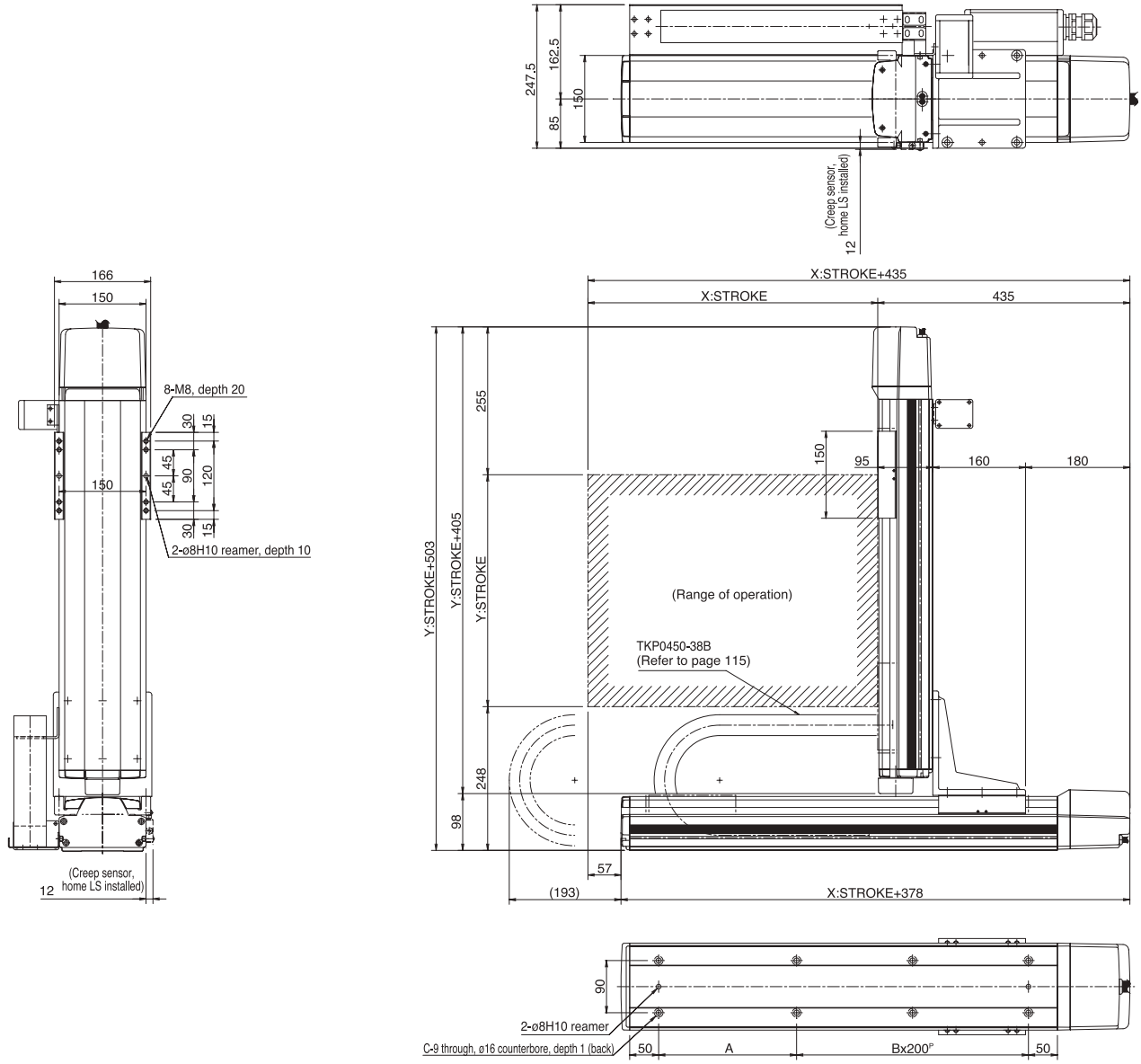

X stroke	200	300	400	500	600	700	800
A	138	238	138	238	138	238	138
B	1	1	2	2	3	3	4
C	6	6	8	8	10	10	12

ICSA2-ZHH Cartesian Robot: X-Z 2-Axes Configuration, XZ (Z-Axis Base Mount) Type

ICSPA2-ZHH Cartesian Robot: X-Z 2-Axes Configuration, XZ (Z-Axis Base Mount) Type **High-Precision Specification**



Type XZ type Stroke X-axis: 1000~2500mm Z-axis: 100~500mm Load capacity 22kg ~ 10kg

Model specification items Series Type Encoder type X-axis stroke + options Z-axis stroke + options Applicable controller Cable length Cable management
 ICSA 2-ZHH - A - 250AQLNM - 50AQL - T1 - 5L - CT

* Refer to page 61 for the details of model specification items.

Models/Specifications

Model	Axis configuration	Encoder type	Motor output (W)	Lead (mm)	Stroke (mm) In increments of 100mm	Speed (mm/s) (Note 1)	Load capacity (Note 2)	Positioning repeatability (mm) (Note 3)
ICSA2 [ICSPA2] -ZHH-A-***-***-B-T1-△-CT	X-axis ISA [ISPA] -LXM-A-400-20-***-T1	Absolute	400	20	1000 ~ 2500	1 ~ 1000	22 ~ 10	±0.02 [±0.01]
	Z-axis ISA [ISPA] -LZM-A-400-10-***-T1-B			10	100 ~ 500	1 ~ 500		
ICSA2 [ICSPA2] -ZHH-I-***-***-B-T1-△-CT	X-axis ISA [ISPA] -LXM-I-400-20-***-T1	Incremental		20	1000 ~ 2500	1 ~ 1000		
	Z-axis ISA [ISPA] -LZM-I-400-10-***-T1-B			10	100 ~ 500	1 ~ 500		

* In the above model names, *** indicates the stroke/applicable options (stroke is specified in centimeters), and △ the cable length.

Options

Name	Code	Page	Remarks
AQ seal	AQ	P13	
Brake	B	P13	Standard equipment on Z-axis
Creep sensor	C	P13	
Home limit switch	L	P14	
Reverse homing specification	NM	P14	
Guide with ball-retaining mechanism	RT	P14	

Common Specifications

Drive system (Note 4)	Ball screw, rolled C10 [equivalent to rolled C5]
Backlash (Note 5)	0.05mm or less [0.02mm or less]
Guide	Integrated with base
Base	Material: Aluminum with white alumite treatment
Cable length (Note 6)	3L: 3m, 5L: 5m, □L : Length specification
Cable management	CT: Cable track

Load Capacity by Acceleration (kg)

Z-axis stroke (mm)	100	200	300	400	500
Acceleration (G)					
0.3	22.0	18.0	16.0	12.0	10.0
0.4					
0.5					
0.6					
0.7					
0.8					
0.9					
1.0					

Maximum Speed by Stroke (mm/sec)

Stroke (mm)	100 ~ 500	1000 ~ 1400	1500	1600	1700	1800	1900	2000	2500
X-axis	-	1000	950	830	740	650	590	540	340
Z-axis	500	-	-	-	-	-	-	-	-

Applicable Controller Specifications

Applicable controller	Controller type	Model	Page
X-SEL	General-purpose type	XSEL-K-2-400□-400B□-□-□□□-□-□	
	Compact type	XSEL-J-2-400□-400B□-□-□□□-□-□	

Caution

(Note 1) The maximum speed will vary depending on the stroke. (Refer to the table of maximum speed by stroke.)

(Note 2) The load capacity assumes operation at the rated acceleration (0.3 G). The rated acceleration is the maximum specifiable acceleration for both the ICSA2 and ICSPA2.

(Notes 3, 4, 5) The figures in brackets apply to the ICSPA2.

(Note 6) The cable length measures from the X-axis connector box to the controller. The standard lengths are 3 m and 5 m, but other lengths can also be specified in meters up to 20 m (e.g., 10L = 10 m).

* Refer to page 49 for other points to note.

Self-standing Cable Specification (Cable Management Code: CT)

Dimensions

Single-Axis Robots
Cartesian Robots

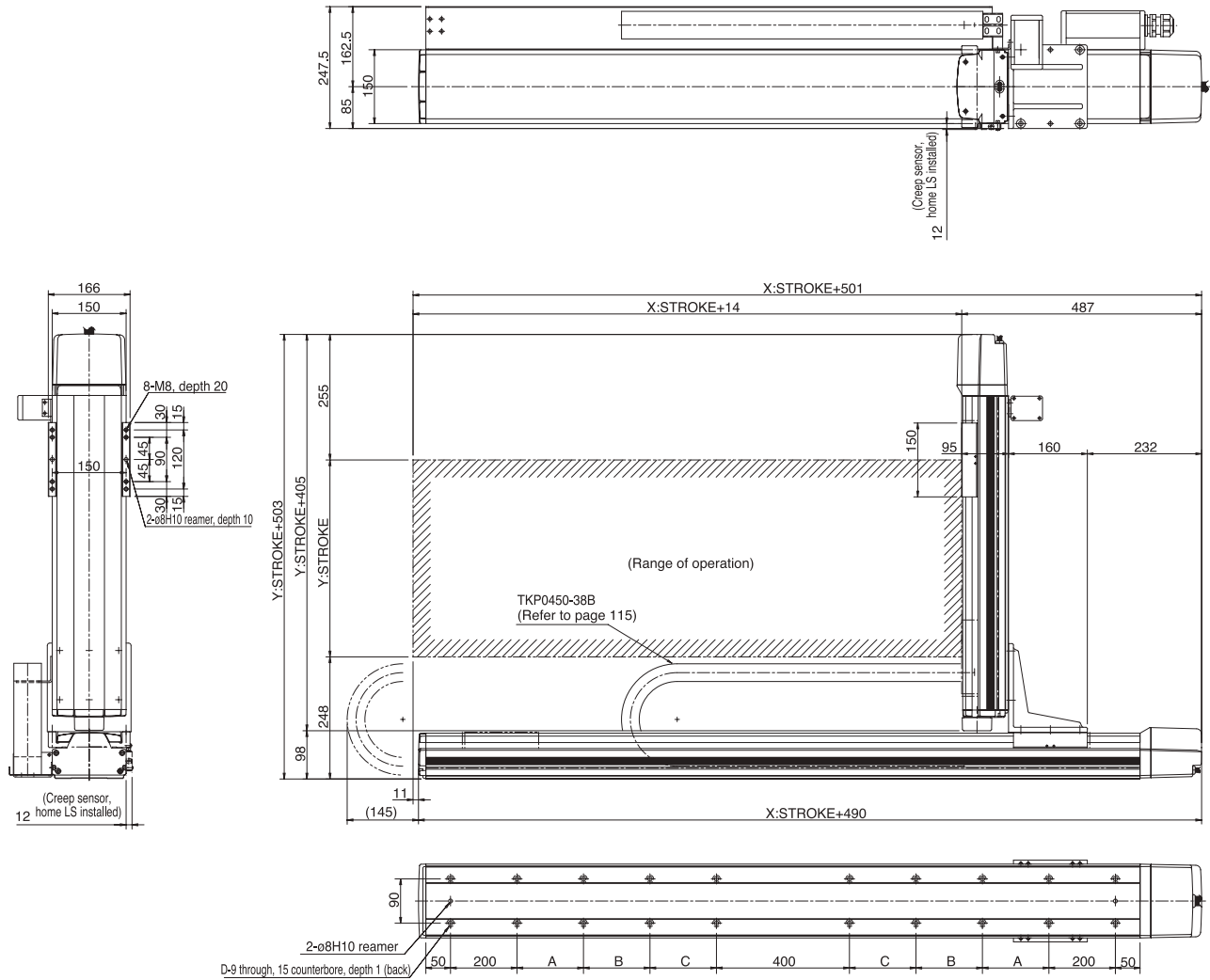

X stroke	1000	1100	1200	1300	1400	1500	1600	1700	1800	1900	2000	2100	2200	2300	2400	2500
A	225	275	325	375	425	475	525	575	200	200	200	200	200	200	200	200
B	0	0	0	0	0	0	0	0	425	475	525	575	200	200	200	200
C	0	0	0	0	0	0	0	0	0	0	0	0	425	475	525	575
D	12	12	12	12	12	12	12	12	16	16	16	16	20	20	20	20

ICSA2-YAH Cartesian Robot: Y-Z 2-Axes Configuration, YZ (Z-Axis Slider Mount) Type

ICSPA2-YAH Cartesian Robot: Y-Z 2-Axes Configuration, YZ (Z-Axis Slider Mount) Type **High-Precision Specification**

Type **YZ type** Stroke Y-axis: 100~400mm Z-axis: 100~300mm Load capacity **3kg ~ 1.6kg**

Model specification items Series **ICSA2** - Type **YAH** - Encoder type **A** - Y-axis stroke + options **40AQLNM** - Z-axis stroke + options **30AQB** - Applicable controller **T1** - Cable length **5L** - Cable management **SC**



* Refer to page 61 for the details of model specification items.

Models/Specifications

Model	Axis configuration		Encoder type	Motor output (W)	Lead (mm)	Stroke (mm) In increments of 100mm	Speed (mm/s)	Load capacity (Note 1)	Positioning repeatability (mm) (Note 2)
ICSA2 [ICSPA2] -YAH-A-***-***-B-T1-△-SC	Y-axis	ISA [ISPA] -SYM-A-60-16-***-T1	Absolute	60	16	100 ~ 400	1 ~ 800	3 ~ 1.6	±0.02 [±0.01]
	Z-axis	ISA [ISPA] -SZM-A-60-8-***-T1-B			8	100 ~ 300	1 ~ 400		
ICSA2 [ICSPA2] -YAH-I-***-***-B-T1-△-SC	Y-axis	ISA [ISPA] -SYM-A-60-16-***-T1	Incremental		16	100 ~ 400	1 ~ 800		
	Z-axis	ISA [ISPA] -SZM-A-60-8-***-T1-B			8	100 ~ 300	1 ~ 400		

* In the above model names, *** indicates the stroke/applicable options (stroke is specified in centimeters), and △ the cable length.

Options

Name	Code	Page	Remarks
AQ seal	AQ	P13	
Brake	B	P13	Standard equipment on Z-axis
Creep sensor	C	P13	
Home limit switch	L	P14	
Reverse homing specification	NM	P14	
Guide with ball-retaining mechanism	RT	P14	

Common Specifications

Drive system (Note 3)	Ball screw, rolled C10 [equivalent to rolled C5]
Backlash (Note 4)	0.05mm or less [0.02mm or less]
Guide	Integrated with base
Base	Material: Aluminum with white alumite treatment
Cable length (Note 5)	3L: 3m, 5L: 5m, □L : Length specification
Cable management	SC: Self-standing cable

Load Capacity by Acceleration (kg)

Z-axis stroke (mm) \ Acceleration (G)	100	200	300
0.3	3.0	2.3	1.6
0.4	2.5	1.8	1.1
0.5	1.0	0.3	
0.6			
0.7			
0.8			
0.9			
1.0			

Maximum Speed by Stroke (mm/sec)

Axis \ Stroke (mm)	100 ~ 300	400
Y-axis	800	
Z-axis	400	-

Applicable Controller Specifications

Applicable controller	Controller type	Model	Page
X-SEL	General-purpose type	XSEL-K-2-60 □-60B□-□-□□□-□-□	
	Compact type	XSEL-J-2-60 □-60B□-□-□□□-□-□	

Caution

(Note 1) The load capacity assumes operation at the rated acceleration (0.3 G). The actuator can be operated at accelerations beyond the rated acceleration, but the load capacity will decrease (refer to the table of load capacity by acceleration).

(Notes 2, 3, 4) The figures in brackets apply to the ICSPA2.

(Note 5) The cable length measures from the X-axis connector box to the controller. The standard lengths are 3 m and 5 m, but other lengths can also be specified in meters up to 20 m (e.g., 10L = 10 m).

* Refer to page 59 for other points to note.

Self-standing Cable Specification (Cable Management Code: SC)

Dimensions

* Note that changing the home direction will require the actuator to be returned to IAI for adjustment.

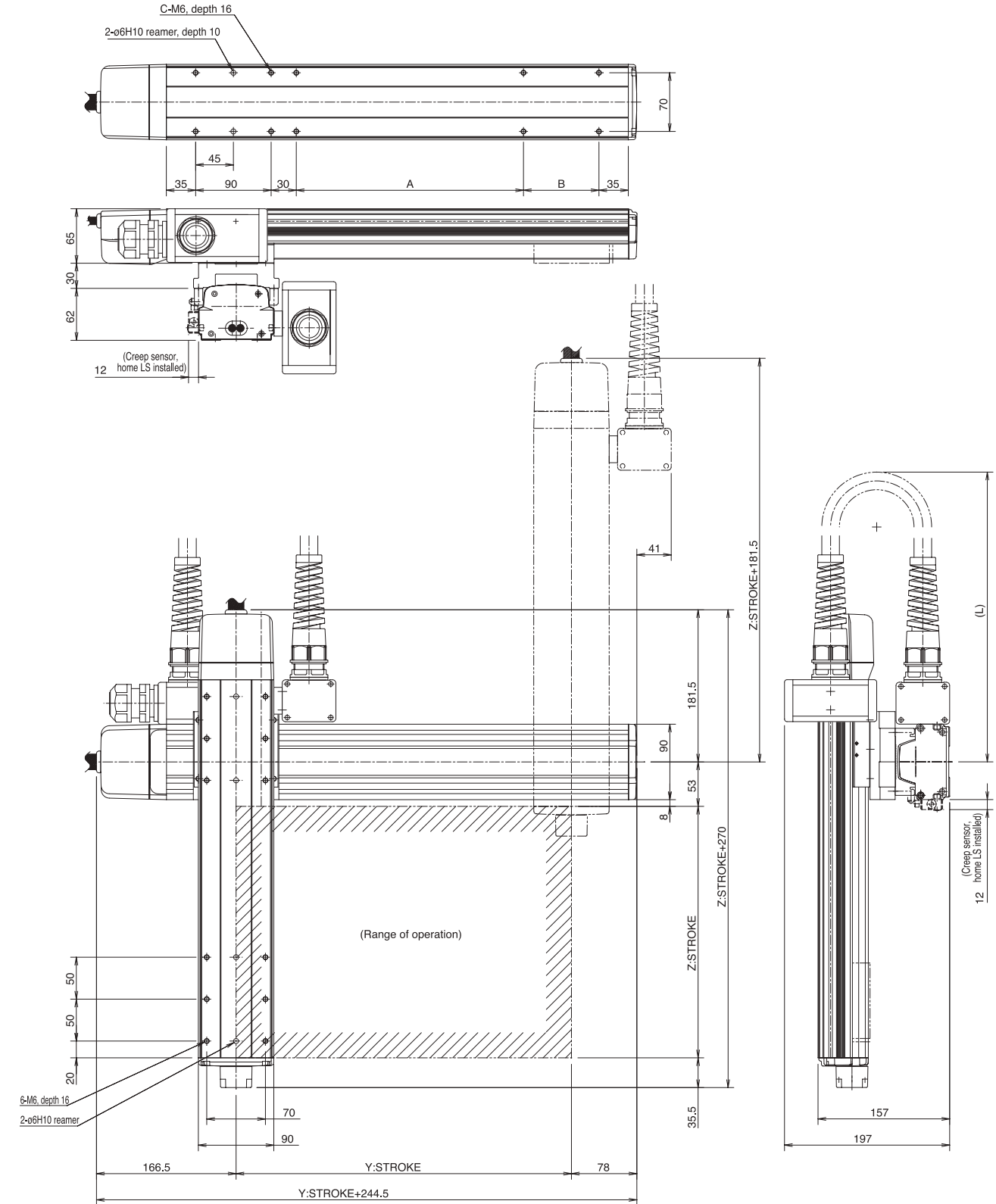

Dimension L				
Zst \ Yst	100	200	300	400
100	450	500	550	600
200	550	600	650	700
300	650	700	750	800

Y stroke	100	200	300	400
A	61	71	171	271
B	-	90	90	90
C	8	10	10	10

Single-Axis Robots
Cartesian Robots

ICSA2-YAM Cartesian Robot: Y-Z 2-Axes Configuration, YZ (Z-Axis Slider Mount) Type

ICSPA2-YAM Cartesian Robot: Y-Z 2-Axes Configuration, YZ (Z-Axis Slider Mount) Type **High-Precision Specification**

Type YZ type Stroke Y-axis: 100~400mm Z-axis: 100~300mm Load capacity 11kg ~ 9.6kg

Model specification items Series Type Encoder type Y-axis stroke + options Z-axis stroke + options Applicable controller Cable length Cable management
ICSA2 - YAM - A - 40AQLNM - 30AQB - T1 - 5L - SC



* Refer to page 61 for the details of model specification items.

Models/Specifications

Model	Axis configuration		Encoder type	Motor output (W)	Lead (mm)	Stroke (mm) In increments of 100mm	Speed (mm/s)	Load capacity (Note 1)	Positioning repeatability (mm) (Note 2)
ICSA2 [ICSPA2] -YAM-A-***-***-B-T1-△-SC	Y-axis	ISA [ISPA] -SYM-A-60-8-***-T1	Absolute	60	8	100 ~ 400	1 ~ 400	11 ~ 9.6	±0.02 [±0.01]
	Z-axis	ISA [ISPA] -SZM-A-60-4-***-T1-B			4	100 ~ 300	1 ~ 200		
ICSA2 [ICSPA2] -YAM-I-***-***-B-T1-△-SC	Y-axis	ISA [ISPA] -SYM-I-60-8-***-T1	Incremental		8	100 ~ 400	1 ~ 400		
	Z-axis	ISA [ISPA] -SZM-I-60-4-***-T1-B			4	100 ~ 300	1 ~ 200		

* In the above model names, *** indicates the stroke/applicable options (stroke is specified in centimeters), and △ the cable length.

Options

Name	Code	Page	Remarks
AQ seal	AQ	P13	
Brake	B	P13	Standard equipment on Z-axis
Creep sensor	C	P13	
Home limit switch	L	P14	
Reverse homing specification	NM	P14	
Guide with ball-retaining mechanism	RT	P14	

Common Specifications

Drive system (Note 3)	Ball screw, rolled C10 [equivalent to rolled C5]
Backlash (Note 4)	0.05mm or less [0.02mm or less]
Guide	Integrated with base
Base	Material: Aluminum with white alumite treatment
Cable length (Note 5)	3L: 3m, 5L: 5m, □L : Length specification
Cable management	SC: Self-standing cable

Load Capacity by Acceleration (kg)

Z-axis stroke (mm) / Acceleration (G)	100	200	300
0.3	11.0	10.3	9.6
0.4	11.0	10.3	9.6
0.5	9.0	8.3	7.6
0.6	6.0	5.3	4.6
0.7			
0.8			
0.9			
1.0			

* Assuming operation of the Z axis at its rated acceleration of 0.15 G, the load capacity varies according to the changes in acceleration of the X axis.

Maximum Speed by Stroke (mm/sec)

Stroke (mm) / Axis	100 ~ 300	400
Y-axis	400	
Z-axis	200	-

Applicable Controller Specifications

Applicable controller	Controller type	Model	Page
X-SEL	General-purpose type	XSEL-K-2-60□-60B□-□-□□□-□-□	
	Compact type	XSEL-J-2-60□-60B□-□-□□□-□-□	

Caution

(Note 1) The load capacity assumes operation at the rated acceleration (0.3 G for the Y-axis, 0.15 G for the Z-axis). The actuator can be operated at accelerations beyond the rated acceleration, but the load capacity will decrease (refer to the table of load capacity by acceleration).
 (Notes 2, 3, 4) The figures in brackets apply to the ICSPA2.
 (Note 5) The cable length measures from the X-axis connector box to the controller. The standard lengths are 3 m and 5 m, but other lengths can also be specified in meters up to 20 m (e.g., 10L = 10 m).

* Refer to page 59 for other points to note.

Self-standing Cable Specification (Cable Management Code: SC)

Dimensions

* Note that changing the home direction will require the actuator to be returned to IAI for adjustment.

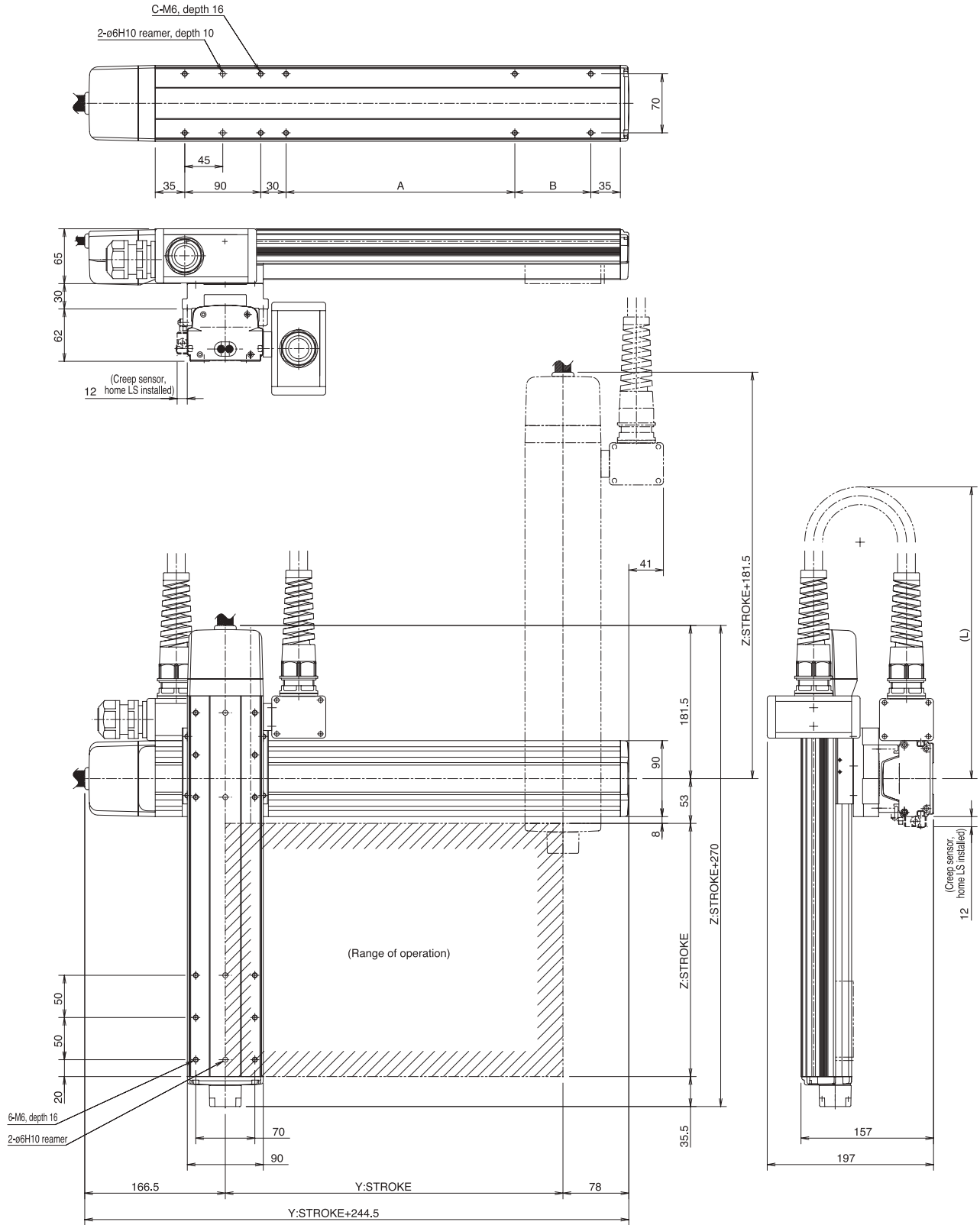

Dimension L				
Zst \ Yst	100	200	300	400
100	450	500	550	600
200	550	600	650	700
300	650	700	750	800

Y stroke	100	200	300	400
A	61	71	171	271
B	-	90	90	90
C	8	10	10	10

Single-Axis Robots
Cartesian Robots

ICSA2-YCH

Cartesian Robot: Y-Z 2-Axes Configuration, YZ (Z-Axis Slider Mount) Type

ICSPA2-YCH

Cartesian Robot: Y-Z 2-Axes Configuration, YZ (Z-Axis Slider Mount) Type **High-Precision Specification**



Type **YZ type** Stroke Y-axis: 200~700mm Z-axis: 100~400mm Load capacity **11.9kg ~ 8.9kg**

Model specification items Series **ICSA2** - Type **-YCH** - Encoder type **A** - Y-axis stroke + options **70AQLNM** - Z-axis stroke + options **40AQB** - Applicable controller **T1** - Cable length **5L** - Cable management **SC**

* Refer to page 61 for the details of model specification items.

Models/Specifications

Model	Axis configuration		Encoder type	Motor output (W)	Lead (mm)	Stroke (mm) In increments of 100mm	Speed (mm/s)	Load capacity (Note 1)	Positioning repeatability (mm) (Note 2)
ICSA2 [ICSPA2] -YCH-A-***-***-B-T1-△-SC	Y-axis	ISA [ISPA]-MYM-A-200-20-***-T1	Absolute	200	20	200 ~ 700	1 ~ 1000	11.9 ~ 8.9	±0.02 [±0.01]
	Z-axis	ISA [ISPA]-MZM-A-200-20-***-T1-B			10	100 ~ 400	1 ~ 500		
ICSA2 [ICSPA2] -YCH-I-***-***-B-T1-△-SC	Y-axis	ISA [ISPA]-MYM-I-200-20-***-T1	Incremental		20	200 ~ 700	1 ~ 1000		
	Z-axis	ISA [ISPA]-MZM-I-200-20-***-T1-B			10	100 ~ 400	1 ~ 500		

* In the above model names, *** indicates the stroke/applicable options (stroke is specified in centimeters), and △ the cable length.

Options

Name	Code	Page	Remarks
AQ seal	AQ	P13	
Brake	B	P13	Standard equipment on Z-axis
Creep sensor	C	P13	
Home limit switch	L	P14	
Reverse homing specification	NM	P14	
Guide with ball-retaining mechanism	RT	P14	

Common Specifications

Drive system (Note 3)	Ball screw, rolled C10 [equivalent to rolled C5]
Backlash (Note 4)	0.05mm or less [0.02mm or less]
Guide	Integrated with base
Base	Material: Aluminum with white alumite treatment
Cable length (Note 5)	3L: 3m, 5L: 5m, □L : Length specification
Cable management	SC: Self-standing cable

Load Capacity by Acceleration (kg)

Z-axis stroke (mm) / Acceleration (G)	100	200	300	400
0.3	11.9	10.9	9.9	8.9
0.4	9.2	8.2	7.2	6.2
0.5	7.9	6.9	5.9	4.9
0.6				
0.7				
0.8				
0.9				
1.0				

Maximum Speed by Stroke (mm/sec)

Stroke (mm) / Axis	100	200 ~ 400	500 ~ 700
Y-axis	-	1000	
Z-axis	500		-

Applicable Controller Specifications

Applicable controller	Controller type	Model	Page
X-SEL	General-purpose type	XSEL-K-2-200□-200B□-□-□□□-□-□	
	Compact type	XSEL-J-2-200□-200B□-□-□□□-□-□	

Caution

(Note 1) The load capacity assumes operation at the rated acceleration (0.3 G). The actuator can be operated at accelerations beyond the rated acceleration, but the load capacity will decrease (refer to the table of load capacity by acceleration).

(Notes 2, 3, 4) The figures in brackets apply to the ICSPA2.

(Note 5) The cable length measures from the X-axis connector box to the controller. The standard lengths are 3 m and 5 m, but other lengths can also be specified in meters up to 20 m (e.g., 10L = 10 m).

* Refer to page 59 for other points to note.

Self-standing Cable Specification (Cable Management Code: SC)

Dimensions

* Note that changing the home direction will require the actuator to be returned to IAI for adjustment.

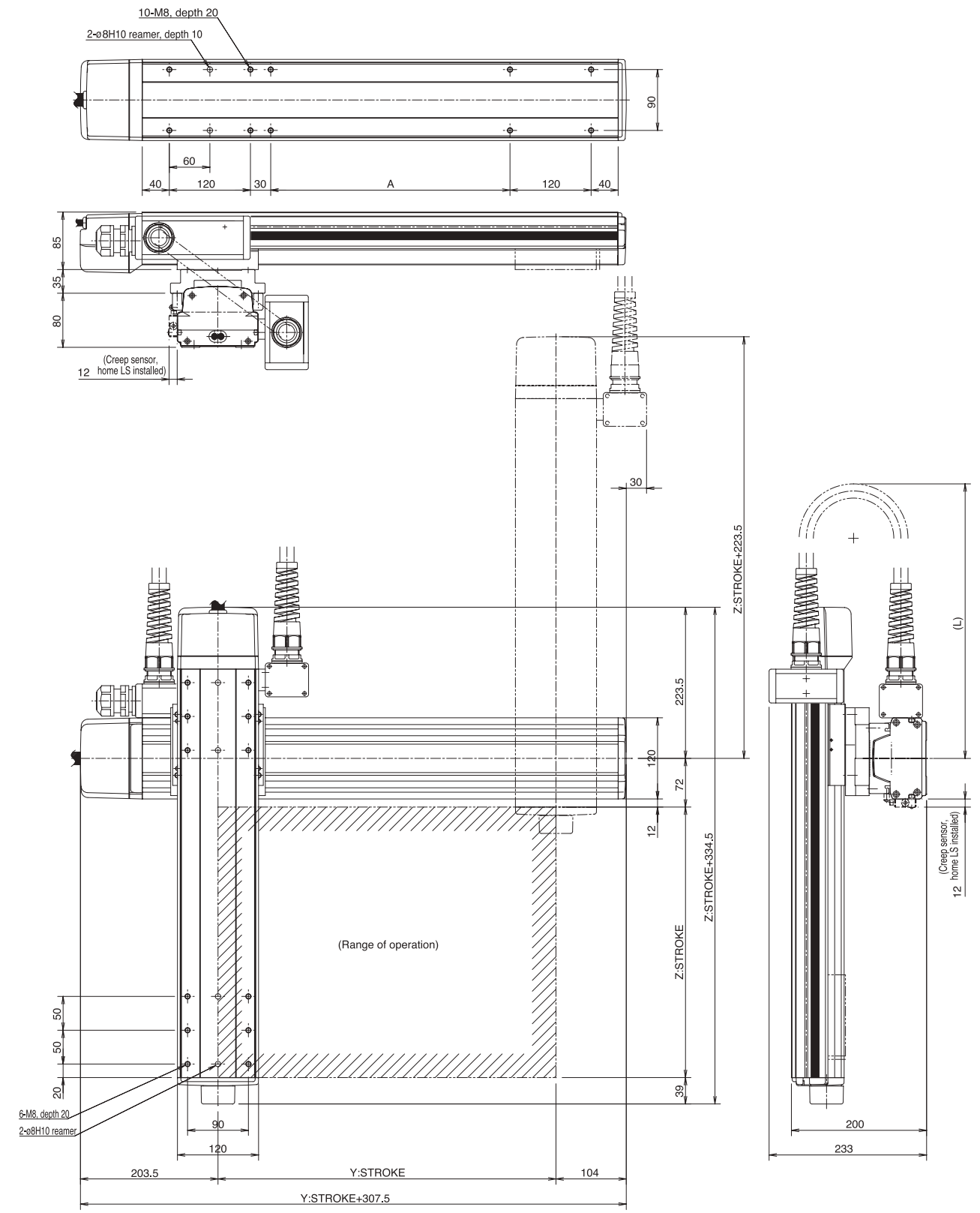

		Dimension L					
Zst \ Yst	200	300	400	500	600	700	
100	500	550	600	650	700	750	
200	600	650	700	750	800	850	
300	700	750	800	850	900	950	
400	800	850	900	950	1000	1050	
Y stroke	200	300	400	500	600	700	
A	404	504	604	704	804	904	

Single-Axis Robots
Cartesian Robots

ICSA2-YCM Cartesian Robot: Y-Z 2-Axes Configuration, YZ (Z-Axis Slider Mount) Type
ICSPA2-YCM Cartesian Robot: Y-Z 2-Axes Configuration, YZ (Z-Axis Slider Mount) Type **High-Precision Specification**



Type	YZ type	Stroke	Y-axis: 200~700mm Z-axis: 100~400mm	Load capacity	13.1kg ~ 10.1kg			
Model specification items	Series	Type	Encoder type	Y-axis stroke + options	Z-axis stroke + options	Applicable controller	Cable length	Cable management
	ICSA2	-YCM	-A	-70AQLNM	-40AQL	-T1	-5L	-SC

* Refer to page 61 for the details of model specification items.

Models/Specifications

Model	Axis configuration	Encoder type	Motor output (W)	Lead (mm)	Stroke (mm) In increments of 100mm	Speed (mm/s) (Note 1)	Load capacity (Note 2)	Positioning repeatability (mm) (Note 3)
ICSA2 [ICSPA2] -YCM-A-***-***-B-T1-△-SC	Y-axis	Absolute	100	10	200 ~ 700	1 ~ 500	13.1 ~ 10.1	±0.02 [±0.01]
	Z-axis			5	100 ~ 400	1 ~ 250		
ICSA2 [ICSPA2] -YCM-I-***-***-B-T1-△-SC	Y-axis	Incremental		10	200 ~ 700	1 ~ 500		
	Z-axis			5	100 ~ 400	1 ~ 250		

* In the above model names, *** indicates the stroke/applicable options (stroke is specified in centimeters), and △ the cable length.

Options

Name	Code	Page	Remarks
AQ seal	AQ	P13	
Brake	B	P13	Standard equipment on Z-axis
Creep sensor	C	P13	
Home limit switch	L	P14	
Reverse homing specification	NM	P14	
Guide with ball-retaining mechanism	RT	P14	

Common Specifications

Drive system (Note 4)	Ball screw, rolled C10 [equivalent to rolled C5]
Backlash (Note 5)	0.05mm or less [0.02mm or less]
Guide	Integrated with base
Base	Material: Aluminum with white alumite treatment
Cable length (Note 6)	3L: 3m, 5L: 5m, □L : Length specification
Cable management	SC: Self-standing cable

Load Capacity by Acceleration (kg)

Z-axis stroke (mm)	100	200	300	400
Acceleration (G)				
0.3	13.1	12.1	11.1	10.1
0.4	13.1	12.1	11.1	10.1
0.5	13.1	12.1	11.1	10.1
0.6	10.1	9.1	8.1	7.1
0.7				
0.8				
0.9				
1.0				

* Assuming operation of the Z axis at its rated acceleration of 0.15 G, the load capacity varies according to the changes in acceleration of the X axis.

Maximum Speed by Stroke (mm/sec)

Stroke (mm)	100	200 ~ 400	500 ~ 600	700
Axis				
Y-axis	-	500		480
Z-axis	250		-	

Applicable Controller Specifications

Applicable controller	Controller type	Model	Page
X-SEL	General-purpose type	XSEL-K-2-100□-100B□-□-□□□-□-□	
	Compact type	XSEL-J-2-100□-100B□-□-□□□-□-□	

Caution

(Note 1) The maximum speed will vary depending on the stroke. (Refer to the table of maximum speed by stroke.)
 (Note 2) The load capacity assumes operation at the rated acceleration (0.3 G for the Y-axis, 0.15 G for the Z-axis). The actuator can be operated at accelerations beyond the rated acceleration, but the load capacity will decrease (refer to the table of load capacity by acceleration).
 (Notes 3, 4, 5) The figures in brackets apply to the ICSPA2.
 (Note 6) The cable length measures from the Y-axis connector box to the controller. The standard lengths are 3 m and 5 m, but other lengths can also be specified in meters up to 20 m (e.g., 10L = 10 m).

* Refer to page 59 for other points to note.

Self-standing Cable Specification (Cable Management Code: SC)

Dimensions

* Note that changing the home direction will require the actuator to be returned to IAI for adjustment.

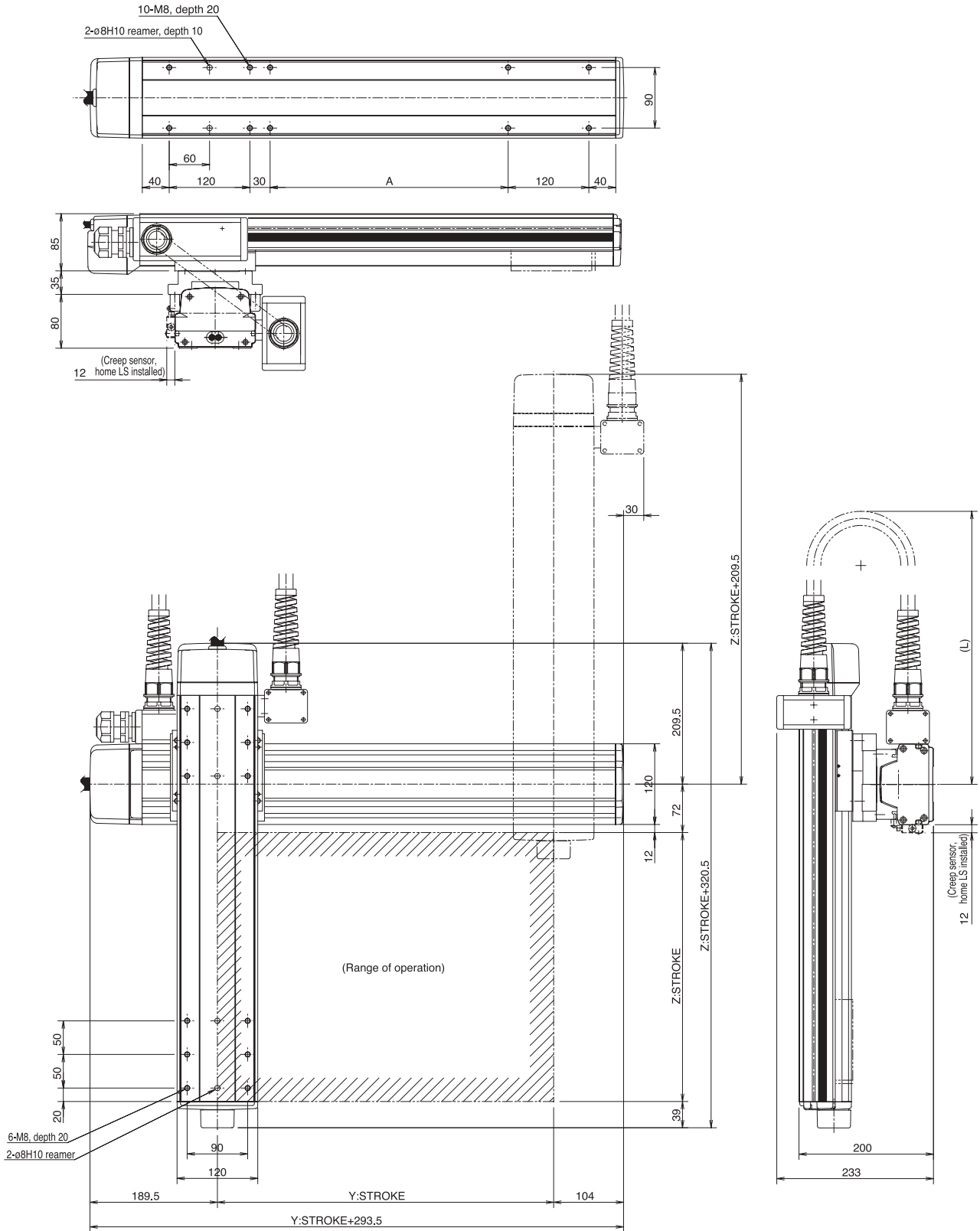

		Dimension L					
Zst \ Yst	200	300	400	500	600	700	
100	500	550	600	650	700	750	
200	600	650	700	750	800	850	
300	700	750	800	850	900	950	
400	800	850	900	950	1000	1050	

Y stroke	200	300	400	500	600	700
A	404	504	604	704	804	904

ICSA2-YGH Cartesian Robot: Y-Z 2-Axes Configuration, YZ (Z-Axis Slider Mount) Type

ICSPA2-YGH Cartesian Robot: Y-Z 2-Axes Configuration, YZ (Z-Axis Slider Mount) Type **High-Precision Specification**

Type YZ type Stroke Y-axis: 200~700mm Z-axis: 100~500mm Load capacity 27kg ~ 20.7kg

Model specification items Series Type Encoder type Y-axis stroke + options Z-axis stroke + options Applicable controller Cable length Cable management
ICSA2 - YCH - A - 70AQLNM - 50AQL - T1 - 5L - SC



* Refer to page 61 for the details of model specification items.

Models/Specifications

Model	Axis configuration		Encoder type	Motor output (W)	Lead (mm)	Stroke (mm) In increments of 100mm	Speed (mm/s)	Load capacity (Note 1)	Positioning repeatability (mm) (Note 2)
ICSA2 [ICSPA2] -YGH-A-***-***-B-T1-△-SC	Y-axis	ISA [ISPA] -LYM-A-400-20-***-T1	Absolute	400	20	200 ~ 700	1 ~ 1000	27 ~ 20.7	±0.02 [±0.01]
	Z-axis	ISA [ISPA] -LZM-A-400-10-***-T1-B			10	100 ~ 500	1 ~ 500		
ICSA2 [ICSPA2] -YGH-I-***-***-B-T1-△-SC	Y-axis	ISA [ISPA] -LYM-A-400-20-***-T1	Incremental		20	200 ~ 700	1 ~ 1000		
	Z-axis	ISA [ISPA] -LZM-A-400-10-***-T1-B			10	100 ~ 500	1 ~ 500		

* In the above model names, *** indicates the stroke/applicable options (stroke is specified in centimeters), and △ the cable length.

Options

Name	Code	Page	Remarks
AQ seal	AQ	P13	
Brake	B	P13	Standard equipment on Z-axis
Creep sensor	C	P13	
Home limit switch	L	P14	
Reverse homing specification	NM	P14	
Guide with ball-retaining mechanism	RT	P14	

Common Specifications

Drive system (Note 3)	Ball screw, rolled C10 [equivalent to rolled C5]
Backlash (Note 4)	0.05mm or less [0.02mm or less]
Guide	Integrated with base
Base	Material: Aluminum with white alumite treatment
Cable length (Note 5)	3L: 3m, 5L: 5m, □ L : Length specification
Cable management	SC: Self-standing cable

Load Capacity by Acceleration (kg)

Z-axis stroke (mm) / Acceleration (G)	100	200	300	400	500
0.3	27.0	25.5	23.9	22.3	20.7
0.4	20.1	18.6	17.0	15.4	13.8
0.5	15.6	14.1	12.5	10.9	9.3
0.6					
0.7					
0.8					
0.9					
1.0					

Maximum Speed by Stroke (mm/sec)

Stroke (mm) / Axis	100	200~500	600~700
Y-axis	-	1000	
Z-axis	500		-

Applicable Controller Specifications

Applicable controller	Controller type	Model	Page
X-SEL	General-purpose type	XSEL-K-2-400□-400B□-□-□□□-□-□	
	Compact type	XSEL-J-2-400□-400B□-□-□□□-□-□	

Caution

(Note 1) The load capacity assumes operation at the rated acceleration (0.3 G). The actuator can be operated at accelerations beyond the rated acceleration, but the load capacity will decrease (refer to the table of load capacity by acceleration).

(Notes 2, 3, 4) The figures in brackets apply to the ICSPA2.

(Note 5) The cable length measures from the X-axis connector box to the controller. The standard lengths are 3 m and 5 m, but other lengths can also be specified in meters up to 20 m (e.g., 10L = 10 m).

* Refer to page 59 for other points to note.

Self-standing Cable Specification (Cable Management Code: SC)

Dimensions

* Note that changing the home direction will require the actuator to be returned to IAI for adjustment.

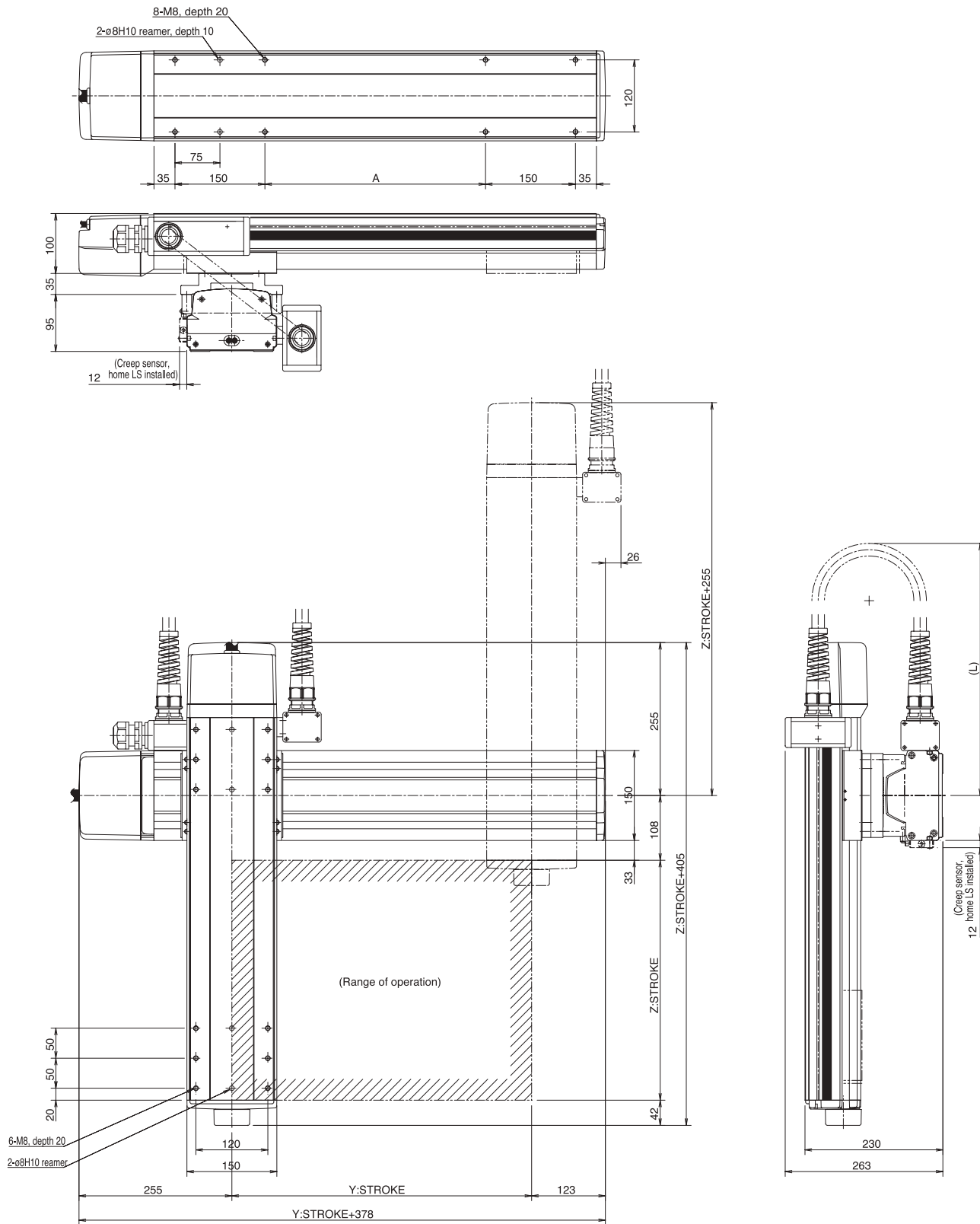

Dimension L							
Zst \ Yst	200	300	400	500	600	700	
100	500	550	600	650	700	750	
200	600	650	700	750	800	850	
300	700	750	800	850	900	950	
400	800	850	900	950	1000	1050	
500	900	950	1000	1050	1100	1150	

Y stroke	200	300	400	500	600	700
A	438	538	638	738	838	938

ICSA2-G1JH Cartesian Robot: X-Y 2-Axes Configuration, XYG (Y-Axis Gantry) Type

ICSPA2-G1JH Cartesian Robot: X-Y 2-Axes Configuration, XYG (Y-Axis Gantry) Type **High-Precision Specification**

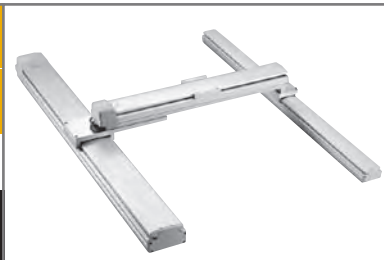

Type: XYG type Stroke: X-axis: 1000~2500mm Y-axis: 500~700mm Load capacity: 40kg

Model specification items: Series: ICSA 2 - G1JH - A - 250AQLNM - 70AQLB - T1 - 5L - CT

* Refer to page 61 for the details of model specification items.

Models/Specifications

Model	Axis configuration		Encoder type	Motor output (W)	Lead (mm)	Stroke (mm) In increments of 100mm	Speed (mm/s) (Note 1)	Load capacity (Note 2)	Positioning repeatability (mm) (Note 3)
ICSA2 [ICSPA2] -G1JH-A-***-***-T1-△-CT	X-axis	ISA [ISPA] -LXUWX-A-400-20-***-T1	Absolute	400	20	1000 ~ 2500	1 ~ 1000	40	±0.02 [±0.01]
	Y-axis	ISA [ISPA] -MXM-A-200-20-***-T1		200		500 ~ 700			
ICSA2 [ICSPA2] -G1JH-I-***-***-T1-△-CT	X-axis	ISA [ISPA] -LXUWX-I-400-20-***-T1	Incremental	400		1000 ~ 2500			
	Y-axis	ISA [ISPA] -MXM-I-200-20-***-T1		200		500 ~ 700			

* In the above model names, *** indicates the stroke/applicable options (stroke is specified in centimeters), and △ the cable length.

Options

Name	Code	Page	Remarks
AQ seal	AQ	P13	
Brake	B	P13	
Creep sensor	C	P13	
Home limit switch	L	P14	
Reverse homing specification	NM	P14	
Guide with ball-retaining mechanism	RT	P14	

Common Specifications

Drive system (Note 4)	Ball screw, rolled C10 [equivalent to rolled C5]
Backlash (Note 5)	0.05mm or less [0.02mm or less]
Guide	Integrated with base
Base	Material: Aluminum with white alumite treatment
Cable length (Note 6)	3L: 3m, 5L: 5m, □L: Length specification
Cable management	CT: Cable track

Load Capacity by Acceleration (kg)

Acceleration (G) \ Y-axis stroke (mm)	500	600	700
0.3	40.0	40.0	40.0
0.4			
0.5			
0.6			
0.7			
0.8			
0.9			
1.0			

Maximum Speed by Stroke (mm/sec)

Axis \ Stroke (mm)	500 ~ 700	1000 ~ 1400	1500	1600	1700	1800	1900	2000	2500
X-axis	—	1000	950	830	740	650	590	540	300
Y-axis	1000	—	—	—	—	—	—	—	—

Applicable Controller Specifications

Applicable controller	Controller type	Model	Page
X-SEL	General-purpose type	XSEL-K-2-400□-200□-□-□□□-□-□	
	Compact type	XSEL-J-2-400□-200□-□-□□□-□-□	

Caution

(Note 1) The maximum speed will vary depending on the stroke. (Refer to the table of maximum speed by stroke.)
 (Note 2) The load capacity assumes operation at the rated acceleration (0.3 G). The rated acceleration is the maximum specifiable acceleration for both the ICSA2 and ICSPA2.
 (Notes 3, 4, 5) The figures in brackets apply to the ICSPA2.
 (Note 6) The cable length measures from the X-axis connector box to the controller.
 The standard lengths are 3 m and 5 m, but other lengths can also be specified in meters up to 20 m (e.g., 10L = 10 m).

* Refer to page 59 for other points to note.

Cable Track Specification (Cable Management Code: CT)

Single-Axis Robots
Cartesian Robots

Dimensions

* Note that changing the home direction will require the actuator to be returned to IAI for adjustment.

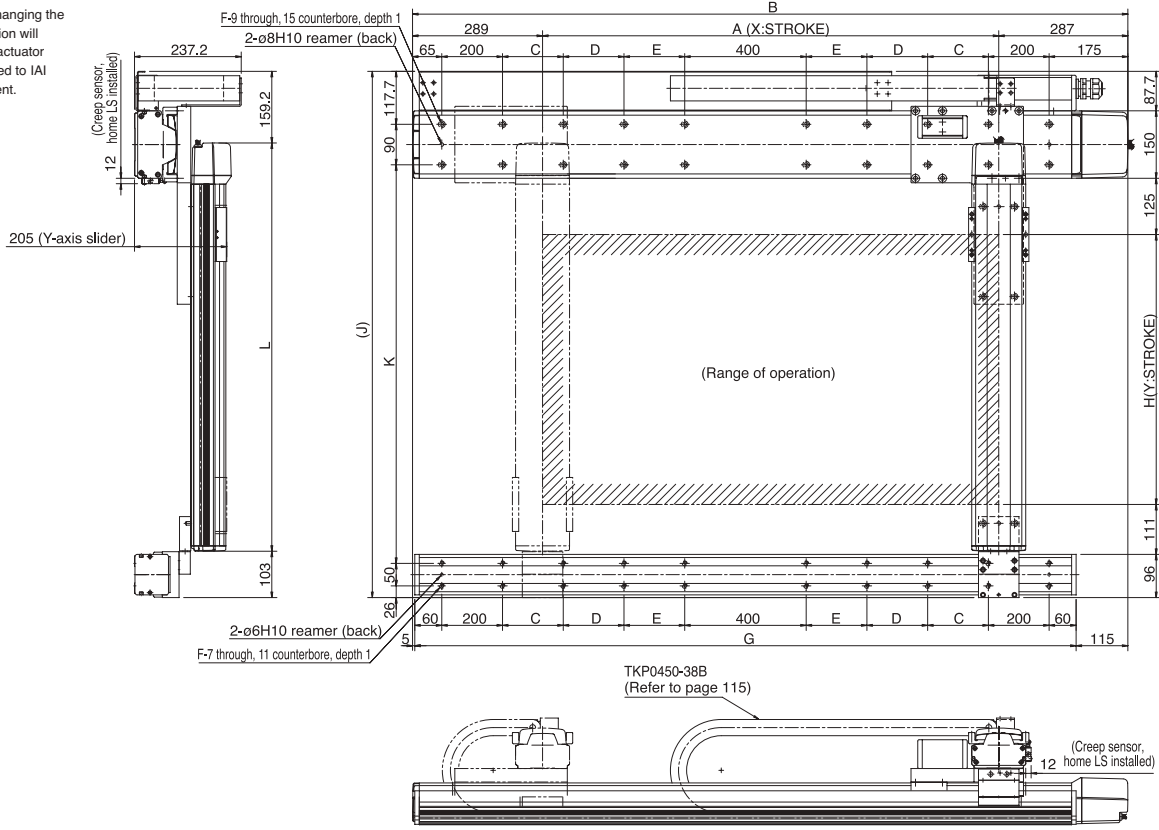

Y-axis dimensions

□	500	600	700
□	1069.7	1169.7	1269.7
□	786	886	986
□	807.5	907.5	1007.5

* Shipment of a combined type requires frame (to be provided separately).

X-axis dimensions

A	1014	1114	1214	1314	1414	1514	1614	1714	1814	1914	2014	2114	2214	2314	2414	2514
B	1590	1690	1790	1890	1990	2090	2190	2290	2390	2490	2590	2690	2790	2890	2990	3090
C	275	325	375	425	475	525	575	200	200	200	200	200	200	200	200	200
D	0	0	0	0	0	0	0	425	475	525	575	200	200	200	200	200
E	0	0	0	0	0	0	0	0	0	0	425	475	525	575	625	625
F	12	12	12	12	12	12	12	16	16	16	16	20	20	20	20	20
G	1470	1570	1670	1770	1870	1970	2070	2170	2270	2370	2470	2570	2670	2770	2870	2970

ICSA2-G2JH Cartesian Robot: X-Y 2-Axes Configuration, XYG (Y-Axis Gantry) Type

ICSPA2-G2JH Cartesian Robot: X-Y 2-Axes Configuration, XYG (Y-Axis Gantry) Type **High-Precision Specification**

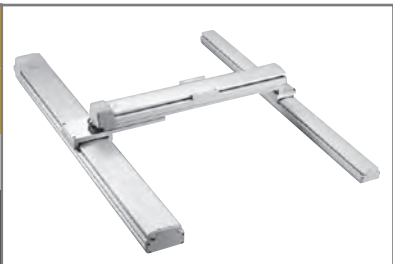

Type **XYG type** Stroke X-axis: 1000~2500mm Y-axis: 800~1200mm Load capacity **40kg**

Model specification items Series **ICSA 2** - Type **G2JH** - Encoder type **A** - X-axis stroke + options **250AQLNM** - Y-axis stroke + options **120AQL** - Applicable controller **T1** - Cable length **5L** - Cable management **CT**

* Refer to page 61 for the details of model specification items.

Models/Specifications

Model	Axis configuration	Encoder type	Motor output (W)	Lead (mm)	Stroke (mm) In increments of 100mm	Speed (mm/s) (Note 1)	Load capacity (Note 2)	Positioning repeatability (mm) (Note 3)
ICSA2 [ICSPA2] -G2JH-A-***-***-T1-Δ-CT	X-axis ISA [ISPA] -LXUWX-A-400-20-***-T1	Absolute	400	20	1000 ~ 2500	1 ~ 1000	40	±0.02 [±0.01]
	Y-axis ISA [ISPA] MXMX-A-200-20-***-T1		200		800 ~ 1200			
ICSA2 [ICSPA2] -G2JH-I-***-***-T1-Δ-CT	X-axis ISA [ISPA] -LXUWX-I-400-20-***-T1	Incremental	400		1000 ~ 2500			
	Y-axis ISA [ISPA] MXMX-I-200-20-***-T1		200		800 ~ 1200			

* In the above model names, *** indicates the stroke/applicable options (stroke is specified in centimeters), and Δ the cable length.

Options

Name	Code	Page	Remarks
AQ seal	AQ	P13	
Brake	B	P13	
Creep sensor	C	P13	
Home limit switch	L	P14	
Reverse homing specification	NM	P14	
Guide with ball-retaining mechanism	RT	P14	

Common Specifications

Drive system (Note 4)	Ball screw, rolled C10 [equivalent to rolled C5]
Backlash (Note 5)	0.05mm or less [0.02mm or less]
Guide	Integrated with base
Base	Material: Aluminum with white alumite treatment
Cable length (Note 6)	3L: 3m, 5L: 5m, □L : Length specification
Cable management	CT: Cable track

Load Capacity by Acceleration (kg)

Y-axis stroke (mm)	800	900	1000	1100	1200
Acceleration (G)					
0.3	40.0	40.0	40.0	40.0	40.0
0.4					
0.5					
0.6					
0.7					
0.8					
0.9					
1.0					

Maximum Speed by Stroke (mm/sec)

Stroke (mm)	800 ~ 1200	1000 ~ 1400	1500	1600	1700	1800	1900	2000	2500
X-axis	-	1000	950	830	740	650	590	540	300
Y-axis	1000	-	-	-	-	-	-	-	-

Applicable Controller Specifications

Applicable controller	Controller type	Model	Page
X-SEL	General-purpose type	XSEL-K-2-400□-200□-□-□□□-□-□	
	Compact type	XSEL-J-2-400□-200□-□-□□□-□-□	

Caution

(Note 1) The maximum speed will vary depending on the stroke. (Refer to the table of maximum speed by stroke.)

(Note 2) The load capacity assumes operation at the rated acceleration (0.3 G). The rated acceleration is the maximum specifiable acceleration for both the ICSA2 and ICSPA2.

(Notes 3, 4, 5) The figures in brackets apply to the ICSPA2.

(Note 6) The cable length measures from the X-axis connector box to the controller. The standard lengths are 3 m and 5 m, but other lengths can also be specified in meters up to 20 m (e.g., 10L = 10 m).

* Refer to page 59 for other points to note.

Cable Track Specification (Cable Management Code: CT)

Dimensions

* Note that changing the home direction will require the actuator to be returned to IAI for adjustment.

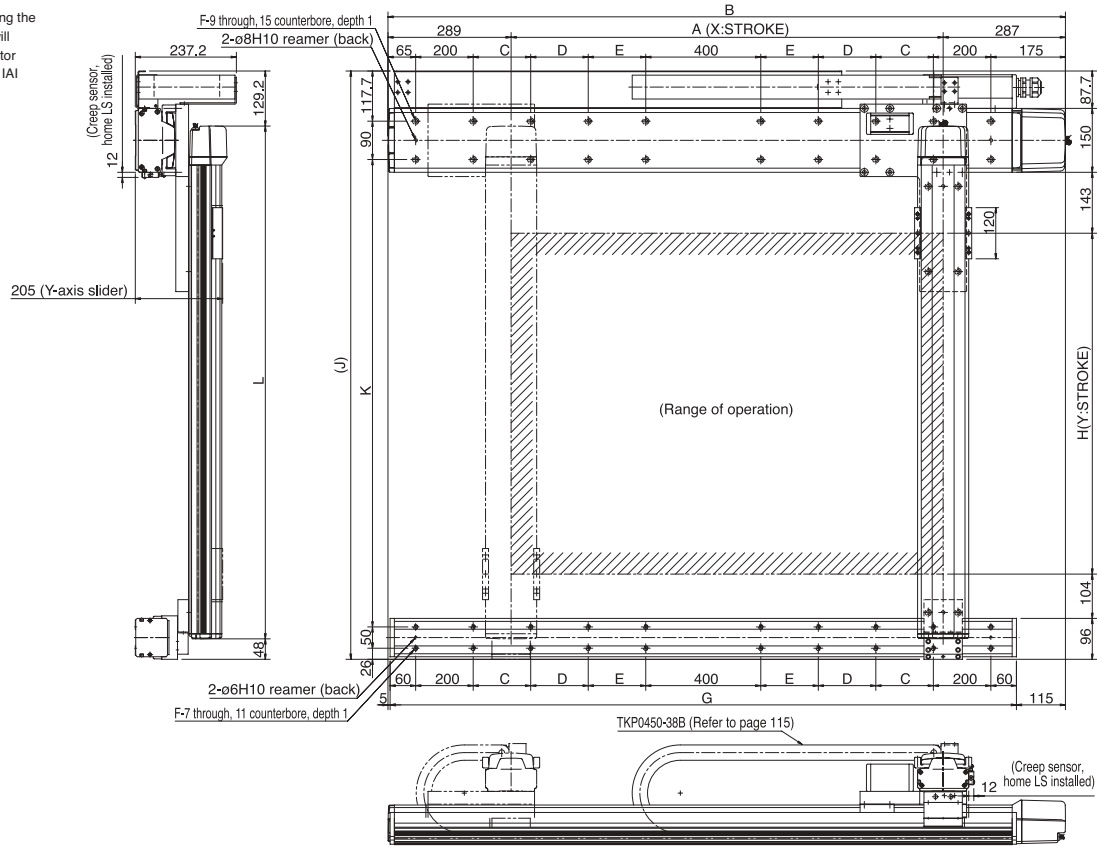

Y-axis dimensions

H	800	900	1000	1100	1200
J	1380.7	1480.7	1580.7	1680.7	1780.7
K	1097	1197	1297	1397	1497
L	1203.5	1303.5	1403.5	1503.5	1603.5

* Shipment of a combined type requires frame (to be provided separately).

X-axis dimensions

A	1014	1114	1214	1314	1414	1514	1614	1714	1814	1914	2014	2114	2214	2314	2414	2514
B	1590	1690	1790	1890	1990	2090	2190	2290	2390	2490	2590	2690	2790	2890	2990	3090
C	275	325	375	425	475	525	575	200	200	200	200	200	200	200	200	200
D	0	0	0	0	0	0	0	425	475	525	575	200	200	200	200	200
E	0	0	0	0	0	0	0	0	0	0	425	475	525	575	625	625
F	12	12	12	12	12	12	12	16	16	16	16	20	20	20	20	20
G	1470	1570	1670	1770	1870	1970	2070	2170	2270	2370	2470	2570	2670	2770	2870	2970