

ELECYLINDER® EC



Simple & Wireless Operation



New Product

IP67 Splash-proof Specification
Radial Cylinder®



Simple ELECYLINDER®

Working just **5** minutes
after setting speed
and acceleration!!



EC
ELECYLINDER®

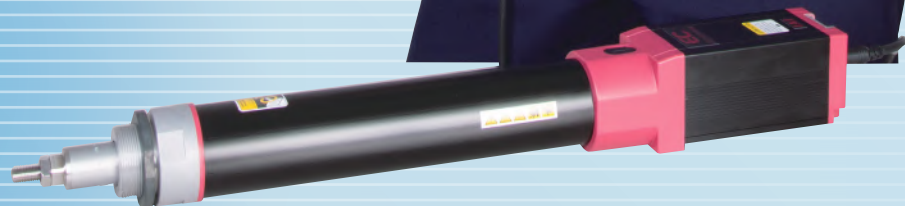



EC
ELECYLINDER®

Simple

ELECYLINDER®

- Simple model selection.
- Easy to operate, even with no electrical expertise.
- Easily repaired by operators in the event of a breakdown.
- Few maintenance parts.



P.3

High Performance

ELECYLINDER®

- Acceleration (A), Velocity (V), and Deceleration (D) can be adjusted individually.
- Start and end points can be set at any value.
- Faster cycle time.
- The slider type Radial Cylinder is equipped with a built-in guide.



P.7

Profitable

ELECYLINDER®

- Faster cycle time means increased productivity and reduced labor costs.
- Greatly reduces momentary stops on the production line.
- Long product life. Usable for up to 20 years with low loads.



P.11

Simple

ELECYLINDER®

ELECYLINDER® operation is **extremely simple**.

Easily repairable in the event of a breakdown.

Simple model selection

■ Select the ideal model easily with model selection software.

➔ <https://www.intelligentactuator.com/ec1>

Simple programming-free operation

Operation is possible with data entry. No need to perform complicated programming.

Operation is possible with ON/OFF signal, just like solenoid valves.

Start and end points can be set to any position

■ Enter stop position.

The diagram illustrates the process of setting stop positions. On the left, a keypad shows the 'ENT' key being pressed. On the right, a cylinder diagram shows the 'Backward end (home end)' at 0.00 mm and the 'Forward end' at 100.00 mm.

AVD values are easily set

■ Enter the operating conditions.

Operating conditions abbreviation: AVD

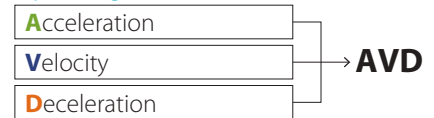

The diagram shows the keypad with 'ENT' pressed and a speed-time graph. The graph plots Speed vs. Time, showing a cycle time of 1.27s. The graph is divided into three regions: Acceleration (A), Velocity (V), and Deceleration (D). The 'Push' button is indicated as active.

Operating conditions

(Push forward: Backward end → Forward end)

A: Acceleration (%) 70

V: Velocity (%) 100

D: Deceleration (%) 50

Speed

Cycle time 1.27s

V: Velocity

A: Acceleration D: Deceleration

Time

Push



EC
ELECYLINDER®

Easily repairable in the event of a breakdown.

Troubleshooting can be performed using the teaching pendant.

Device stoppage causes and countermeasures are displayed.

In nearly all cases, just replace the motor or controller circuit board yourself and the unit will recover.

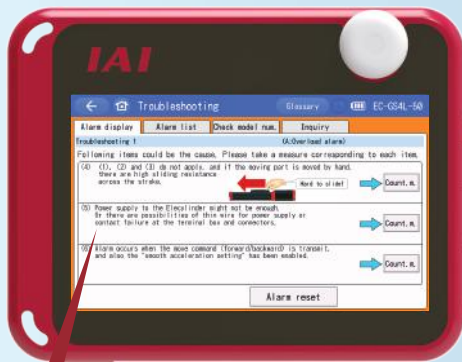

Point 1 The optimal countermeasure is displayed.

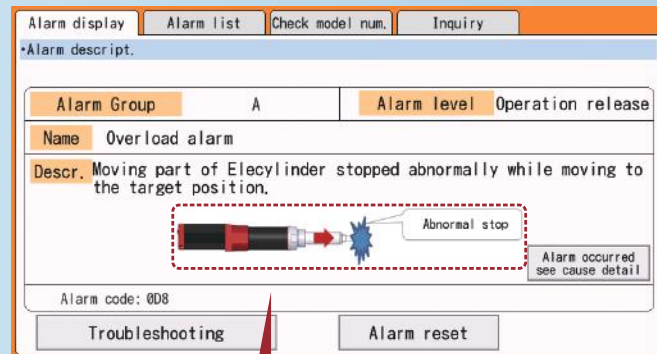

Point 2 Causes and countermeasures are displayed with illustrations.

Few maintenance parts

Since the ball screw and guide hardly ever break down, the only maintenance parts are

- (1) Motor cover assembly (including controller circuit board)
- (2) Motor unit

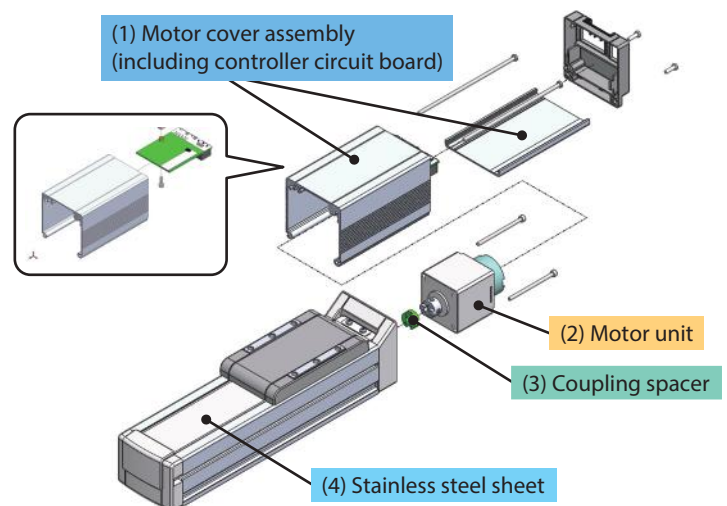

* Rear cover is not included in the motor cover assembly.

* Bolts are not included in the motor cover assembly and motor unit.

Simple

ELECYLINDER®

ELECYLINDER® is connected **wirelessly** and easy to use by anyone.

No troublesome cable connection is necessary.

The ELECYLINDER® main unit (controller) and the touch panel teaching pendant TB-03 can be connected wirelessly, eliminating troublesome cable connections.

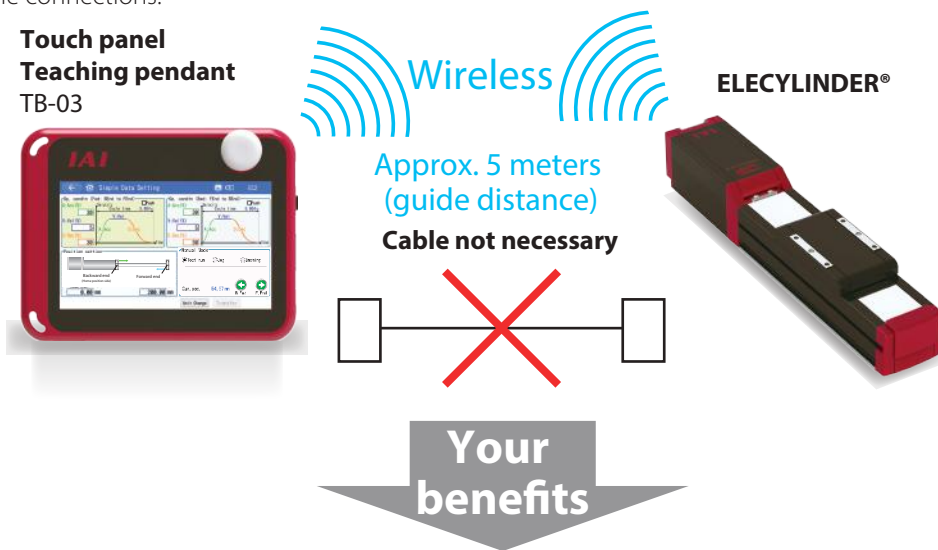

Easy adjustments are possible by watching the parts closer.

Wireless operations from the TB-03 enable the operator to watch the part to be adjusted closer to it, allowing easier position adjustments, operating condition inputs and trial operations. It make customer's adjustment works more efficient.

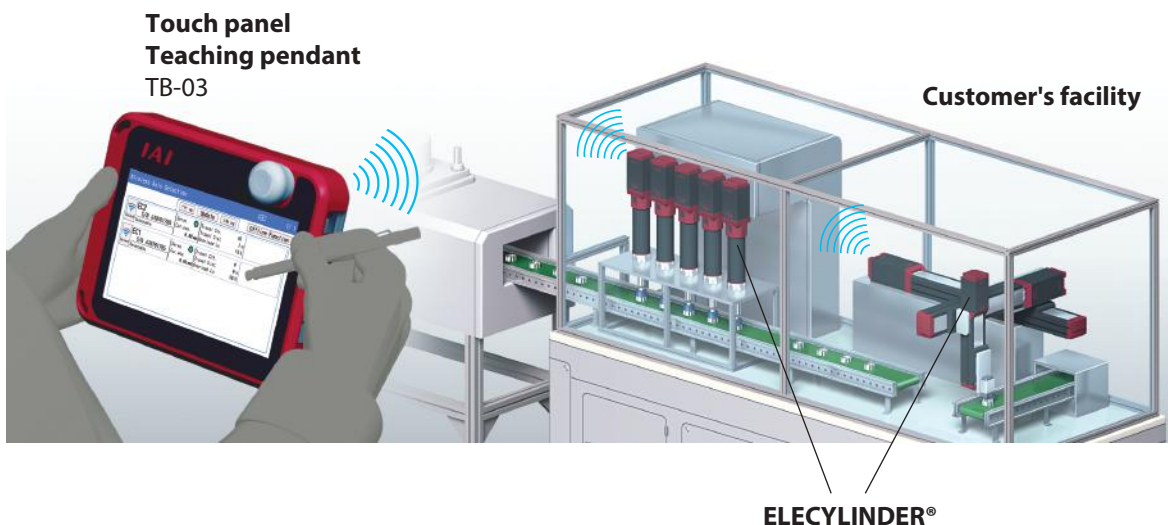



EC
ELECYLINDER®

Reduced trouble recovery time and easier daily inspection

The TB-03 receives data wirelessly from the ELECYLINDER® continuously and displays operating conditions up to 16 axes on its screen for monitoring at a glance.

The ELECYLINDER® showing "Maintenance needed / Alarm ringing" can be identified easily from the list on the screen.

Touch panel Teaching pendant TB-03

Monitor screen for operating conditions

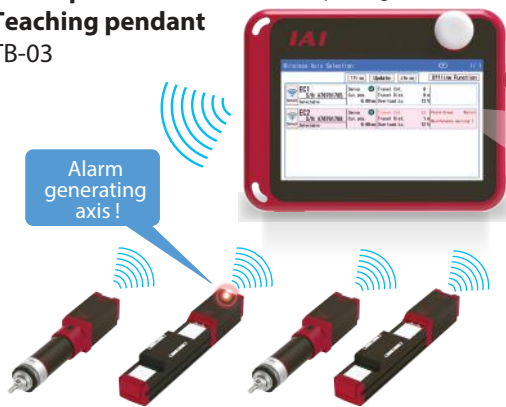

Display of axis names

The names can be selected (changed) freely.

Condition monitoring

The axis conditions can be monitored, enabling a maintenance timing to be confirmed.

EC2 S/N A70761788 Selectable	Servo	Travel Cnt.	52	Alarm Group	Warnin
	Cur. pos. 0.00 mm	Travel Dist. Over load Lv.	1 m 12 %	Maintenance warning 1	

Error status monitor

Displays when an alarm or warning has generated. Useful for troubleshooting.

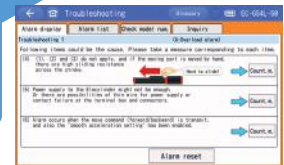

Troubleshooting screen

ELECYLINDER® (connectable up to 16 axes)

Easy to operate by anyone

The ELECYLINDER® can be operated by simply pushing the forward and backward buttons. No expertise is needed.

Touch panel Teaching pendant TB-03

Simple screen for operation

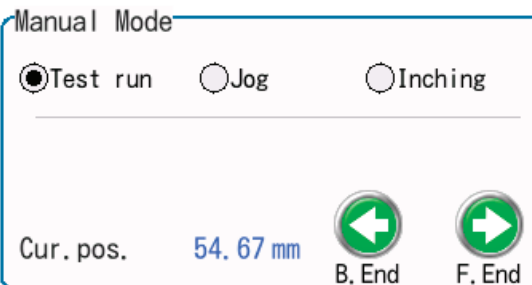
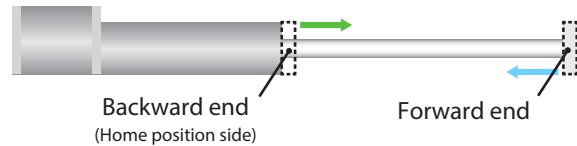

(Note) For wireless operations of the ELECYLINDER®, there are safety cautions. Please make sure to refer to P126.

High Performance

ELECYLINDER®

Easy operation and **High Performance** too.

AVD can be adjusted individually

Air cylinders use flow valves to control its speed by adjusting the air flow rate of a speed controller. It is impossible to control speed, acceleration and deceleration accurately.

The **ELECYLINDER®** can control them accurately by entering AVD individually in percentages. You can enter these values in percentages or actual numeric values {within system limitations}

Operating conditions abbreviation: AVD

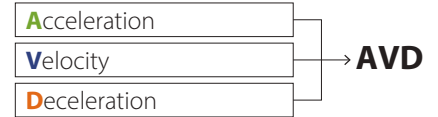

Air cylinder operation

Flow valves
Adjust velocity with air-flow throttle

Air cylinder
Pulling operation

Operating conditions

A: Acceleration (%)

V: Velocity (%)

D: Deceleration (%)

Speed

Cycle time 1.27s

V: Velocity

A: Acceleration D: Deceleration

Time

Shorter Cycle Times

Air cylinders cannot operate at high velocity due to the impact at stroke ends which occurs when excess velocity is applied. The **ELECYLINDER®** can start and stop smoothly at high velocity, reducing cycle time.

Speed (mm/s)

700

300

Time (s)

0.4sec

0.66sec

ELECYLINDER®

- Max. speed: **700 mm/s**
- Acceleration: **1G**
- Stroke: **200mm**

↓

Cycle time

0.4seconds

Air cylinder

- Average speed: **300 mm/s**
- Stroke: **200mm**

↓

Cycle time

0.66seconds

* Research conducted at IAI Japan.



EC
ELECYLINDER®

Stable velocity

Has excellent velocity stability even in the low velocity range.
Maintains consistent quality without film slack, even in low-velocity film or sheet pulling operations.

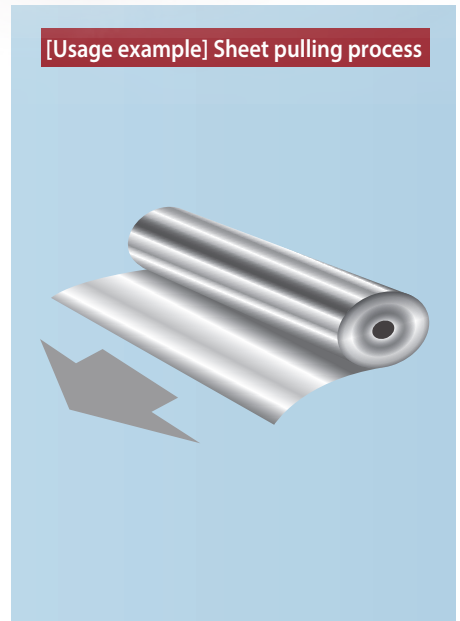
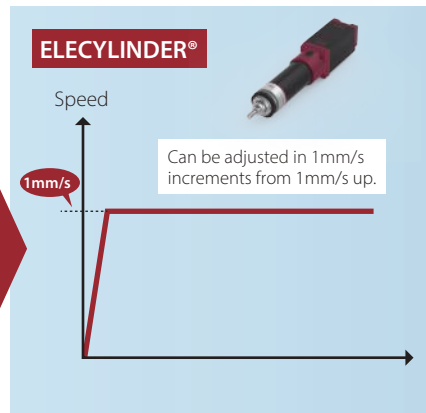
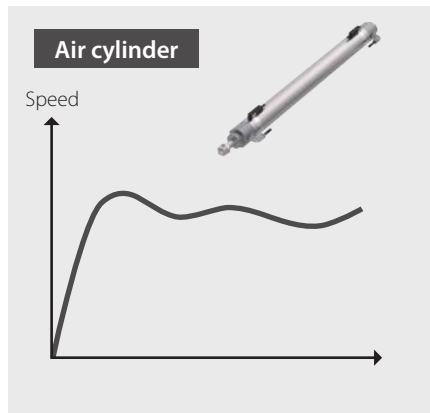

Fine tuning

To set **ELECYLINDER®**'s start/end points, only two desired values are entered.
Air cylinders require position adjustments for mechanical end, auto switch and shock absorber, as well as checking and tuning of each component's positioning.

Position setting

Backward end (home end) mm

Forward end mm

Can be set simply by entering values in the forward end/backward end fields.

High Performance

ELECYLINDER®

Battery-less Absolute Encoder and predictive maintenance function eliminate **time-consuming maintenance work.**

Overload warning and maintenance period notifications

The predictive maintenance function issues an overload warning when the applied load exceeds that of normal operation. It also issues maintenance period reminders.

Preventive maintenance	Predictive maintenance
Operation distance (km/m)	Overload warning
Movement count (times)	

If the criteria are set in advance, the LED built into the body will flash green/red to notify that the maintenance period is up

Battery-less Absolute Encoder can be selected

No Battery means Maintenance free.

Since home return operations are not required at startup or after stops due to emergency and malfunction, work time and production costs can be reduced.

Battery-less Absolute Encoder
No Battery,
No Maintenance, No Homing,
No Going Back to Incremental.

Battery-less means **maintenance-free**

No battery purchase costs and reduced maintenance stock

No battery replacement operation

No battery installation space

No battery-caused mechanical failure



Built-in position memory system



With built-in guide

The slider and radial cylinder types have built-in guides, so no external guide installation is needed. This keeps the equipment profile compact.

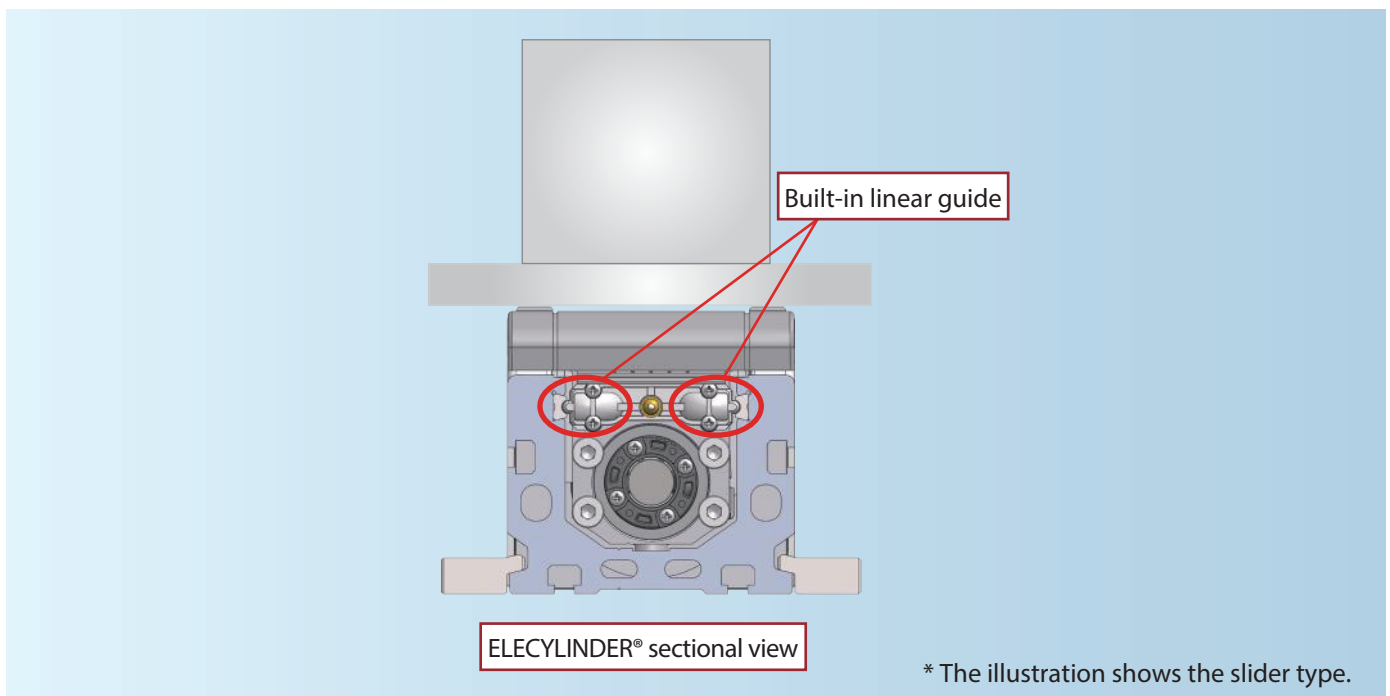

With built-in controller

Built-in controller means no need to allocate controller space inside the control panel. This keeps the control panel size compact.

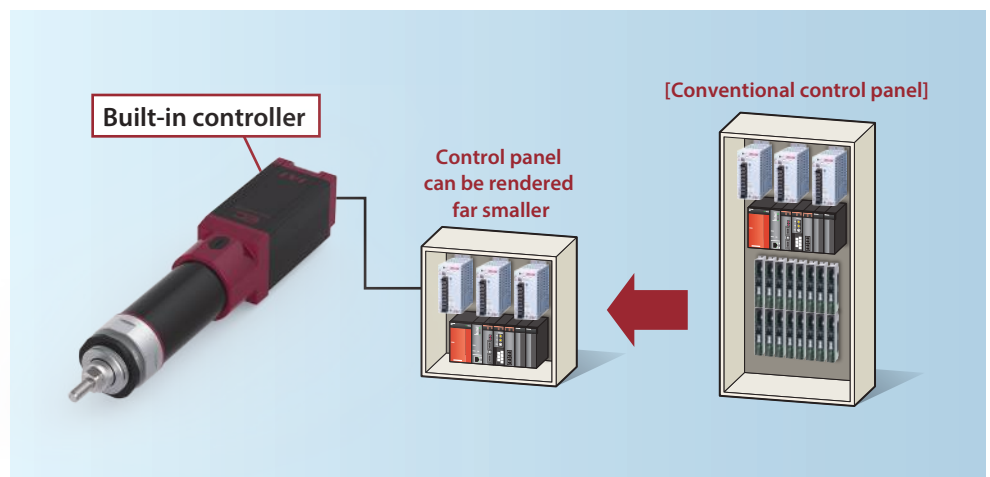

Profitable

ELECYLINDER®

In fact, more ELECYLINDER® operation means **more profit!**

Improves productivity and reduces labor costs

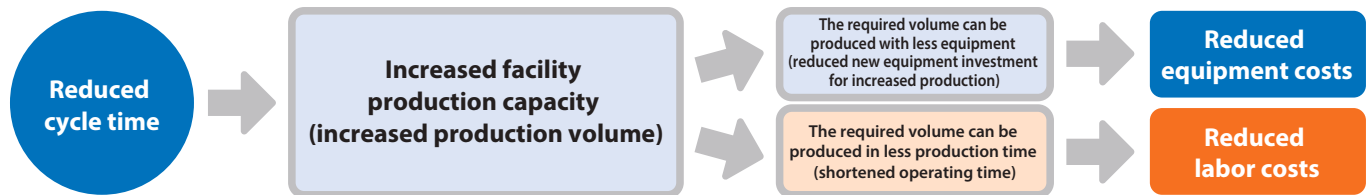

Air cylinders cannot operate at high velocity due to the impact at stroke ends which occurs when excess velocity is applied.

The ELECYLINDER® allows individual adjustment of AVD with percentage input for smooth starting/stopping at high velocity. This enables reduced cycle time.

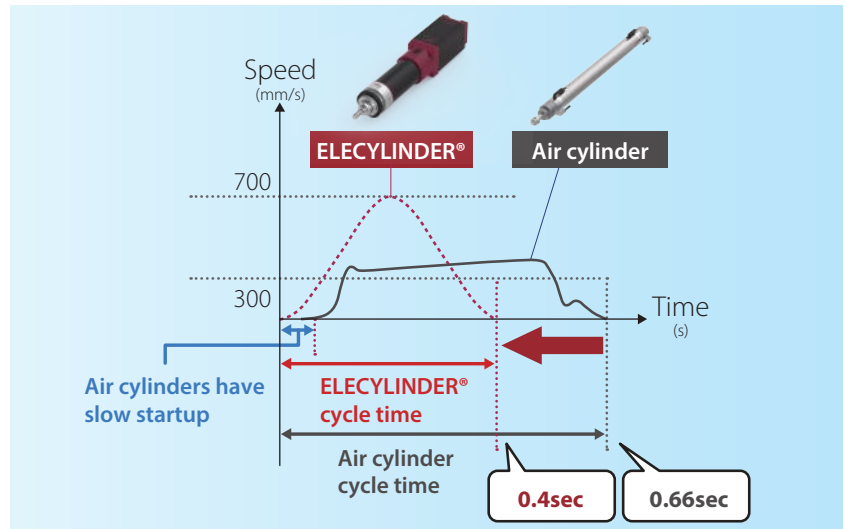

Operating conditions abbreviation: AVD

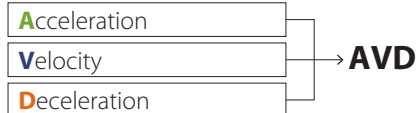

Reduces momentary stops on the production line and improves equipment operating rates

Depending on the state of equipment, various air cylinder issues can trigger momentary stops on the production line.

The ELECYLINDER® can eliminate air cylinder-related momentary stops.

Cause analysis of momentary stops caused by air cylinders

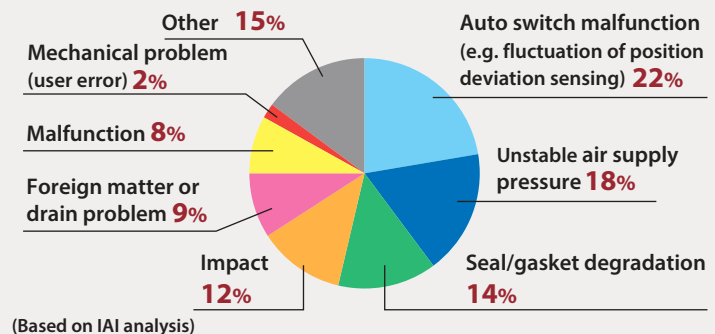





Long service life

Instead of an impact mechanism, the **ELECYLINDER®** incorporates a ball screw and ball circulating type built-in linear guide to achieve a long service life. Based on calculation using the conditions below, the lifespan of the **ELECYLINDER®** is five times longer than that of air cylinders.

Operational conditions

Operating days per year	Operating hours	Movement stroke	Payload	Operation cycle
240 days	16 hours per day	300mm	Horizontal: 12kg	8 seconds per reciprocating motion

Lifespan

Product specifications	Life	Service life	Lifespan factors	Remarks
Air cylinder (rod type) ø32 	3 years	5 million times * Lifespan estimated by cylinder manufacturer	Gasket/ seal degradation	—
ELECYLINDER® (rod type) EC-R7 	15 years	Approx. 16,000km	End of bearing life	Max. speed: 155 mm/s Acceleration/deceleration: 0.5G

The **ELECYLINDER®** lifespan is **5 times** longer than that of air cylinders

Reduces electricity bills

The difference in the rate of power consumption for the **ELECYLINDER®** and air cylinders depends on the operational frequency. The higher the operational frequency, the more effective the energy-saving becomes.

Based on tests conducted by IAI, the power consumption of the **ELECYLINDER®** under the following conditions is 1/6 that of air cylinders.

<Operational conditions>	
● ELECYLINDER® : EC-R7	● Acceleration: 0.3G
● Air cylinder: ø32	● Load: 30kg
● Stroke: 300mm	● Installation orientation: Horizontal
● Speed: 280 mm/s	● Operational hours: 16 hours per day
● Operation cycle: 30 seconds per reciprocating motion	
● Operating days per year: 240 days	

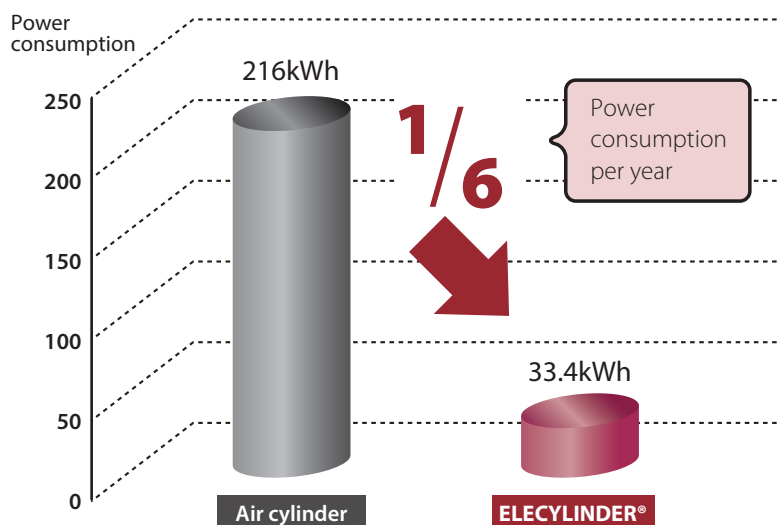

* Research conducted at IAI Japan.

EC Product List

Standard

Small type

EC-S3 ▶ P39

EC-S4 ▶ P41

Attention! Check P.16!

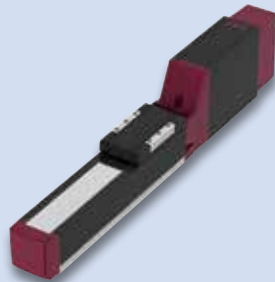

Motor side-mounted

EC-S6□R ▶ P51

EC-S7□R ▶ P53

Attention! Check P.17!

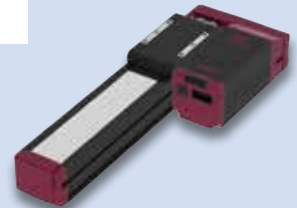

Slider type

EC-S6 ▶ P43

EC-S7 ▶ P45



Rod type

EC-R6 ▶ P59

EC-R7 ▶ P61



<Features>

- For the slider type, the slider on the top of the body operates in the same way as a slider type air cylinder.
- For the rod type, the rod operates in the same way as a rod type air cylinder.

<Applications>

Slider type Suitable for transporting workpieces.

Rod type Suitable for pushing and lifting.

<Application Examples>

Slider type

Transferring between conveyors

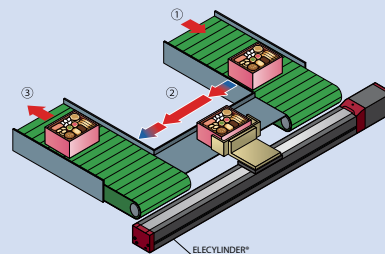

Rod type

Pushes up the set workpiece

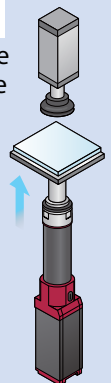

Compact

<Features>

- For the slider type, the table on the top of the body operates.
- For the mini guided rod type, the rod operates.
- The use of a nut rotation mechanism reduces the size.

<Applications>

Suitable for conveying and pushing workpieces in narrow spaces.

Mini Table type

EC-TC4 ▶ P89

EC-TW4 ▶ P91



Attention! Check P.20!

Mini Guided rod type

EC-GS4 ▶ P85

EC-GD4 ▶ P87



Attention! Check P.20!

High Rigidity

NEW Small type Radial Cylinder

EC-RR3 ▶ P63
EC-RR4 ▶ P65



Attention! Check P.16!

NEW Motor side-mounted

EC-S6□AHR ▶ P55
EC-S7□AHR ▶ P57
EC-RR6□R ▶ P75
EC-RR7□R ▶ P77
EC-RR6□AHR ▶ P79
EC-RR7□AHR ▶ P81



Attention! Check P.17!

High rigidity slider type

EC-S6□H ▶ P47
EC-S7□H ▶ P49



High rigidity Radial Cylinder

EC-RR6□AH ▶ P71
EC-RR7□AH ▶ P73



High rigidity Radial Cylinder

EC-RR6 ▶ P67
EC-RR7 ▶ P69



<Features>

- A ball circulating type linear guide is built in.
- The high rigidity slider and high rigidity Radial Cylinder types have a built-in 4-row linear guide. The highly rigid structure supports loads distributed over 4 rows of steel balls.

<Applications>

Radial Cylinder Suitable for swinging operations such as clamping and opening/closing doors.

High rigidity slider type Suitable for applications where a large reaction force is applied, such as tightening screws and drilling holes.

<Application Example>

Door open/close

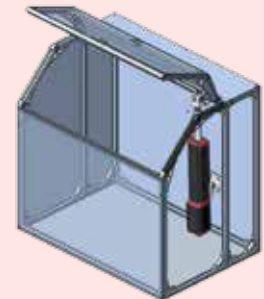

Environmental Resistance

NEW Splash-proof type (Radial Cylinder)

EC-RR6□W ▶ P97
EC-RR7□W ▶ P99

Attention! Check P.15!

Splash-proof type (Rod Type)

EC-R6□W ▶ P93
EC-R7□W ▶ P95

<Features>

- The rod operates in the same way as a rod type air cylinder.
- Waterproof type with ingress protection rating of IP67.
- The Radial Cylinder type is equipped with a ball circulating type built-in linear guide.

<Applications>

- Suitable for use in environments with flying dust or exposure to water.
- Usable in places where food-related equipment is washed.



Immersed in water? No problem!

Splash-proof type Radial Cylinder



EC-RR6□W ▶ P97
EC-RR7□W ▶ P99

1. The ingress protection rating is IP67.

The Splash-proof structure prevents the ingress of water even when immersed, making it suitable for equipment such as food-related machines and washing machines which are exposed to violent splashes of water.

It can also be used in an environment where oil mist is present around processing machines.

Ingress protection Indication

IP □ □

The first number

Protection against ingress from solid objects, including fingers.

The second number

Protection against water.

*Please consult with us when liquid other than water is used.

Description of protection rating

IP67	Solid objects	: Completely protected from ingress by dust or solid particles.
	Water	: No ingress by water, even when immersed.

2. Fluororubber seal option is added as an option.

A fluororubber seal, which has excellent resistance against cutting oil and cleaning fluid, is added as an option to be used for O-rings and gaskets.

(Option code: SLF)

The Radial Cylinder can be used near machine tools where oil mist scatters.



<Application Example>
Processing machine door open/close

3. Equipped with a guide.

A ball circulating type built-in linear guide is equipped in the rod.

The guide part is protected by the water-proof construction, elimination troubles of the guide caused by the environment.

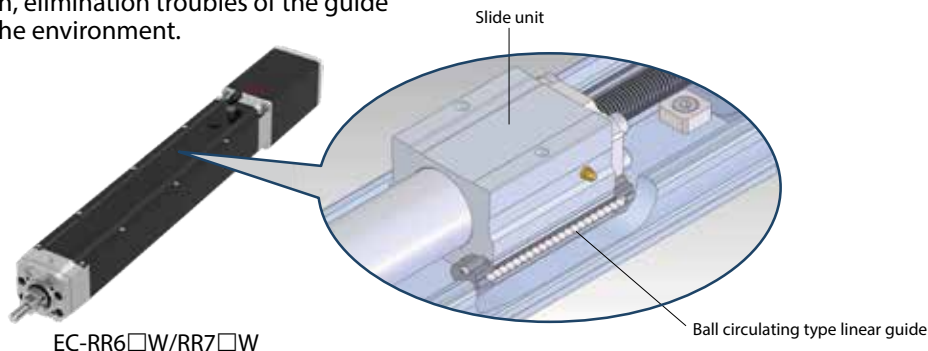

EC-RR6□W/RR7□W

Body widths 35mm and 44mm are now available!

Compact slider Compact Radial Cylinder



1. Compact and lightweight

The body width is only 35mm wide thanks to the built-in controller.

The main unit weight is reduced by 58%, compared to our conventional model with the same stroke.

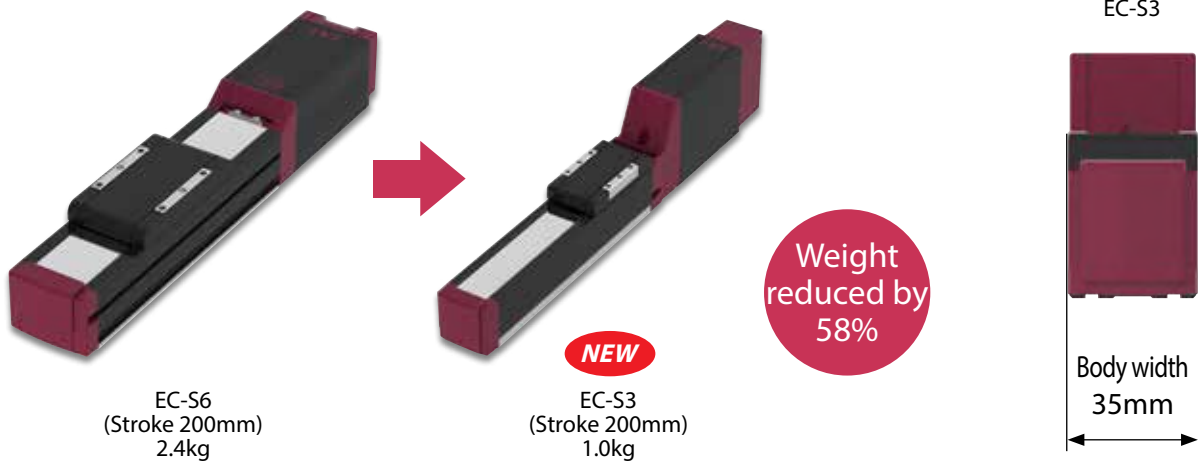

2. Mounting direction of the motor and controller unit is selectable.

The direction of the motor and controller unit can be selected according to the application (See P105).

Retrofit changes of the mounting direction are also possible.

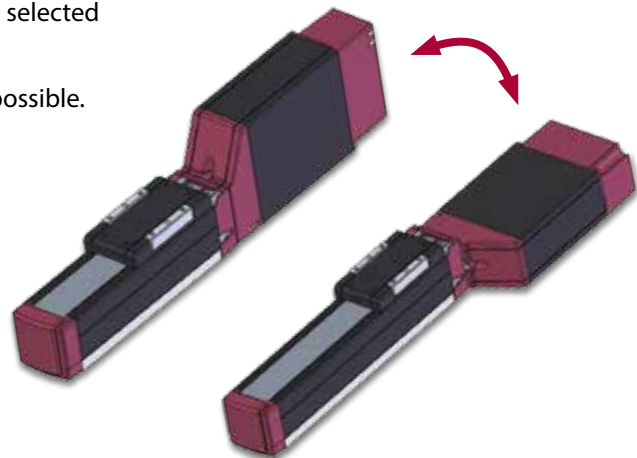

▶ Featured new products

Motor side-mounted type is added as standard!

Motor side-mounted specification

1. The overall length has been shortened.

The overall length has been shortened by up to 133.5mm, allowing a smaller installation space in the longitudinal direction.

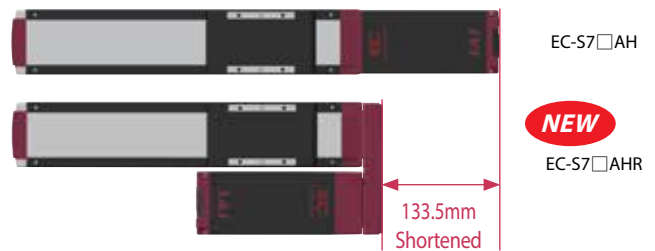

2. No extra space for maintenance is necessary.

A maintenance space required for the straight type is no longer necessary, providing wider options for equipment layout within the facility.

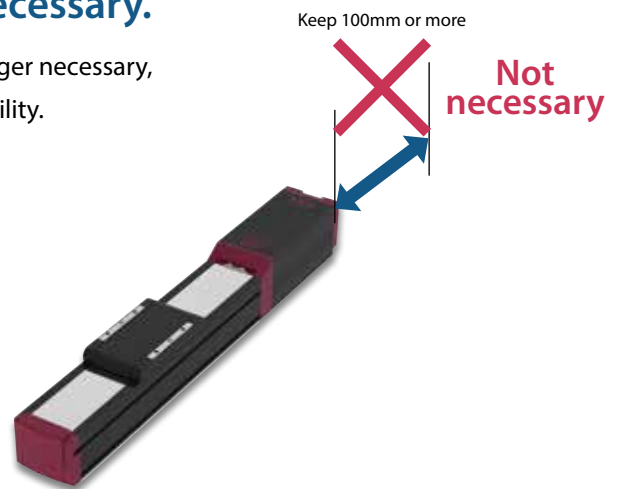

3. Compact combination possible

The shorter overall length results in a shorter overhang length, which allows more compact axes to be used in combined axis systems.

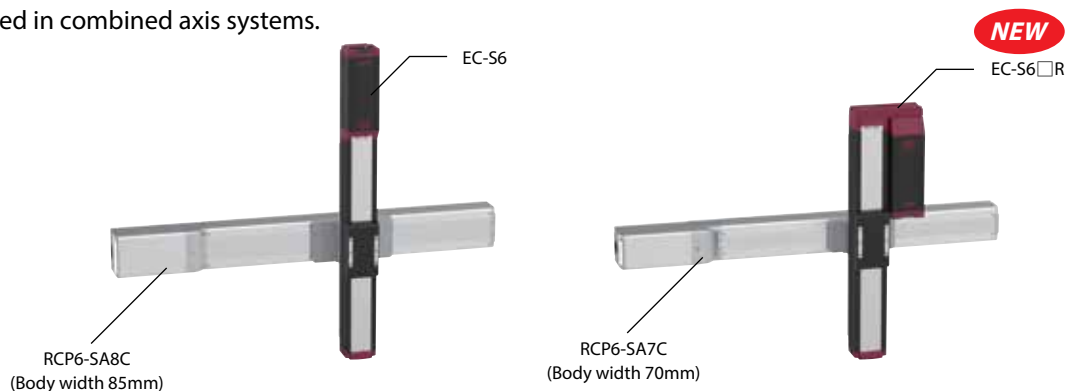

Increased rigidity thanks to the 4-row guide

High Rigidity ELECYLINDER®

4-row linear guide construction (sectional view)

Because of high rigidity

- * Increased dynamic allowable moment
- * Increased load on overhang length
- * Increased transferrable weight

The 4-row steel balls disperse loads

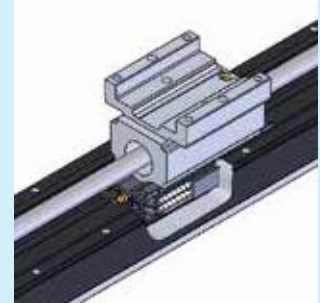
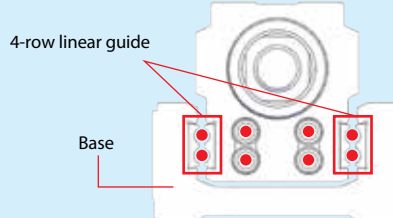

1. Dynamic allowable moment is 3.5 times greater than that of the conventional products.

Slider type

Carry and transfer

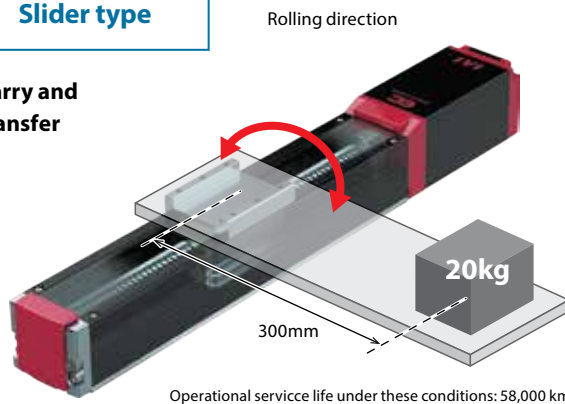

EC-S6□AH ▶ P47
EC-S7□AH ▶ P49

Specifications

	S6□AH	S7□AH
Maximum stroke	800mm	800mm
Maximum payload (horizontal)	40kg	51kg
Dynamic allowable moment (rolling direction)	Mc 55N·m	Mc 134N·m

2. Dynamic allowable radial load at the rod tip is 2.8 times greater than that of the conventional products.

Rod type (Radial Cylinder)

Push
Pull
Press-fit

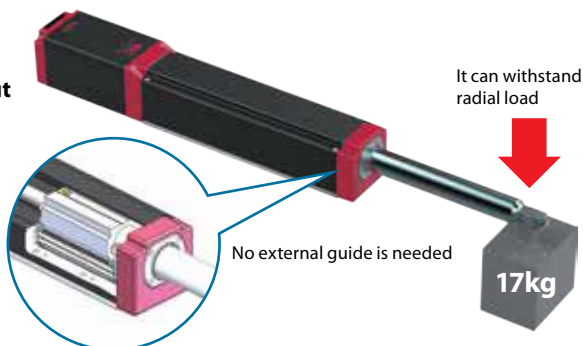

EC-RR6□AH ▶ P71
EC-RR7□AH ▶ P73

Specifications

	RR6□AH	RR7□AH
Longest stroke	400mm	500mm
Dynamic allowable radial load at the rod tip *	130N	170N

* Assuming a basic rated service life of 5,000km.
(Note) Please confirm the conditions specified on P107 before use.

▶ Featured new products

Radial load can be applied without an external guide!

Radial Cylinder®



1. Includes a built-in guide.

The radial cylinder is equipped with a built-in ball circulating type linear guide in the rod body. No external guide is required, as both radial loads and eccentric loads can be applied.

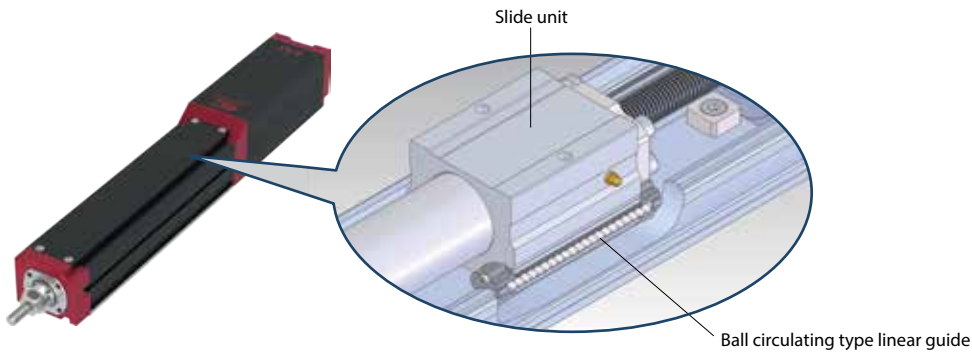

(1) There is no tip runout.

Since it has a built-in linear guide and the rod is supported by the guide, there is no runout to the tip.

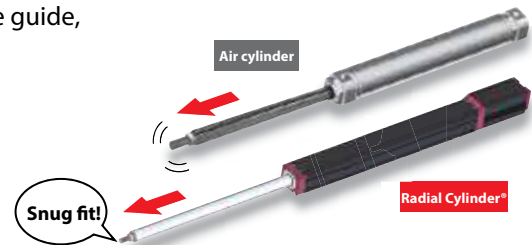

(2) It can be used in narrow spaces.

Since there is no need for an external guide, it can be used even in narrow spaces to save overall space.

The theoretical operation life of the 315mm stroke Radial Cylinder, with a load of 2.9kg applied to the rod tip, is 4,770km. When the load on rod tip is halved, the theoretical service life increases 8-fold.

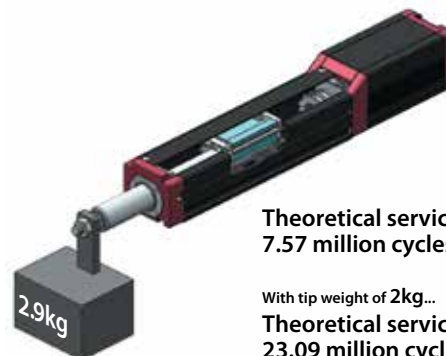
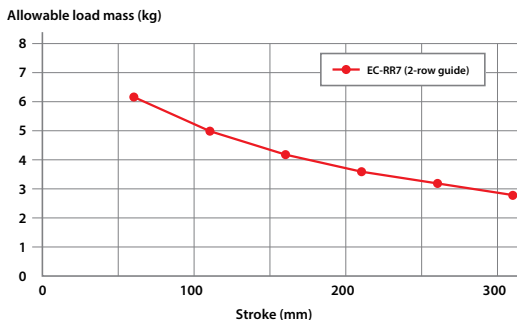

Theoretical service life: 4,770km
7.57 million cycles (when moving 315mm)

With tip weight of 2kg...
Theoretical service life: 14,547km
23.09 million cycles (when moving 315mm)

Palm size

Mini ELECYLINDER®



Mini Table type



Mini Guided rod type

1. It can be used in narrow spaces.

- (1) The use of a nut rotation mechanism reduces the size.
- (2) Even with a built-in controller, the size is a compact 55mm × 105mm × 78mm.

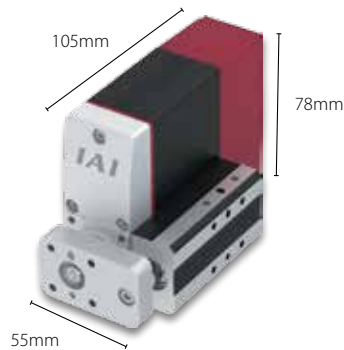

2. As it has a guide, no external guide is required.

- (1) The guide design process can be eliminated.
- (2) It helps save space.

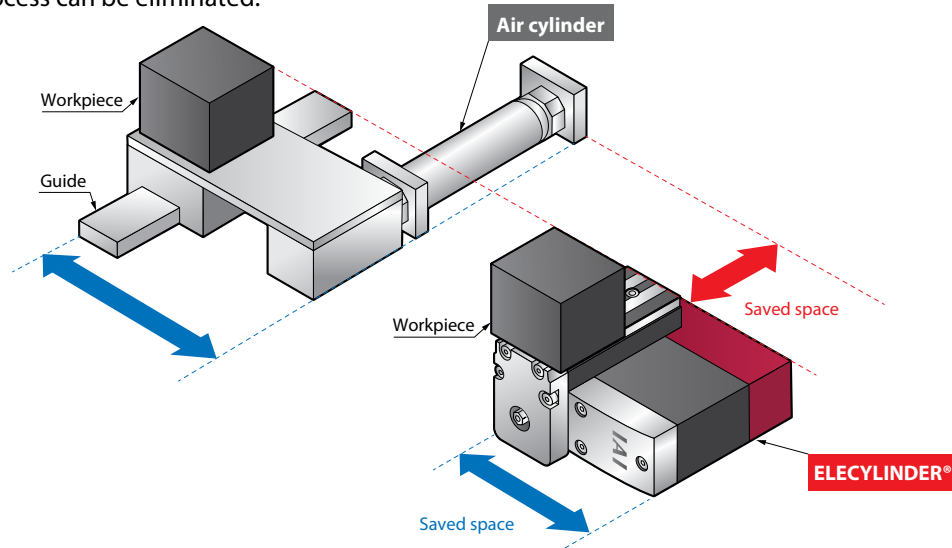

<Applications>

It is suitable to downsize equipment such as production (facility) of small parts.

Device for winding copper wire on a bobbin

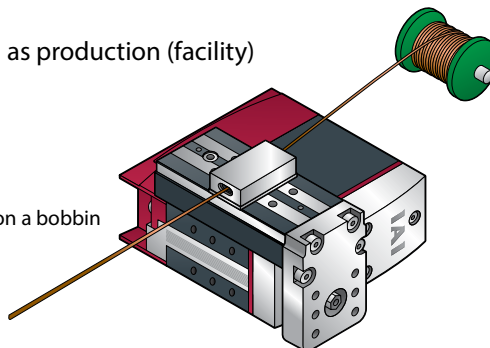

Model Specification Items

ELECYLINDER®

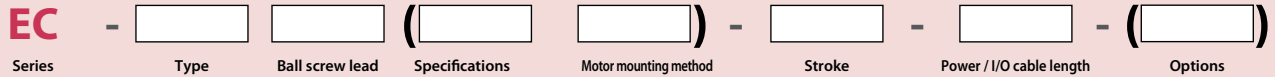

S3	Slider width 35mm
S4	Slider width 44mm
S6	Slider 63mm width
S7	Slider 73mm width (75mm for high rigidity type)
R6	Rod 63mm width
R7	Rod 73mm width
RR3	Radial Cylinder width 35mm
RR4	Radial Cylinder width 44mm
RR6	Radial cylinder 63mm width
RR7	Radial cylinder 73mm width (High rigid type is 75mm)
RP4	Rod type side-mounted motor specification 34mm width
GS4	Rod type side-mounted motor specification 55mm width (with single guide)
GD4	Rod type side-mounted motor specification 76mm width (with double guide)
TC4	Mini table type (table part) 31mm width
TW4	Mini table type (table part) 73mm width

0	0m
?	?
10	10m

Cable length
 0: Power I/O connector supplied
 1 to 10: Power I/O cable supplied

30	30mm
?	?
800	800mm

Left blank	Slider type, rod type, radial cylinder type, mini table type
AH	High rigidity slider type High rigidity radial cylinder type
W	Waterproof specification

Blank	Motor in-line specification
R	Motor side-mounted specification

Left blank	Incremental encoder specification, NPN specification, no option
AC5	Actuator pigtail cable length: 5m
B	Brake
FFA	Tip adapter (flange)
FL	Flange (front)
FT	Foot bracket (bolting from top)
GT2	GS4 guide right mount / TC4 table right mount
GT3	GS4 guide bottom mount / TC4 table bottom mount
GT4	GS4 guide left mount / TC4 table left mount
ML	Motor side-mounted to the left
MR	Motor side-mounted to the right
MOB	Motor mounting direction change (bottom)
MOL	Motor mounting direction change (left)
MOR	Motor mounting direction change (right)
MOT	Motor mounting direction change (top)
NFA	Tip adapter (internal thread)
NJ	Knuckle joint
NJPB	Knuckle joint + oscillation receiving bracket
NM	Non-motor end specification
PN	PNP specification
QR	Clevis bracket
QRPB	Clevis bracket + oscillation receiving bracket
TMD2	Split motor and controller power supply specification
WA	Battery-less Absolute Encoder specification
WL	Wireless communication specification
WL2	Wireless axis-operation specifications

<S3/RR3>

L	Lead 2mm
M	Lead 4mm
H	Lead 6mm

<S4/RR4>

L	Lead 2.5mm
M	Lead 5mm
H	Lead 10mm
S	Lead 16mm

<S6/R6/RR6>

L	Lead 3mm
M	Lead 6mm
H	Lead 12mm
S	Lead 20mm

<S7/R7/RR7>

L	Lead 4mm
M	Lead 8mm
H	Lead 16mm
S	Lead 24mm

<RP4/GS4/GD4/TC4/TW4>



L	Lead 2mm
M	Lead 4mm
H	Lead 6mm

* The range of selectable options varies according to the actuator type. For details, please refer to the pages showing each type.

Product List

Slider Type

* Speed limitation applies to push motion. See the manual or contact IAI.

Spec	Type	External view	Body width (mm)	Lead (mm)	Positioning repeatability (mm)	Stroke (mm)	Max. speed (mm/s)	Max. push force (N)*	Max. payload (kg)		Specifications/drawing
									Horizontal	Vertical	
Coupled Motor	S3		 35mm	6	±0.05	50 to 300 (per 50st)	420	45	3.5	1.5	p39
				4							
				2							
	S4		 44mm	16	±0.05	50 to 300 (per 50st)	800	41	7	1.5	p41
				10							
				5							
				2.5							
	S6		 63mm	20	±0.05	50 to 400 (per 50st)	800	67	15	1	p43
				12							
				6							
				3							
	S7		 73mm	24	±0.05	50 to 500 (per 50st)	860	139	37	3	p45
16											
8											
4											
Motor side-mounted specification	S6□R		 63mm	20	±0.05	50 to 400 (per 50st)	800	67	15	1	p51
				12							
				6							
				3							
	S7□R		 73mm	24	±0.05	50 to 500 (per 50st)	860	139	37	3	p53
				16							
				8							
				4							

Figures in <> represent vertical operations.

High Rigidity Slider Type

* Speed limitation applies to push motion. See the manual or contact IAI.

Spec	Type	External view	Body width (mm)	Lead (mm)	Positioning repeatability (mm)	Stroke (mm)	Max. speed (mm/s)	Max. push force (N)*	Max. payload (kg)		Specifications/drawing
									Horizontal	Vertical	
Coupled Motor	S6□AH		 63mm	20	±0.05	50 to 800 (per 50st)	1440 <1280>	67	15	1	p47
				12							
				6							
				3							
	S7□AH		 75mm	24	±0.05	50 to 800 (per 50st)	1230	139	37	3	p49
				16							
				8							
				4							
Motor side-mounted specification	S6□AHR		 63mm	20	±0.05	50 to 800 (per 50st)	1120	67	15	1	p55
				12							
				6							
				3							
	S7□AHR		 75mm	24	±0.05	50 to 800 (per 50st)	1080 <860>	139	37	3	p57
				16							
				8							
				4							

Figures in <> represent vertical operations.

Product List

Mini Rod Type

* Speed limitation applies to push motion. See the manual or contact IAI.

Spec	Type	External view	Body width (mm)	Lead (mm)	Positioning repeatability (mm)	Stroke (mm)	Max. speed (mm/s)	Max. push force (N)*	Max. payload (kg)		Specifications/drawing
									Horizontal	Vertical	
Motor side-mounted specification	RP4			6	±0.05	30, 50	300	30	2.5	1	P83
				4			200	45	4	1.5	
				2			100	90	8	2.5	
	GS4			6	±0.05	30, 50	300	30	2.5	1	P85
				4			200	45	4	1.5	
				2			100	90	8	2.5	
	GD4			6	±0.05	30, 50	300	30	2.5	1	P87
				4			200	45	4	1.5	
				2			100	90	8	2.5	
Coupled Motor	R6			20	±0.05	50 to 300 (per 50st)	800	67	6	1.5	P59
				12			700	112	25	4	
				6			450	224	40	10	
				3			225	449	60	12.5	
	R7			24	±0.05	50 to 300 (per 50st)	860 (640)	182	20	3	P61
				16			700 (560)	273	50	8	
				8			350	547	60	18	
				4			175	1094	80	19	

Figures in <> represent vertical operations.

Radial Cylinder

* Speed limitation applies to push motion. See the manual or contact IAI.

Spec	Type	External view	Body width (mm)	Lead (mm)	Positioning repeatability (mm)	Stroke (mm)	Max. speed (mm/s)	Max. push force (N)*	Max. payload (kg)		Specifications/drawing
									Horizontal	Vertical	
Coupled Motor	RR3			6	±0.05	50 to 300 (per 50st)	420	45	9	1.5	P63
				4			280	68	14	2.5	
				2			140	136	18	3.5	
	RR4			16	±0.05	50 to 300 (per 50st)	800	41	7	1.5	P65
				10			700	66	16	2.5	
				5			350	132	25	5	
				2.5			175 <150>	263	35	6.5	
	RR6			20	±0.05	65 to 315 (per 50st)	800	67	6	1.5	P67
				12			700	112	25	4	
				6			450	224	40	10	
				3			225	449	60	12.5	
	RR7			24	±0.05	65 to 315 (per 50st)	860 <640>	182	20	3	P69
16				700 <560>			273	50	8		
8				350			547	60	18		
4				175			1094	80	19		
Motor side-mounted specification	RR6□R			20	±0.05	65 to 315 (per 50st)	800	67	6	1.5	P75
				12			700	112	25	4	
				6			450	224	40	10	
				3			225	449	60	12.5	
	RR7□R			24	±0.05	65 to 315 (per 50st)	860 <640>	182	20	3	P77
				16			700 <560>	273	50	8	
				8			320 <280>	547	60	18	
				4			160 <140>	1094	80	19	

Figures in <> represent vertical operations.

High Rigidity Radial Cylinder

* Speed limitation applies to push motion. See the manual or contact IAI.

Spec	Type	External view	Body width (mm)	Lead (mm)	Positioning repeatability (mm)	Stroke (mm)	Max. speed (mm/s)	Max. push force (N)*	Max. payload (kg)		Specifications/drawing
									Horizontal	Vertical	
Coupled motor	RR6□AH			20	±0.05	50 to 400 (per 50st)	800	67	6	1.5	P71
				12			700	112	25	4	
				6			450	224	40	10	
				3			225	449	60	20	
	RR7□AH			24	±0.05	50 to 500 (per 50st)	860 <640>	182	20	3	P73
				16			700 <560>	273	50	8	
				8			350	547	60	18	
				4			175	1094	80	28	
Motor side-mounted specification	RR6□AHR			20	±0.05	50 to 400 (per 50st)	800	67	6	1.5	P79
				12			700	112	25	4	
				6			450	224	40	10	
				3			225	449	60	20	
	RR7□AHR			24	±0.05	50 to 500 (per 50st)	860 <640>	182	20	3	P81
				16			640 <560>	273	50	8	
				8			320 <280>	547	60	18	
				4			150 <140>	1094	80	28	

Table type

* Speed limitation applies to push motion. See the manual or contact IAI.

Spec	Type	External view	Body width (mm)	Lead (mm)	Positioning repeatability (mm)	Stroke (mm)	Max. speed (mm/s)	Max. push force (N)*	Max. payload (kg)		Specifications/drawing
									Horizontal	Vertical	
Motor side-mounted specification	TC4			6	±0.05	30, 50	300	30	2.5	1	P89
				4			200	45	4	1.5	
				2			100	90	8	2.5	
	TW4			6	±0.05	30, 50	300	30	2.5	1	P91
				4			200	45	4	1.5	
				2			100	90	8	2.5	

Splash-proof type

* Speed limitation applies to push motion. See the manual or contact IAI.

Spec	Type	External view	Body width (mm)	Lead (mm)	Positioning repeatability (mm)	Stroke (mm)	Max. speed (mm/s)	Max. push force (N)*	Max. payload (kg)		Specifications/drawing
									Horizontal	Vertical	
Coupled motor	R6□W			20	±0.05	50 to 300 (per 50st)	800	67	6	1.5	P93
				12			700	112	25	4	
				6			450	224	40	10	
				3			225	449	60	12.5	
	R7□W			24	±0.05	50 to 300 (per 50st)	860 <640>	182	20	3	P95
				16			700 <560>	273	50	8	
				8			350	547	60	18	
				4			175	1094	80	19	
Coupled motor	RR6□W			20	±0.05	65 to 315 (per 50st)	800	67	6	1.5	P97
				12			700	112	25	4	
				6			450	224	40	10	
				3			225	449	60	12.5	
	RR7□W			24	±0.05	65 to 315 (per 50st)	860 <640>	182	20	3	P99
				16			700 <560>	273	50	8	
				8			350	547	60	18	
				4			175	1094	80	19	

Figures in < > represent vertical operations

Application Examples

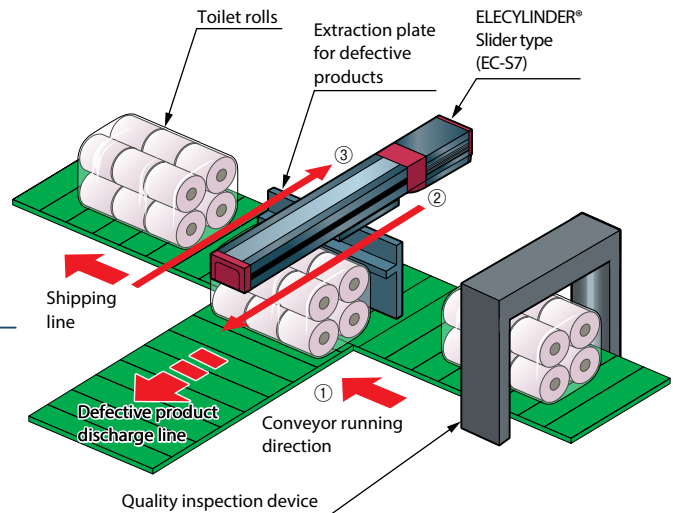

1 Equipment overview

[Application]

The device performs visual inspection of toilet rolls and extracts dirty or cracked products to the discharging conveyor.

The device returns to the standby position after removing defects onto the discharging conveyor.

2 Disadvantages of air cylinders

Disadvantage 1 Velocity could not be set high enough due to the risk of workpieces being flung off the conveyor at high velocity.

Disadvantage 2 Shipping line conveyor was operated at low speed to match the discharging speed.

3 Improvement with ELECYLINDER® implementation

- Smooth acceleration and deceleration even at high velocity means no more workpiece overshoot.

Speed of discharge: Air cylinders 4.2 s \Rightarrow ELECYLINDER® 3.0 s

- Speed of shipping line conveyor was increased.

Shipping line conveyor speed: Air cylinders 4.2m/min \Rightarrow ELECYLINDER® 6m/min

4 Cost reductions achieved with improvement

Production volume per hour **increased by 40%**

(Conventional) 1,500 units \Rightarrow (Improved) 2,100 units = Productivity improved by 600 units/day.

Production volume per day: **15,000**

(Originally) 10 hours \rightarrow (Improvement) 7.1 hours = Reduction of 2.9 hours per day.

Labor costs: \$18 per hour per operator with 230 working days per year

2.9 hours x \$18 x 230 days = \$12,000

Cost reduction of \$12,000 per year has been achieved.

1 Equipment overview

[Application]

A device for opening and closing the hatch located at the process where cardboard boxes are conveyed to the shipping platform.

There are five conveyor lines in this factory, using five hatches in total.

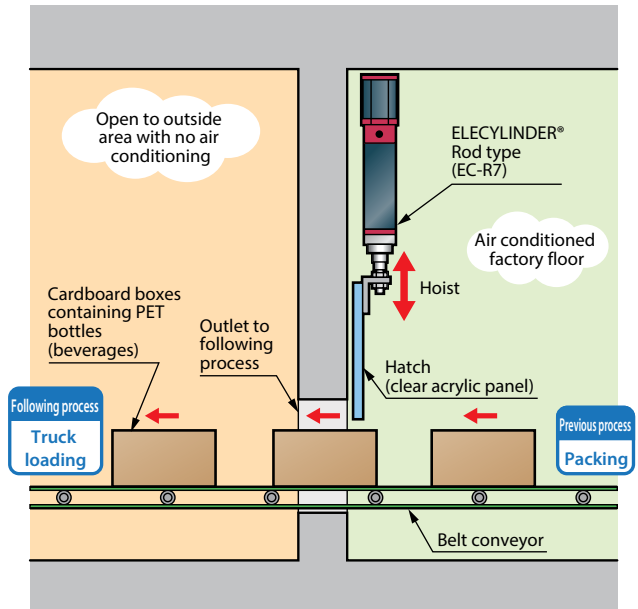

2 Disadvantages of air cylinders

Disadvantage 1 Impact at the upper and lower ends damaged the acrylic panels of the hatches, which required annual replacement.

Disadvantage 2 Due to production line HVAC and cycle time issues, the open/close time could not be reduced.

3 Improvement with ELECYLINDER® implementation

- Adjustment of velocity achieved fast and smooth open/close motion and eliminated impact damage to the hatches.

4 Cost reductions achieved with improvement

Hatch panel replacement was no longer required, reducing costs as follows.

Hatch panel cost: \$300 per piece

Replacement operation cost: \$36 per replacement

Total for five production lines: $(\$300 + \$36) \times 5 = \$1,680$

Cost reduction of \$1,680 per year has been achieved.

Mounting method

Slider type (S3/S4/S6/S7)

■ When using a square nut

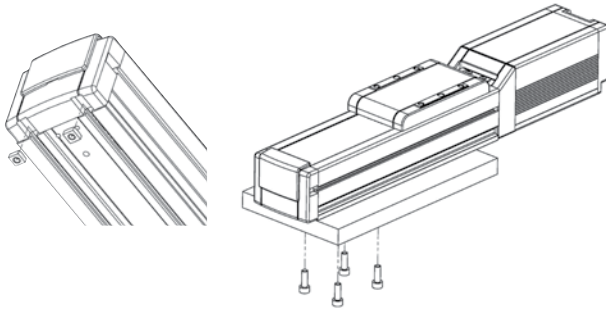

Number of square T nuts included: 6

■ When using a hoot bracket
(Option code: FT)

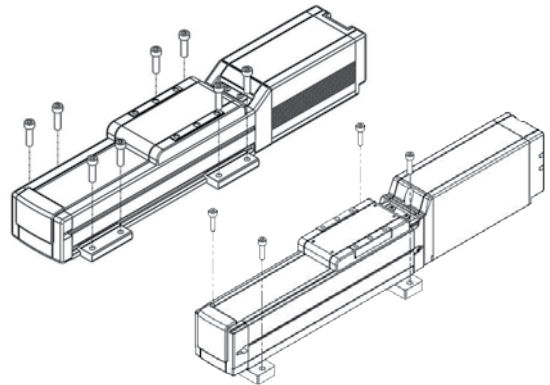

Slider type motor side-mounted specification (S6□R/S7□R)

■ When using a square nut

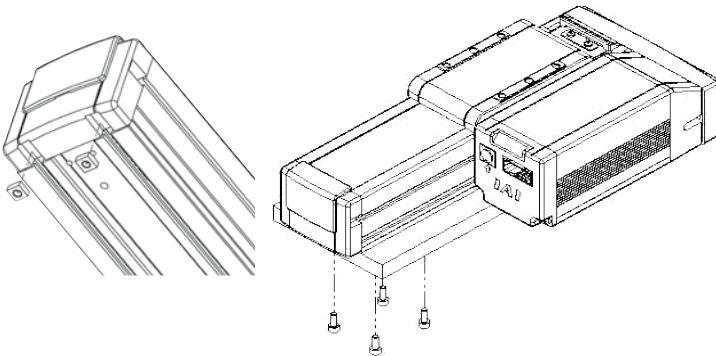

Number of square nuts supplied: 6

■ When using a hoot bracket
(Option code: FT)

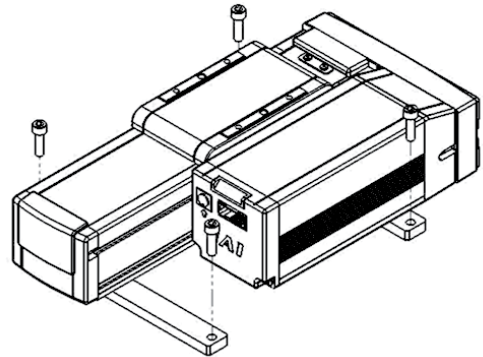

High rigidity slider type (S6□AH/S7□AH)

■ When using through holes at
the top surface

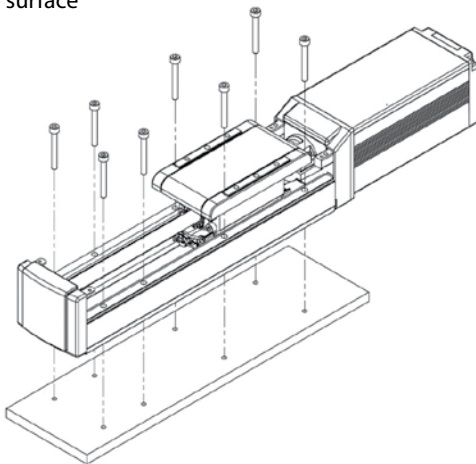

■ When using tap holes at the bottom
surface

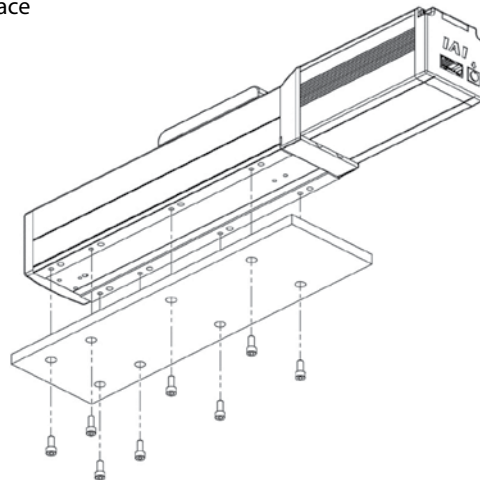

High rigid slider type motor side-mounted specification (S6□AHR/S7□AHR)

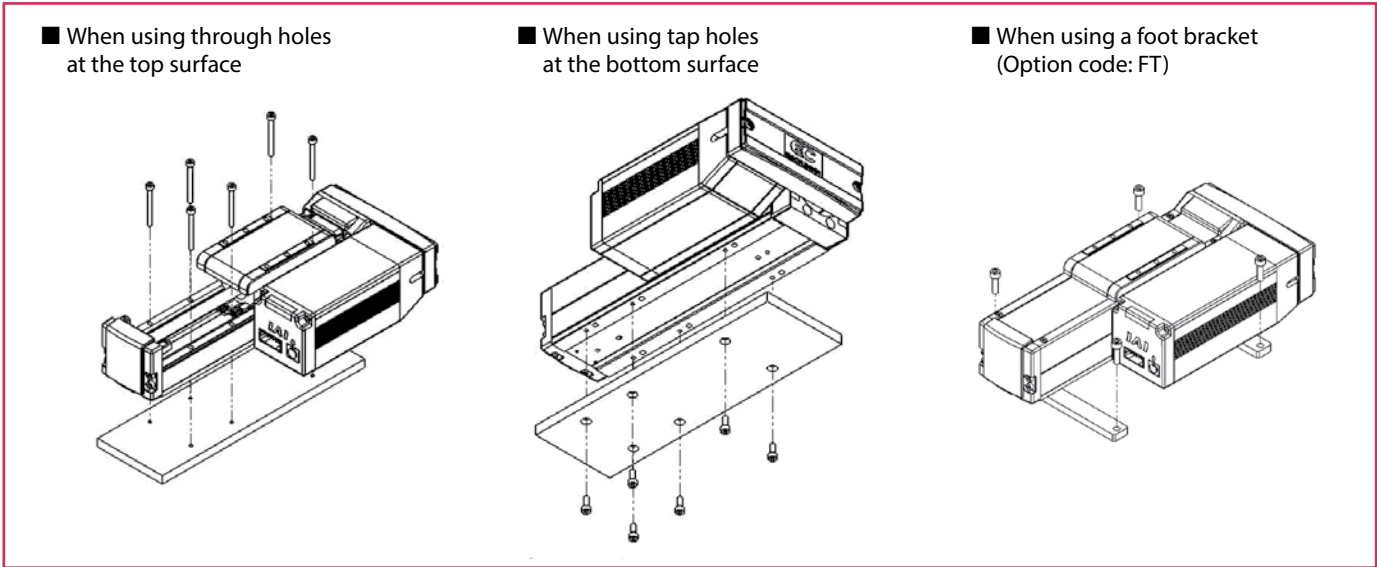

Rod type (R6/R7)

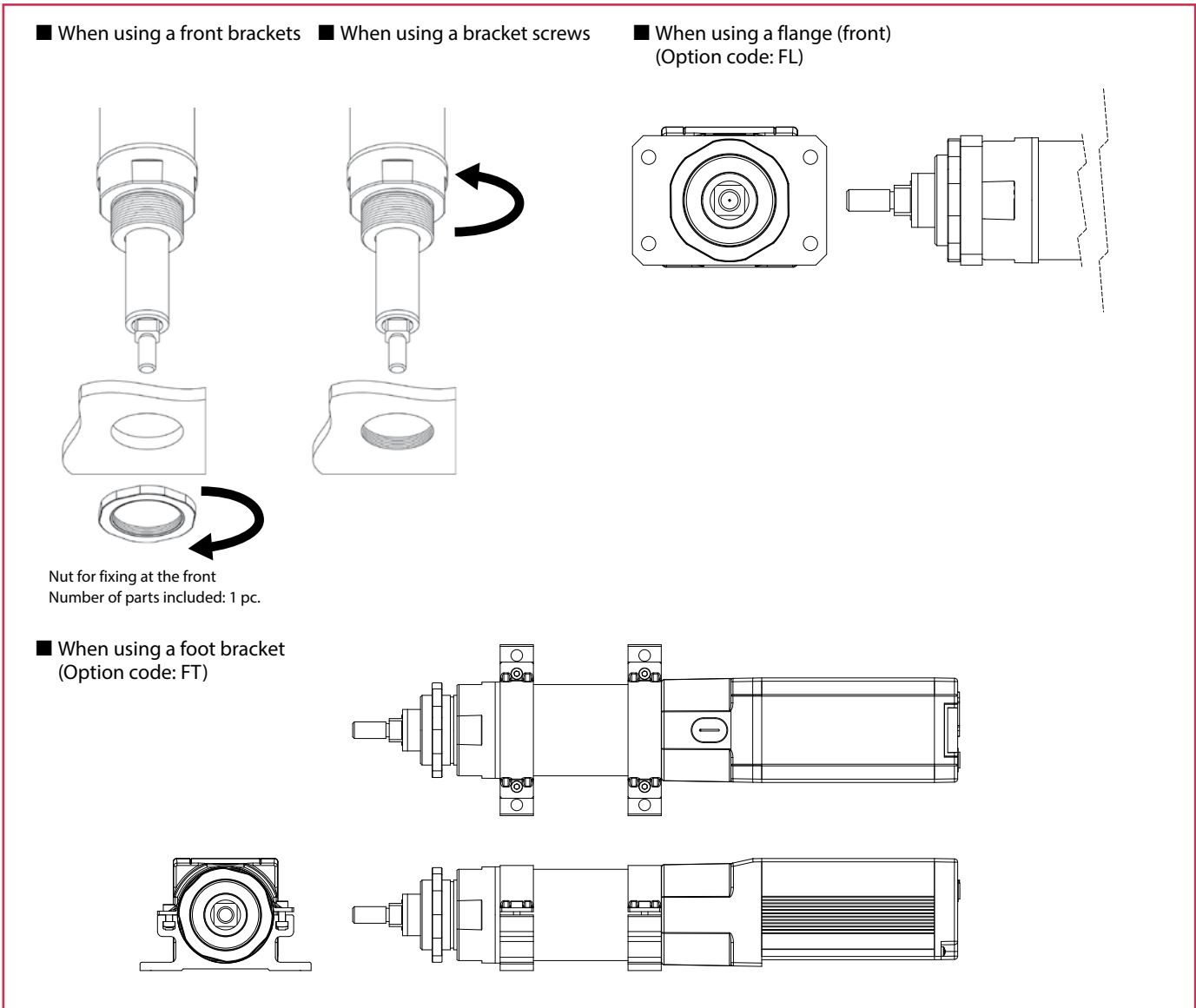

Mounting method

Radial Cylinder (RR3/RR4/RR6/RR7)

■ When using a square nuts

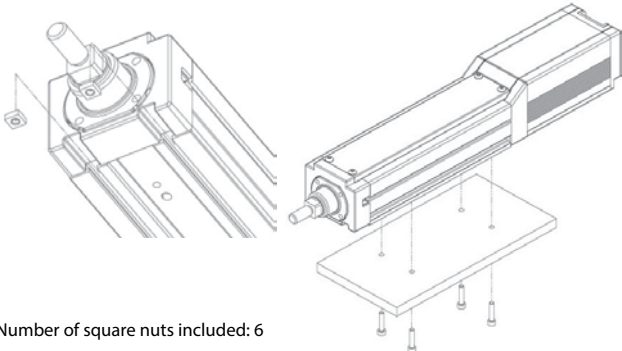

Number of square nuts included: 6

■ When using a foot brackets
(Option code: FT)

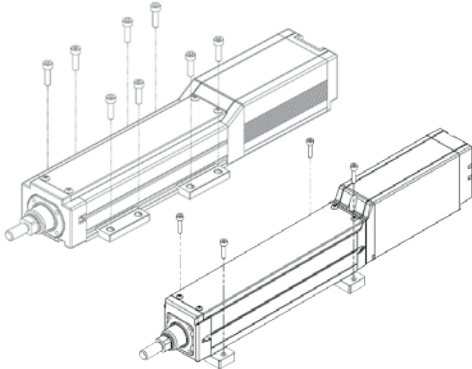

■ When using a front brackets

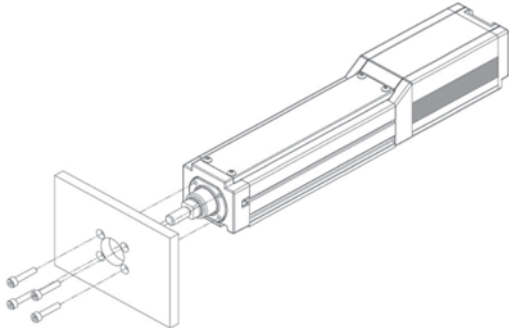

■ When using a flange (front)
(Option code: FL)

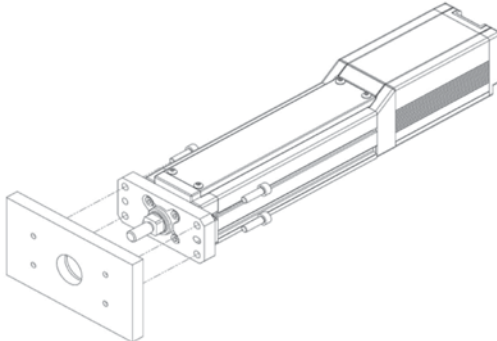

Radial Cylinder motor side-mounted specification (RR6□R/RR7□R)

■ When using a square nuts

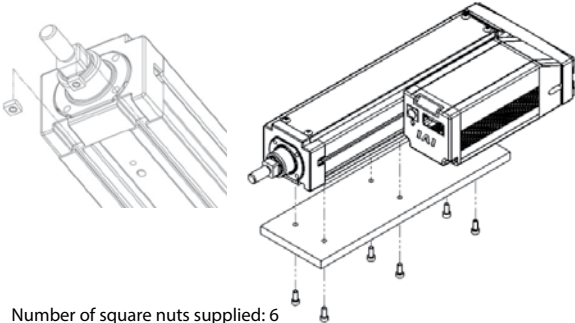

Number of square nuts supplied: 6

■ When using a foot brackets (Option code: FT)

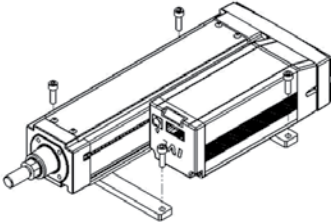

■ When using a front bracket

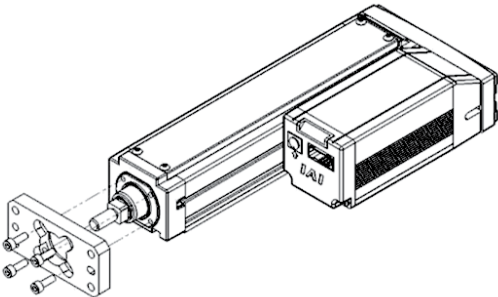

■ When using a flange (front) (Option code: FL)

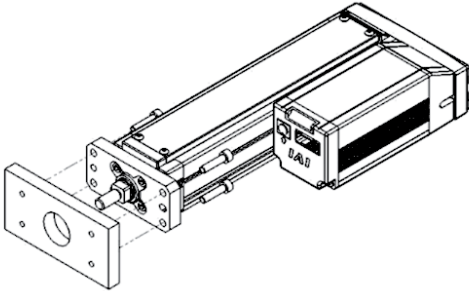

High Rigidity Radial Cylinder (RR6□AH/RR7□AH)

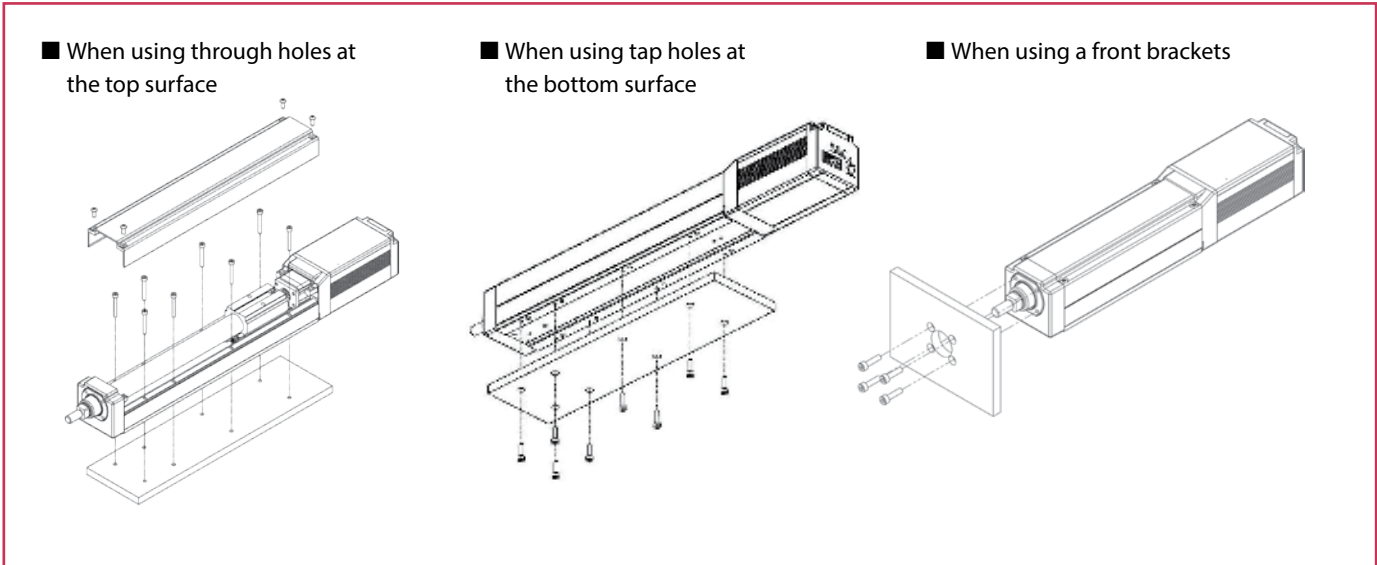

High Rigidity Radial Cylinder motor side-mounted specification (RR6□AHR/RR7□AHR)

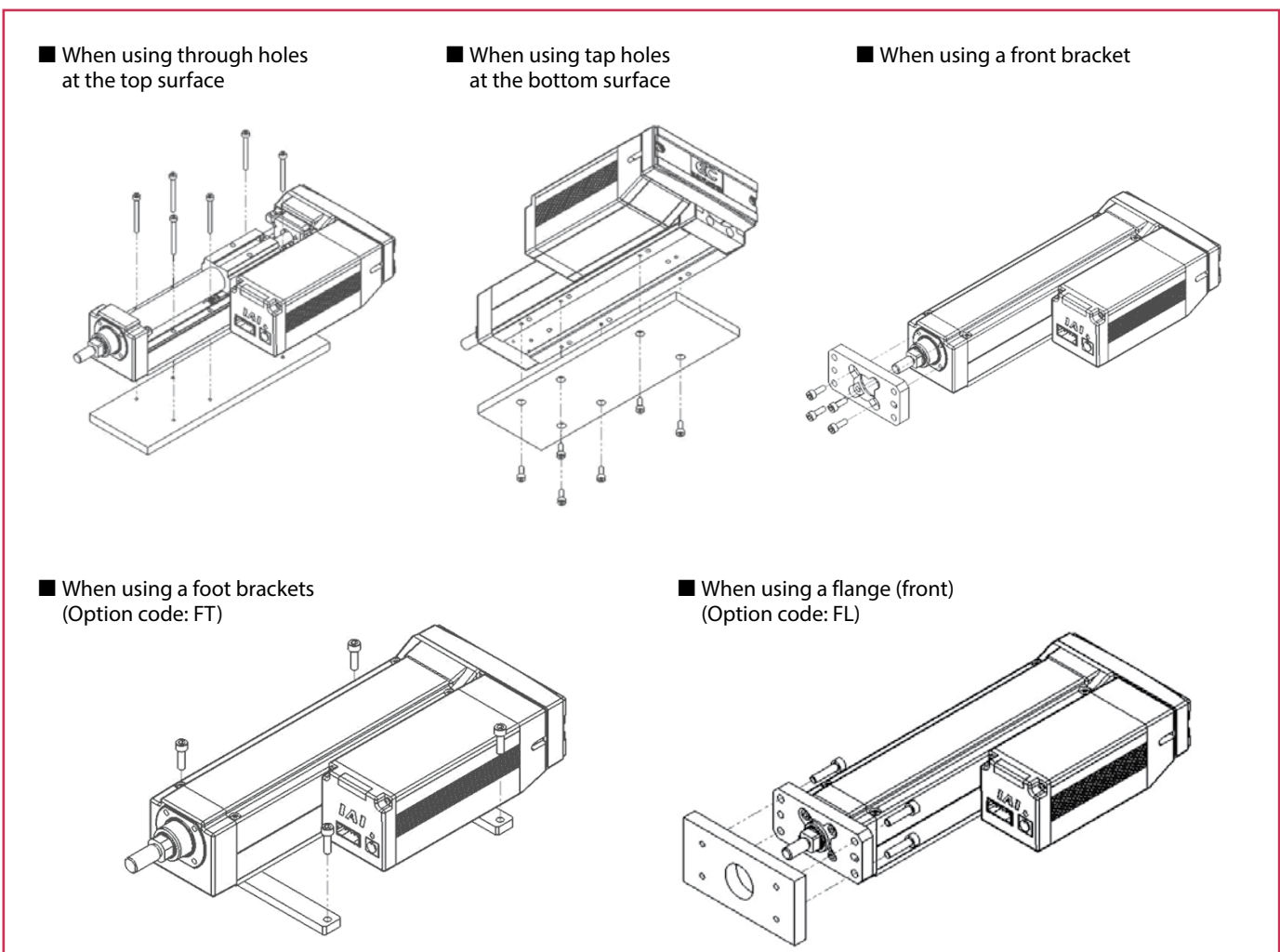

Mini Rod type (RP)

* Be sure to provide an exterior rotation stop.

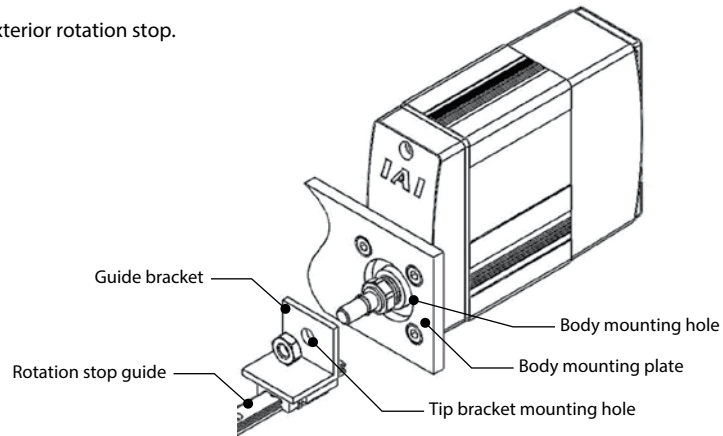

Mini Rod type (GS/GD)

●GS

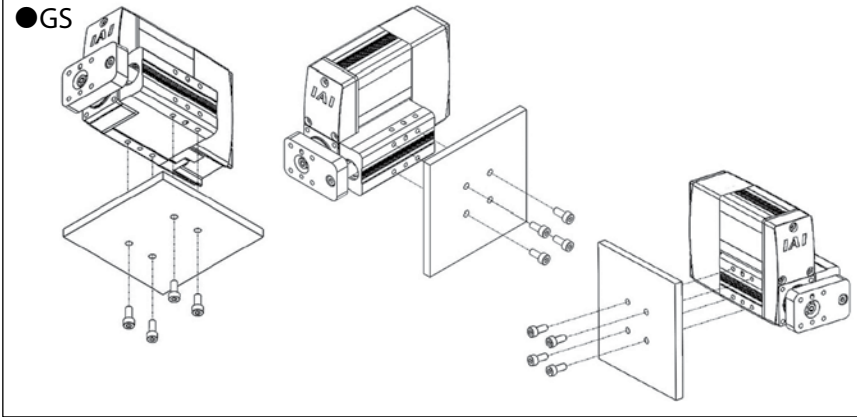

●GD

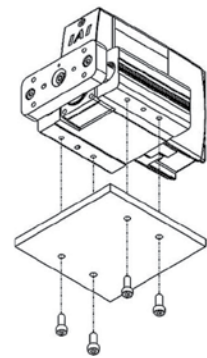

Mini Table type (TC/TW)

●TC

(Options GT2 and GT4)

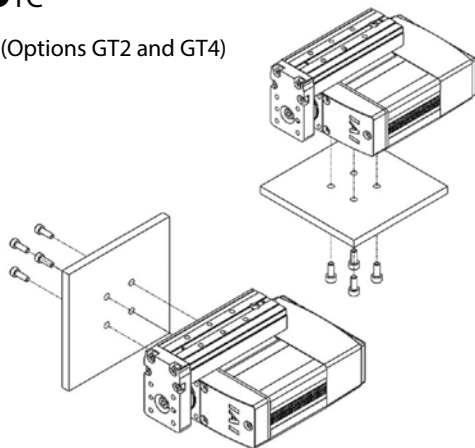

(Option GT3)

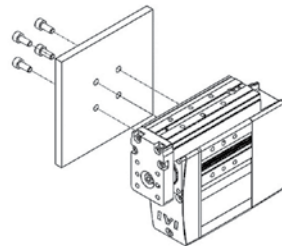

* Mounting from the opposite side is also possible.

●TW

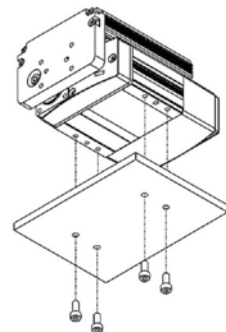

Precautions for Installation

Overall

- For vertical mounting, it is recommended to have the motor installed on top.
While installing the motor on the bottom will not cause problems during normal operation, after a long period of time the grease can separate, flow into the motor unit, and cause problems on rare occasions.

Slider, High Rigidity Slider, Radial Cylinder, High rigidity Radial Cylinder, Rod (GS4/GD4), Table

- Keep the body installation surface and workpiece mounting surface flatness at 0.05mm/m or lower.
Uneven flatness will increase the slider's sliding resistance and may cause malfunction.

Slider, High Rigidity Slider

- While installation in side and ceiling mount orientations are possible, this may cause slack or misalignment in the stainless steel sheet. Continued use in these orientations can cause the stainless steel sheet to break. Please inspect it daily and adjust the sheet if any slack or misalignment is found.

Slider, Radial Cylinder

- Since the actuator cannot be accurately positioned in the width direction when fixing with side blocks (foot bracket: FT), use positioning pins, etc.

To mount:

- (1) Press the reference surface of the actuator against the positioning pin, etc.
- (2) Maintaining the pressure, fix side block A on the opposite side.
- (3) Finally, fix side block B on the positioning pin side.

* Note that there may be cases where sufficient fastening force cannot be obtained when mounting with methods other than the procedure above.

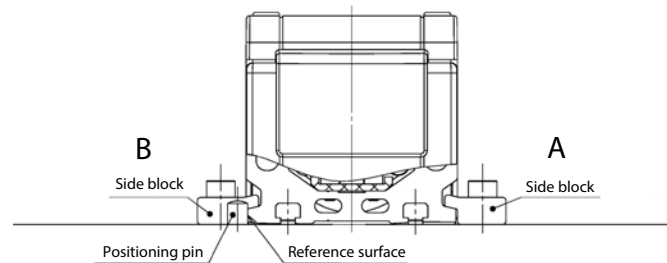

Radial Cylinder, High rigidity Radial Cylinder

- It is recommended that when radial load and moment are applied, all of the bottom surface of the base be fixed.
When fixing the front bracket, the product body will be deflected or warped due to radial load and moment, causing vibration, shorter service life and troubles.
- For the minimum stroke of the side-mounted specification, when both the brake option and the flange (front) option are selected, the fixing bolts may not go into place because there is no space between the flange mounting surface and the motor.

High rigidity slider type side-mounted motor specification, High rigid Radial Cylinder side-mounted motor specification

- For the side-mounted motor specification, the motor side cover cannot be removed when the stroke is less than 200mm.
When using the through bolt holes at the top surface, either the front bracket or motor unit assy should be removed.
If neither one is removed, please mount it from the top surface by using the foot bracket (option code: FT).

Rod, Radial Cylinder, High rigidity Radial Cylinder

- Do not attempt to apply any external force to the body during front bracket mounting or flange (front) mounting. External force may cause malfunctions or damage to parts.

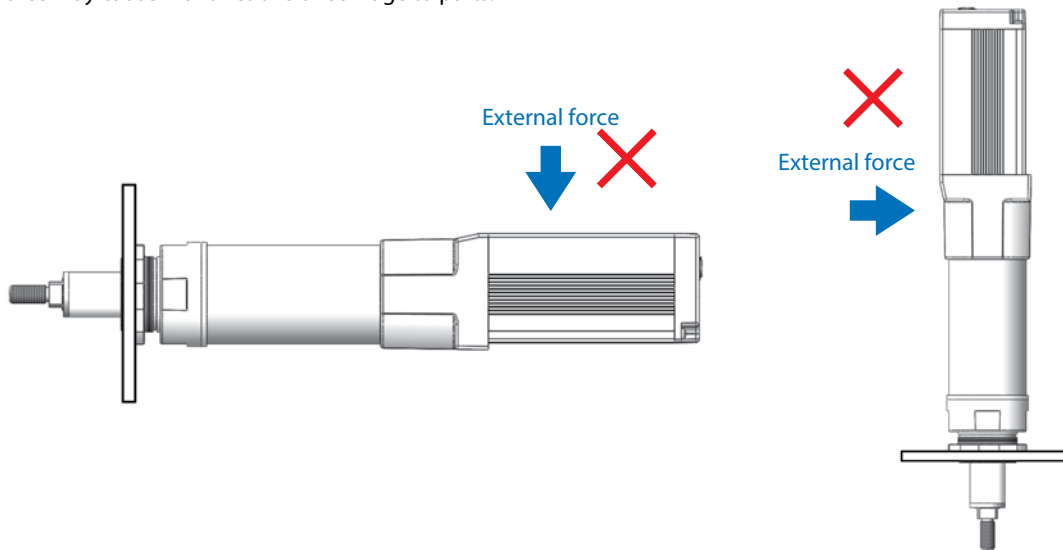

- When using front bracket mounting, flange (front) mounting, etc., if the device is mounted horizontally, fixed at a single point and has a stroke of 150mm or more, prepare a support block as shown in the figure below even if there is no external force applied on the body. Even when the stroke is under 150mm stroke, a support block is strongly recommended in order to avoid vibration generated due to the operation conditions or installation environment, which may lead to abnormal operation or damage to parts. For the support block, we recommend either using the optional foot bracket or keeping the support block (aluminum alloy, etc.) close against the block. The installation position should be on the frame motor side.

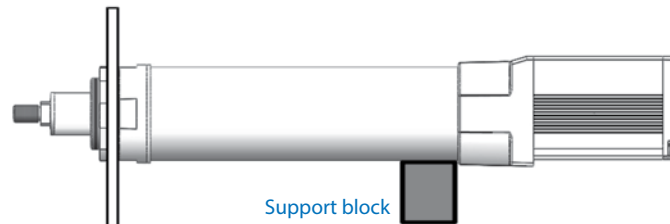

[Notes for using external guide with rod type]

- Parallelism of actuator and external guide
 - When using an external guide, parallel misalignment (in the horizontal and vertical planes) between the actuator and the external guide could result in malfunction, premature wear, or damage to the actuator. When mounting a guide, align the center of the actuator parallel to the guide. Following the installation, make sure that the sliding resistance is constant over the entire stroke.

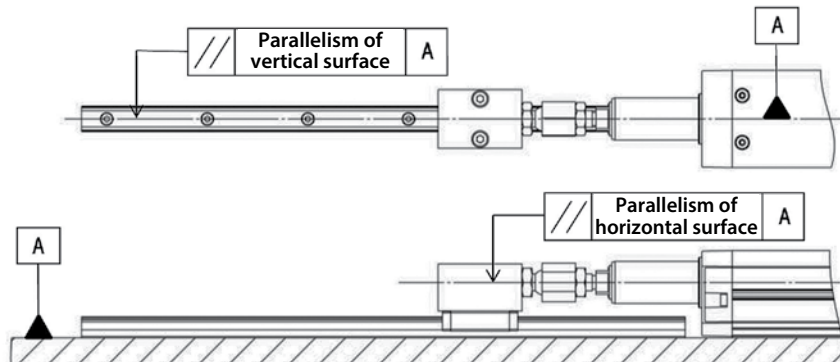

Precautions for Installation

● External guide fixing method

Even when parallelism of the guide and the actuator has been adjusted, incorrect fixing risks premature damage to the actuator. See below:

Rod type

The rod type actuator cannot accept a rotational force on the rod. "Rigid fixing" of an external guide is recommended, to restrict rotation of the rod. A "floating joint" which does not restrict rotation of the rod will create force on the rotation stop during operation. This could result in premature wear on the rotation stop. (Floating joints with rotation direction restrictions are acceptable.)

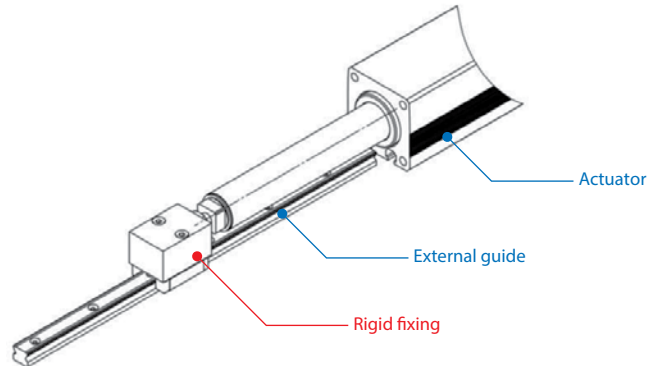

Radial Cylinder, High rigidity Radial Cylinder

"Floating joint" is recommended for the external guide fixing method. The floating joint absorbs the misalignment between the built-in guide and external guide, making adjustment easier. With "rigid fixing," it is difficult to adjust the parallelism between the built-in guide and external guide: even a minute deviation in parallelism applies load to the guide, which may cause premature damage.

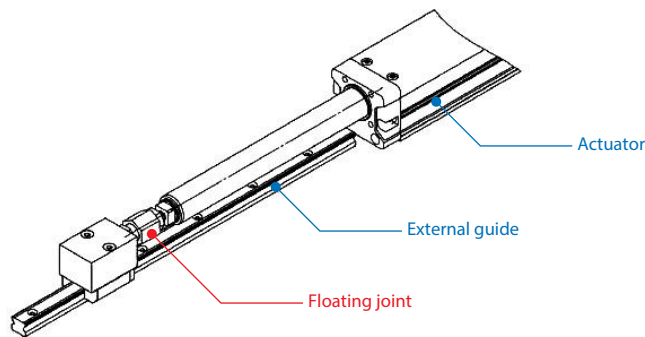

Overhang Load Length (ℓ)

When a workpiece or a bracket is mounted at an offset distance from the actuator slider, the overhang load length indicates the recommended offset at which the actuator can operate smoothly. Be sure to keep the overhang load length within the recommended value, as exceeding the recommended value may cause malfunction due to vibration, etc. For details on the numerical values, refer to the applicable page for each model.

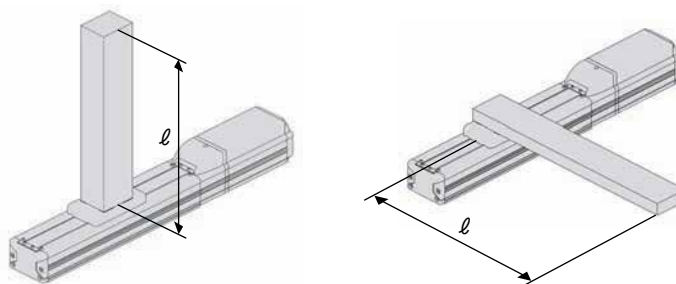

Operational Life

Operational life of a linear guide represents the total distance that can be traveled, without flaking, by 90% of a group of products that are operated separately under the same conditions. The operational life calculation method is as follows.

Operational life calculation method

Operational life of a linear guide can be calculated with the following formula using the allowable dynamic moment that is determined for each model.

$$L = \left(\frac{C_M}{M} \right)^3 \cdot URL$$

L: Operational Life (km), C_M : Allowable Dynamic Moment (N·m),
M: Acting moment (N·m), URL: Standard rated life (km)

For applications where the operational life may be decreased from vibrations and installation conditions, the operational life is calculated with the following formula.

$$L = \left(\frac{C_M}{M} \cdot \frac{f_{ws}}{f_w} \cdot \frac{1}{f_a} \right)^3 \cdot URL$$

L: Service Life (km), C_M : Allowable Dynamic Moment (N·m), M: Acting moment (N·m),
 f_{ws} : Standard load coefficient, f_w : Load coefficient, f_a : Attachment coefficient, URL: Standard rated life

The load coefficient f_w is a coefficient for taking into account the decrease in life from operating conditions. The standard load coefficient f_{ws} is a standard value of the load coefficient that is determined for each model. This coefficient is generally 1.2, but in the case that it is not 1.2, it is indicated in the specification of that model. The attachment coefficient f_a is a coefficient for taking into account the decrease in life from the attachment condition of the actuator.

Load Coefficient

Operating Condition	Load coefficient f_w	Acceleration/Deceleration Guideline
Little vibration/impact, slow operation	1.0-1.5	(Less than 1.0G)
Moderate vibration/impact, sudden braking/acceleration	1.5-2.0	1.0G-2.0G
Large vibration/impact with sudden acceleration/deceleration	2.0-3.0	(Greater than 2.0G)

Attachment Coefficient

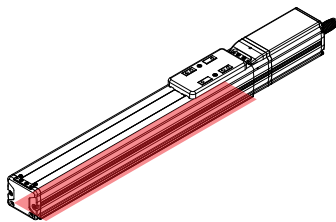
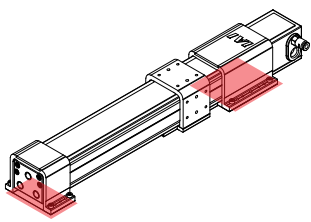
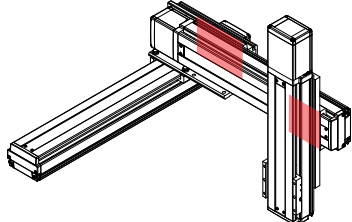
Attachment Condition			
	Fixing entire surface	Fixing at both ends	Fixing sections
Attachment coefficient F_a	1.0	1.2	1.5

* As a general rule, please use every tapped hole on the mounting surface.

* Even when mounting the entire surface, please use the attachment coefficients of 1.2 or 1.5 depending on the length of the bolt for fixing.

Operational Life

The formula shows that the service life depends on the acting moment. With a light load, the service life will be longer than the standard rated life. For example, when a moment of $0.5C_M$ (half of the allowable dynamic moment) acts on a model with a standard rated life of 5,000 km, the diagram below shows that the service life becomes 40,000 km, which is 8 times the standard rated life.

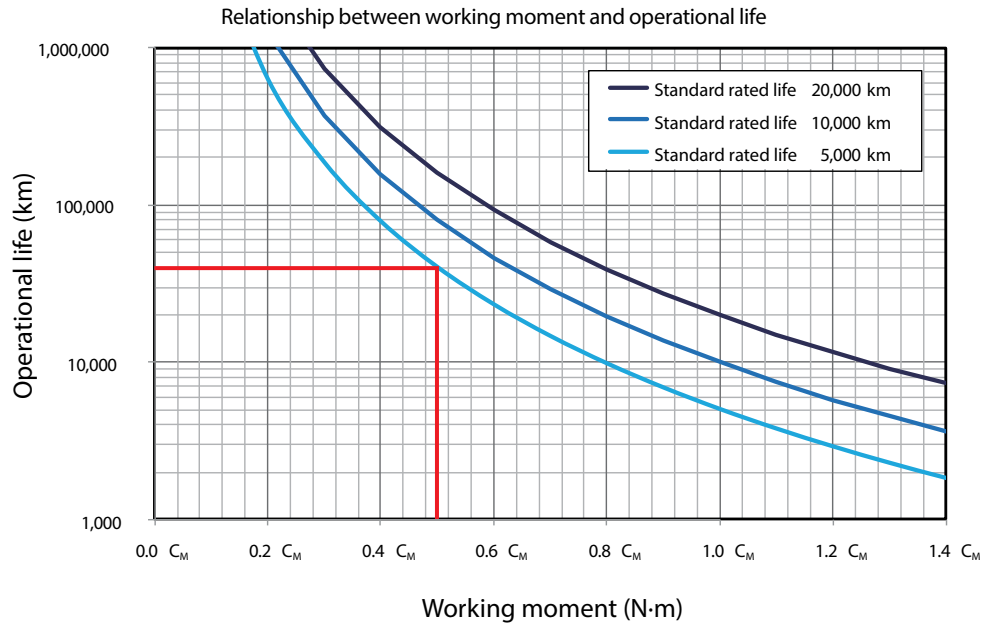

* It is assumed that $f_{WS}=f_W$ and $f_a=1.0$, and C_M indicates allowable dynamic moment.

Example calculation of service life

An example service life will be calculated using the operation conditions below.

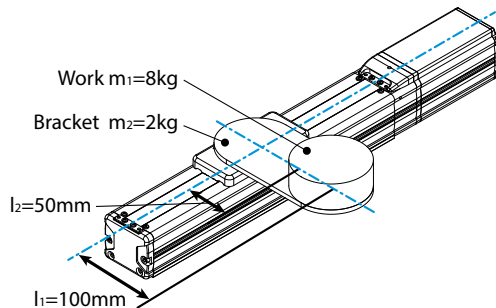

Model	RCP5-SA6C-WA-42P-6
Installation Condition	Horizontal Installation
Attachment Condition	Fixing entire surface
Controller	PowerCON specification
Acceleration/Deceleration	0.5G

m_1 : mass of work
 m_2 : mass of bracket

l_1 : Distance to the center of gravity of the work
 l_2 : Distance to the center of gravity of the bracket

Since moment acting in the M_c direction of the actuator is the dominant one, calculation will be made using the moment acting in the M_c direction. Moment acting in the M_c direction is calculated as follows.

$$M = \left(m_1 \times 9.8 \times \frac{l_1}{1,000} \right) + \left(m_2 \times 9.8 \times \frac{l_2}{1,000} \right) = \left(8 \times 9.8 \times \frac{100}{1,000} \right) + \left(2 \times 9.8 \times \frac{50}{1,000} \right) = 8.82 \text{ N}\cdot\text{m}$$

The load coefficient will be 1.25 since acceleration/deceleration is 0.5G. The attachment coefficient will be 1.0 since the attachment condition is fixing the entire surface. For this model, the allowable dynamic moment in the M_c direction is 24.6 N·m, the standard rated life is 5,000km, and the standard load coefficient is 1.2, so the service life is calculated as follows.

$$L = \left(\frac{C_M}{M} \cdot \frac{f_{WS}}{f_W} \cdot \frac{1}{f_a} \right)^3 \cdot \text{URL} = \left(\frac{24.6 \text{ N}\cdot\text{m}}{8.82 \text{ N}\cdot\text{m}} \times \frac{1.2}{1.25} \times \frac{1}{1} \right)^3 \times 5,000 \text{ km} = 95,980 \text{ km}$$

This shows that the service life for the above operation conditions is 95,980 km.

MEMO

A series of horizontal dotted lines for writing.

EC-S3

Simple
dust-
proof

Coupled
Motor

Body width
40
mm

24v
Stepper
motor

Model Specification Items

EC — **S3**

Series	Type	Lead	Stroke	Cable Length	Options	
		H 6mm M 4mm L 2mm	50 300	50mm 300mm (per 50mm)	0 Terminal type with connector 1 1m 2 2m 10 10m	Refer to the option price list below

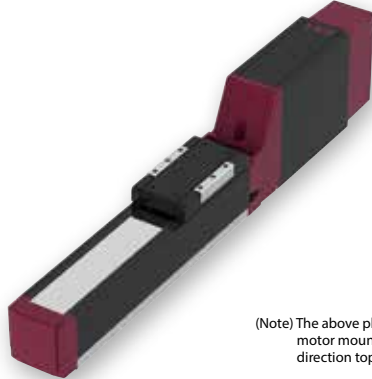
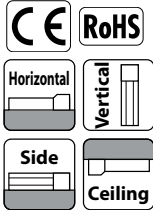

(Note) The above photo shows motor mounting direction top (MOT).

- POINT
Selection
Notes

 - (1) The actuator specifications display the payload's maximum value, but it will vary depending on the acceleration and speed. Please refer to "Table of Payload by Speed/Acceleration" for more details.
 - (2) When performing a push-motion operation, please refer to the "Correlation between push force and current limit value." Push force is only a guide. Please refer to P115 for cautions.
 - (3) Special attention needs to be paid to the mounting orientation. Please refer to P33 for details.
 - (4) Reference value of the overhang load length is under 100mm in the Ma, Mb and Mc directions. Please refer to the illustration on P35 for the overhang load length.
 - (5) The center of gravity of the attached object should be less than 1/2 of the overhang distance. Even when the overhang distance and load moment are within the allowable range, the operating conditions should be moderated if some abnormal vibration or noise is observed.

Stroke			
Stroke (mm)	EC-S3	Stroke (mm)	EC-S3
50	○	200	○
100	○	250	○
150	○	300	○

Stroke and maximum speed					
Lead (mm)	50-150 (per 50mm)	200 (mm)	250 (mm)	300 (mm)	
6	420	300	210	150	
4	280	200	140	100	
2	140	100	70	50	(unit is mm/s)

Cable length	
Cable code	Cable length
0	No cable (connector supplied)
1 ~ 3	1 ~ 3m
4 ~ 5	4 ~ 5m
6 ~ 10	6 ~ 10m

(Note) Robot cables.

Options		
Name	Option code	Reference page
Brake	B	See P.101
Foot bracket	FT	See P.103
Motor mounting direction change (bottom) (Note 1)	MOB	See P.105
Motor mounting direction change (left) (Note 1)	MOL	See P.105
Motor mounting direction change (right) (Note 1)	MOR	See P.105
Motor mounting direction change (top) (Note 1)	MOT	See P.105
Non-motor end specification	NM	See P.108
PNP specification	PN	See P.108
Split motor and controller power supply specification	TMD2	See P.109
Battery-less absolute encoder	WA	See P.109
Wireless communication specification	WL	See P.109
Wireless axis-operation specification	WL2	See P.109

(Note 1) Please make sure to enter a code in the option column of the model spec item.

Main specifications

Item		Description			
Lead	Ball screw lead (mm)	6	4	2	
	Max. payload (kg)	3.5	6	9	
Horizontal	Max. speed (mm/s)	420	280	140	
	Min. speed (mm/s)	8	5	3	
	Rated acceleration/deceleration (G)	0.3	0.3	0.3	
	Max. acceleration/deceleration (G)	0.5	0.3	0.3	
Vertical	Max. payload (kg)	1.5	2.5	3.5	
	Max. speed (mm/s)	420	280	140	
	Min. speed (mm/s)	8	5	3	
	Rated acceleration/deceleration (G)	0.3	0.3	0.3	
Push force	Max. acceleration/deceleration (G)	0.3	0.3	0.3	
	Max. thrust force when pushing (N)*	45	68	136	
Brake	Max. speed when pushing (mm/s)	20	20	20	
	Brake specification	Non-excitation actuating solenoid brake			
Stroke	Brake holding force (kgf)	1.5	2.5	3.5	
	Min. stroke (mm)	50	50	50	
	Max. stroke (mm)	300	300	300	
	Stroke pitch (mm)	50	50	50	

* Speed limitation applies to push motion. See the manual or contact IAI.

Item	Description
Driving system	Ball screw ϕ 6mm, Rolling C10
Positioning repeatability	\pm 0.05mm
Lost motion	—
Base	Dedicated aluminum extruded material (A6063SS-T5 or equivalent) Black alumite treatment
Linear guide	Linear motion infinite circulating type
Static allowable moment	Ma: 9N·m
	Mb: 13N·m
	Mc: 15N·m
Dynamic allowable moment (Note 2)	Ma: 3N·m
	Mb: 5N·m
	Mc: 6N·m
Ambient operation temperature/humidity	0 to 40°C, RH 85% or less (Non-condensing)
Degree of protection	IP20
Vibration & shock resistance	4.9m/s ² 100Hz or less
Overseas standards	CE Marking, RoHS (Restriction of Hazardous Substances)
Motor type	Stepper motor
Encoder type	Incremental / battery-less absolute
Number of encoder pulses	800 pulse /rev.

(Note 2) Based on the standard rated operation life of 5,000 km. Operation life varies depending on operating and mounting conditions. Confirm the operation life on P36.

Table of Payload by Speed and Acceleration/Deceleration

The unit for payload is kg.

Lead 6				Lead 4				Lead 2				
Speed (mm/s)	Acceleration (G)			Speed (mm/s)	Acceleration (G)			Speed (mm/s)	Acceleration (G)			
	0.3	0.5	0.3		0.3	0.3	0.3		0.3	0.3	0.3	
0	3.5	3	1.5	0	6	2.5	0	9	3.5	0	9	3.5
120	3.5	3	1.5	80	6	2.5	40	9	3.5	40	9	3.5
210	3.5	3	1.5	140	6	2.5	70	9	3.5	70	9	3.5
255	3.5	3	1.5	170	6	2.5	85	9	3.5	85	9	3.5
315	3.5	3	1.5	210	6	2.5	105	9	3.5	105	9	3.5
360	3.5	3	1.5	240	5.5	2.5	120	9	3	120	9	3
420	3	2.5	1	280	4.5	2	140	8	2.5	140	8	2.5

Correlation between push force and current limit value

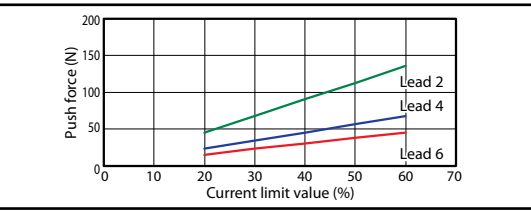

Direction of slider type moment

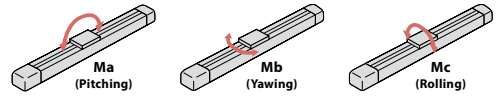

■ Dimensions by Stroke

Stroke		50	100	150	200	250	300	
L	Incremental	without brake	268	318	368	418	468	518
		with brake	293	343	393	443	493	543
	Battery-less absolute	without brake	293	343	393	443	493	543
		with brake	313	363	413	463	513	563

■ Mass by Stroke

Stroke	50	100	150	200	250	300
A	143	193	243	293	343	393
B	114	164	214	264	314	364
J	50	100	150	200	250	300

Stroke		50	100	150	200	250	300
Weight (kg)	without brake	0.7	0.8	0.9	1.0	1.1	1.2
	with brake	0.8	0.9	1.0	1.1	1.2	1.3

Dimensions

(Note) When the slider is returning to its home position, please be careful of interference from surrounding objects, as it will travel until it reaches the M.E.

(Note) The drawing below represents motor mounting direction top (MOT).

CAD drawings can be downloaded from our website.
www.intelligentactuator.com

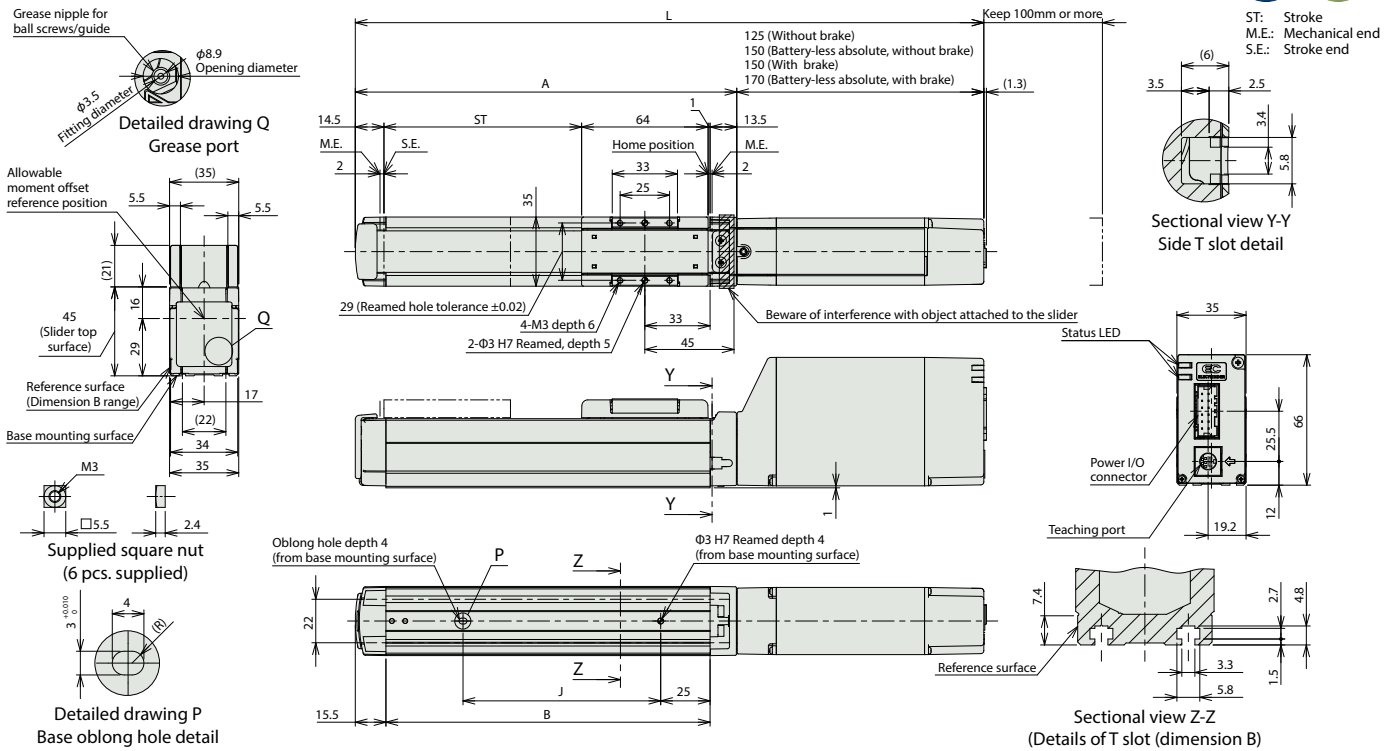

■ Change of motor mounting direction (optional)

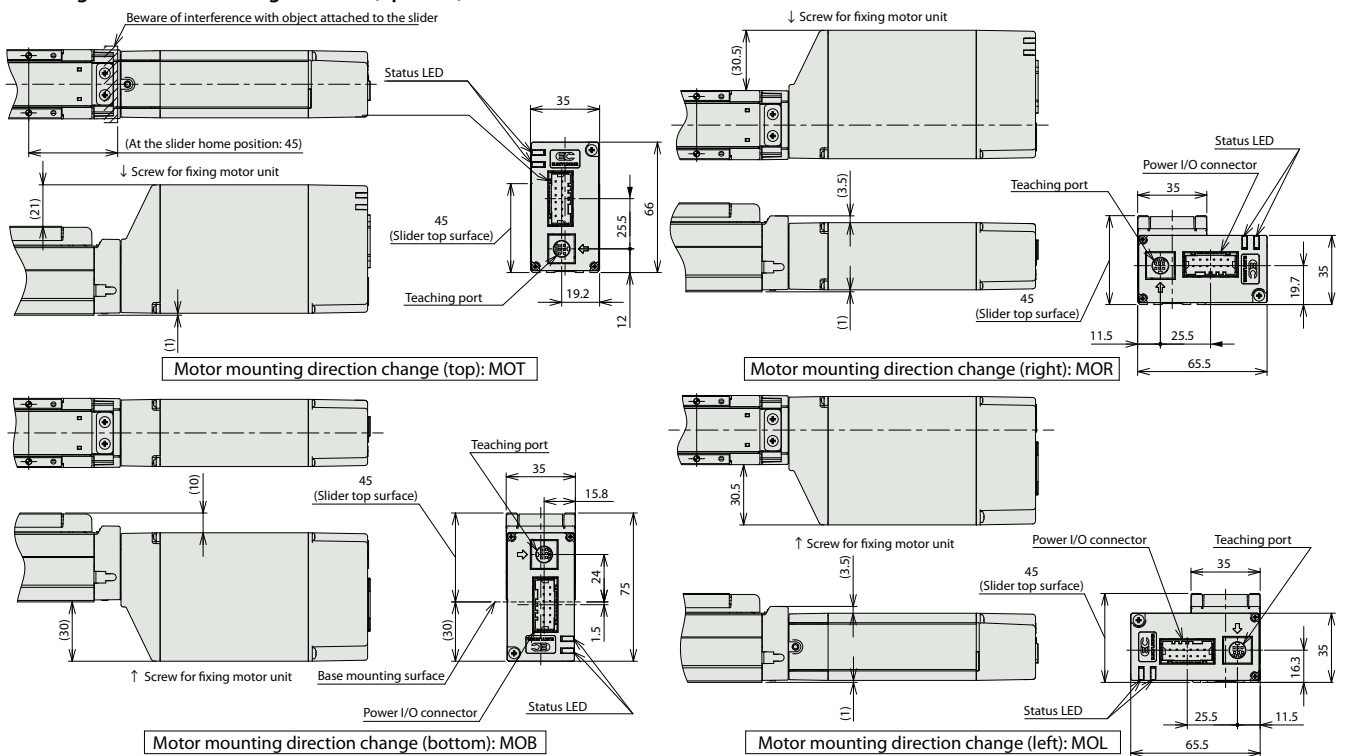

Applicable controller

(Note) The EC series is equipped with a built-in controller. Please refer to P116 for details.

EC-S4

Simple
dust-
proof

Coupled
Motor

Body width
40 mm

24v
Stepper
motor

Model Specification Items

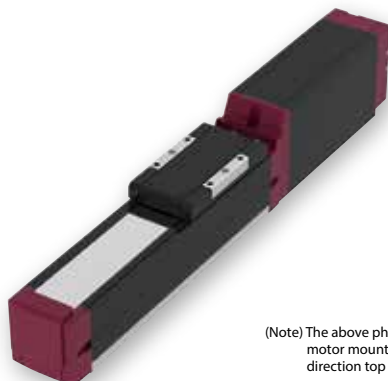
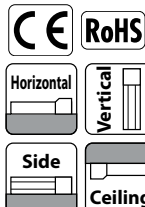
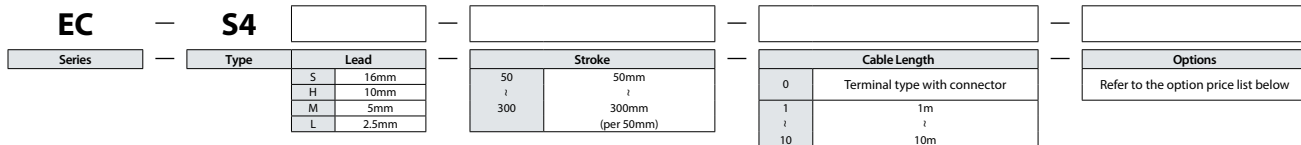

(Note) The above photo shows motor mounting direction top (MOT).

- POINT Selection Notes**
- The actuator specifications display the payload's maximum value, but it will vary depending on the acceleration and speed. Please refer to "Table of Payload by Speed/Acceleration" for more details.
 - When performing a push-motion operation, please refer to the "Correlation between push force and current limit value." Push force is only a guide. Please refer to P115 for cautions.
 - Special attention needs to be paid to the mounting orientation. Please refer to P33 for details.
 - Reference value of the overhang load length is under 100mm in the Ma, Mb and Mc directions. Please refer to the illustration on P35 for the overhang load length.
 - The center of gravity of the attached object should be less than 1/2 of the overhang distance. Even when the overhang distance and load moment are within the allowable range, the operating conditions should be moderated if some abnormal vibration or noise is observed.

Stroke			
Stroke (mm)	EC-S4	Stroke (mm)	EC-S4
50	○	200	○
100	○	250	○
150	○	300	○

Stroke and maximum speed				
Lead (mm)	Energy-saving	50-200 (per 50mm)	250 (mm)	300 (mm)
16	disabled	800	760	540
	enabled	800 <560>	760 <560>	540
10	disabled	700	470	320
	enabled	525	470	320
5	disabled	350	240	160
	enabled	260	240	160
2.5	disabled	175 <150>	120	85
	enabled	135	120	85

Price List for cable length	
Cable code	Cable length
0	No cable (connector supplied)
1 ~ 3	1 ~ 3m
4 ~ 5	4 ~ 5m
6 ~ 10	6 ~ 10m

(Note) Robot cables.

Figures in < > represent vertical operations.

(Unit is mm/s)

Options		
Name	Option code	Reference page
Brake	B	See P.101
Foot bracket	FT	See P.103
Motor mounting direction change (bottom) (Note 1)	MOB	See P.105
Motor mounting direction change (left) (Note 1)	MOL	See P.105
Motor mounting direction change (right) (Note 1)	MOR	See P.105
Motor mounting direction change (top) (Note 1)	MOT	See P.105
Non-motor end specification	NM	See P.108
PNP specification	PN	See P.108
Split motor and controller power supply specification	TMD2	See P.109
Battery-less absolute encoder	WA	See P.109
Wireless communication specification	WL	See P.109
Wireless axis-operation specification	WL2	See P.109

(Note 1) Please make sure to enter a code in the option column of the model spec item.

Main specifications

Item		Description				
Lead	Ball screw lead (mm)	16	10	5	2.5	
	Payload	Max. payload (kg) (energy-saving disabled)	7	12	15	18
		Max. payload (kg) (energy-saving enabled)	4	10	12	14
Horizontal	Speed/Acceleration/Deceleration	Max. speed (mm/s)	800	700	350	175
		Min. speed (mm/s)	40	30	7	4
		Rated acceleration/deceleration (G)	0.3	0.3	0.3	0.3
		Max. acceleration/deceleration (G)	1	1	0.5	0.3
	Vertical	Payload	Max. payload (kg) (energy-saving disabled)	1.5	2.5	5
Max. payload (kg) (energy-saving enabled)			1	2	4.5	6.5
Speed/Acceleration/Deceleration		Max. speed (mm/s)	800	700	350	150
		Min. speed (mm/s)	40	30	7	4
Push force	Speed/Acceleration/Deceleration	Rated acceleration/deceleration (G)	0.3	0.3	0.3	0.3
		Max. acceleration/deceleration (G)	0.5	0.5	0.5	0.3
		Max. thrust force when pushing (N)*	41	66	132	263
Brake	Brake specification	Non-excitation actuating solenoid brake				
	Brake holding force (kgf)	1.5	2.5	5	6.5	
Stroke	Min. stroke (mm)	50	50	50	50	
	Max. stroke (mm)	300	300	300	300	
	Stroke pitch (mm)	50	50	50	50	

* Speed limitation applies to push motion. See the manual or contact IAI.

Item		Description	
Driving system		Ball screw ϕ 8mm, Rolling C10	
Positioning repeatability		\pm 0.05mm	
Lost motion		—	
Base		Dedicated aluminum extruded material (A6063SS-T5 or equivalent) Black alumite treatment	
Linear guide		Linear motion infinite circulating type	
Static allowable moment		Ma:	13N·m
		Mb:	18N·m
		Mc:	25N·m
Dynamic allowable moment (Note 2)		Ma:	5N·m
		Mb:	7N·m
		Mc:	9N·m
Ambient operation temperature/humidity		0 to 40°C, RH 85% or less (Non-condensing)	
Degree of protection		IP20	
Vibration & shock resistance		4.9m/s ² 100Hz or less	
Overseas standards		CE Marking, RoHS (Restriction of Hazardous Substances)	
Motor type		Stepper motor	
Encoder type		Incremental / battery-less absolute	
Number of encoder pulses		800 pulse / rev.	

(Note 2) Based on the standard rated operation life of 5,000 km. Operation life varies depending on operating and mounting conditions. Confirm the operation life on P36.

Table of Payload by Speed and Acceleration/Deceleration

Energy-saving disabled

The unit for payload is kg. Operations in the blank locations are not possible

Lead 16				Lead 10				Lead 5				Lead 2.5									
Orientation	Horizontal			Vertical			Orientation	Horizontal			Vertical			Orientation	Horizontal			Vertical			
	Speed (mm/s)	Acceleration (G)		Speed (mm/s)	Acceleration (G)			Speed (mm/s)	Acceleration (G)		Posture		Speed (mm/s)		Acceleration (G)		Speed (mm/s)	Acceleration (G)			
0	0.3	0.5	0.7	1	0.3	0.5	0	12	11	10	10	2.5	2	0	15	14	5	4.5	0	18	6.5
140	7	6	6	5	1.5	1.25	175	12	11	10	10	2.5	2	85	15	14	5	4.5	40	18	6.5
280	7	6	6	5	1.5	1.25	350	12	11	10	9	2.5	2	130	15	14	5	4.5	85	18	6.5
420	7	6	6	5	1.5	1.25	435	12	11	9	8	2.5	2	215	15	14	5	4.5	105	18	6.5
560	7	6	5.5	5	1.5	1.25	525	11	9	7	6	2	2	260	15	14	5	4.5	135	18	6.5
700	6	5	4.5	4	1.5	1.25	600	10	7	5	4.5	2	1.5	300	15	14	4.5	4	150	18	6
800	4	3.5	3	1			700	4	2.5	2.5	1			350	13	12	4	3.5	175	18	

Energy-saving enabled

The unit for payload is kg. Operations in the blank locations are not possible

Lead 16				Lead 10				Lead 5				Lead 2.5										
Orientation	Horizontal			Vertical			Orientation	Horizontal			Vertical			Orientation	Horizontal			Vertical				
	Speed (mm/s)	Acceleration (G)		Speed (mm/s)	Acceleration (G)			Speed (mm/s)	Acceleration (G)		Posture		Speed (mm/s)		Acceleration (G)		Speed (mm/s)	Acceleration (G)				
0	4	3.5	1	0	10	8	2	0	12	4.5	0	14	4.5	0	14	4.5	0	14	6.5			
140	4	3.5	1	175	10	8	2	85	12	4.5	40	14	4.5	280	4	3.5	1	350	9	6	2	
280	4	3.5	1	350	9	6	2	130	12	4	85	14	4	420	4	3.5	1	435	7	5	1.5	
420	4	3.5	1	435	7	5	1.5	215	10	4	105	14	4	260	9	2.5	1	260	9	2.5	135	
560	4	3	1	525	5	2.5	1	260	9	2.5	135	14	4	300	15	14	4.5	4	150	18	6	
700	3	2																				
800																						

■ Direction of slider type moment

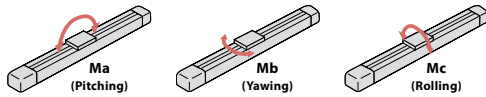

■ Mass by Stroke

Weight (kg)	Stroke						
	50	100	150	200	250	300	
	without brake	1.2	1.3	1.5	1.6	1.8	1.9
	with brake	1.3	1.5	1.6	1.8	1.9	2.1

■ Correlation between push force and current limit value

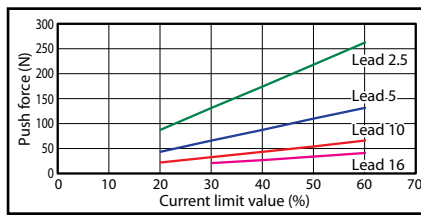

■ Dimensions by Stroke

Stroke		50	100	150	200	250	300	
L	Incremental	without brake	301	351	401	451	501	551
		with brake	331	381	431	481	531	581
L	Battery-less absolute	without brake	316	366	416	466	516	566
		with brake	346	396	446	496	546	596
A			166	216	266	316	366	416
B			134	184	234	284	334	384
J			100	150	200	250	300	350

■ Dimensions

*1 These dimensions are for the wireless communication or wireless axis-operation optional specifications.

(Note) When the slider is returning to its home position, please be careful of interference from surrounding objects, as it will travel until it reaches the M.E.

(Note) The drawing below represents motor mounting direction top (MOT).

CAD drawings can be downloaded from our website.

www.intelligentactuator.com

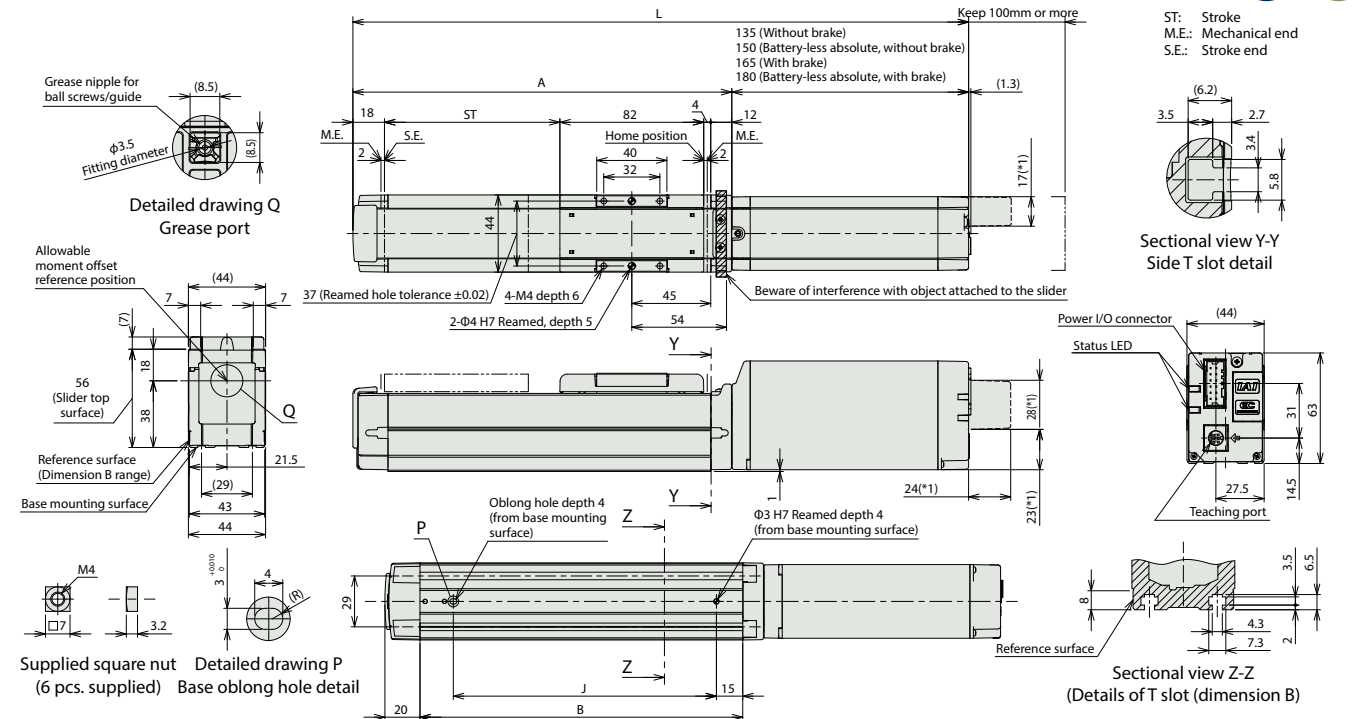

■ Motor mounting direction change (optional)

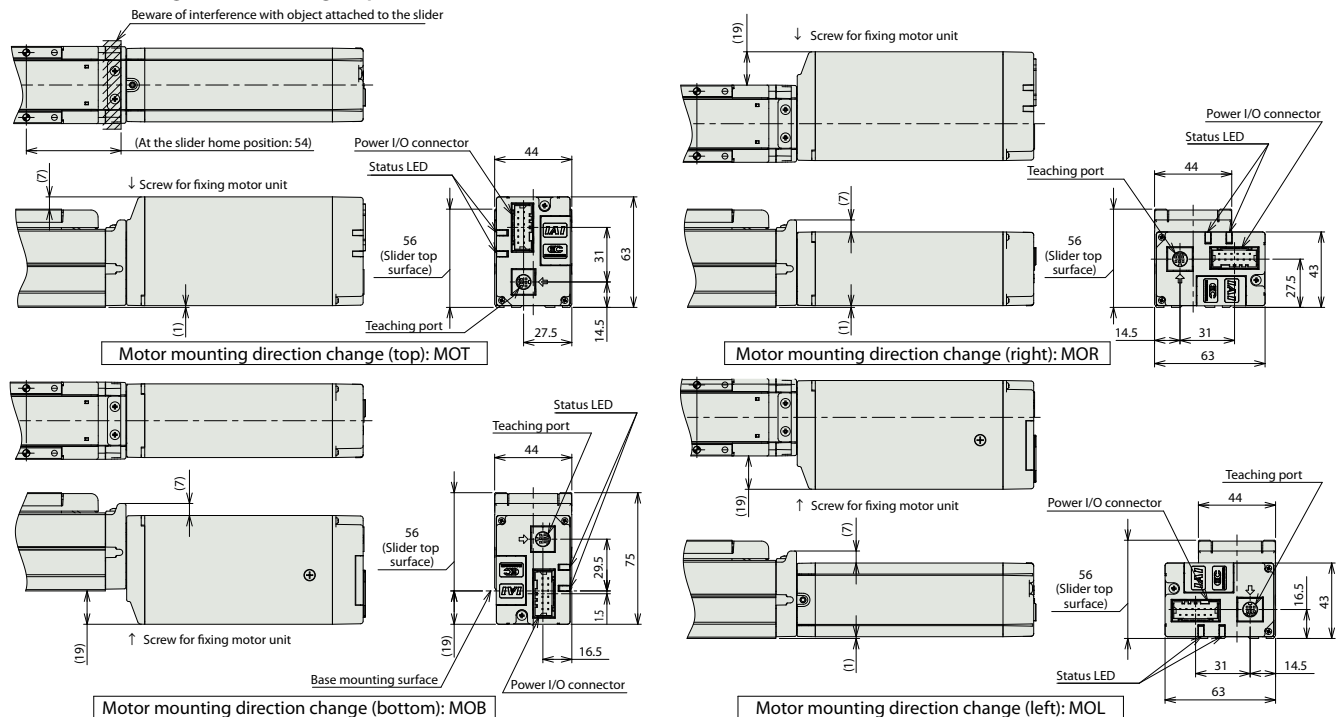

■ Applicable controller

(Note) The EC series is equipped with a built-in controller. Please refer to P116 for details.

EC-S6

Simple dust-proof

Coupled Motor

Body width 60 mm

24v Stepper motor

Model Specification Items

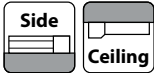
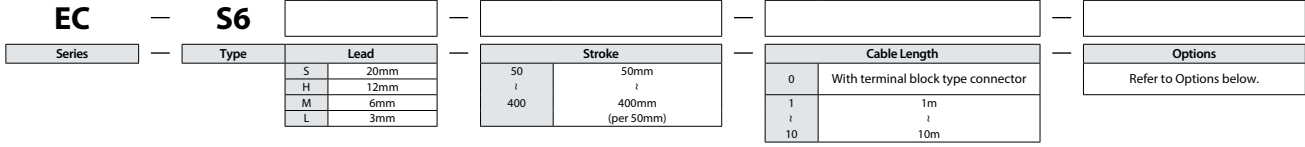

POINT Selection Notes

- (1) The actuator specifications display the payload's maximum value, but it will vary depending on the acceleration and speed. Please refer to "Table of Payload by Speed/Acceleration" for more details.
- (2) When performing a push-motion operation, please refer to the "Correlation between push force and current limit value." Push force is only a guide. Please refer to P115 for cautions.
- (3) Depending on the ambient operating temperature, duty control is necessary. Please refer to P109 for details.
- (4) Special attention needs to be paid to the mounting orientation. Please refer to P33 for details.
- (5) Reference value of the overhang load length is under 220mm in the Ma, Mb and Mc directions. Please refer to the illustration on P35 for the overhang load length.

Options

Type	Option code	Reference page
Brake	B	See P.101
Foot bracket	FT	See P.103
Non-motor end specification	NM	See P.108
PNP specification	PN	See P.108
Split motor and controller power supply specification	TMD2	See P.109
Battery-less Absolute Encoder specification	WA	See P.109
Wireless communication specification	WL	See P.109
Wireless axis-operation specification	WL2	See P.109

Cable Length

Cable code	Cable length
0	No cable (with connector)
1 ~ 3	1 ~ 3m
4 ~ 5	4 ~ 5m
6 ~ 10	6 ~ 10m

(Note) Robot cables.

Stroke

Stroke (mm)	EC-S6	Stroke (mm)	EC-S6
50	○	250	○
100	○	300	○
150	○	350	○
200	○	400	○

Main specifications

Item		Description			
Lead	Ball screw lead (mm)	20	12	6	3
	Max. payload (kg) (energy-saving disabled)	15	26	32	40
	Max. payload (kg) (energy-saving enabled)	8	14	20	25
	Min. speed (mm/s)	800	700	450	225
Horizontal Speed/acceleration/deceleration	Min. speed (mm/s)	25	15	8	4
	Rated acceleration/deceleration (G)	0.3	0.3	0.3	0.3
	Max. acceleration/deceleration (G)	1	1	1	1
	Max. payload (kg) (energy-saving disabled)	1	2.5	6	12.5
Vertical Payload	Max. payload (kg) (energy-saving enabled)	0.75	2	5	10
	Max. speed (mm/s)	800	700	450	225
Vertical Speed/acceleration/deceleration	Min. speed (mm/s)	25	15	8	4
	Rated acceleration/deceleration (G)	0.3	0.3	0.3	0.3
	Max. acceleration/deceleration (G)	0.5	0.5	0.5	0.5
	Pushing max. thrust force (N)*	67	112	224	449
Push force	Pushing max. speed (mm/s)	20	20	20	20
	Brake holding specification	Non-excitation actuating solenoid brake			
Brake	Brake holding force (kgf)	1	2.5	6	12.5
	Min. stroke (mm)	50	50	50	50
Stroke	Max. stroke (mm)	400	400	400	400
	Stroke pitch (mm)	50	50	50	50

* Speed limitation applies to push motion. See the manual or contact IAL.

Item	Description
Driving system	Ball screw φ10mm, Rolling C10
Positioning repeatability	±0.05mm
Lost motion	-
Base	Dedicated aluminum extruded material (A6063SS-T5 Equivalent) Black alumite treatment
Linear guide	Linear motion infinite circulating type
Static allowable moment	Ma: 48N·m
	Mb: 69N·m
	Mc: 97N·m
Dynamic allowable moment (Note 1)	Ma: 11N·m
	Mb: 16N·m
	Mc: 23N·m
Ambient operation temperature/humidity	0~40°C, 85%RH or less (Non-condensing)
Degree of protection	IP20
Vibration & shock resistance	4.9m/s ² 100Hz or less
Overseas standards	CE marking, RoHS (Restriction of Hazardous Substances)
Motor type	Stepper motor
Encoder type	Incremental / battery-less absolute
Number of encoder pulses	800 pulse/rev

(Note 1) Based on the standard rated operation life of 5,000 km. Operation life varies according to operating and mounting conditions. Confirm the operation life on P36.

Table of Payload by Speed/Acceleration

■ Setting for energy-saving disabled Unit for payload is kg. Operations on the blank locations are not possible.

Lead 20

Orientation	Acceleration (G)					
	Horizontal		Vertical			
Speed (mm/s)	0.3	0.5	0.7	1	0.3	0.5
0	15	10	8	7	1	1
160	15	10	8	7	1	1
320	12	10	8	6	1	1
480	12	9	8	6	1	1
640	12	8	6	5	1	1
800	10	6.5	4.5	3	1	1

Lead 12

Orientation	Acceleration (G)					
	Horizontal		Vertical			
Speed (mm/s)	0.3	0.5	0.7	1	0.3	0.5
0	26	18	16	14	2.5	2.5
80	26	18	16	14	2.5	2.5
200	26	18	16	14	2.5	2.5
320	26	18	14	12	2.5	2.5
440	26	18	12	10	2.5	2.5
560	20	12	8	7	2.5	2.5
700	15	9	5	4	2	1

Lead 6

Orientation	Acceleration (G)					
	Horizontal		Vertical			
Speed (mm/s)	0.3	0.5	0.7	1	0.3	0.5
0	32	26	24	20	6	6
40	32	26	24	20	6	6
100	32	26	24	20	6	6
160	32	26	24	20	6	6
220	32	26	24	20	6	6
280	32	26	24	15	6	5.5
340	32	20	18	12	5	4.5
400	22	12	11	8	3.5	3.5
450	15	8	6	4	2	2

Lead 3

Orientation	Acceleration (G)					
	Horizontal		Vertical			
Speed (mm/s)	0.3	0.5	0.7	1	0.3	0.5
0	40	35	35	35	12.5	12.5
50	40	35	35	35	12.5	12.5
80	40	35	35	30	12.5	12.5
110	40	35	35	30	12.5	12.5
140	40	35	35	28	12.5	12.5
170	40	32	32	24	12.5	12
200	35	28	23	20	10	9
225	28	20	16	12	6	

■ Setting for energy-saving enabled Operations on the blank locations not available

Lead 20

Orientation	Acceleration (G)		
	0.3	0.7	0.3
Speed (mm/s)			
0	8	5	0.75
160	8	5	0.75
320	8	5	0.75
480	8	4	0.75
640	6	3	0.75
800	4	1.5	0.75

Lead 12

Orientation	Acceleration (G)		
	0.3	0.7	0.3
Speed (mm/s)			
0	14	10	2
80	14	10	2
200	14	10	2
320	14	10	2
440	11	7	1.5
560	7	2.5	1
680	4	1	0.5

Lead 6

Orientation	Acceleration (G)		
	0.3	0.7	0.3
Speed (mm/s)			
0	20	14	5
40	20	14	5
100	20	14	5
160	20	14	5
220	16	14	4
280	13	7	2.5
340	10	1	1

Lead 3

Orientation	Acceleration (G)		
	0.3	0.7	0.3
Speed (mm/s)			
0	25	22	10
20	25	22	10
50	25	22	10
80	25	22	10
110	20	14	8
140	15	11	5
170	11	9	2

■ Direction of slider type moment

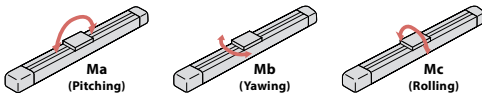

■ Stroke and maximum speed

Lead (mm)	Energy-saving mode	50-200 (mm) (per 50mm)	250 (mm)	300 (mm)	350 (mm)	400 (mm)
20	Disabled	800	727	566		
	Enabled	800	727	566		
12	Disabled	700	521	392	305	
	Enabled	680	521	392	305	
6	Disabled	450	371	265	199	155
	Enabled	340	265	199	155	
3	Disabled	225	188	134	100	78
	Enabled	170	134	100	78	

(Unit is mm/s)

■ Correlation between push force and current limit value

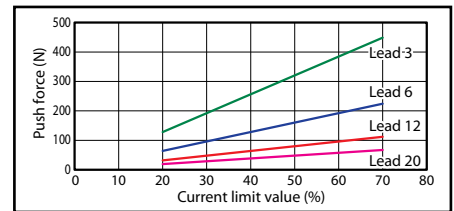

■ Dimensions

(Note) When the slider is returning to its home position, please be careful of interference from surrounding objects, as it will travel until it reaches the M.E.

CAD drawings can be downloaded from our website.
www.intelligentactuator.com

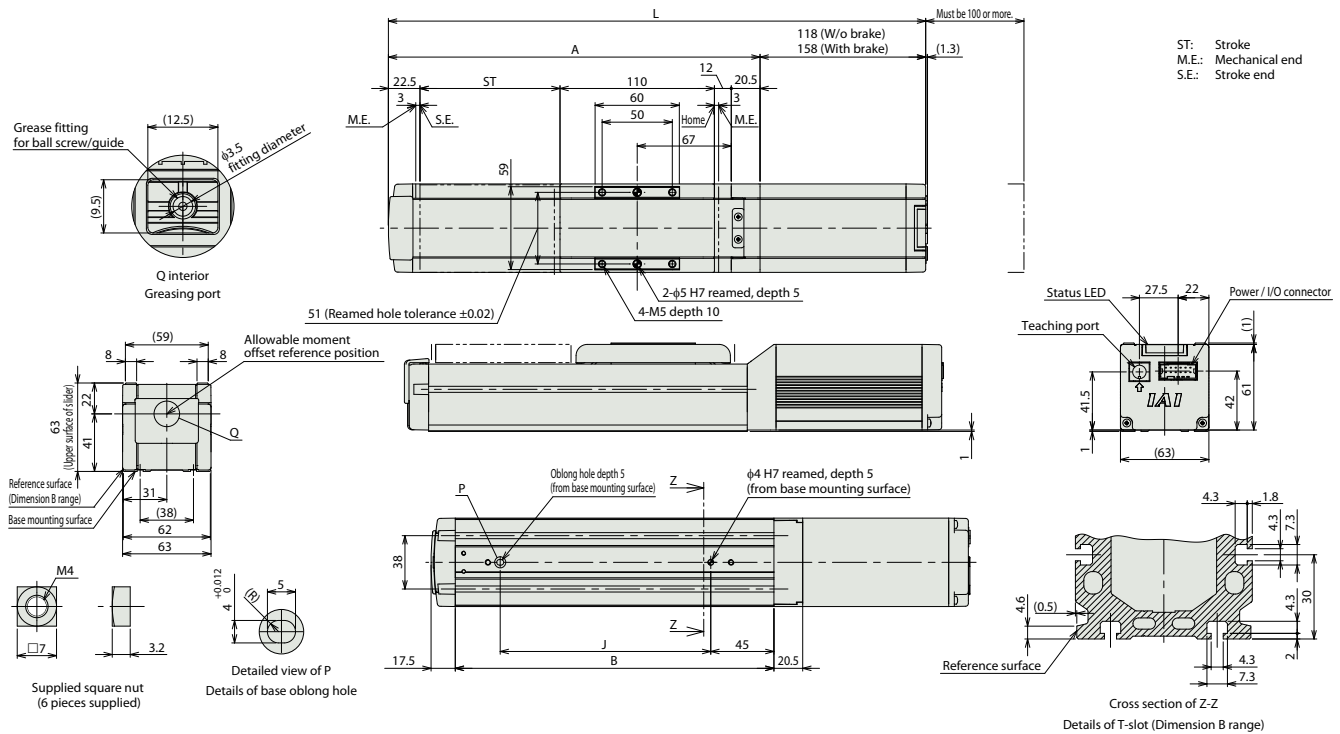

■ Dimensions by stroke

Stroke	50	100	150	200	250	300	350	400
L	W/o Brake	333	383	433	483	533	583	633
	With Brake	373	423	473	523	573	623	673
A	215	265	315	365	415	465	515	565
B	177	227	277	327	377	427	477	527
J	100	150	200	250	300	350	400	450

■ Mass by stroke

Stroke	Weight (kg)							
	50	100	150	200	250	300	350	400
W/o Brake	1.8	2.0	2.2	2.4	2.6	2.8	3.0	3.2
	With Brake	2.0	2.2	2.4	2.6	2.8	3.0	3.2

■ Applicable controller

(Note) The EC series is equipped with a built-in controller. Please refer to P116 for details.

EC-S7

Simple dust-proof
Coupled Motor
Body width 70 mm
24v Stepper motor

Model Specification Items

EC — **S7** [] — [] — [] — []

Series — Type — Lead — Stroke — Cable Length — Options

Lead	Stroke	Cable Length	Options
S 24mm	50 ↓ 500	0 With terminal block type connector ↓ 1 1m ↓ 10 10m	Refer to the option price list below
H 16mm	50mm ↓ 500mm (per 50mm)		
M 8mm			
L 4mm			

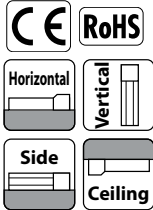

- (1) The actuator specifications display the payload's maximum value, but it will vary depending on the acceleration and speed. Please refer to "Table of Payload by Speed/Acceleration" for more details.
- (2) When performing a push-motion operation, please refer to the "Correlation between push force and current limit value." Push force is only a guide. Please refer to P115 for details.
- (3) Depending on the ambient operating temperature, duty control is necessary. Please refer to P109 for details.
- (4) Special attention needs to be paid to the mounting orientation. Please refer to P33 for details.
- (5) Reference value of the overhang load length is under 280mm in the Ma, Mb and Mc directions. Please refer to the illustration on P35 for the overhang load length.

Options

Type	Option code	Reference page
Brake	B	See P.101
Foot bracket	FT	See P.103
Non-motor end specification	NM	See P.108
PNP specification	PN	See P.108
Split motor and controller power supply specification	TMD2	See P.109
Battery-less Absolute Encoder specification	WA	See P.109
Wireless communication specification	WL	See P.109
Wireless axis-operation specification	WL2	See P.109

Stroke

Stroke (mm)	EC-S7	Stroke (mm)	EC-S7
50	○	300	○
100	○	350	○
150	○	400	○
200	○	450	○
250	○	500	○

Cable Length

Cable code	Cable length
0	No cable (with connector)
1 ~ 3	1 ~ 3m
4 ~ 5	4 ~ 5m
6 ~ 10	6 ~ 10m

(Note) Robot cables.

Main specifications

Item		Description				
Lead	Ball screw lead (mm)	24	16	8	4	
Horizontal	Payload	Max. payload (kg) (energy-saving disabled)	37	46	51	51
		Max. payload (kg) (energy-saving enabled)	18	35	40	40
	Speed/acceleration/deceleration	Max. speed (mm/s)	860	700	420	210
		Min. speed (mm/s)	30	20	10	5
Vertical	Payload	Max. payload (kg) (energy-saving disabled)	3	8	16	19
		Max. payload (kg) (energy-saving enabled)	2	5	10	15
	Speed/acceleration/deceleration	Max. speed (mm/s)	860	700	420	175
		Min. speed (mm/s)	30	20	10	5
Push force	Rated acceleration/deceleration (G)	0.3	0.3	0.3	0.3	
	Max. acceleration/deceleration (G)	1	1	1	1	
Brake	Max. payload (kg) (energy-saving disabled)	3	8	16	19	
	Max. payload (kg) (energy-saving enabled)	2	5	10	15	
Stroke	Max. speed (mm/s)	860	700	420	175	
	Min. speed (mm/s)	30	20	10	5	
Push force	Rated acceleration/deceleration (G)	0.3	0.3	0.3	0.3	
	Max. acceleration/deceleration (G)	0.5	0.5	0.5	0.5	
Brake	Pushing max. thrust force (N)*	139	209	418	836	
	Pushing max. speed (mm/s)	20	20	20	20	
Stroke	Brake holding specification	Non-excitation actuating solenoid brake				
	Brake holding force (kgf)	3	8	16	19	
Stroke	Min. stroke (mm)	50	50	50	50	
	Max. stroke (mm)	500	500	500	500	
	Stroke pitch (mm)	50	50	50	50	

* Speed limitation applies to push motion. See the manual or contact IAI.

Item	Description
Driving system	Ball screw φ12mm, Rolling C10
Positioning repeatability	±0.05mm
Lost motion	-
Base	Dedicated aluminum extruded material (A6063S5-T5 Equivalent) Black alumite treatment
Linear guide	Linear motion infinite circulating type
Static allowable moment	Ma: 79N·m
	Mb: 114N·m
	Mc: 157N·m
Dynamic allowable moment (Note 1)	Ma: 17N·m
	Mb: 25N·m
	Mc: 34N·m
Ambient operation temperature/humidity	0~40°C, 85%RH or less (Non-condensing)
Degree of protection	IP20
Vibration & shock resistance	4.9m/s ² 100Hz or less
Overseas standards	CE marking, RoHS (Restriction of Hazardous Substances)
Motor type	Stepper motor
Encoder type	Incremental / battery-less absolute
Number of encoder pulses	800 pulse/rev

(Note 1) Based on the standard rated operation life of 5,000 km. Operation life varies according to operating and mounting conditions. Confirm the operation life on P36.

Table of Payload by Speed/Acceleration

■ Setting for energy-saving disabled Unit for payload is kg. Operations on the blank locations are not possible.

Lead 24

Orientation	Horizontal					Vertical				
	Acceleration (G)					Acceleration (G)				
Speed (mm/s)	0.3	0.5	0.7	1	0.3	0.5	0.7	1	0.3	0.5
0	37	22	16	14	3	3				
200	37	22	16	14	3	3				
420	34	20	16	14	3	3				
640	20	15	10	9	3	3				
860	12	10	7	4	3	2.5				

Lead 16

Orientation	Horizontal					Vertical				
	Acceleration (G)					Acceleration (G)				
Speed (mm/s)	0.3	0.5	0.7	1	0.3	0.5	0.7	1	0.3	0.5
0	46	35	28	27	8	8				
140	46	35	28	27	8	8				
280	46	35	25	24	8	8				
420	34	25	15	10	5	4.5				
560	20	15	10	6	4	3				
700	15	10	5	3	3	2				

Lead 8

Posture	Horizontal					Vertical				
	Acceleration (G)					Acceleration (G)				
Speed (mm/s)	0.3	0.5	0.7	1	0.3	0.5	0.7	1	0.3	0.5
0	51	45	40	40	16	16				
70	51	45	40	40	16	16				
140	51	40	38	35	16	16				
210	51	35	30	24	10	9.5				
280	40	28	20	15	8	7				
350	30	9	4		5	4				
420	7				2					

Lead 4

Orientation	Horizontal					Vertical				
	Acceleration (G)					Acceleration (G)				
Speed (mm/s)	0.3	0.5	0.7	1	0.3	0.5	0.7	1	0.3	0.5
0	51	45	40	40	19	19				
35	51	45	40	40	19	19				
70	51	45	40	40	19	19				
105	51	45	40	35	19	19				
140	45	35	30	25	14	12				
175	30	18			9	7.5				
210	6									

■ Setting for energy-saving enabled Unit for payload is kg.

Lead 24

Orientation	Horizontal			Vertical
	Acceleration (G)			
Speed (mm/s)	0.3	0.7	0.3	
0	18	10	2	
200	18	10	2	
420	18	10	2	
640	10	2	1	
800	5	0.5	0.5	

Lead 16

Orientation	Horizontal			Vertical
	Acceleration (G)			
Speed (mm/s)	0.3	0.7	0.3	
0	35	20	5	
140	35	20	5	
280	25	12	3	
420	15	6	1.5	
560	7	0.5	0.5	

Lead 8

Orientation	Horizontal			Vertical
	Acceleration (G)			
Speed (mm/s)	0.3	0.7	0.3	
0	40	25	10	
70	40	25	10	
140	40	25	7	
210	25	14	4	
280	10	1	1.5	

Lead 4

Orientation	Horizontal			Vertical
	Acceleration (G)			
Speed (mm/s)	0.3	0.7	0.3	
0	40	30	15	
35	40	30	15	
70	40	30	15	
105	40	30	8	
140	15	6	2	

■ Direction of slider type moment

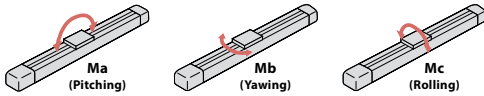

Stroke and maximum speed						
Lead (mm)	Energy-saving mode	50-300 (mm) (per 50mm)	350 (mm)	400 (mm)	450 (mm)	500 (mm)
24	Disabled	860	774	619	506	
	Enabled	800	774	619	506	
16	Disabled	700	631	492	395	323
	Enabled	560	492	395	323	
8	Disabled	420	322	251	200	164
	Enabled	280	251	200	164	
4	Disabled	210<175>	163	126	101	83
	Enabled	140	126	101	83	

Figures in <> represent vertical operations. (Unit is mm/s)

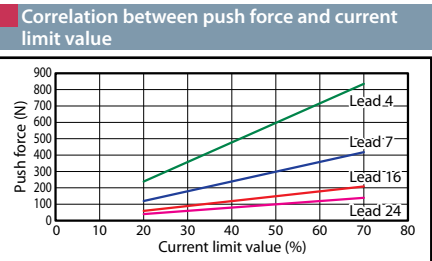

Dimensions

(Note) When the slider is returning to its home position, please be careful of interference from surrounding objects, as it will travel until it reaches the M.E.

CAD drawings can be downloaded from our website.

www.intelligentactuator.com

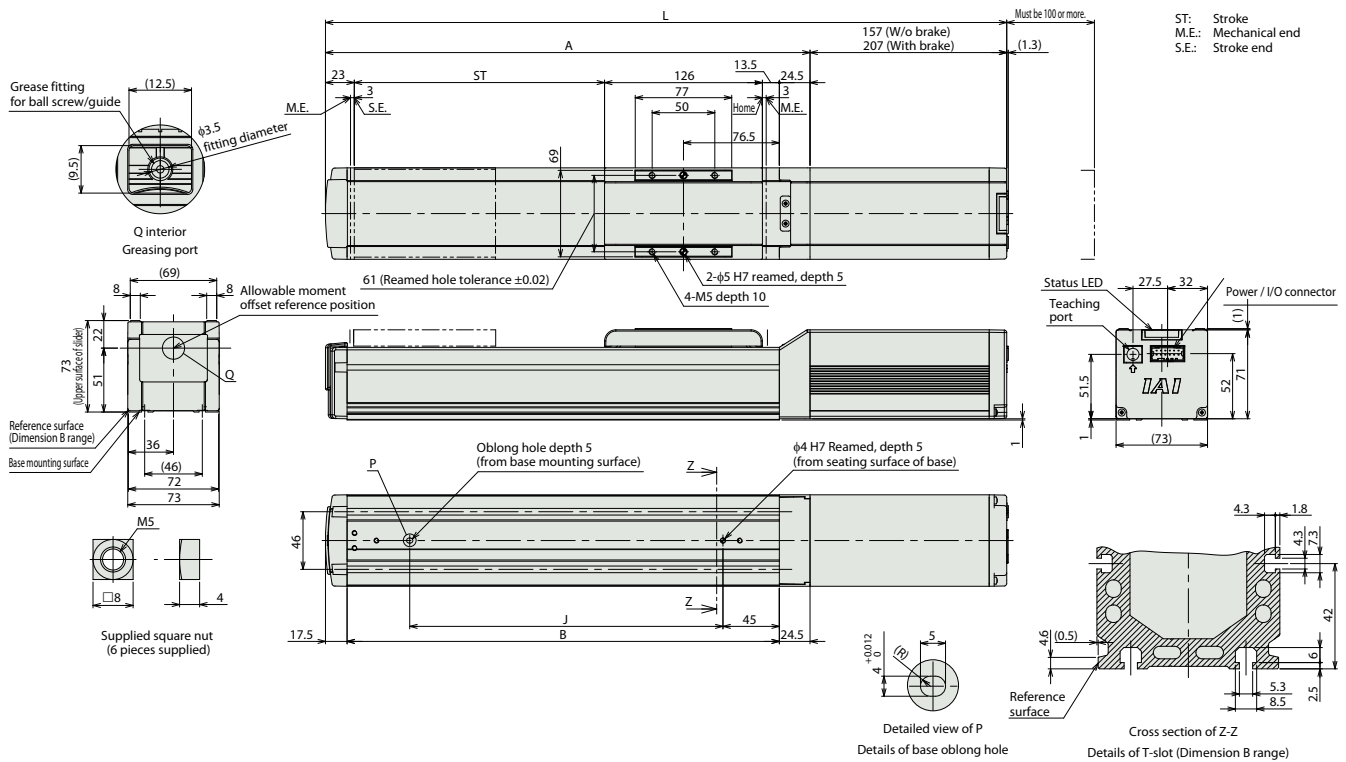

■ Dimensions by stroke

Stroke	50	100	150	200	250	300	350	400	450	500
	L	394	444	494	544	594	644	694	744	794
W/o Brake	444	494	544	594	644	694	744	794	844	894
With Brake	237	287	337	387	437	487	537	587	637	687
A	195	245	295	345	395	445	495	545	595	645
B	100	150	200	250	300	350	400	450	500	550
J										

■ Mass by stroke

Stroke	50	100	150	200	250	300	350	400	450	500
	Weight (kg)	3.4	3.6	3.9	4.2	4.4	4.7	5.0	5.2	5.5
W/o Brake	3.8	4.1	4.4	4.6	4.9	5.2	5.4	5.7	6.0	6.2
With Brake										

Applicable controller

(Note) The EC series is equipped with a built-in controller. Please refer to P111 for details.

EC-S6□AH

High Rigidity

Simple dust-proof

Coupled Motor

Body width 63 mm

24V Stepper motor

Model Specification Items

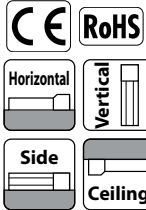
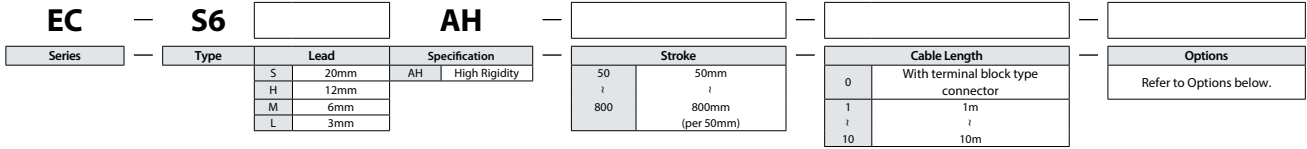

- (1) The actuator specifications display the payload's maximum value, but it will vary depending on the acceleration and speed. Please refer to "Table of Payload by Speed/Acceleration" for more details.
- (2) When performing a push-motion operation, please refer to the "Correlation between push force and current limit value." Push force is only a guide. Please refer to P109 for details.
- (3) Depending on the ambient operating temperature, duty control is necessary. Please refer to P115 for details.
- (4) Special attention needs to be paid to the mounting orientation. Please refer to P33 for details.
- (5) Reference value of the overhang load length is under 300mm in the Ma, Mb and Mc directions. Please refer to the illustration on P35 for the overhang load length.
- (6) The center of gravity of the attached object should be less than 1/2 of the overhand distance. Even when the overhang distance and load moment are within the allowable range, the operating conditions should be moderated if some abnormal vibration or noise is observed.

Stroke			
Stroke (mm)	EC-S6□AH	Stroke (mm)	EC-S6□AH
50	○	450	○
100	○	500	○
150	○	550	○
200	○	600	○
250	○	650	○
300	○	700	○
350	○	750	○
400	○	800	○

Options			
Name	Option code	Reference page	
Brake	B	See P.101	
Non-motor end specification	NM	See P.108	
PNP specification	PN	See P.108	
Split motor and controller power supply specification	TMD2	See P.109	
Battery-less Absolute Encoder specification	WA	See P.109	
Wireless communication specification	WL	See P.109	
Wireless axis-operation specification	WL2	See P.109	

Cable Length	
Cable code	Cable length
0	No cable (with connector)
1 ~ 3	1 ~ 3m
4 ~ 5	4 ~ 5m
6 ~ 10	6 ~ 10m

(Note) Robot cables.

Main specifications						
Item		Description				
Lead	Ball screw lead (mm)	20	12	6	3	
	Payload	Max. payload (kg) (energy-saving disabled)	15	26	32	40
		Max. payload (kg) (energy-saving enabled)	8	14	20	25
Horizontal	Speed/acceleration/deceleration	Max. speed (mm/s)	1440	900	450	225
		Min. speed (mm/s)	25	15	8	4
		Rated acceleration/deceleration (G)	0.3	0.3	0.3	0.3
		Max. acceleration/deceleration (G)	1	1	1	1
		Max. payload (kg) (energy-saving disabled)	1	2.5	6	16
Vertical	Speed/acceleration/deceleration	Max. speed (mm/s)	1280	900	450	225
		Min. speed (mm/s)	25	15	8	4
		Rated acceleration/deceleration (G)	0.3	0.3	0.3	0.3
		Max. acceleration/deceleration (G)	0.5	0.5	0.5	0.5
		Pushing max. thrust force (N)*	67	112	224	449
Push force	Pushing max. speed (mm/s)	20	20	20	20	
	Brake	Brake holding specification		Non-excitation actuating solenoid brake		
Brake holding force (kgf)		1	2.5	6	16	
Stroke	Min. stroke (mm)	50	50	50	50	
	Max. stroke (mm)	800	800	800	800	
	Stroke pitch (mm)	50	50	50	50	

* Speed limitation applies to push motion. See the manual or contact IAI.

Item		Description
Driving system	Ball screw φ10mm, Rolling C10	
Positioning repeatability	±0.05mm	
Lost motion	-	
Base	Dedicated aluminum extruded material (A6063S5-T6 Equivalent) Black alumite treatment	
Linear guide	Linear motion infinite circulating type	
Static allowable moment	Ma: 48N·m	
	Mb: 69N·m	
	Mc: 103N·m	
Dynamic allowable moment (Note 1)	Ma: 33N·m	
	Mb: 40N·m	
	Mc: 55N·m	
Ambient operation temperature/humidity	0~40°C, 85%RH or less (Non-condensing)	
Degree of protection	IP20	
Vibration & shock resistance	4.9m/s ² 100Hz or less	
Overseas standards	CE marking, RoHS (Restriction of Hazardous Substances)	
Motor type	Stepper motor	
Encoder type	Incremental / battery-less absolute	
Number of encoder pulses	800 pulse/rev	

(Note 1) Based on the standard rated operation life of 5,000 km. Operation life varies according to operating and mounting conditions. Confirm the operation life on P36.

Table of Payload by Speed/Acceleration																								
■ Setting for energy-saving disabled Unit for payload is kg. Operations on the blank locations are not possible.																								
Lead 20					Lead 12					Lead 6					Lead 3									
Orientation	Horizontal				Vertical	Orientation	Horizontal				Vertical	Orientation	Horizontal				Vertical							
	Acceleration (G)						Acceleration (G)						Acceleration (G)					Acceleration (G)						
Speed (mm/s)	0.3	0.5	0.7	1	0.3	0.5	0.7	1	0.3	0.5	0.3	0.5	0.7	1	0.3	0.5								
0	15	10	8	7	1	1	1	1	1	1	32	26	24	20	6	6	40	35	35	35	16	16		
160	15	10	8	7	1	1	1	1	1	1	40	32	26	24	20	6	6	50	40	35	35	16	16	
320	12	10	8	6	1	1	1	1	1	1	100	32	26	24	20	6	6	80	40	35	35	30	16	16
480	12	9	8	6	1	1	1	1	1	1	160	32	26	24	20	6	6	110	40	35	35	30	16	16
640	12	8	6	5	1	1	1	1	1	1	220	32	26	24	20	6	6	140	40	35	35	28	15	15
800	10	6.5	4.5	3	1	1	1	1	1	1	280	32	26	24	15	6	5.5	170	40	32	32	24	12.5	12
960	8	5	3.5	1.5	1	1	1	1	1	1	340	32	20	18	12	5	4.5	200	35	28	23	20	10	9
1120	5	3	2	1	0.5	0.5					400	22	12	11	8	3.5	3.5	225	28	20	16	12	6	
1280	1	1	0.5								450	15	8	6	4	2	2							
1440	1	0.5																						

■ Setting for energy-saving enabled Unit for payload is kg.

Lead 20

Orientation	Horizontal			Vertical
	Acceleration (G)			
Speed (mm/s)	0.3	0.7	0.3	
0	8	5	0.75	
160	8	5	0.75	
320	8	5	0.75	
480	8	4	0.75	
640	6	3	0.75	
800	4	1.5	0.75	

Lead 12

Orientation	Horizontal			Vertical
	Acceleration (G)			
Speed (mm/s)	0.3	0.7	0.3	
0	14	10	2	
80	14	10	2	
200	14	10	2	
320	14	10	2	
440	11	7	1.5	
560	7	2.5	1	
680	4	1	0.5	

Lead 6

Orientation	Horizontal			Vertical
	Acceleration (G)			
Speed (mm/s)	0.3	0.7	0.3	
0	20	14	5	
40	20	14	5	
100	20	14	5	
160	20	14	5	
220	16	14	4	
280	13	7	2.5	
340	10	1	1	

Lead 3

Orientation	Horizontal			Vertical
	Acceleration (G)			
Speed (mm/s)	0.3	0.7	0.3	
0	25	22	10	
20	25	22	10	
50	25	22	10	
80	25	22	10	
110	20	14	8	
140	15	11	5	
170	11	9	2	

■ Direction of slider type moment

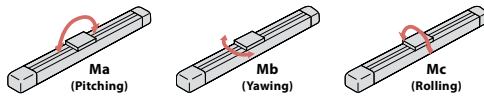

Stroke and maximum speed

Lead (mm)	Energy-saving mode	Stroke (mm)													
		50-300 (per 50mm)	450	500	550	600	650	700	750	800	850	900	950	1000	
20	Disabled	1440	<1280>												
	Enabled	800													
12	Disabled	900	845	705	585	515	445	390	345	305					
	Enabled	680													
6	Disabled	450	415	350	295	255	220	190	170	140					
	Enabled	340													
3	Disabled	225	205	170	145	125	110	95	85	70					
	Enabled	170													

(Note) Figures in < > represent vertical operations. (Unit is mm/s)

Correlation between push force and current limit value

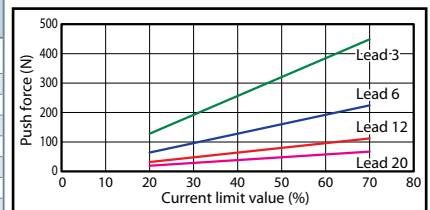

Dimensions

(Note) When the slider is returning to its home position, please be careful of interference from surrounding objects, as it will travel until it reaches the M.E.

CAD drawings can be downloaded from our website.
www.intelligentactuator.com

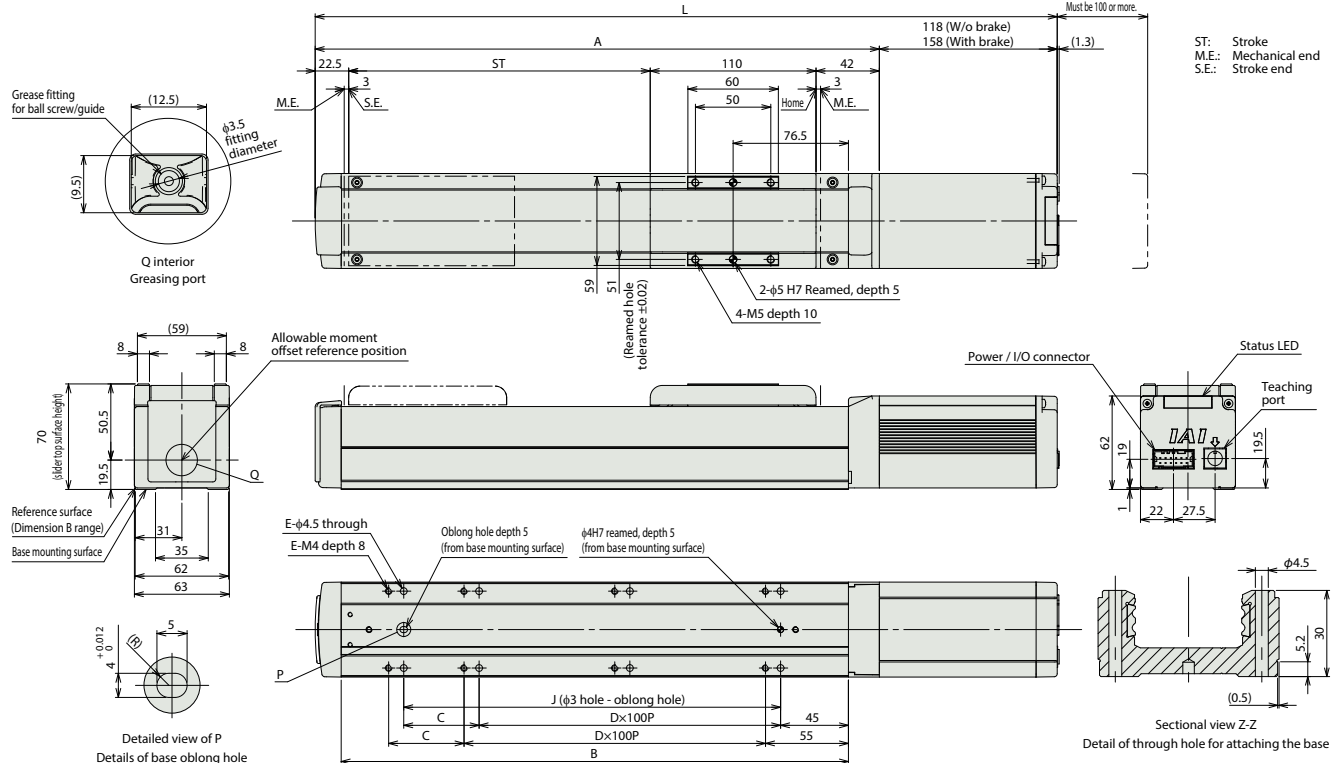

■ Dimensions by stroke

Stroke	50	100	150	200	250	300	350	400	450	500	550	600	650	700	750	800
	L	342.5	392.5	442.5	492.5	542.5	592.5	642.5	692.5	742.5	792.5	842.5	892.5	942.5	992.5	1042.5
W/o Brake	382.5	432.5	482.5	532.5	582.5	632.5	682.5	732.5	782.5	832.5	882.5	932.5	982.5	1032.5	1082.5	1132.5
With Brake	224.5	274.5	324.5	374.5	424.5	474.5	524.5	574.5	624.5	674.5	724.5	774.5	824.5	874.5	924.5	974.5
A	186.5	236.5	286.5	336.5	386.5	436.5	486.5	536.5	586.5	636.5	686.5	736.5	786.5	836.5	886.5	936.5
B	0	50	0	50	0	50	0	50	0	50	0	50	0	50	0	50
C	1	1	2	2	3	3	4	4	5	5	6	6	7	7	8	8
D	4	6	6	8	8	10	10	12	12	14	14	16	16	18	18	20
E	100	150	200	250	300	350	400	450	500	550	600	650	700	750	800	850
J																

■ Mass by stroke

Stroke	50	100	150	200	250	300	350	400	450	500	550	600	650	700	750	800
	Weight (kg)	2	2.2	2.4	2.6	2.9	3.1	3.3	3.5	3.8	4	4.2	4.4	4.7	4.9	5.1
With Brake	2.3	2.5	2.7	2.9	3.2	3.4	3.6	3.8	4.1	4.3	4.5	4.7	5	5.2	5.4	5.6

■ Applicable controller

(Note) The EC series is equipped with a built-in controller. Please refer to P116 for details.

EC-S7□AH

High Rigidity Simple dust-proof Coupled Motor Body width 75 mm 24V Stepper motor

■ Model Specification Items

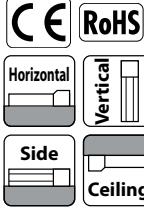
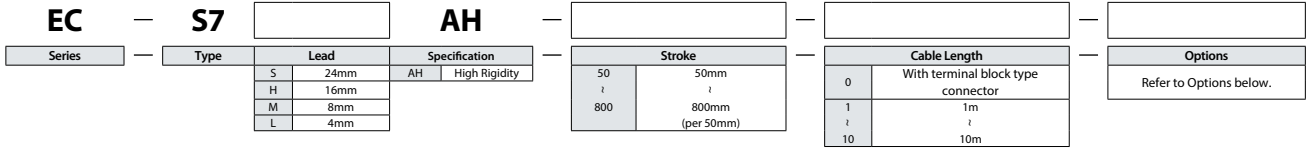

- POINT Selection Notes**
- (1) The actuator specifications display the payload's maximum value, but when energy-saving is activated, the specifications will change. Please refer to "Table of Payload by Speed/Acceleration" for more details.
 - (2) When performing a push-motion operation, please refer to the "Correlation between push force and current limit value." Push force is only a guide. Please refer to P109 for details.
 - (3) Depending on the ambient operating temperature, duty control is necessary. Please refer to P115 for details.
 - (4) Special attention needs to be paid to the mounting orientation. Please refer to P33 for details.
 - (5) Reference value of the overhang load length is under 300mm in the Ma, Mb and Mc directions. Please refer to the illustration on P35 for the overhang load length.
 - (6) The center of gravity of the attached object should be less than 1/2 of the overhang distance. Even when the overhang distance and load moment are within the allowable range, the operating conditions should be moderated if some abnormal vibration or noise is observed.

Stroke

Stroke (mm)	EC-S7□AH	Stroke (mm)	EC-S7□AH
50	○	450	○
100	○	500	○
150	○	550	○
200	○	600	○
250	○	650	○
300	○	700	○
350	○	750	○
400	○	800	○

Options

Name	Option code	Reference page
Brake	B	See P.101
Non-motor end specification	NM	See P.108
PNP specification	PN	See P.108
Split motor and controller power supply specification	TMD2	See P.109
Battery-less Absolute Encoder specification	WA	See P.109
Wireless communication specification	WL	See P.109
Wireless axis-operation specification	WL2	See P.109

Cable Length

Cable code	Cable length
0	No cable (with connector)
1 ~ 3	1 ~ 3m
4 ~ 5	4 ~ 5m
6 ~ 10	6 ~ 10m

(Note) Robot cables.

Main specifications

Item	Description
Lead	Ball screw lead (mm) 24 16 8 4
Horizontal	Max. payload (kg) (energy-saving disabled) 37 46 51 51
	Max. payload (kg) (energy-saving enabled) 18 35 40 40
	Max. speed (mm/s) 1230 980 420 210
Vertical	Max. speed (mm/s) 30 20 10 5
	Rated acceleration/deceleration (G) 0.3 0.3 0.3 0.3
	Max. acceleration/deceleration (G) 1 1 1 1
Push force	Max. payload (kg) (energy-saving disabled) 3 8 16 25
	Max. payload (kg) (energy-saving enabled) 2 5 10 15
	Max. speed (mm/s) 1230 840 420 175
Speed/acceleration/deceleration	Min. speed (mm/s) 30 20 10 5
	Rated acceleration/deceleration (G) 0.3 0.3 0.3 0.3
	Max. acceleration/deceleration (G) 0.5 0.5 0.5 0.5
Brake	Pushing max. thrust force (N)* 139 209 418 836
	Pushing max. speed (mm/s) 20 20 20 20
Stroke	Non-excitation actuating solenoid brake
	Brake holding force (kgf) 3 8 16 25
Brake	Min. stroke (mm) 50 50 50 50
	Max. stroke (mm) 800 800 800 800
	Stroke pitch (mm) 50 50 50 50

* Speed limitation applies to push motion. See the manual or contact IAI.

Item	Description
Driving system	Ball screw φ12mm, Rolling C10
Positioning repeatability	±0.05mm
Lost motion	-
Base	Dedicated aluminum extruded material (A6063S5-T6 Equivalent) Black alumite treatment
Linear guide	Linear motion infinite circulating type Ma: 115N·m Mb: 115N·m Mc: 229N·m Ma: 75N·m Mb: 90N·m Mc: 134N·m
Static allowable moment	
Dynamic allowable moment (Note 1)	
Ambient operation temperature/humidity	0~40°C, 85%RH or less (Non-condensing)
Degree of protection	IP20
Vibration & shock resistance	4.9m/s ² 100Hz or less
Overseas standards	CE marking, RoHS (Restriction of Hazardous Substances)
Motor type	Stepper motor
Encoder type	Incremental / battery-less absolute
Number of encoder pulses	800 pulse/rev

(Note 1) Based on the standard rated operation life of 5,000 km. Operation life varies according to operating and mounting conditions. Confirm the operation life on P36.

Table of Payload by Speed/Acceleration

■ Setting for energy-saving disabled Unit for payload is kg. Operations on the blank locations are not possible.

Lead 24

Orientation	Acceleration (G)					
	Horizontal		Vertical			
Speed (mm/s)	0.3	0.5	0.7	1	0.3	0.5
0	37	22	16	14	3	3
200	37	22	16	14	3	3
420	34	20	16	14	3	3
640	20	15	10	9	3	3
860	12	10	7	4	3	2.5
1080	8	4.5	3	1.5	1	0.5
1230	3	1.5	1	0.5	0.5	

Lead 16

Orientation	Acceleration (G)					
	Horizontal		Vertical			
Speed (mm/s)	0.3	0.5	0.7	1	0.3	0.5
0	46	35	28	27	8	8
140	46	35	28	27	8	8
280	46	35	25	24	8	8
420	34	25	15	10	5	4.5
560	20	15	10	6	4	3
700	15	10	5	3	3	2
840	7	4	2		0.5	
980	4					

Lead 8

Orientation	Acceleration (G)					
	Horizontal		Vertical			
Speed (mm/s)	0.3	0.5	0.7	1	0.3	0.5
0	51	45	40	40	16	16
70	51	45	40	40	16	16
140	51	40	38	35	16	16
210	51	35	30	24	10	9.5
280	40	28	20	15	8	7
350	30	9	4		5	4
420	7				2	

Lead 4

Orientation	Acceleration (G)					
	Horizontal		Vertical			
Speed (mm/s)	0.3	0.5	0.7	1	0.3	0.5
0	51	45	40	40	25	25
35	51	45	40	40	25	25
70	51	45	40	40	25	25
105	51	45	40	35	20	19
140	45	35	30	25	14	12
175	30	18			9	7.5
210	6					

Direction of slider type moment

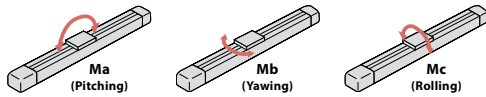

Stroke and maximum speed

Lead (mm)	Energy-saving mode	50-500 (per 50mm)	550 (mm)	600 (mm)	650 (mm)	700 (mm)	750 (mm)	800 (mm)	
24	Disabled	1230		1080	950	840	750	750	
	Enabled	800							750
16	Disabled	980 <840>	955 <840>	820	715	625	555	495	
	Enabled	560						555	495
8	Disabled	420		405	350	310	275	245	
	Enabled	280						275	245
4	Disabled	210 <175>	195 <175>	175	150	135	120	120	
	Enabled	140							135

(Note) Figures in < > represent vertical operations. (Unit is mm/s)

Correlation between push force and current limit value

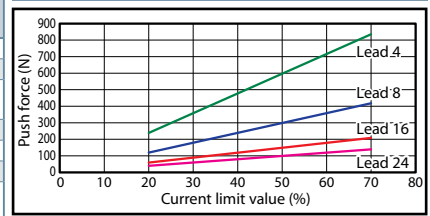

Setting for energy-saving enabled Unit for payload is kg.

Lead 24

Orientation	Speed (mm/s)	Acceleration (G)		
		Horizontal	Vertical	Vertical
		0.3	0.7	0.3
0	18	10	2	2
200	18	10	2	2
420	18	10	2	2
640	10	2	1	1
800	5	0.5	0.5	0.5

Lead 16

Orientation	Speed (mm/s)	Acceleration (G)		
		Horizontal	Vertical	Vertical
		0.3	0.7	0.3
0	35	20	5	5
140	35	20	5	5
280	25	12	3	3
420	15	6	1.5	1.5
560	7	0.5	0.5	0.5

Lead 8

Orientation	Speed (mm/s)	Acceleration (G)		
		Horizontal	Vertical	Vertical
		0.3	0.7	0.3
0	40	25	10	10
70	40	25	10	10
140	40	25	7	7
210	25	14	4	4
280	10	1	1.5	1.5

Lead 4

Orientation	Speed (mm/s)	Acceleration (G)		
		Horizontal	Vertical	Vertical
		0.3	0.7	0.3
0	40	30	15	15
35	40	30	15	15
70	40	30	15	15
105	40	30	8	8
140	15	6	2	2

Dimensions

(Note) When the slider is returning to its home position, please be careful of interference from surrounding objects, as it will travel until it reaches the M.E.

CAD drawings can be downloaded from our website. www.intelligentactuator.com

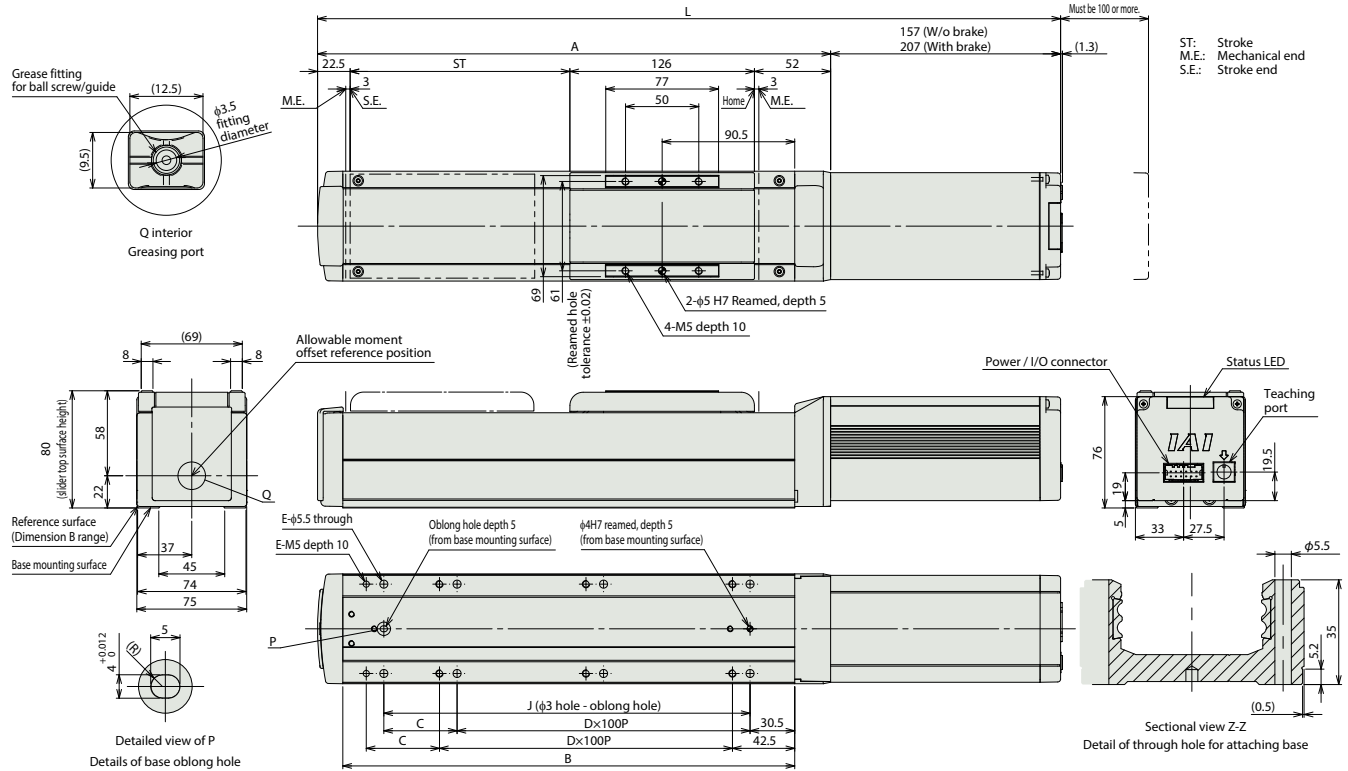

Dimensions by stroke

Stroke	50	100	150	200	250	300	350	400	450	500	550	600	650	700	750	800	
L	W/o Brake	407.5	457.5	507.5	557.5	607.5	657.5	707.5	757.5	807.5	857.5	907.5	957.5	1007.5	1057.5	1107.5	1157.5
	With Brake	457.5	507.5	557.5	607.5	657.5	707.5	757.5	807.5	857.5	907.5	957.5	1007.5	1057.5	1107.5	1157.5	1207.5
A	250.5	300.5	350.5	400.5	450.5	500.5	550.5	600.5	650.5	700.5	750.5	800.5	850.5	900.5	950.5	1000.5	
B	208.5	258.5	308.5	358.5	408.5	458.5	508.5	558.5	608.5	658.5	708.5	758.5	808.5	858.5	908.5	958.5	
C	50	0	50	0	50	0	50	0	50	0	50	0	50	0	50	0	
D	1	2	2	3	3	4	4	5	5	6	6	7	7	8	8	9	
E	6	6	8	8	10	10	12	12	14	14	16	16	18	18	20	20	
J	150	200	250	300	350	400	450	500	550	600	650	700	750	800	850	900	

Mass by stroke

Stroke	50	100	150	200	250	300	350	400	450	500	550	600	650	700	750	800	
Weight (kg)	W/o Brake	3.9	4.1	4.4	4.7	4.9	5.2	5.5	5.7	6	6.3	6.5	6.8	7.1	7.3	7.6	7.9
	With Brake	4.4	4.6	4.9	5.2	5.4	5.7	6	6.2	6.5	6.8	7	7.3	7.6	7.8	8.1	8.4

Applicable controller

(Note) The EC series is equipped with a built-in controller. Please refer to P116 for details.

EC-S6□R

Simple dust-proof

Side-mounted Motor

Body width 60 mm

24v Stepper motor

Model Specification Items

EC	—	S6	<input type="text"/>	R	—	<input type="text"/>	—	<input type="text"/>	—	<input type="text"/>
Series	—	Type	Lead	Specification	—	Stroke	—	Cable Length	—	Options
			S 20mm H 12mm M 6mm L 3mm	R Side-mounted motor		50 1 400	50mm 400mm (per 50mm)	0 1 1 10	Terminal type with connector 1m 1 10m	Refer to the price list below

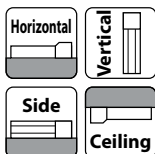

(Note) The above photo shows motor side-mounted to the left (ML).



- The actuator specifications display the payload's maximum value, but it will vary depending on the acceleration and speed. Please refer to "Table of Payload by Speed/Acceleration" for more details.
- When performing a push-motion operation, please refer to the "Correlation between push force and current limit value." Push force is only a guide. Please refer to P109 for cautions.
- Depending on the ambient operating temperature, duty control is necessary. Please refer to P115 for cautions.
- Special attention needs to be paid to the mounting orientation. Please refer to P33 for details.
- Reference value of the overhang load length is under 220mm in the Ma, Mb and Mc directions. Please refer to the illustration on P35 for the overhang load length.
- The center of gravity of the attached object should be less than 1/2 of the overhang distance. Even when the overhang distance and load moment are within the allowable range, the operating conditions should be moderated if some abnormal vibration or noise is observed.

Options

Name	Option code	Reference page
Brake	B	See P.101
Foot bracket	FT	See P.103
Motor side-mounted to the left (Note 1)	ML	See P.105
Motor side-mounted to the right (Note 1)	MR	See P.105
Non-motor end specification	NM	See P.108
PNP specification	PN	See P.108
Split motor and controller power supply specification	TMD2	See P.109
Battery-less absolute encoder	WA	See P.109
Wireless communication specification	WL	See P.109
Wireless axis-operation specification	WL2	See P.109

(Note 1) Make sure to enter a code in the option column of the model spec item.

Cable length price list (standard price)

Cable code	Cable length
0	No cable (connector supplied)
1 ~ 3	1 ~ 3m
4 ~ 5	4 ~ 5m
6 ~ 10	6 ~ 10m

(Note) Robot cables.

Stroke

Stroke (mm)	EC-S6□R	Stroke (mm)	EC-S6□R
50	<input type="radio"/>	250	<input type="radio"/>
100	<input type="radio"/>	300	<input type="radio"/>
150	<input type="radio"/>	350	<input type="radio"/>
200	<input type="radio"/>	400	<input type="radio"/>

Main specifications

Item		Description				
Lead	Ball screw lead (mm)	20	12	6	3	
Horizontal	Payload	Max. payload (kg) (energy-saving disabled)	15	26	32	40
		Max. payload (kg) (energy-saving enabled)	8	14	20	25
	Speed/acceleration/deceleration	Max. speed (mm/s)	800	700	450	225
		Min. speed (mm/s)	25	15	8	4
	Rated acceleration/deceleration (G)	0.3	0.3	0.3	0.3	
	Max. acceleration/deceleration (G)	1	1	1	1	
Vertical	Payload	Max. payload (kg) (energy-saving disabled)	1	2.5	6	12.5
		Max. payload (kg) (energy-saving enabled)	0.75	2	5	10
	Speed/acceleration/deceleration	Max. speed (mm/s)	800	700	400	225
		Min. speed (mm/s)	25	15	8	4
	Rated acceleration/deceleration (G)	0.3	0.3	0.3	0.3	
	Max. acceleration/deceleration (G)	0.5	0.5	0.5	0.5	
Push force	Max. thrust force when pushing (N)*	67	112	224	449	
	Max. speed when pushing (mm/s)	20	20	20	20	
Brake	Brake specification	Non-excitation actuating solenoid brake				
	Brake holding force (kgf)	1	2.5	6	12.5	
Stroke	Min. stroke (mm)	50	50	50	50	
	Max. stroke (mm)	400	400	400	400	
	Stroke pitch (mm)	50	50	50	50	

* Speed limitation applies to push motion. See the manual or contact IAI.

Item	Description
Driving system	Ball screw φ 10mm, Rolling C10
Positioning repeatability	±0.05mm
Lost motion	-
Base	Dedicated aluminum extruded material(A6063S5-T5 or equivalent) Black alumite treatment
Linear guide	Linear motion infinite circulating type
Static allowable moment	Ma: 48N·m
	Mb: 69N·m
	Mc: 97N·m
Dynamic allowable moment (Note 2)	Ma: 11N·m
	Mb: 16N·m
	Mc: 23N·m
Ambient operation temperature/humidity	0~40°C, RH 85% or less (Non-condensing)
Degree of protection	IP20
Vibration & shock resistance	4.9m/s ² 100Hz or less
Overseas standards	CE Marking, RoHS (Restriction of Hazardous Substances)
Motor type	Stepper motor
Encoder type	Incremental / battery-less absolute
Number of encoder pulses	800 pulse/rev

(Note 2) Based on the standard rated operation life of 5,000 km. Operation life varies depending on operating and mounting conditions. Confirm the operation life on P36.

Table of Payload by Speed and Acceleration

Energy-saving disabled The unit for payload is kg. Operations in the blank locations are not possible.

Lead 20

Orientation	Speed (mm/s)	Acceleration (G)					
		0.3	0.5	0.7	1	0.3	0.5
Horizontal	0	15	10	8	7	1	1
	160	15	10	8	7	1	1
	320	12	10	8	6	1	1
	480	12	9	8	6	1	1
	640	12	6.5	6	5	1	1
800	9	5	4	3	1	1	

Lead 12

Orientation	Speed (mm/s)	Acceleration (G)					
		0.3	0.5	0.7	1	0.3	0.5
Horizontal	0	26	18	16	14	2.5	2.5
	80	26	18	16	14	2.5	2.5
	200	26	18	16	14	2.5	2.5
	320	26	18	14	12	2.5	2.5
	440	26	18	12	9	2.5	2.5
Vertical	560	26	12	7	5	2.5	2.5
	700	18	5	3	4	1.5	1

Lead 6

Orientation	Speed (mm/s)	Acceleration (G)					
		0.3	0.5	0.7	1	0.3	0.5
Horizontal	0	32	26	24	20	6	6
	40	32	26	24	20	6	6
	100	32	26	24	20	6	6
	160	32	26	24	20	6	6
	220	32	26	24	20	6	6
Vertical	280	32	26	18	15	6	5.5
	340	25	14	12	9	4	3.5
	400	15	8	8	5	2.5	2
	450	10	5				

Lead 3

Orientation	Speed (mm/s)	Acceleration (G)					
		0.3	0.5	0.7	1	0.3	0.5
Horizontal	0	40	35	35	35	12.5	12.5
	50	40	35	35	35	12.5	12.5
	80	40	35	35	30	12.5	12.5
	110	40	35	35	30	12.5	12.5
	140	40	35	35	28	12.5	12.5
Vertical	170	40	32	32	24	9	8
	200	35	20	15	12	6	4
	225	18	10				

■ Energy-saving enabled The unit for payload is kg. Operations in the blank locations are not possible.

Lead 20

Orientation	Horizontal			Vertical
	Acceleration (G)			
Speed (mm/s)	0.3	0.7	0.3	
0	8	5	0.75	
160	8	5	0.75	
320	8	5	0.75	
480	8	4	0.75	
640	6	3	0.75	
800	4	1.5	0.5	

Lead 12

Orientation	Horizontal			Vertical
	Acceleration (G)			
Speed (mm/s)	0.3	0.7	0.3	
0	14	10	2	
80	14	10	2	
200	14	10	2	
320	14	10	2	
440	11	7	1.5	
560	7	2.5	1	
680	2			

Lead 6

Orientation	Horizontal			Vertical
	Acceleration (G)			
Speed (mm/s)	0.3	0.7	0.3	
0	20	14	5	
40	20	14	5	
100	20	14	5	
160	20	14	5	
220	16	14	4	
280	13	7	2.5	
340	8	1	1	

Lead 3

Orientation	Horizontal			Vertical
	Acceleration (G)			
Speed (mm/s)	0.3	0.7	0.3	
0	25	22	10	
20	25	22	10	
50	25	22	10	
80	25	22	10	
110	20	14	8	
140	15	11	5	
170	11	5	2	

■ Direction of slider type moment

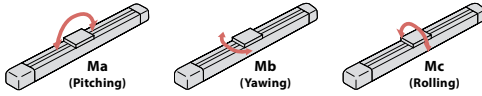

Stroke and maximum speed

Lead (mm)	Energy-saving mode	50-200 (per 50mm)	250 (mm)	300 (mm)	350 (mm)	400 (mm)
		20	Disabled	800	727	566
	Enabled	800	727	566		
12	Disabled	700	521	392	305	
	Enabled	680 <560>	521	392	305	
6	Disabled	450 <400>	371	265	199	155
	Enabled	340	265	199	155	
3	Disabled	225	188	134	100	78
	Enabled	170	134	100	78	

Correlation between push force and current limit value

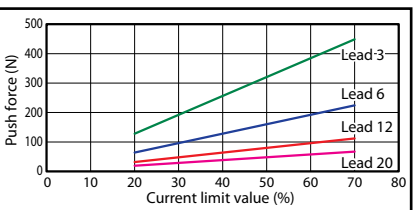

(Note) Figures in < > represent vertical operations.

(Unit is mm/s)

Dimensions

(Note) When the slider is returning to its home position, please be careful of interference from surrounding objects, as it will travel until it reaches the M.E.
 (Note) The drawing below represents motor side-mounted to the left (ML).

CAD drawings can be downloaded from our website.
www.intelligentactuator.com

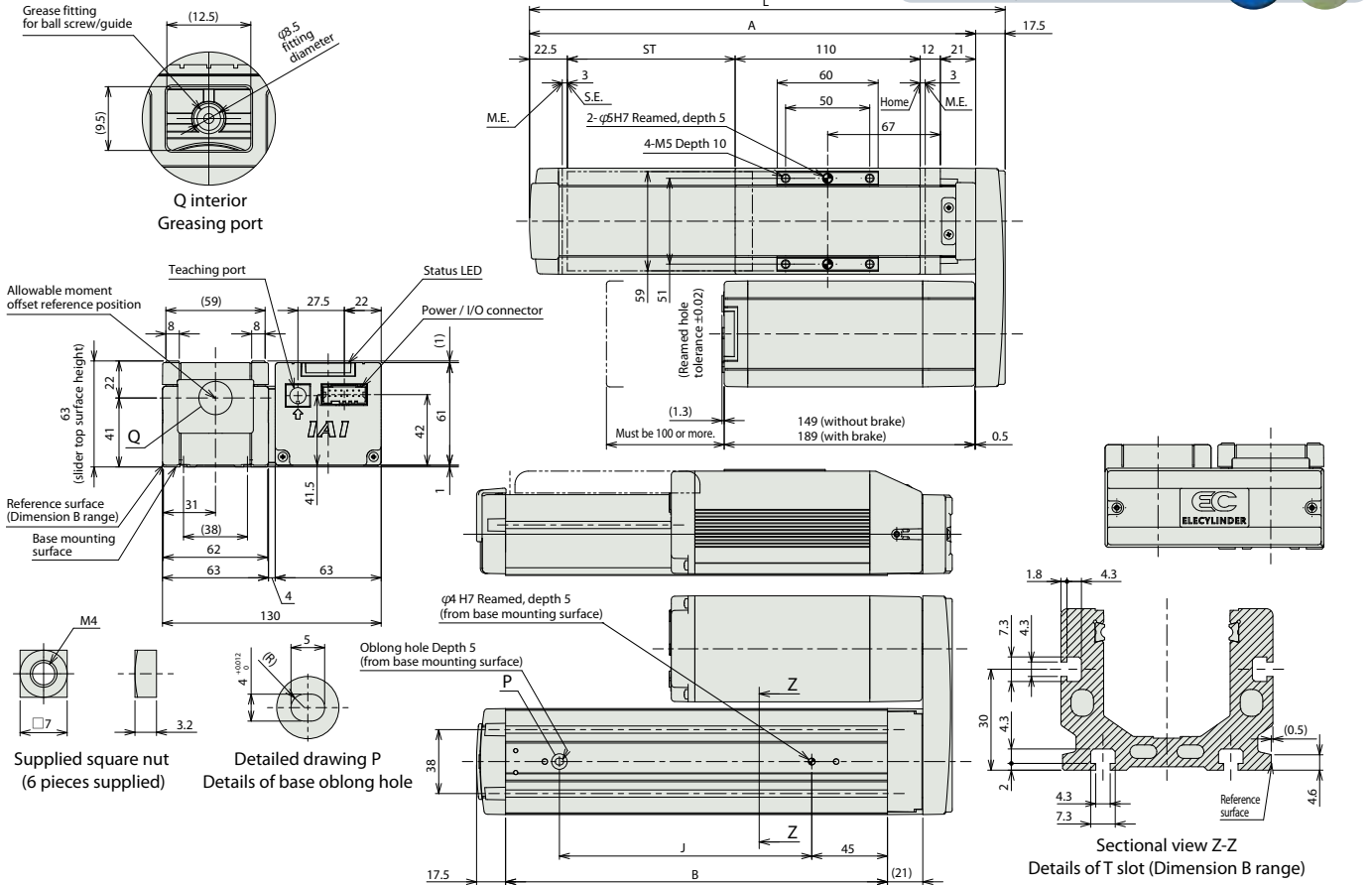

■ Dimensions by stroke

Stroke	50	100	150	200	250	300	350	400
L	233	283	333	383	433	483	533	583
A	215.5	265.5	315.5	365.5	415.5	465.5	515.5	565.5
B	177	227	277	327	377	427	477	527
J	100	150	200	250	300	350	400	450

■ Mass by stroke

Weight (kg)	Stroke	50	100	150	200	250	300	350	400
	without brake		2.2	2.4	2.6	2.8	3	3.2	3.4
with brake		2.4	2.6	2.8	3	3.2	3.4	3.6	3.8

Applicable controller

(Note) The EC series is equipped with a built-in controller. Please refer to P116 for details.

EC-S7□R

Simple dust-proof

Side-mounted Motor

Body width 70 mm

24v Stepper motor

Model Specification Items

EC	—	S7	<input type="text"/>	R	—	<input type="text"/>	—	<input type="text"/>	—	<input type="text"/>	—	<input type="text"/>
Series		Type	Lead	Specification		Stroke		Cable Length		Options		Refer to the option price list below
			S 24mm H 16mm M 8mm L 4mm	R Side-mounted motor		50 1 500	50mm 500mm (per 50mm)	0 1 1 10	Terminal type with connector 1m 1 10m			

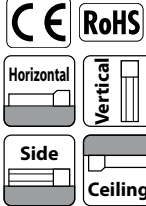

(Note) The above photo shows motor side-mounted to the left (ML).



- (1) The actuator specifications display the payload's maximum value, but it will vary depending on the acceleration and speed. Please refer to "Table of Payload by Speed/Acceleration" for more details.
- (2) When performing a push-motion operation, please refer to the "Correlation between push force and current limit value." Push force is only a guide. Please refer to P109 for cautions.
- (3) Depending on the ambient operating temperature, duty control is necessary. Please refer to P109 for cautions.
- (4) Special attention needs to be paid to the mounting orientation. Please refer to P33 for details.
- (5) Reference value of the overhang load length is under 280mm in the Ma, Mb and Mc directions. Please refer to the illustration on P35 for the overhang load length.
- (6) The center of gravity of the attached object should be less than 1/2 of the overhang distance. Even when the overhang distance and load moment are within the allowable range, the operating conditions should be moderated if some abnormal vibration or noise is observed.

Options

Name	Option code	Reference page
Brake	B	See P.101
Foot bracket	FT	See P.103
Motor side-mounted to the left (Note 1)	ML	See P.105
Motor side-mounted to the right (Note 1)	MR	See P.105
Non-motor end specification	NM	See P.108
PNP specification	PN	See P.108
Split motor and controller power supply specification	TMD2	See P.109
Battery-less absolute encoder	WA	See P.109
Wireless communication specification	WL	See P.109
Wireless axis-operation specification	WL2	See P.109

(Note 1) Please make sure to enter a code in the option column of the model spec item.

Stroke

Stroke (mm)	EC-S7□R	Stroke (mm)	EC-S7□R
50	○	300	○
100	○	350	○
150	○	400	○
200	○	450	○
250	○	500	○

Cable length

Cable code	Cable length
0	No cable (connector supplied)
1 ~ 3	1 ~ 3m
4 ~ 5	4 ~ 5m
6 ~ 10	6 ~ 10m

(Note) Robot cables.

Main specifications

Item		Description				
Lead	Ball screw lead (mm)	24	16	8	4	
	Payload	Max. payload (kg) (energy-saving disabled)	37	46	51	51
		Max. payload (kg) (energy-saving enabled)	18	35	40	40
Horizontal	Speed/acceleration/deceleration	Max. speed (mm/s)	860	700	420	190
		Min. speed (mm/s)	30	20	10	5
		Rated acceleration/deceleration (G)	0.3	0.3	0.3	0.3
		Max. acceleration/deceleration (G)	1	1	1	1
Vertical	Payload	Max. payload (kg) (energy-saving disabled)	3	8	16	19
		Max. payload (kg) (energy-saving enabled)	2	5	10	15
	Speed/acceleration/deceleration	Max. speed (mm/s)	860	700	350	175
Min. speed (mm/s)		30	20	10	5	
Rated acceleration/deceleration (G)		0.3	0.3	0.3	0.3	
Max. acceleration/deceleration (G)		0.5	0.5	0.5	0.5	
Push force	Max. thrust force when pushing (N)*	139	209	418	836	
	Max. speed when pushing (mm/s)	20	20	20	20	
Brake	Brake specification	Non-excitation actuating solenoid brake				
	Brake holding force (kgf)	3	8	16	19	
Stroke	Min. stroke (mm)	50	50	50	50	
	Max. stroke (mm)	500	500	500	500	
	Stroke pitch (mm)	50	50	50	50	

* Speed limitation applies to push motion. See the manual or contact IAI.

Item	Description
Driving system	Ball screw φ12mm, Rolling C10
Positioning repeatability	±0.05mm
Lost motion	-
Base	Dedicated aluminum extruded material(A6063SS-T5 or equivalent) Black alumite treatment
Linear guide	Linear motion infinite circulating type
Static allowable moment	Ma: 79N·m
	Mb: 114N·m
	Mc: 157N·m
Dynamic allowable moment (Note 2)	Ma: 17N·m
	Mb: 25N·m
	Mc: 34N·m
Ambient operation temperature/humidity	0~40°C, RH 85% or less (Non-condensing)
Degree of protection	IP20
Vibration & shock resistance	4.9m/s ² 100Hz or less
Overseas standards	CE Marking, RoHS (Restriction of Hazardous Substances)
Motor type	Stepper motor
Encoder type	Incremental / battery-less absolute
Number of encoder pulses	800 pulse/rev

(Note 2) Based on the standard rated operation life of 5,000 km. Operation life varies depending on operating and mounting conditions. Confirm the operation life on P36.

Table of Payload by Speed and Acceleration

Energy-saving disabled The unit for payload is kg. Operations in the blank locations are not possible.

Lead 24

Orientation	Horizontal					Vertical				
	Acceleration (G)					Acceleration (G)				
Speed (mm/s)	0.3	0.5	0.7	1	0.3	0.5	0.7	1	0.3	0.5
0	37	22	16	14	3	3				
200	37	22	16	14	3	3				
420	34	20	16	14	3	3				
640	18	13	9	7.5	3	3				
860	9	6	4	3	1.5	1				

Lead 16

Orientation	Horizontal					Vertical				
	Acceleration (G)					Acceleration (G)				
Speed (mm/s)	0.3	0.5	0.7	1	0.3	0.5				
0	46	35	28	27	8	8				
140	46	35	28	27	8	8				
280	46	35	25	24	8	8				
420	34	25	15	10	5	4.5				
560	20	14	8	6	3	2.5				
700	10	5	3	1	1.5	1				

Lead 8

Orientation	Horizontal					Vertical				
	Acceleration (G)					Acceleration (G)				
Speed (mm/s)	0.3	0.5	0.7	1	0.3	0.5				
0	51	45	40	40	16	16				
70	51	45	40	40	16	16				
140	51	40	38	35	16	16				
210	51	35	30	24	10	9.5				
280	36	20	15	15	8	7				
350	20	5	4		3	2				
420	2									

Lead 4

Orientation	Horizontal					Vertical				
	Acceleration (G)					Acceleration (G)				
Speed (mm/s)	0.3	0.5	0.7	1	0.3	0.5				
0	51	45	40	40	19	19				
35	51	45	40	40	19	19				
70	51	45	40	40	19	19				
105	51	45	40	35	19	19				
140	45	35	30	25	12.5	12				
175	30	16			5	4				
190	5									

■ Energy-saving enabled The unit for payload is kg. Operations in the blank locations are not possible.

Lead 24

Orientation	Horizontal			Vertical
	Acceleration (G)			
Speed (mm/s)	0.3	0.7	0.3	
0	18	10	2	
200	18	10	2	
420	18	10	2	
640	10	2	1	
800	1			

Lead 16

Orientation	Horizontal			Vertical
	Acceleration (G)			
Speed (mm/s)	0.3	0.7	0.3	
0	35	20	5	
140	35	20	5	
280	25	12	3	
420	15	6	1.5	
500	7.5	1.5	0.5	
560	2			

Lead 8

Orientation	Horizontal			Vertical
	Acceleration (G)			
Speed (mm/s)	0.3	0.7	0.3	
0	40	25	10	
70	40	25	10	
140	40	25	7	
210	25	14	4	
280	5		0.5	

Lead 4

Orientation	Horizontal			Vertical
	Acceleration (G)			
Speed (mm/s)	0.3	0.7	0.3	
0	40	30	15	
35	40	30	15	
70	40	30	15	
105	40	30	8	
120	15	6	2	

■ Direction of slider type moment

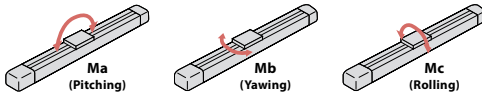

■ Stroke and maximum speed

Lead (mm)	Energy-saving mode	50-300 (per 50mm)	350 (mm)	400 (mm)	450 (mm)	500 (mm)
24	Disabled	860	774	619	506	
	Enabled	800 <640>	774 <640>	619	506	
16	Disabled	700	631	492	395	323
	Enabled	560 <500>	492	395	323	
8	Disabled	420 <350>	322	251	200	164
	Enabled	280	251	200	164	
4	Disabled	190 <175>	163	126	101	83
	Enabled	10	101	83		

(Note) Figures in <> represent vertical operations. (Unit is mm/s)

■ Correlation between push force and current limit value

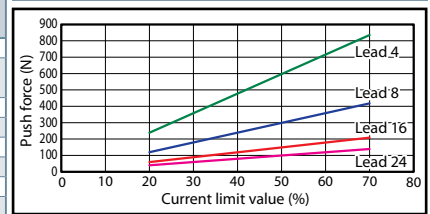

■ Dimensions

(Note) When the slider is returning to its home position, please be careful of interference from surrounding objects, as it will travel until it reaches the M.E.
 (Note) The drawing below represents motor side-mounted to the left (ML).

CAD drawings can be downloaded from our website.

www.intelligentactuator.com

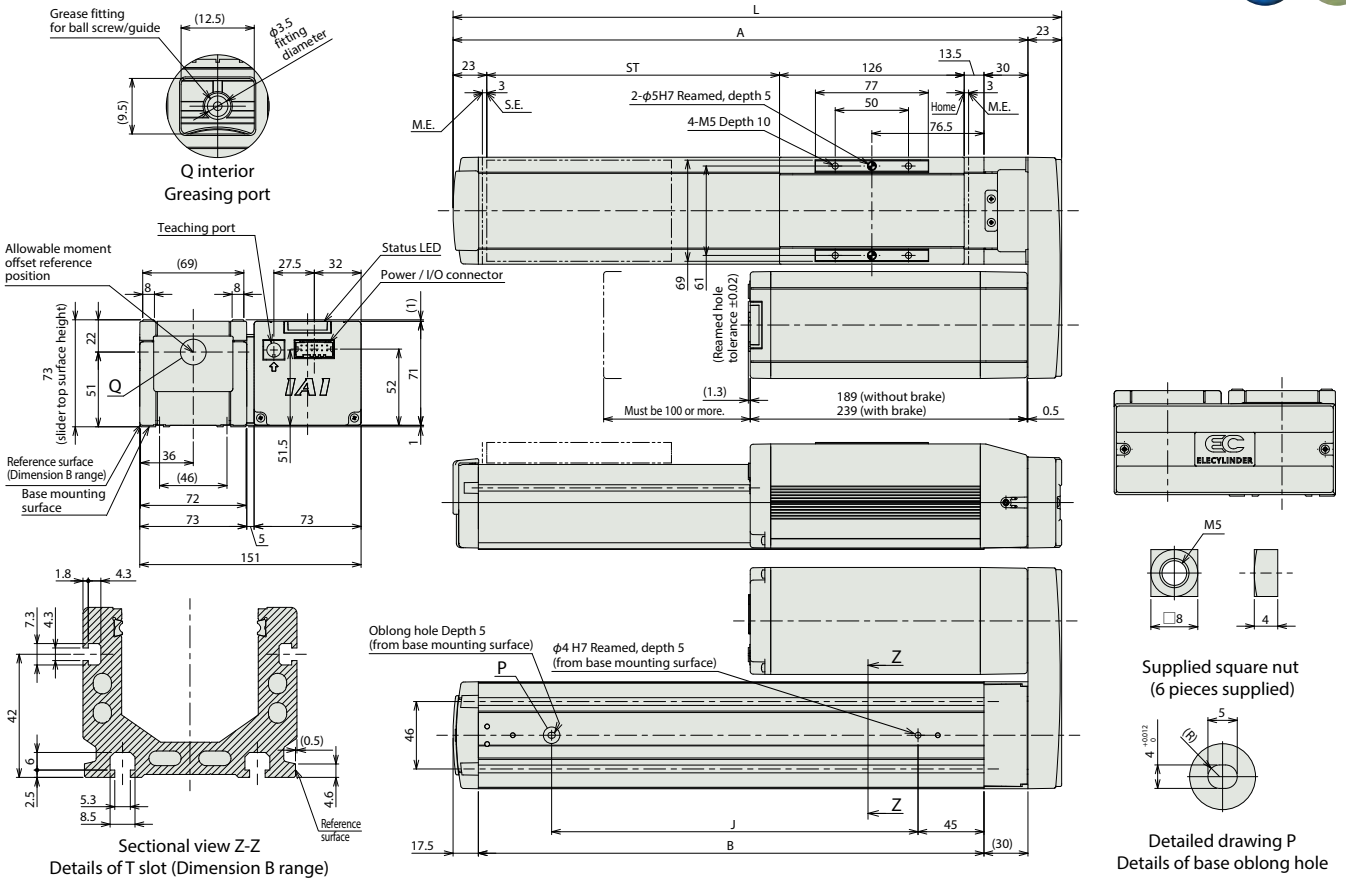

■ Dimensions by stroke

Stroke	50	100	150	200	250	300	350	400	450	500
L	265.5	315.5	365.5	415.5	465.5	515.5	565.5	615.5	665.5	715.5
A	242.5	292.5	342.5	392.5	442.5	492.5	542.5	592.5	642.5	692.5
B	195	245	295	345	395	445	495	545	595	645
J	100	150	200	250	300	350	400	450	500	550

■ Mass by stroke

Stroke	50	100	150	200	250	300	350	400	450	500	
Weight (kg)	without brake	4.2	4.4	4.7	4.9	5.2	5.4	5.7	5.9	6.2	6.4
	with brake	4.7	4.9	5.2	5.4	5.7	5.9	6.2	6.4	6.7	6.9

■ Applicable controller

(Note) The EC series is equipped with a built-in controller. Please refer to P117 for details.

EC-S6□AHR

High Rigidity

Simple dust-proof

Side-mounted Motor

Body width 63 mm

24v Stepper motor

Model Specification Items

EC	—	S6	□	AHR	—	□	—	□	—	□																				
Series	—	Type	Lead	Specification	—	Stroke	—	Cable Length	—	Options																				
		<table border="1" style="font-size: 8px;"> <tr><td>S</td><td>20mm</td></tr> <tr><td>H</td><td>12mm</td></tr> <tr><td>M</td><td>6mm</td></tr> <tr><td>L</td><td>3mm</td></tr> </table>	S	20mm	H	12mm	M	6mm	L	3mm	AHR	High rigidity with Side-mounted motor		<table border="1" style="font-size: 8px;"> <tr><td>50</td><td>50mm</td></tr> <tr><td>↑</td><td>↑</td></tr> <tr><td>800</td><td>800mm (per 50mm)</td></tr> </table>	50	50mm	↑	↑	800	800mm (per 50mm)		<table border="1" style="font-size: 8px;"> <tr><td>0</td><td>Terminal type with connector</td></tr> <tr><td>↑</td><td>↑</td></tr> <tr><td>10</td><td>10m</td></tr> </table>	0	Terminal type with connector	↑	↑	10	10m		Refer to the option price list below
S	20mm																													
H	12mm																													
M	6mm																													
L	3mm																													
50	50mm																													
↑	↑																													
800	800mm (per 50mm)																													
0	Terminal type with connector																													
↑	↑																													
10	10m																													

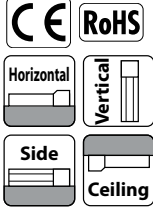

(Note) The above photo shows side-mounted motor to the left (ML).

- POINT Selection Notes**
- (1) The actuator specifications display the payload's maximum value, but it will vary depending on the acceleration and speed. Please refer to "Table of Payload by Speed/Acceleration" for more details.
 - (2) When performing a push-motion operation, please refer to the "Correlation between push force and current limit value." Push force is only a guide. Please refer to P109 for cautions.
 - (3) Depending on the ambient operating temperature, duty control is necessary. Please refer to P115 for cautions.
 - (4) Special attention needs to be paid to the mounting orientation. Please refer to P33 for details.
 - (5) Reference value of the overhang load length is under 300mm in the Ma, Mb and Mc directions. Please refer to the illustration on P35 for the overhang load length.
 - (6) The center of gravity of the attached object should be less than 1/2 of the overhang distance. Even when the overhang distance and load moment are within the allowable range, the operating conditions should be moderated if some abnormal vibration or noise is observed.

Stroke

Stroke (mm)	EC-S6□AHR	Stroke (mm)	EC-S6□AHR
50	○	450	○
100	○	500	○
150	○	550	○
200	○	600	○
250	○	650	○
300	○	700	○
350	○	750	○
400	○	800	○

Options

Name	Option code	Reference page
Brake	B	See P.101
Foot bracket	FT	See P.103
Side-mounted motor to the left (Note 1)	ML	See P.105
Side-mounted motor to the right (Note 1)	MR	See P.105
Non-motor end specification	NM	See P.108
PNP specification	PN	See P.108
Split motor and controller power supply specification	TMD2	See P.109
Battery-less absolute encoder	WA	See P.109
Wireless communication specification	WL	See P.109
Wireless axis-operation specification	WL2	See P.109

(Note 1) Please make sure to enter a code in the option column of the model spec item.

Cable length

Cable code	Cable length
0	No cable (connector supplied)
1 ~ 3	1 ~ 3m
4 ~ 5	4 ~ 5m
6 ~ 10	6 ~ 10m

(Note) Robot cables.

Main specifications

Item		Description				
Lead	Ball screw lead (mm)	20	12	6	3	
Horizontal	Payload	Max. payload (kg) (energy-saving disabled)	15	26	32	40
		Max. payload (kg) (energy-saving enabled)	8	14	20	25
	Speed/acceleration/deceleration	Max. speed (mm/s)	1120	900	450	225
		Min. speed (mm/s)	25	15	8	4
Vertical	Payload	Max. payload (kg) (energy-saving disabled)	1	2.5	6	16
		Max. payload (kg) (energy-saving enabled)	0.75	2	5	10
	Speed/acceleration/deceleration	Max. speed (mm/s)	1120	800	400	225
		Min. speed (mm/s)	25	15	8	4
Push force	Max. thrust force when pushing (N)*	67	112	224	449	
	Max. speed when pushing (mm/s)	20	20	20	20	
Brake	Brake specification	Non-excitation actuating solenoid brake				
	Brake holding force (kgf)	1	2.5	6	16	
Stroke	Min. stroke (mm)	50	50	50	50	
	Max. stroke (mm)	800	800	800	800	
	Stroke pitch (mm)	50	50	50	50	

* Speed limitation applies to push motion. See the manual or contact IAI.

Item	Description
Driving system	Ball screw φ10mm, Rolling C10
Positioning repeatability	±0.05mm
Lost motion	-
Base	Dedicated aluminum extruded material(A6063SS-T5 or equivalent) Black alumite treatment
Linear guide	Linear motion infinite circulating type
Static allowable moment	Ma: 48N·m
	Mb: 69N·m
	Mc: 103N·m
Dynamic allowable moment (Note 2)	Ma: 33N·m
	Mb: 40N·m
	Mc: 50N·m
Ambient operation temperature/humidity	0~40°C, RH 85% or less (Non-condensing)
Degree of protection	IP20
Vibration & shock resistance	4.9m/s ² 100Hz or less
Overseas standards	CE Marking, RoHS (Restriction of Hazardous Substances)
Motor type	Stepper motor
Encoder type	Incremental / battery-less absolute
Number of encoder pulses	800 pulse/rev

(Note 2) Based on the standard rated operation life of 5,000 km. Operation life varies depending on operating and mounting conditions. Confirm the operation life on P36.

Table of Payload by Speed and Acceleration

■ **Energy-saving disabled** The unit for payload is kg. Operations in the blank locations are not possible.

Lead 20

Orientation	Acceleration (G)					
	Horizontal		Vertical			
Speed (mm/s)	0.3	0.5	0.7	1	0.3	0.5
0	15	10	8	7	1	1
160	15	10	8	7	1	1
320	12	10	8	6	1	1
480	12	9	8	6	1	1
640	12	6.5	6	5	1	1
800	9	5	4	3	1	1
960	7	4	3	1.5	0.75	0.5
1120	5	2.5	1.5		0.5	

Lead 12

Orientation	Acceleration (G)					
	Horizontal		Vertical			
Speed (mm/s)	0.3	0.5	0.7	1	0.3	0.5
0	26	18	16	14	2.5	2.5
80	26	18	16	14	2.5	2.5
200	26	18	16	14	2.5	2.5
320	26	18	14	12	2.5	2.5
440	26	18	12	9	2.5	2.5
560	17.5	12	7	5	2.5	2.5
700	10	5	3.5	2	1	0.5
800	6	3	1		0.5	
900	3					

Lead 6

Orientation	Acceleration (G)					
	Horizontal		Vertical			
Speed (mm/s)	0.3	0.5	0.7	1	0.3	0.5
0	32	26	24	20	6	6
40	32	26	24	20	6	6
100	32	26	24	20	6	6
160	32	26	24	20	6	6
220	32	26	24	20	6	6
280	32	26	18	15	6	5.5
340	25	14	12	9	4	3.5
400	15	8	8	5	2	2
450	10	5				

Lead 3

Orientation	Acceleration (G)					
	Horizontal		Vertical			
Speed (mm/s)	0.3	0.5	0.7	1	0.3	0.5
0	40	35	35	35	16	16
50	40	35	35	35	16	16
80	40	35	35	30	16	16
110	40	35	35	30	16	16
140	40	35	35	28	15	15
170	40	32	25	20	9	8
200	28	20	15	8	6	4
225	18	5			2	

■ **Energy-saving enabled** The unit for payload is kg. Operations in the blank locations are not possible.

Lead 20

Orientation	Acceleration (G)		
	0.3	0.7	0.3
Speed (mm/s)			
0	8	5	0.75
160	8	5	0.75
320	8	5	0.75
480	8	4	0.75
640	6	3	0.75
800	4	1.5	0.5

Lead 12

Orientation	Acceleration (G)		
	0.3	0.7	0.3
Speed (mm/s)			
0	14	10	2
80	14	10	2
200	14	10	2
320	14	10	2
440	11	7	1.5
560	7	2.5	1
680	2		

Lead 6

Orientation	Acceleration (G)		
	0.3	0.7	0.3
Speed (mm/s)			
0	20	14	5
40	20	14	5
100	20	14	5
160	20	14	5
220	16	14	4
280	13	7	2.5
340	8	1	1

Lead 3

Orientation	Acceleration (G)		
	0.3	0.7	0.3
Speed (mm/s)			
0	25	22	10
20	25	22	10
50	25	22	10
80	25	22	10
110	20	14	8
140	15	11	5
170	11	5	2

■ **Direction of slider type moment**

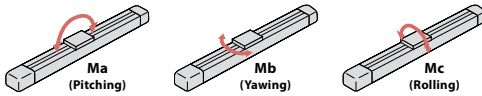

Stroke and maximum speed

Lead (mm)	Energy-saving mode	Stroke (mm)								
		50-400 (per 50mm)	450	500	550	600	650	700	750	800
20	Disabled	1120								
	Enabled		800							
12	Disabled	900 <800>	845 <800>	705	585	515	445	390	345	315
	Enabled		680 <560>		585 <560>	515	445	390	345	315
6	Disabled	450 <400>	415 <400>	350	295	255	220	190	170	140
	Enabled		340		295	255	220	190	170	140
3	Disabled	225	205	170	145	125	110	95	85	70
	Enabled		170		145	125	110	95	85	70

Correlation between push force and current limit value

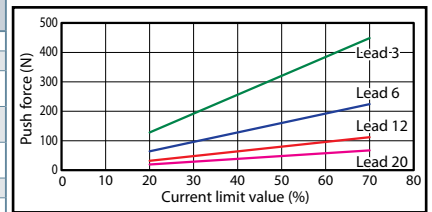

(Note) Figures in <> represent vertical operations. (Unit is mm/s)

Dimensions

(Note) When the slider is returning to its home position, please be careful of interference from surrounding objects, as it will travel until it reaches the M.E. (Note) The drawing below represents side-mounted motor to the left (ML).

CAD drawings can be downloaded from our website.

www.intelligentactuator.com

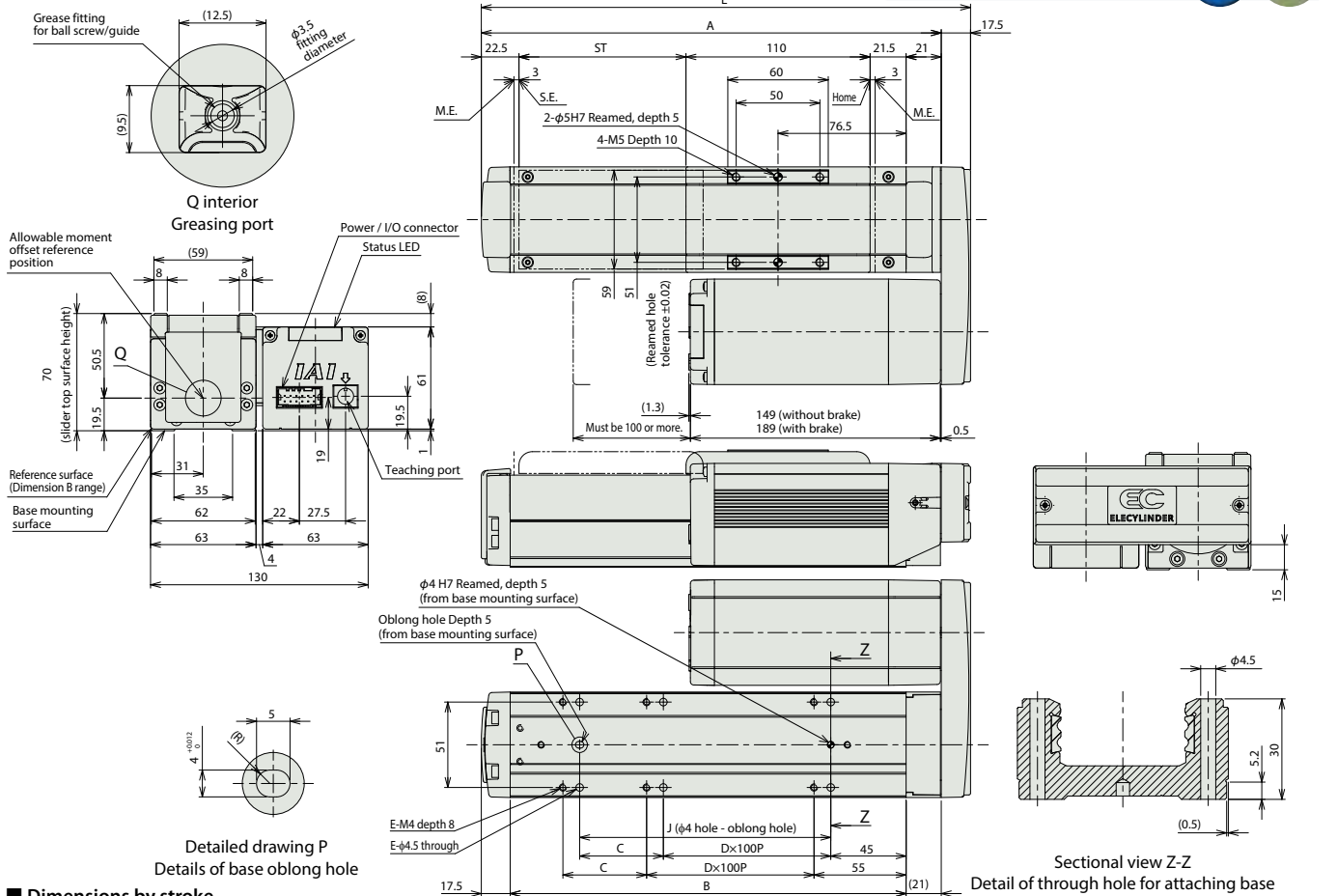

■ **Dimensions by stroke**

Stroke	50	100	150	200	250	300	350	400	450	500	550	600	650	700	750	800
L	242.5	292.5	342.5	392.5	442.5	492.5	542.5	592.5	642.5	692.5	742.5	792.5	842.5	892.5	942.5	992.5
A	225	275	325	375	425	475	525	575	625	675	725	775	825	875	925	975
B	186.5	236.5	286.5	336.5	386.5	436.5	486.5	536.5	586.5	636.5	686.5	736.5	786.5	836.5	886.5	936.5
C	0	50	0	50	0	50	0	50	0	50	0	50	0	50	0	50
D	1	1	2	2	3	3	4	4	5	5	6	6	7	7	8	8
E	4	6	6	8	8	10	10	12	12	14	14	16	16	18	18	20
J	100	150	200	250	300	350	400	450	500	550	600	650	700	750	800	850

■ **Mass by stroke**

Stroke	50	100	150	200	250	300	350	400	450	500	550	600	650	700	750	800
Weight (kg)	without brake	2.3	2.5	2.7	2.9	3.2	3.4	3.6	3.8	4.1	4.3	4.5	4.7	5	5.2	5.4
	with brake	2.6	2.8	3	3.2	3.5	3.7	3.9	4.1	4.4	4.6	4.8	5	5.3	5.5	5.7

■ **Applicable controller**

(Note) The EC series is equipped with a built-in controller. Please refer to P116 for details.

EC-S7□AHR

High Rigidity

High Rigidity

Simple dust-proof

Side-mounted Motor

Body width 75 mm

24V Stepper motor

Model Specification Items

EC	S7		AHR			
Series	Type	Lead	Specification	Stroke	Cable Length	Options
		S 24mm H 16mm M 8mm L 4mm	AHR High rigidity with Side-mounted motor	50 ↑ 800	50mm ↑ 800mm (per 50mm)	0 Terminal type with connector 1 1m ↑ 10 10m
			Options Refer to the option price list below			

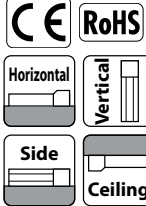

(Note) The above photo shows side-mounted motor to the left (ML).



- (1) The actuator specifications display the payload's maximum value, but it will vary depending on the acceleration and speed. Please refer to "Table of Payload by Speed/Acceleration" for more details.
- (2) When performing a push-motion operation, please refer to the "Correlation between push force and current limit value." Push force is only a guide. Please refer to P109 for cautions.
- (3) Depending on the ambient operating temperature, duty control is necessary. Please refer to P115 for cautions.
- (4) Special attention needs to be paid to the mounting orientation. Please refer to P33 for details.
- (5) Reference value of the overhang load length is under 300mm in the Ma, Mb and Mc directions. Please refer to the illustration on P35 for the overhang load length.
- (6) The center of gravity of the attached object should be less than 1/2 of the overhang distance. Even when the overhang distance and load moment are within the allowable range, the operating conditions should be moderated if some abnormal vibration or noise is observed.

Options

Name	Option code	Reference page
Brake	B	See P.101
Foot bracket	FT	See P.103
Side-mounted motor to the left (Note 1)	ML	See P.105
Side-mounted motor to the right (Note 1)	MR	See P.105
Non-motor end specification	NM	See P.108
PNP specification	PN	See P.108
Split motor and controller power supply specification	TMD2	See P.109
Battery-less absolute encoder	WA	See P.109
Wireless communication specification	WL	See P.109
Wireless axis-operation specification	WL2	See P.109

(Note 1) Please make sure to enter a code in the option column of the model spec item.

Cable length

Cable code	Cable length
0	No cable (connector supplied)
1 ~ 3	1 ~ 3m
4 ~ 5	4 ~ 5m
6 ~ 10	6 ~ 10m

(Note) Robot cables.

Main specifications

Item		Description				
Lead	Ball screw lead (mm)	24	16	8	4	
Horizontal	Payload	Max. payload (kg) (energy-saving disabled)	37	46	51	51
		Max. payload (kg) (energy-saving enabled)	18	35	40	40
		Max. speed (mm/s)	1080	840	420	190
Horizontal	Speed/acceleration/deceleration	Min. speed (mm/s)	30	20	10	5
		Rated acceleration/deceleration (G)	0.3	0.3	0.3	0.3
		Max. acceleration/deceleration (G)	1	1	1	1
		Max. payload (kg) (energy-saving disabled)	3	8	16	25
Vertical	Payload	Max. payload (kg) (energy-saving enabled)	2	5	10	15
		Max. speed (mm/s)	860	700	350	175
		Min. speed (mm/s)	30	20	10	5
Vertical	Speed/acceleration/deceleration	Rated acceleration/deceleration (G)	0.3	0.3	0.3	0.3
		Max. acceleration/deceleration (G)	0.5	0.5	0.5	0.5
		Max. thrust force when pushing (N)*	139	209	418	836
		Max. speed when pushing (mm/s)	20	20	20	20
Push force	Brake specification	Non-excitation actuating solenoid brake				
		Brake holding force (kgf)	3	8	16	25
Stroke	Brake	Min. stroke (mm)	50	50	50	50
		Max. stroke (mm)	800	800	800	800
		Stroke pitch (mm)	50	50	50	50

* Speed limitation applies to push motion. See the manual or contact IAI.

Item	Description
Driving system	Ball screw φ12mm, Rolling C10
Positioning repeatability	±0.05mm
Lost motion	-
Base	Dedicated aluminum extruded material(A6063S5-T5 or equivalent) Black alumite treatment
Linear guide	Linear motion infinite circulating type Ma: 115N·m Mb: 115N·m Mc: 229N·m Ma: 75N·m Mb: 90N·m Mc: 134N·m
Static allowable moment	
Dynamic allowable moment (Note 2)	
Ambient operation temperature/humidity	0~40°C, RH 85% or less (Non-condensing)
Degree of protection	IP20
Vibration & shock resistance	4.9m/s ² 100Hz or less
Overseas standards	CE Marking, RoHS (Restriction of Hazardous Substances)
Motor type	Stepper motor
Encoder type	Incremental / battery-less absolute
Number of encoder pulses	800 pulse/rev

(Note 2) Based on the standard rated operation life of 5,000 km. Operation life varies depending on operating and mounting conditions. Confirm the operation life on P36.

Table of Payload by Speed and Acceleration

■ Energy-saving disabled The unit for payload is kg. Operations in the blank locations are not possible.

Lead 24

Orientation	Speed (mm/s)	Acceleration (G)					
		0.3	0.5	0.7	1	0.3	0.5
0	37	22	16	14	3	3	
200	37	22	16	14	3	3	
420	34	20	16	11	3	3	
640	15	10	8	6.5	3	2	
860	9	6	4	3	1.5	1	
1080	3	2					
1230	3	1.5	1	0.5	0.5		

Lead 16

Orientation	Speed (mm/s)	Acceleration (G)					
		0.3	0.5	0.7	1	0.3	0.5
0	46	35	28	27	8	8	
140	46	35	28	27	8	8	
280	46	35	25	24	8	8	
420	30	25	15	10	5	4.5	
560	15	12	7	5	3	2.5	
700	10	5	3	1	1.5	1	
840	3						
980	4						

Lead 8

Orientation	Speed (mm/s)	Acceleration (G)					
		0.3	0.5	0.7	1	0.3	0.5
0	51	45	40	40	16	16	
70	51	45	40	40	16	16	
140	51	40	38	35	16	16	
210	51	35	30	24	9	8	
280	35	20	15	12.5	6	5	
350	20	5	4		3	2	
420	2						

Lead 4

Orientation	Speed (mm/s)	Acceleration (G)					
		0.3	0.5	0.7	1	0.3	0.5
0	51	45	40	40	25	25	
35	51	45	40	40	25	25	
70	51	45	40	40	25	25	
105	51	45	40	35	20	19	
140	45	35	30	25	12.5	10	
175	20	15			4	3	
190	5						

■ **Energy-saving enabled** The unit for payload is kg. Operations in the blank locations are not possible.

Lead 24

Orientation	Horizontal			Vertical
	Acceleration (G)			
Speed (mm/s)	0.3	0.7	0.3	
0	18	10	2	2
200	18	10	2	2
420	18	10	2	2
640	10	2	1	1
800	1			

Lead 16

Orientation	Horizontal			Vertical
	Acceleration (G)			
Speed (mm/s)	0.3	0.7	0.3	
0	35	20	5	5
140	35	20	5	5
280	25	12	3	3
420	15	6	1.5	1.5
500	7.5	1.5	0.5	0.5
560	2			

Lead 8

Orientation	Horizontal			Vertical
	Acceleration (G)			
Speed (mm/s)	0.3	0.7	0.3	
0	40	25	10	10
70	40	25	10	10
140	40	25	7	7
210	25	14	4	4
280	5		0.5	0.5

Lead 4

Orientation	Horizontal			Vertical
	Acceleration (G)			
Speed (mm/s)	0.3	0.7	0.3	
0	40	30	15	15
35	40	30	15	15
70	40	30	15	15
105	40	30	8	8
120	15	6	2	2

■ **Direction of slider type moment**

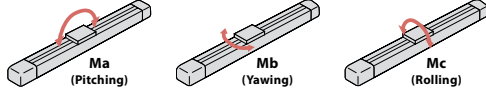

Correlation between push force and current limit value

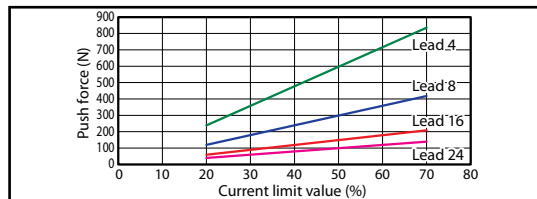

Stroke and maximum speed

Lead (mm)	Energy-saving mode	50-500 (per 50mm)	550 (mm)	600 (mm)	650 (mm)	700 (mm)	750 (mm)	800 (mm)
24	Disabled	1080 <860>			950	840	750	
	Enabled	800 <640>				750 <640>		
16	Disabled	840 <700>	820 <700>	715 <700>	625	555	495	
	Enabled	560 <500>				555 <500>	495	
8	Disabled	420 <350>	405 <350>	350	310	275	245	
	Enabled	280				275	245	
4	Disabled	190 <175>		175	150	135	120	
	Enabled	120						

(Note) Figures in <> represent vertical operations.

(Unit is mm/s)

Dimensions

(Note) When the slider is returning to its home position, please be careful of interference from surrounding objects, as it will travel until it reaches the M.E.
 (Note) The drawing below represents side-mounted motor to the left (ML).

CAD drawings can be downloaded from our website.
www.intelligentactuator.com

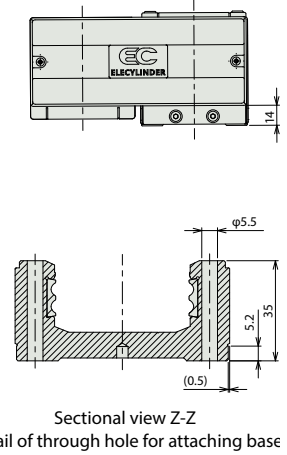
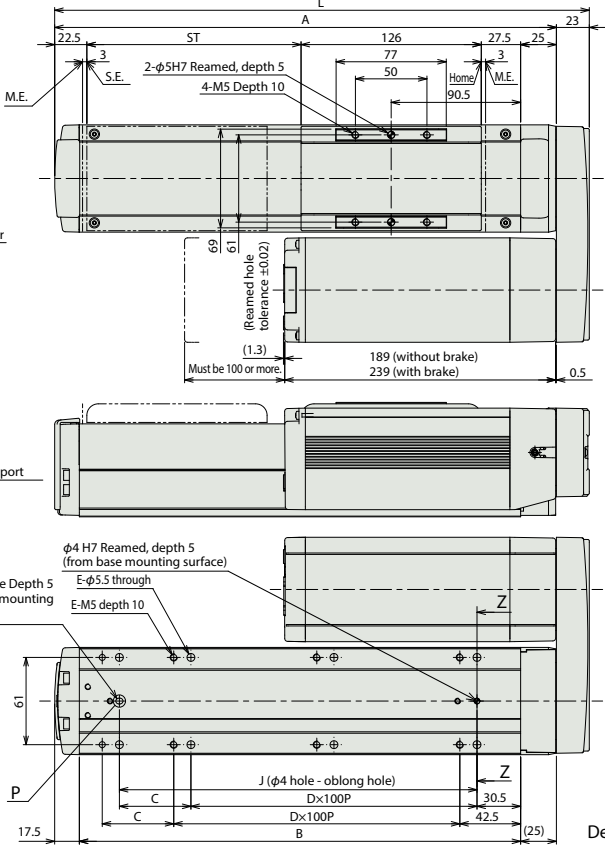
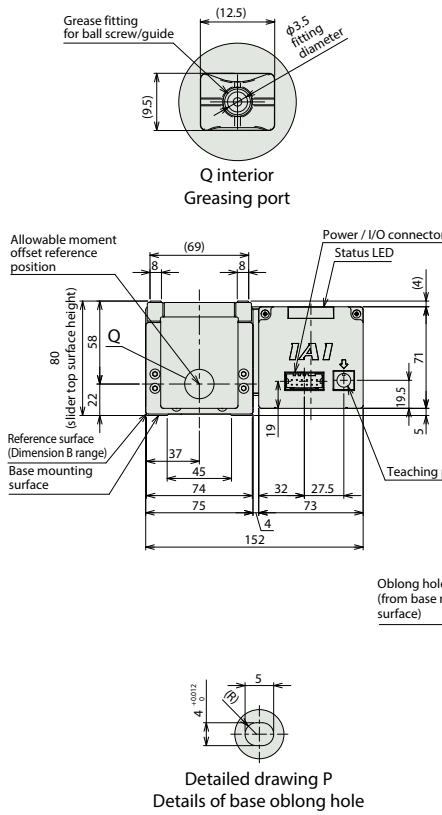

■ **Dimensions by stroke**

Stroke	50	100	150	200	250	300	350	400	450	500	550	600	650	700	750	800
L	274	324	374	424	474	524	574	624	674	724	774	824	874	924	974	1024
A	251	301	351	401	451	501	551	601	651	701	751	801	851	901	951	1001
B	208.5	258.5	308.5	358.5	408.5	458.5	508.5	558.5	608.5	658.5	708.5	758.5	808.5	858.5	908.5	958.5
C	50	0	50	0	50	0	50	0	50	0	50	0	50	0	50	0
D	1	2	2	3	3	4	4	5	5	6	6	7	7	8	8	9
E	6	6	8	8	10	10	12	12	14	14	16	16	18	18	20	20
J	150	200	250	300	350	400	450	500	550	600	650	700	750	800	850	900

■ **Mass by stroke**

Weight (kg)	Stroke	50	100	150	200	250	300	350	400	450	500	550	600	650	700	750	800
	without brake		4.5	4.7	5	5.3	5.5	5.8	6.1	6.3	6.6	6.9	7.1	7.4	7.7	7.9	8.2
with brake		5.0	5.2	5.5	5.8	6.0	6.3	6.6	6.8	7.1	7.4	7.6	7.9	8.2	8.4	8.7	9.0

■ **Applicable controller**

(Note) The EC series is equipped with a built-in controller. Please refer to P116 for details.

EC-R6



Model Specification Items

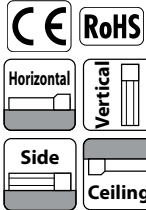
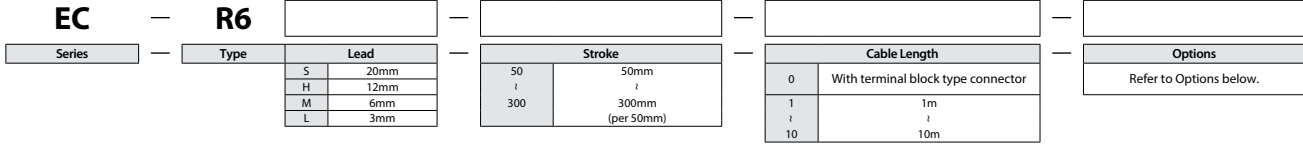

- POINT Selection Notes**
- (1) The actuator specifications display the payload's maximum value, but it will vary depending on the acceleration and speed. Please refer to "Table of Payload by Speed/Acceleration" for more details.
 - (2) The value of the horizontal payload assumes that there is an external guide. Please be aware that the anti-rotation stopper can be damaged when an external force is applied to the rod from any direction other than the moving direction.
 - (3) When performing a push-motion operation, please refer to the "Correlation graph between push force and current limit value." Push force is only a Reference value. Please refer to P115 for details.
 - (4) Limit on duty may be needed depending on the ambient operation temperature. Please refer to P109 for details.
 - (5) Special attention needs to be paid to the mounting orientation. Please refer to P33 for details.

Stroke			
Stroke (mm)	EC-R6	Stroke (mm)	EC-R6
50	○	200	○
100	○	250	○
150	○	300	○

Cable Length	
Cable code	Cable length
0	No cable (with connector)
1 ~ 3	1 ~ 3m
4 ~ 5	4 ~ 5m
6 ~ 10	6 ~ 10m

(Note) Robot cables.

Options			
Type	Option code	Reference page	
Brake	B	See P.101	
Flange (front)	FL	See P.102	
Foot bracket	FT	See P.103	
Tip adapter (Internal thread)	NFA	See P.106	
Non-motor end specification	NM	See P.108	
PNP specification	PN	See P.108	
Split motor and controller power supply specification	TMD2	See P.109	
Battery-less Absolute Encoder specification	WA	See P.109	
Wireless communication specification	WL	See P.109	
Wireless axis-operation specification	WL2	See P.109	

Main specifications				
Item		Description		
Lead	Ball screw lead (mm)	20	12	6 3
Horizontal	Payload	Max. payload (kg) (energy-saving disabled)	6	25 40 60
		Max. payload (kg) (energy-saving enabled)	6	25 40 40
	Max. speed (mm/s)	800	700 450 225	
	Speed/acceleration/deceleration	Min. speed (mm/s)	25	15 8 4
		Rated acceleration/deceleration (G)	0.3	0.3 0.3 0.3
Max. acceleration/deceleration (G)		1	1 1 1	
Vertical	Payload	Max. payload (kg) (energy-saving disabled)	1.5	4 10 12.5
		Max. payload (kg) (energy-saving enabled)	1	4 10 12.5
	Max. speed (mm/s)	800	700 450 225	
	Speed/acceleration/deceleration	Min. speed (mm/s)	25	15 8 4
		Rated acceleration/deceleration (G)	0.3	0.3 0.3 0.3
Max. acceleration/deceleration (G)		0.5	0.5 0.5 0.5	
Push force	Pushing max. thrust force (N)*	67	112 224 449	
	Pushing max. speed (mm/s)	20	20 20 20	
Brake	Brake holding specification	Non-excitation actuating solenoid brake		
	Brake holding force (kgf)	1.5	4 10 12.5	
Stroke	Min. stroke (mm)	50	50 50 50	
	Max. stroke (mm)	300	300 300 300	
	Stroke pitch (mm)	50	50 50 50	

Item		Description		
Driving system	Ball screw ϕ 10mm, Rolling C10			
Positioning repeatability	\pm 0.05mm			
Lost motion	-			
Rod	ϕ 25mm Material: Aluminum Hard alumite treatment			
Rod non-rotation accuracy (Note 1)	\pm 1.5 degree			
Allowable load and torque on the rod tip.	0.5N·m			
Ambient operation temperature/humidity	0~40°C, 85%RH or less (Non-condensing)			
Degree of protection	IP20			
Vibration & shock resistance	4.9m/s ² 100Hz or less			
Overseas standards	CE marking, RoHS (Restriction of Hazardous Substances)			
Motor type	Stepper motor			
Encoder type	Incremental / battery-less absolute			
Number of encoder pulses	800 pulse/rev			

(Note 1) The rod tip displacement angle (initial reference value) when allowable static torque is applied on rod tip when most of the rod is in the body.

* Speed limitation applies to push motion. See the manual or contact IAI.

Table of Payload by Speed/Acceleration

Setting for energy-saving disabled Unit for payload is kg. Operations on the blank locations are not possible.

Lead 20

Orientation	Horizontal Acceleration (G)						Vertical Acceleration (G)						
	0.3	0.5	0.7	1	0.3	0.5	0.3	0.5	0.7	1	0.3	0.5	
Speed (mm/s)	0	6	6	5	5	1.5	1.5	0	6	5	5	1.5	1.5
160	6	6	5	5	1.5	1.5	0	6	5	5	1.5	1.5	
320	6	6	5	3	1.5	1.5	0	6	5	3	1.5	1.5	
480	6	6	5	3	1.5	1.5	0	6	5	3	1.5	1.5	
640	6	4	3	2	1.5	1.5	0	6	4	3	2	1.5	1.5
800	4	3			1	1	0	6	3		1	1	

Lead 12

Orientation	Horizontal Acceleration (G)						Vertical Acceleration (G)							
	0.3	0.5	0.7	1	0.3	0.5	0.3	0.5	0.7	1	0.3	0.5		
Speed (mm/s)	0	25	18	16	12	4	4	0	25	18	16	12	4	4
100	25	18	16	12	4	4	0	25	18	16	12	4	4	
200	25	18	16	10	4	4	0	25	18	16	10	4	4	
400	20	14	10	6	4	4	0	20	14	10	6	4	4	
500	15	8	6	4	3.5	3	0	15	8	6	4	3.5	3	
700	6	2			2	1	0	6	2		2	1		

Lead 6

Orientation	Horizontal Acceleration (G)						Vertical Acceleration (G)							
	0.3	0.5	0.7	1	0.3	0.5	0.3	0.5	0.7	1	0.3	0.5		
Speed (mm/s)	0	40	35	30	25	10	10	0	40	35	30	25	10	10
50	40	35	30	25	10	10	0	40	35	30	25	10	10	
100	40	35	30	25	10	10	0	40	35	30	25	10	10	
200	40	30	25	20	10	10	0	40	30	25	20	10	10	
250	40	27.5	22.5	18	9	8	0	40	27.5	22.5	18	9	8	
350	30	14	12	10	5	5	0	30	14	12	10	5	5	
400	18	10	6	5	3	3	0	18	10	6	5	3	3	
450	8	3			2	1	0	8	3		2	1		

Lead 3

Orientation	Horizontal Acceleration (G)						Vertical Acceleration (G)							
	0.3	0.5	0.7	1	0.3	0.5	0.3	0.5	0.7	1	0.3	0.5		
Speed (mm/s)	0	60	50	45	40	12.5	12.5	0	60	50	45	40	12.5	12.5
50	60	50	45	40	12.5	12.5	0	60	50	45	40	12.5	12.5	
100	60	50	45	40	12.5	12.5	0	60	50	45	40	12.5	12.5	
125	60	50	40	30	10	10	0	60	50	40	30	10	10	
175	40	35	25	20	6	5	0	40	35	25	20	6	5	
200	35	30	20	14	5	4.5	0	35	30	20	14	5	4.5	
225	16	16	10	6	5	4	0	16	16	10	6	5	4	

■ Setting for energy-saving enabled Unit for payload is kg.

Lead 20

Orientation	Horizontal			Vertical
	Acceleration (G)			
Speed (mm/s)	0.3	0.7	0.3	
0	6	5	1	
160	6	5	1	
320	6	5	1	
480	4	3	1	
640	3	1	0.5	

Lead 12

Orientation	Horizontal			Vertical
	Acceleration (G)			
Speed (mm/s)	0.3	0.7	0.3	
0	25	10	4	
100	25	10	4	
200	25	10	4	
300	20	8	3	
400	10	5	2	
500	5	2	1	

Lead 6

Orientation	Horizontal			Vertical
	Acceleration (G)			
Speed (mm/s)	0.3	0.7	0.3	
0	40	20	10	
50	40	20	10	
100	40	20	10	
150	40	20	8	
200	35	18	5	
250	10	6	3	

Lead 3

Orientation	Horizontal			Vertical
	Acceleration (G)			
Speed (mm/s)	0.3	0.7	0.3	
0	40	25	12.5	
25	40	25	12.5	
50	40	25	12.5	
75	40	25	12	
100	40	25	9	
125	40	25	5	

Stroke and maximum speed

Lead (mm)	Energy-saving mode	50-200 (per 50mm)	250 (mm)	300 (mm)
20	Disabled		800	
	Enabled		640	
12	Disabled	700		547
	Enabled		500	
6	Disabled	450	376	268
	Enabled		250	
3	Disabled	255	186	133
	Enabled		125	

(Unit is mm/s)

Correlation between push force and current limit value

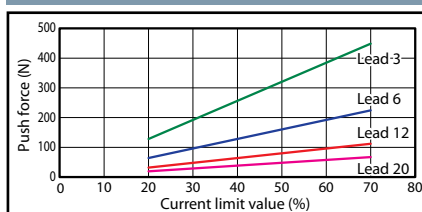

Dimensions

*1 When the rod is returning to its home position, please be careful of interference from surrounding objects, as it will travel until it reaches the M.E.
 *2 The direction of width across flats varies depending on the product. Those flats cannot be used for reference plane.

CAD drawings can be downloaded from our website.
www.intelligentactuator.com

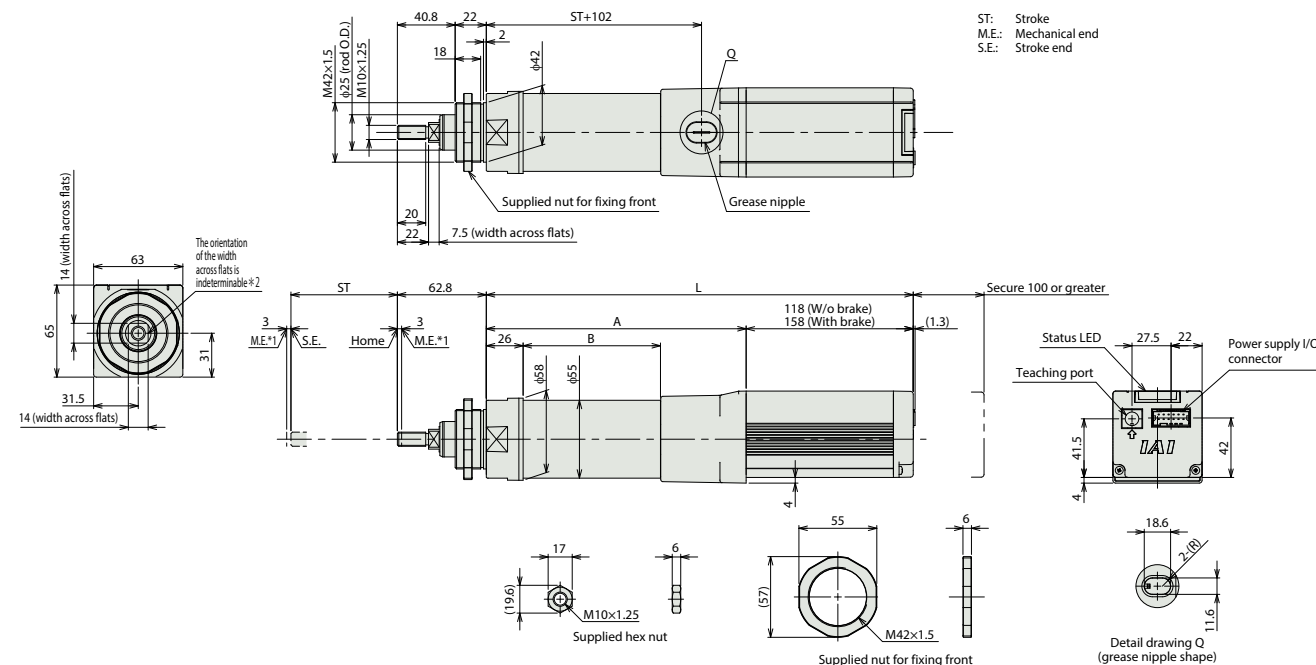

■ Dimensions by stroke

L	Stroke	50	100	150	200	250	300
	W/o Brake		301.5	351.5	401.5	451.5	501.5
With Brake		341.5	391.5	441.5	491.5	541.5	591.5
A		183.5	233.5	283.5	333.5	383.5	433.5
B		97	147	197	247	297	347

■ Mass by stroke

Weight (kg)	Stroke	50	100	150	200	250	300
	W/o Brake		1.6	1.8	2	2.2	2.4
With Brake		1.8	2	2.2	2.4	2.6	2.8

Applicable controller

(Note) The EC series is equipped with a built-in controller. Please refer to P116 for details.

EC-R7



Model Specification Items

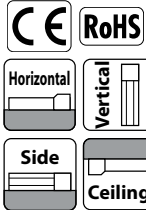
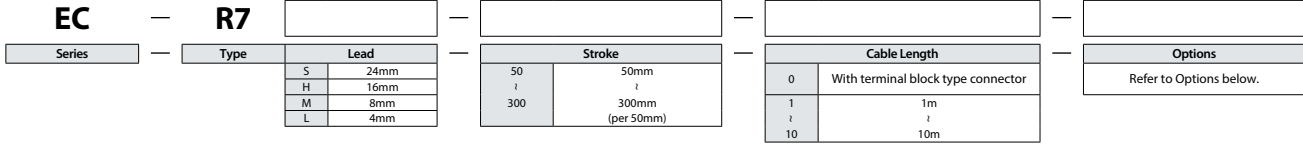

- POINT Selection Notes**
- (1) The actuator specifications display the payload's maximum value, but it will vary depending on the acceleration and speed. Please refer to "Table of Payload by Speed/Acceleration" for more details.
 - (2) The value of the horizontal payload assumes that there is an external guide. Please be aware that the anti-rotation stopper can be damaged when an external force is applied to the rod from any direction other than the moving direction.
 - (3) When performing a push-motion operation, please refer to the "Correlation between push force and current limit value." Push force is only a guide. Please refer to P115 for details.
 - (4) Depending on the ambient operating temperature, duty control is necessary. Please refer to P109 for details.
 - (5) Special attention needs to be paid to the mounting orientation. Please refer to P33 for details.

Stroke (mm)	EC-R7	Stroke (mm)	EC-R7
50	○	200	○
100	○	250	○
150	○	300	○

Cable code	No cable (connector supplied)
0	No cable (with connector)
1 ~ 3	1 ~ 3m
4 ~ 5	4 ~ 5m
6 ~ 10	6 ~ 10m

(Note) Robot cables.

Type	Option code	Reference page
Brake	B	See P.101
Flange (front)	FL	See P.102
Foot bracket	FT	See P.103
Tip adapter (Internal thread)	NFA	See P.106
Non-motor end specification	NM	See P.108
PNP specification	PN	See P.108
Split motor and controller power supply specification	TMD2	See P.109
Battery-less Absolute Encoder specification	WA	See P.109
Wireless communication specification	WL	See P.109
Wireless axis-operation specification	WL2	See P.109

Main specifications

Item		Description				
Lead	Ball screw lead (mm)	24	16	8	4	
Horizontal	Payload	Max. payload (kg) (energy-saving disabled)	20	50	60	80
		Max. payload (kg) (energy-saving enabled)	18	40	50	55
	Max. speed (mm/s)	860	700	350	175	
	Speed/acceleration/deceleration	Min. speed (mm/s)	30	20	10	5
		Rated acceleration/deceleration (G)	0.3	0.3	0.3	0.3
Max. acceleration/deceleration (G)		1	1	1	1	
Vertical	Payload	Max. payload (kg) (energy-saving disabled)	3	8	18	19
		Max. payload (kg) (energy-saving enabled)	3	5	17.5	19
	Speed/acceleration/deceleration	Max. speed (mm/s)	640	560	350	175
Min. speed (mm/s)		30	20	10	5	
Rated acceleration/deceleration (G)		0.3	0.3	0.3	0.3	
Push force	Max. acceleration/deceleration (G)	0.5	0.5	0.5	0.5	
	Pushing max. thrust force (N)*	182	273	547	1094	
Brake	Pushing max. speed (mm/s)	20	20	20	20	
	Brake holding specification	Non-excitation actuating solenoid brake				
Stroke	Brake holding force (kgf)	3	8	18	19	
	Min. stroke (mm)	50	50	50	50	
	Max. stroke (mm)	300	300	300	300	
	Stroke pitch (mm)	50	50	50	50	

Item	Description
Driving system	Ball screw ϕ 12mm, Rolling C10
Positioning repeatability	\pm 0.05mm
Lost motion	-
Rod	ϕ 30mm Material: Aluminum Hard alumite treatment
Rod non-rotation accuracy (Note 1)	\pm 1.5 degree
Allowable load and torque on the rod tip.	0.5N·m
Ambient operation temperature/humidity	0~40°C, 85%RH or less (Non-condensing)
Degree of protection	IP20
Vibration & shock resistance	4.9m/s ² 100Hz or less
Overseas standards	CE marking, RoHS (Restriction of Hazardous Substances)
Motor type	Stepper motor
Encoder type	Incremental / battery-less absolute
Number of encoder pulses	800 pulse/rev

(Note 1) The rod tip displacement angle (initial Reference value) when allowable static torque is applied on rod tip when most of the rod is in the body.

* Speed limitation applies to push motion. See the manual or contact IAI.

Table of Payload by Speed and Acceleration

Setting for energy-saving disabled Unit for payload is kg. Operations on the blank locations are not possible.

Lead 24

Orientation	Acceleration (G)					
	0.3	0.5	0.7	1	0.3	0.5
Speed (mm/s)						
0	20	18	15	12	3	3
200	20	18	15	12	3	3
400	20	14	12	8	3	3
420	17	12	10	6	3	3
600	14	6	5	4	3	2
640	5	3	2	1.5	2	1
800	5	1	1			
860	2	0.5				

Lead 16

Orientation	Acceleration (G)					
	0.3	0.5	0.7	1	0.3	0.5
Speed (mm/s)						
0	50	40	35	30	8	8
140	50	40	35	30	8	8
280	50	35	25	20	7	7
420	25	18	14	10	4.5	4
560	10	5	3	2	2	1
700	2					

Lead 8

Orientation	Acceleration (G)					
	0.3	0.5	0.7	1	0.3	0.5
Speed (mm/s)						
0	60	50	45	40	18	18
70	60	50	45	40	18	18
140	60	50	45	40	16	12
210	60	40	31	26	10	9
280	34	20	15	11	5	4
350	12	4	1	2	1	1

Lead 4

Orientation	Acceleration (G)					
	0.3	0.5	0.7	1	0.3	0.5
Speed (mm/s)						
0	80	70	65	60	19	19
35	80	70	65	60	19	19
70	80	70	65	60	19	19
105	80	60	50	40	18	18
140	50	30	20	15	12	10
175	15				2	

■ Setting for energy-saving enabled Unit for payload is kg. Operations on the blank locations are not possible

Lead 24

Orientation	Horizontal			Vertical
	Acceleration (G)			
Speed (mm/s)	0.3	0.7	0.3	
0	18	9.5	3	
200	18	9.5	3	
400	11	6	1.5	
420	10	5		
600	1			

Lead 16

Orientation	Horizontal			Vertical
	Acceleration (G)			
Speed (mm/s)	0.3	0.7	0.3	
0	40	25	5	
140	40	25	5	
280	18	12	2	
420	1.5	1		

Lead 8

Orientation	Horizontal			Vertical
	Acceleration (G)			
Speed (mm/s)	0.3	0.7	0.3	
0	50	30	17.5	
70	50	30	17.5	
140	50	30	7	
210	14	7	2	

Lead 4

Orientation	Horizontal			Vertical
	Acceleration (G)			
Speed (mm/s)	0.3	0.7	0.3	
0	55	50	19	
35	55	50	19	
70	55	50	13	
105	30	15	2	

Stroke and maximum speed

Lead (mm)	Energy-saving mode	50-300 (per 50mm)
24	Disabled	860<640>
	Enabled	600<400>
16	Disabled	700<560>
	Enabled	420<280>
8	Disabled	350
	Enabled	210
4	Disabled	175
	Enabled	105

(Note) Figures in < > represent vertical operation. (Unit is mm/s)

Correlation between push force and current limit value

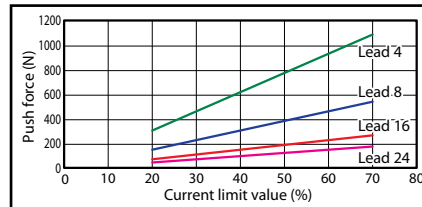

Dimensions

*1 When the rod is returning to its home position, please be careful of interference from surrounding objects, as it will travel until it reaches the M.E.
*2 The direction of width across flats varies depending on the product. Those flats cannot be used for reference plane.

CAD drawings can be downloaded from our website.
www.intelligentactuator.com

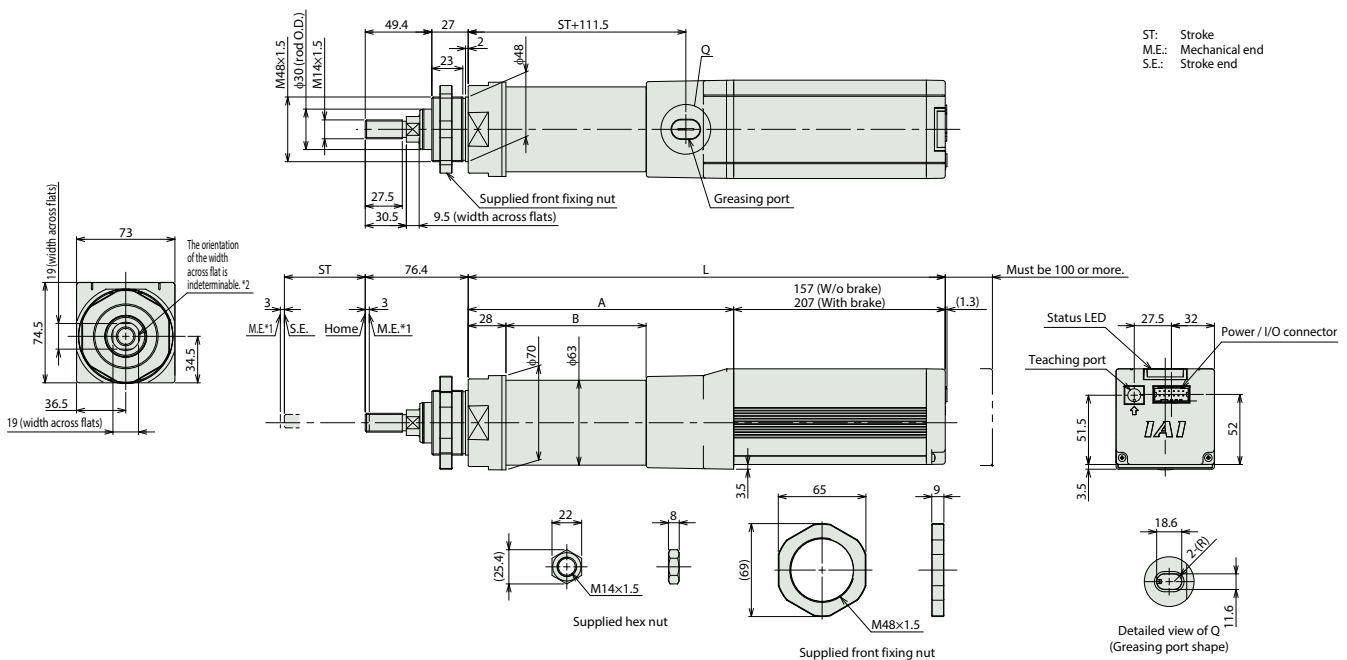

■ Dimensions by stroke

L	Stroke	50	100	150	200	250	300
	W/o Brake	354	404	454	504	554	604
With Brake	404	454	504	554	604	654	
A	197	247	297	347	397	447	
B	104	154	204	254	304	354	

■ Mass by stroke

Weight (kg)	Stroke	50	100	150	200	250	300
	W/o Brake	3.3	3.5	3.7	3.9	4.1	4.3
With Brake	3.5	3.7	3.9	4.1	4.3	4.5	

Applicable controller

(Note) The EC series is equipped with a built-in controller. Please refer to P116 for details.

EC-RR3



Model Specification Items

EC	—	RR3				
Series	—	Type	Lead	Stroke	Cable Length	Options
		H	6mm	50	0	Refer to the option price list below
		M	4mm	100	Terminal type with connector	
		L	2mm	300	1	
					10	

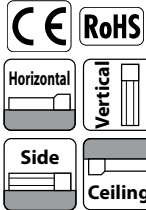

Radial load specification Radial Cylinder™

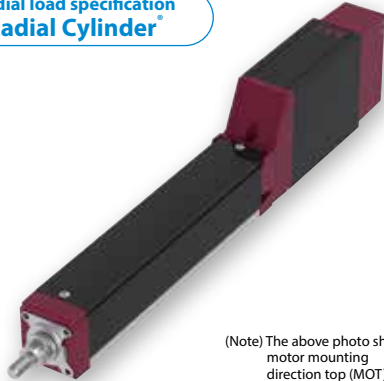

(Note) The above photo shows motor mounting direction top (MOT).



- (1) The actuator specifications display the payload's maximum value, but it will vary depending on the acceleration and speed. Please refer to "Table of Payload by Speed/Acceleration" for more details.
- (2) The Radial Cylinder is equipped with a guide. Please refer to P111 for details of the radial loads applied to the rod.
- (3) The value of the horizontal payload assumes the use of an external guide.
- (4) When performing a push-motion operation, please refer to the "Correlation between push force and current limit value." Push force is only a guide.
- (5) Special attention needs to be paid to the mounting orientation. Please refer to P33 for details.

Stroke			
Stroke (mm)	EC-RR3	Stroke (mm)	EC-RR3
50	○	200	○
100	○	250	○
150	○	300	○

Cable length	
Cable code	Cable length
0	No cable (with connector)
1 ~ 3	1 ~ 3m
4 ~ 5	4 ~ 5m
6 ~ 10	6 ~ 10m

(Note) Robot cables

Options			
Name	Option code	Reference page	
Brake	B	See P.101	
Tip adapter (flange)	FFA	See P.101	
Frang (front)	FL	See P.102	
Foot bracket (front)	FT	See P.103	
Motor mounting direction change (bottom) (Note 1)	MOB	See P.105	
Motor mounting direction change (left) (Note 1)	MOL	See P.105	
Motor mounting direction change (right) (Note 1)	MOR	See P.105	
Motor mounting direction change (top) (Note 1)	MOT	See P.105	
Tip adapter (female screw)	NFA	See P.106	
Non-motor end specification	NM	See P.108	
PNP specification	PN	See P.108	
Split motor and controller power supply specification	TMD2	See P.109	
Battery-less absolute encoder	WA	See P.109	
Wireless communication specification	WA	See P.109	
Wireless axis-operation specification	WL2	See P.109	

(Note 1) Please make sure to enter a code in the option column of the model spec item.

Stroke and maximum speed				
Lead (mm)	50-150 (per 50mm)	200 (mm)	250 (mm)	300 (mm)
6	420	300	210	150
4	280	200	140	100
2	140	100	70	50

(unit is mm/s)

Main specifications			
Item		Description	
Lead	Ball screw lead (mm)	6	4
	Max. payload (kg)	9	14
	Max. speed (mm/s)	420	280
	Min. speed (mm/s)	8	5
	Rated acceleration/deceleration (G)	0.3	0.3
Horizontal	Speed/acceleration/deceleration	0.3	0.3
	Max. acceleration/deceleration (G)	0.5	0.3
	Max. payload (kg)	1.5	2.5
	Max. speed (mm/s)	420	280
	Min. speed (mm/s)	8	5
Vertical	Speed/acceleration/deceleration	0.3	0.3
	Max. acceleration/deceleration (G)	0.3	0.3
	Max. thrust force when pushing (N)*	45	68
	Max. speed when pushing (mm/s)	20	20
	Max. speed when pushing (mm/s)	20	20
Push force	Max. thrust force when pushing (N)*	45	68
	Max. speed when pushing (mm/s)	20	20
	Max. speed when pushing (mm/s)	20	20
Brake	Brake specification	Non-excitation actuating solenoid brake	
	Brake holding force (kgf)	1.5	2.5
	Min. stroke (mm)	50	50
Stroke	Max. stroke (mm)	300	300
	Stroke pitch (mm)	50	50
	Stroke pitch (mm)	50	50

(Note 2) The rod tip displacement angle when no load is applied.

* Speed limitation applies to push motion. See the manual or contact IAI.

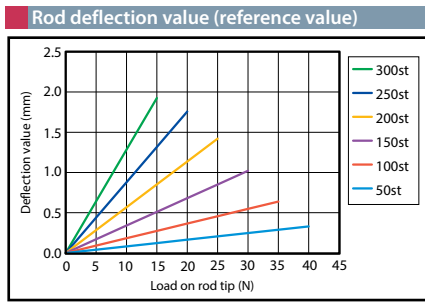
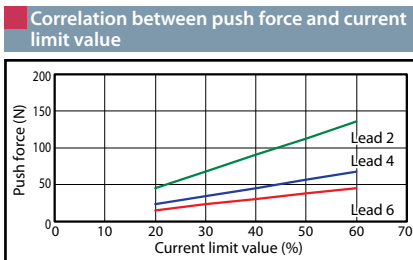

Table of Payload by Speed/Acceleration

Unit of payload is kg.

Lead 6			Lead 4			Lead 2		
Orientation	Horizontal	Vertical	Orientation	Horizontal	Vertical	Orientation	Horizontal	Vertical
Speed (mm/s)	Acceleration (G)	0.3	Speed (mm/s)	Acceleration (G)	0.3	Speed (mm/s)	Acceleration (G)	0.3
0	9	7	0	14	2.5	0	18	3.5
120	9	7	80	14	2.5	40	18	3.5
210	9	7	140	14	2.5	70	18	3.5
255	9	7	170	14	2.5	85	18	3.5
315	9	7	210	14	2.5	105	18	3.5
360	8	6	240	13	2.5	120	18	3
420	6	5	280	12	2	140	17	2.5

Dimensions

*1 When the rod is returning to its home position, please be careful of interference from surrounding objects, as it will travel until it reaches the M.E.
 *2 The drawing below represents motor mounting direction top (MOT).
 *3 The direction of width across flats varies depending on the product. This flat cannot be used for reference plane.

CAD drawings can be downloaded from our website.
www.intelligentactuator.com

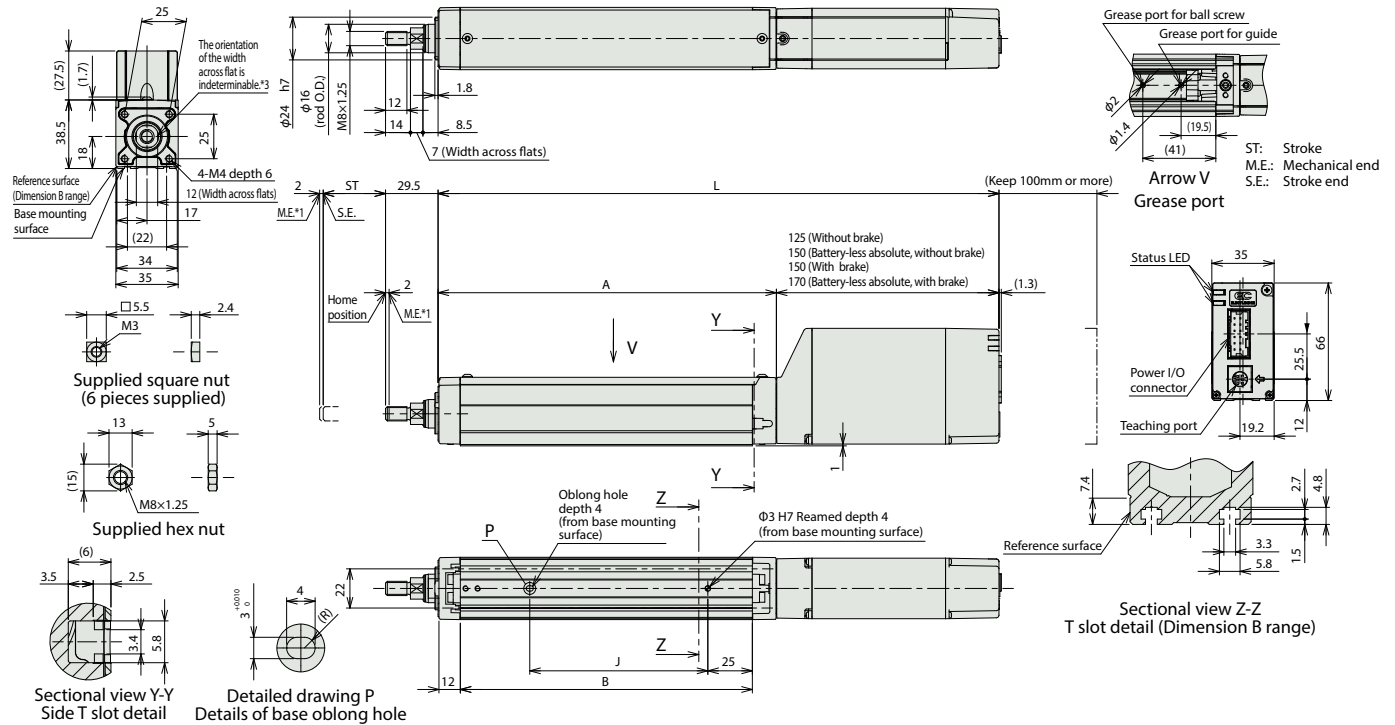

Motor mounting direction change (optional)

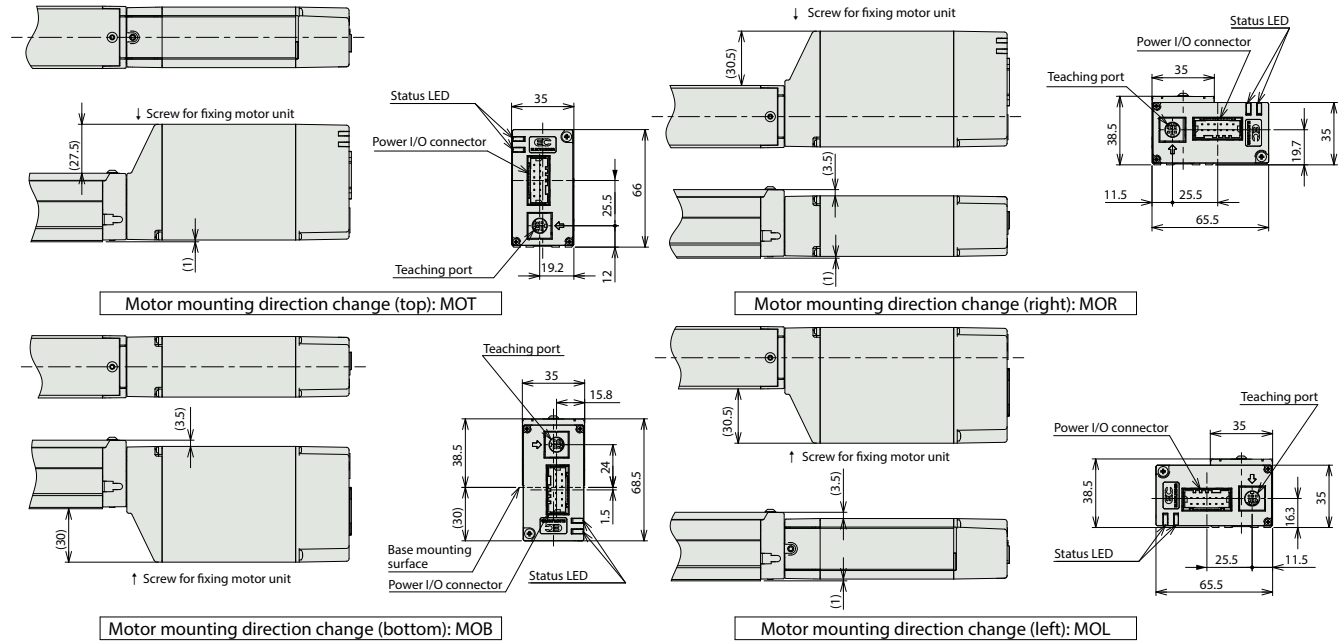

Dimensions by stroke

Stroke		50	100	150	200	250	300	
L	Incremental	Without brake	265	315	365	415	465	515
		With brake	290	340	390	440	490	540
	Battery-less absolute	Without brake	290	340	390	440	490	540
		With brake	310	360	410	460	510	560
A		140	190	240	290	340	390	
B		114	164	214	264	314	364	
J		50	100	150	200	250	300	

Mass by stroke

Stroke		50	100	150	200	250	300
Weight (kg)	Without brake	0.8	0.9	1	1.1	1.2	1.3
	With brake	0.9	1	1.1	1.2	1.3	1.4

Applicable controller

(Note) The EC series is equipped with a built-in controller. Please refer to P116 for details.

EC-RR4



Model Specification Items

EC	—	RR4				
Series	Type	Lead	Stroke	Cable Length	Options	
		S 16mm H 10mm M 5mm L 2.5mm	50 100 300 (per 50mm)	0 Terminal type with connector 1 1m 5 5m 10 10m	Refer to the option price list below	

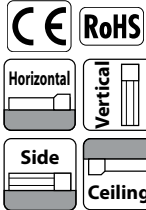

Radial load specification Radial Cylinder™

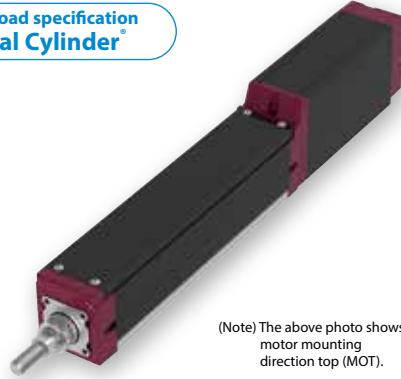

(Note) The above photo shows motor mounting direction top (MOT).



- (1) The actuator specifications display the payload's maximum value, but it will vary depending on the acceleration and speed. Please refer to "Table of Payload by Speed/Acceleration" for more details.
- (2) The Radial Cylinder is equipped with a guide. Please refer to P111 for details of the radial loads applied to the rod.
- (3) The value of the horizontal payload assumes the use of an external guide.
- (4) When performing a push-motion operation, please refer to the "Correlation between push force and current limit value." Push force is only a guide.
- (5) Special attention needs to be paid to the mounting orientation. Please refer to P33 for details.

Options

Name	Option code	Reference page
Brake	B	See P.101
Tip adapter (flange)	FFA	See P.101
Flange (front)	FL	See P.102
Foot bracket	FT	See P.103
Motor mounting direction change (bottom) (Note 1)	MOB	See P.105
Motor mounting direction change (left) (Note 1)	MOL	See P.105
Motor mounting direction change (right) (Note 1)	MOR	See P.105
Motor mounting direction change (top) (Note 1)	MOT	See P.105
Tip adapter (female screw)	NFA	See P.106
Non-motor end specification	NM	See P.108
PNP specification	PN	See P.108
Split motor and controller power supply specification	TMD2	See P.109
Battery-less absolute encoder	WA	See P.109
Wireless communication specification	WL	See P.109
Wireless axis-operation specification	WL2	See P.109

(Note 1) Please make sure to enter a code in the option column of the model spec item.

Stroke

Stroke (mm)	EC-RR4	Stroke (mm)	EC-RR4
50	○	200	○
100	○	250	○
150	○	300	○

Cable length

Cable code	Cable length
0	No cable (with connector)
1 ~ 3	1 ~ 3m
4 ~ 5	4 ~ 5m
6 ~ 10	6 ~ 10m

(Note) Robot cables

Main specifications

Item	Description			
Lead	Ball screw lead (mm) 16 10 5 2.5			
Horizontal	Payload Max. payload (kg) (energy-saving disabled) Max. payload (kg) (energy-saving enabled) Speed/acceleration/deceleration Max. speed (mm/s) Min. speed (mm/s) Rated acceleration/deceleration (G) Max. acceleration/deceleration (G)	7 16 25 35 5 10 22 35 800 700 350 175 40 30 7 4 0.3 0.3 0.3 0.3 1 1 0.5 0.3		
	Vertical	Payload Max. payload (kg) (energy-saving disabled) Max. payload (kg) (energy-saving enabled) Speed/acceleration/deceleration Max. speed (mm/s) Min. speed (mm/s) Rated acceleration/deceleration (G) Max. acceleration/deceleration (G)	1.5 2.5 5 6.5 1 2 4.5 6.5 800 700 350 150 40 30 7 4 0.3 0.3 0.3 0.3 0.5 0.5 0.5 0.3	
		Push force	Max. thrust force when pushing (N)* Max. speed when pushing (mm/s)	41 66 132 263 40 30 20 20
		Brake	Brake specification Brake holding force (kgf) Min. stroke (mm)	Non-excitation actuating solenoid brake 1.5 2.5 5 6.5 50 50 50 50
		Stroke	Max. stroke (mm) Stroke pitch (mm)	300 300 300 300 50 50 50 50

Item	Description
Driving system	Ball screw φ8mm, Rolling C10
Positioning repeatability	±0.05mm
Lost motion	-
Linear guide	Linear motion infinite circulating type
Rod	φ20mm, Material: aluminum, Hard alumite treatment
Rod no-rotation precision (Note 2)	0 degree
Ambient operation temperature/humidity	0 to 40°C, RH 85% or less (Non-condensing)
Degree of protection	IP20
Vibration & shock resistance	4.9m/s ² , 100Hz or less
Overseas standards	CE Marking, RoHS (Restriction of Hazardous Substances)
Motor type	Stepper motor
Encoder type	Incremental / battery-less absolute
Number of encoder pulses	800 pulse /rev.

(Note 2) The rod tip displacement angle when no load is applied.

* Speed limitation applies to push motion. See the manual or contact IAI.

Correlation between push force and current limit value

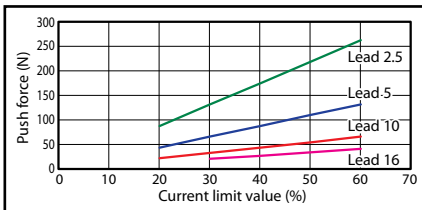

Table of Payload by Speed and Acceleration/Deceleration

Energy-saving disabled

The unit for payload is kg. Operations in the blank locations are not possible

Lead 16		Lead 10		Lead 5		Lead 2.5	
Orientation	Acceleration (G)	Orientation	Acceleration (G)	Orientation	Acceleration (G)	Orientation	Acceleration (G)
Speed (mm/s)	0.3 0.7 1	Speed (mm/s)	0.3 0.7 1	Speed (mm/s)	0.3 0.7 1	Speed (mm/s)	0.3 0.7 1
0	7 6 5 3.5 1.5 1.25	0	16 15 13 11 2.5 2	0	25 22 5 4.5	0	35 6.5
140	7 6 5 3.5 1.5 1.25	175	16 15 13 11 2.5 2	85	25 22 5 4.5	40	35 6.5
280	7 6 4.5 3.5 1.5 1.25	350	16 11 11 7.5 2.5 2	130	25 22 5 4.5	85	35 6.5
420	7 6 3.5 2.5 1.5 1.25	435	15 9 8 6.5 2.5 2	215	25 22 5 4.5	105	35 6.5
560	6.5 5.5 3.5 2.5 1.5 1.25	525	11 7 5.5 4.5 2.5 2	260	25 22 5 4.5	135	32 6
700	5.5 3.5 2.5 1.5 1 1	600	7 4.5 3.5 2.5 2 2	300	22 18 5 4	150	30 6
800	1 1 1 1 1 1	700	2.5 1.5 1 1 1 1	350	18 11 3 3	175	28

Energy-saving enabled

The unit for payload is kg. Operations in the blank locations are not possible

Lead 16		Lead 10		Lead 5		Lead 2.5	
Orientation	Acceleration (G)	Orientation	Acceleration (G)	Orientation	Acceleration (G)	Orientation	Acceleration (G)
Speed (mm/s)	0.3 0.7 1	Speed (mm/s)	0.3 0.7 1	Speed (mm/s)	0.3 0.7 1	Speed (mm/s)	0.3 0.7 1
0	5 3 1	0	10 6.5 2	0	22 4.5	0	35 6.5
140	5 3 1	175	10 6.5 2	85	22 4.5	40	35 6.5
280	5 3 1	350	9 6.5 2	130	22 4.5	85	35 6.5
420	4 3 1	435	5 2.5 1.5	215	18 3	105	30 6
560	3 1.5 1	525	1 1 1	260	12 2	135	25 3.5

Stroke and maximum speed

Lead (mm)	Energy-saving	50-150 (per 50mm)	200 (mm)	250 (mm)	300 (mm)
16	disabled	800	600	440	
	enabled	560		440	
10	disabled	700	570	390	290
	enabled	525		390	290
5	disabled	350	280	190	140
	enabled	260		190	140
2.5	disabled	175 <150>	135	90	70
	enabled	135		90	70

Figures in <> represent vertical operations. (Unit is mm/s)

Rod deflection value (reference value)

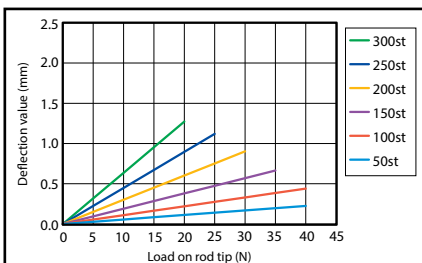

Dimensions

*1 The dimensions represent for wireless communication specification (optional) or wireless axis-operation specification (optional).
 *2 When the rod is returning to its home position, please be careful of interference from surrounding objects, as it will travel until it reaches the M.E.
 *3 The drawing below represents motor mounting direction top (MOT).
 *4 The direction of width across flats varies depending on the product. This flat cannot be used for reference plane.

CAD drawings can be downloaded from our website.
www.intelligentactuator.com

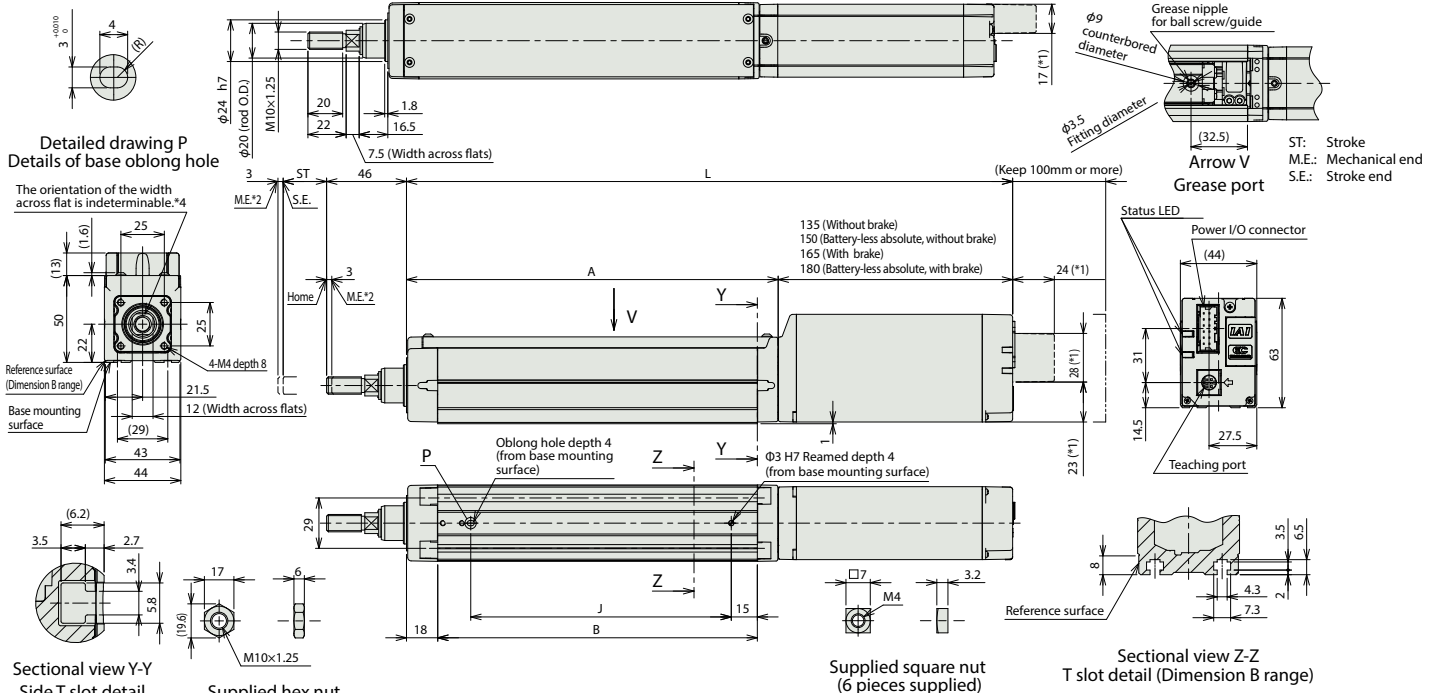

Motor mounting direction change (optional)

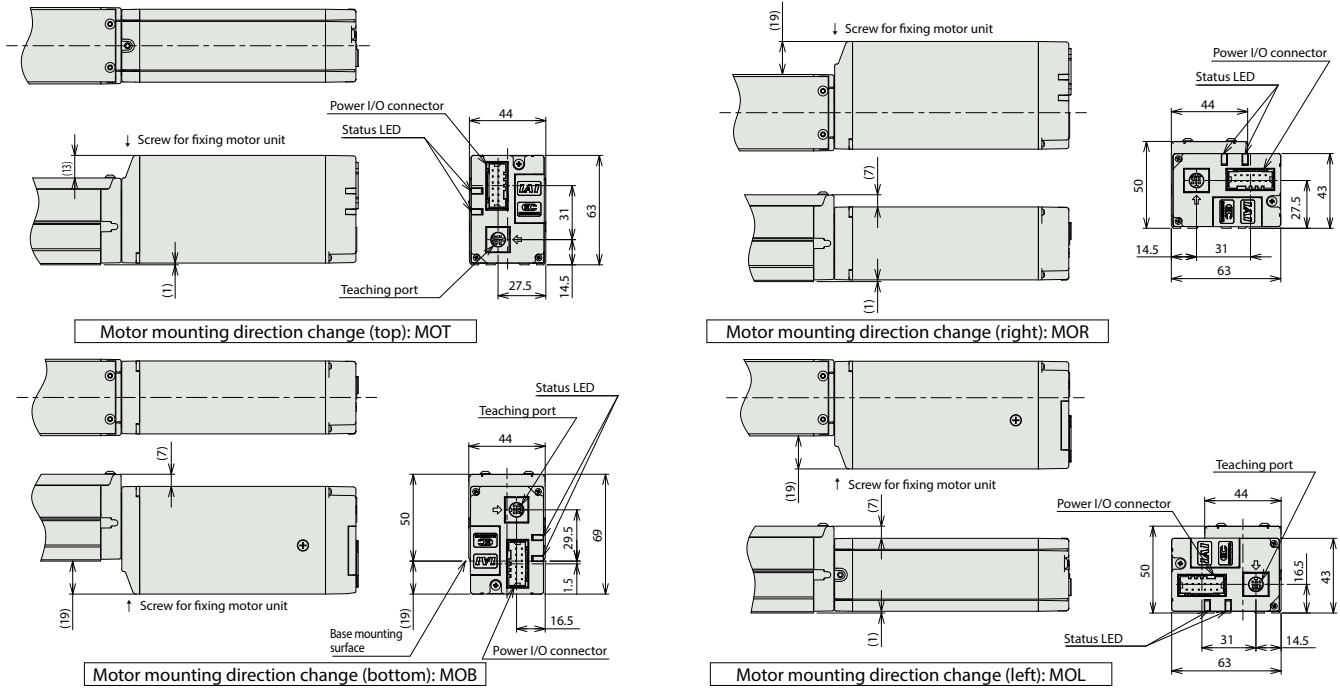

Dimensions by stroke

Stroke		50	100	150	200	250	300	
L	Incremental	Without brake	299	349	399	449	499	549
		With brake	329	379	429	479	529	579
	Battery-less absolute	Without brake	314	364	414	464	514	564
		With brake	344	394	444	494	544	594
A		164	214	264	314	364	414	
B		134	184	234	284	334	384	
J		100	150	200	250	300	350	

Mass by stroke

Stroke		50	100	150	200	250	300
Weight (kg)	Without brake	1.3	1.5	1.7	1.9	2.1	2.3
	With brake	1.5	1.7	1.9	2.1	2.2	2.4

Applicable controller

(Note) The EC series is equipped with a built-in controller. Please refer to P116 for details.

EC-RR6



Model Specification Items

EC	—	RR6	—		—		—		—	
Series	—	Type	—	Lead	—	Stroke	—	Cable Length	—	Options
		S		20mm		65		65mm		Options Refer to Options below.
		H		12mm		1		1		
		M		6mm		315		315mm (per 50mm)		
		L		3mm						
		0		With terminal block type connector						
		1		1m						
		1		1						
		10		10m						



Radial load specification
Radial Cylinder*

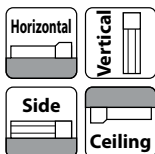

- (1) The actuator specifications display the payload's maximum value, but it will vary depending on the acceleration and speed. Please refer to "Table of Payload by Speed/Acceleration" for more details.
- (2) The Radial Cylinder is equipped with a guide. Please refer to P111 for details of the radial loads applied to the rod.
- (3) The value of the horizontal payload assumes the use of an external guide.
- (4) When performing a push-motion operation, please refer to the "Correlation between push force and current limit value." Push force is only a guide.
- (5) Depending on the ambient operating temperature, duty control is necessary. Please refer to P115 for cautions.
- (6) Special attention needs to be paid to the mounting orientation. Please refer to P33 for details.

Options

Name	Option code	Reference page
Brake	B	See P.101
Tip adapter (flange)	FFA	See P.101
Flange (front)	FL	See P.102
Foot bracket	FT	See P.103
Tip adapter (female screw)	NFA	See P.106
Knuckle joint (Note 1)	NJ	See P.107
Knuckle joint + oscillation receiving bracket (Note 1)	NJPB	See P.107
Non-motor end specification	NM	See P.108
PNP specification	PN	See P.108
Clevis bracket (Note 1)	QR	See P.108
Clevis bracket + oscillation receiving bracket (Note 1)	QRPB	See P.109
Split motor and controller power supply specification	TMD2	See P.109
Battery-less absolute encoder	WA	See P.109
Wireless communication specification	WL	See P.109
Wireless axis-operation specification	WL2	See P.109

(Note 1) Please purchase a clevis bracket (QR or QRPB) and a knuckle joint (NJ or NJPB) together as a set. Mounting is to be done by customer.

Stroke

Stroke (mm)	EC-RR6	Stroke (mm)	EC-RR6
65	○	215	○
115	○	265	○
165	○	315	○

Cable Length

Cable code	Cable length
0	No cable (with connector)
1 ~ 3	1 ~ 3m
4 ~ 5	4 ~ 5m
6 ~ 10	6 ~ 10m

(Note) Robot cables.

Main specifications

Item		Description			
Lead	Ball screw lead (mm)	20	12	6	3
	Max. payload (kg) (energy-saving disabled)	6	25	40	60
	Max. payload (kg) (energy-saving enabled)	6	25	40	40
Horizontal	Max. speed (mm/s)	800	700	450	225
	Min. speed (mm/s)	25	15	8	4
	Rated acceleration/deceleration (G)	0.3	0.3	0.3	0.3
	Max. acceleration/deceleration (G)	1	1	1	1
	Max. payload (kg) (energy-saving disabled)	1.5	4	10	12.5
Vertical	Max. payload (kg) (energy-saving enabled)	1	4	10	12.5
	Max. speed (mm/s)	800	700	450	225
	Min. speed (mm/s)	25	15	8	4
	Rated acceleration/deceleration (G)	0.3	0.3	0.3	0.3
	Max. acceleration/deceleration (G)	0.5	0.5	0.5	0.5
Push force	Max. thrust force when pushing (N)*	67	112	224	449
	Max. speed when pushing (mm/s)	20	20	20	20
Brake	Brake specification	Non-excitation actuating solenoid brake			
	Brake holding force (kgf)	1.5	4	10	12.5
Stroke	Min. stroke (mm)	65	65	65	65
	Max. stroke (mm)	315	315	315	315
	Stroke pitch (mm)	50	50	50	50

Item	Description
Driving system	Ball screw ϕ 10mm, Rolling C10
Positioning repeatability	\pm 0.05mm
Lost motion	-
Linear guide	Linear motion infinite circulating type
Rod	ϕ 25mm Material: Aluminum Hard alumite treatment
Rod no-rotation precision (Note 2)	0 degree
Ambient operation temperature/humidity	0~40°C, 85%RH or less (Non-condensing)
Degree of protection	IP20
Vibration & shock resistance	4.9m/s ² 100Hz or less
Overseas standards	CE Marking, RoHS (Restriction of Hazardous Substances)
Motor type	Stepper motor
Encoder type	Incremental / battery-less absolute
Number of encoder pulses	800 pulse/rev

(Note 2) The rod tip displacement angle when no load is applied.

* Speed limitation applies to push motion. See the manual or contact IAI.

Table of Payload by Speed/Acceleration

Setting for energy-saving disabled Unit for payload is kg. Operations on the blank locations are not possible.

Lead 20

Orientation	Acceleration (G)					
	Horizontal		Vertical			
Speed (mm/s)	0.3	0.5	0.7	1	0.3	0.5
0	6	6	5	5	1.5	1.5
160	6	6	5	5	1.5	1.5
320	6	6	5	3	1.5	1.5
480	6	6	5	3	1.5	1.5
640	6	4	3	2	1.5	1.5
800	4	3			1	1

Lead 12

Orientation	Acceleration (G)					
	Horizontal		Vertical			
Speed (mm/s)	0.3	0.5	0.7	1	0.3	0.5
0	25	18	16	12	4	4
100	25	18	16	12	4	4
200	25	18	16	10	4	4
400	20	14	10	6	4	4
500	15	8	6	4	3.5	3
700	6	2			2	1

Lead 6

Orientation	Acceleration (G)					
	Horizontal		Vertical			
Speed (mm/s)	0.3	0.5	0.7	1	0.3	0.5
0	40	35	30	25	10	10
50	40	35	30	25	10	10
100	40	35	30	25	10	10
200	40	30	25	20	10	10
250	40	27.5	22.5	18	9	8
350	30	14	12	10	5	5
400	18	10	6	5	3	3
450	8	3			2	1

Lead 3

Orientation	Acceleration (G)					
	Horizontal		Vertical			
Speed (mm/s)	0.3	0.5	0.7	1	0.3	0.5
0	60	50	45	40	12.5	12.5
50	60	50	45	40	12.5	12.5
100	60	50	45	40	12.5	12.5
125	60	50	40	30	10	10
175	40	35	25	20	6	5
200	35	30	20	14	5	4.5
225	16	16	10	6	5	4

■ **Setting for energy-saving enabled** Unit for payload is kg. Operations on the blank locations are not possible

Lead 20

Orientation	Horizontal			Vertical		
	Acceleration (G)			Acceleration (G)		
Speed (mm/s)	0.3	0.7	0.3	0.3	0.7	0.3
0	6	5	1			
160	6	5	1			
320	6	5	1			
480	4	3	1			
640	3	1	0.5			

Lead 12

Orientation	Horizontal						Vertical					
	Acceleration (G)						Acceleration (G)					
Speed (mm/s)	0.3	0.5	0.7	1	0.3	0.5	0.3	0.5	0.7	1	0.3	0.5
0	25	10	4	30	8	8						
100	25	10	4	30	8	8						
200	25	10	4	20	7	7						
300	20	8	3	10	4.5	4						
400	10	5	2	2	2	1						
500	5	2	1									

Lead 6

Orientation	Horizontal					Vertical				
	Acceleration (G)					Acceleration (G)				
Speed (mm/s)	0.3	0.5	0.7	1	0.3	0.5	0.7	1	0.3	0.5
0	40	20	10	40	18	18				
50	40	20	10	40	18	18				
100	40	20	10	40	16	12				
150	40	20	8	26	10	9				
200	35	18	5	11	5	4				
250	10	6	3		2	1				

Lead 3

Orientation	Horizontal						Vertical					
	Acceleration (G)						Acceleration (G)					
Speed (mm/s)	0.3	0.5	0.7	1	0.3	0.5	0.3	0.5	0.7	1	0.3	0.5
0	40	25	12.5	40	18	18						
25	40	25	12.5	40	18	18						
50	40	25	12.5	40	16	12						
75	40	25	12	26	10	9						
100	40	25	9	11	5	4						
125	40	25	5	2	1							

Stroke and maximum speed

Lead (mm)	Energy-saving mode	65-215 (per 50mm)	265 (mm)	315 (mm)
20	Disabled		800	
	Enabled		640	
12	Disabled	700	660	480
	Enabled	500		480
6	Disabled	450	325	235
	Enabled	250		235
3	Disabled	225	160	115
	Enabled	125		115

(Unit is mm/s)

Correlation between push force and current limit value

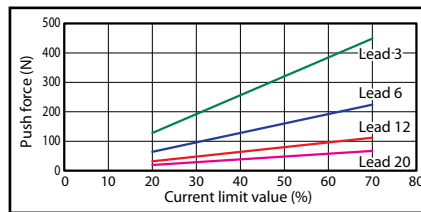

Rod deflection (reference value)

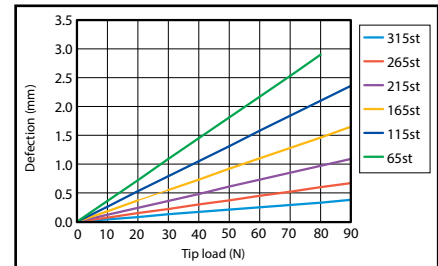

Dimensions

*1 When the rod is returning to its home position, please be careful of interference from surrounding objects, as it will travel until it reaches the M.E.
 *2 The direction of width across flats varies depending on the product. Those flats cannot be used for reference plane.
 (Note) The EC series is equipped with a built-in controller. Please refer to P111 for details.

CAD drawings can be downloaded from our website.
www.intelligentactuator.com

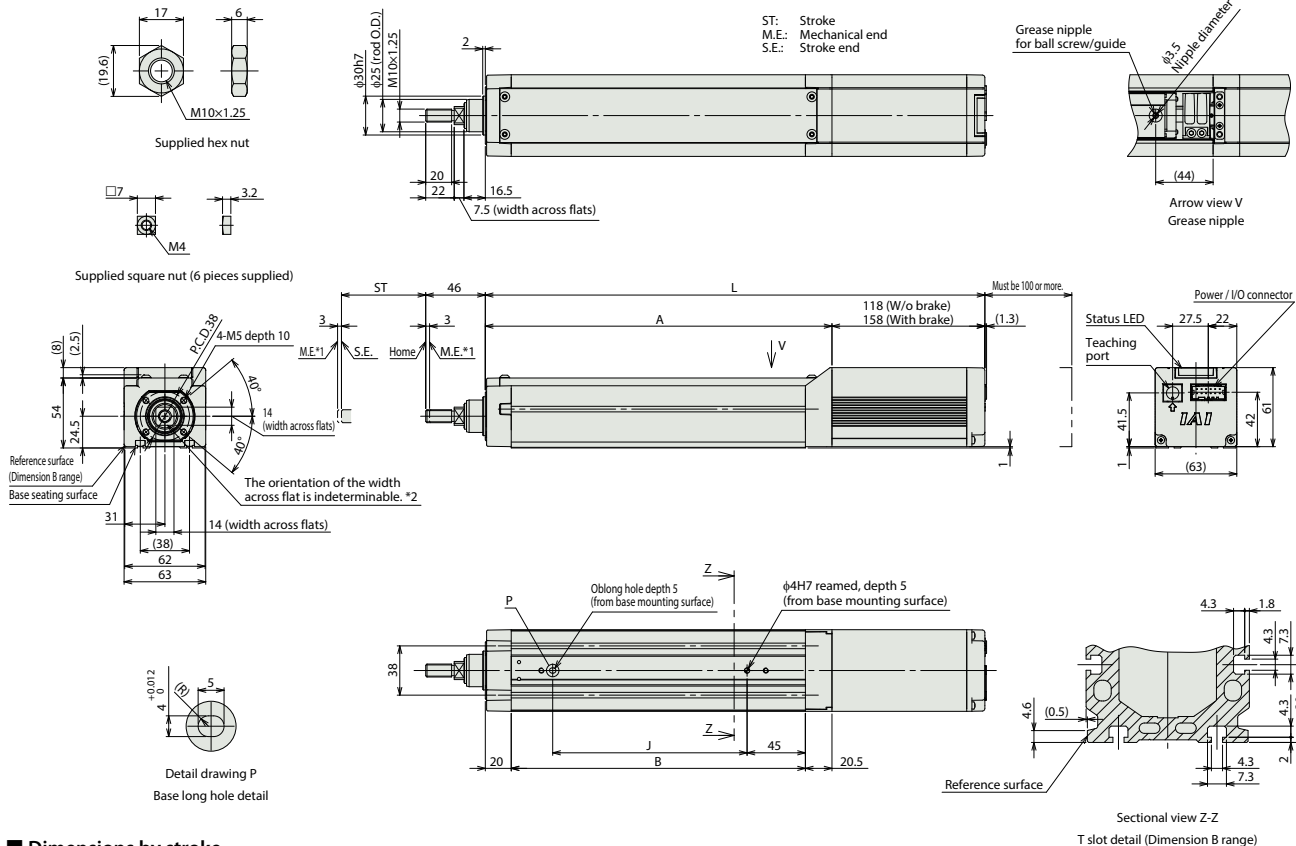

■ **Dimensions by stroke**

L	Stroke	65	115	165	215	265	315
	W/o Brake	335.5	385.5	435.5	485.5	535.5	585.5
With Brake	375.5	425.5	475.5	525.5	575.5	625.5	
A	217.5	267.5	317.5	367.5	417.5	467.5	
B	177	227	277	327	377	427	
J	100	150	200	250	300	350	

■ **Mass by stroke**

Mass (kg)	Stroke	65	115	165	215	265	315
	Without brake	1.7	2.0	2.2	2.5	2.7	3.0
With brake	1.9	2.2	2.4	2.7	3.0	3.2	

Applicable controller

(Note) The EC series is equipped with a built-in controller. Please refer to P116 for details.

EC-RR7



Model Specification Items

EC	—	RR7	—	—	—	—	—	—
Series	—	Type	Lead	—	Stroke	—	Cable Length	Options
		S	24mm		65	65mm	0	With terminal block type connector
		H	16mm		1	1	1	1m
		M	8mm		315	315mm (per 50mm)	1	1
		L	4mm				10	10m
								Refer to Options below.

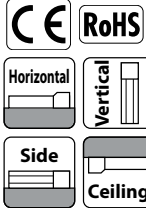

Radial load specification
Radial Cylinder*



- (1) The actuator specifications display the payload's maximum value, but it will vary depending on the acceleration and speed. Please refer to "Table of Payload by Speed/Acceleration" for more details.
- (2) The Radial Cylinder is equipped with a guide. Please refer to P111 for details of the radial loads applied to the rod.
- (3) The value of the horizontal payload assumes the use of an external guide.
- (4) When performing a push-motion operation, please refer to the "Correlation between push force and current limit value." Push force is only a guide.
- (5) Depending on the ambient operating temperature, duty control is necessary. Please refer to P115 for cautions.
- (6) Special attention needs to be paid to the mounting orientation. Please refer to P33 for details.

Stroke

Stroke (mm)	EC-RR7	Stroke (mm)	EC-RR7
65	○	215	○
115	○	265	○
165	○	315	○

Cable Length

Cable code	Cable length
0	No cable (with connector)
1 ~ 3	1 ~ 3m
4 ~ 5	4 ~ 5m
6 ~ 10	6 ~ 10m

(Note) Robot cables.

Options

Name	Option code	Reference page
Brake	B	See P101
Tip adapter (flange)	FFA	See P101
Flange (front)	FL	See P102
Foot bracket	FT	See P103
Tip adapter (female screw)	NFA	See P106
Knuckle joint (Note 1)	NJ	See P107
Knuckle joint + oscillation receiving bracket (Note 1)	NJPB	See P107
Non-motor end specification	NM	See P108
PNP specification	PN	See P108
Clevis bracket (Note 1)	QR	See P108
Clevis bracket + oscillation receiving bracket (Note 1)	QRPB	See P109
Split motor and controller power supply specification	TMD2	See P109
Battery-less absolute encoder	WA	See P109
Wireless communication specification	WL	See P109
Wireless axis-operation specification	WL2	See P109

(Note 1) Please purchase a clevis bracket (QR or QRPB) and a knuckle joint (NJ or NJPB) together as a set. Mounting is to be done by customer.

Main specifications

Item		Description				
Lead	Ball screw lead (mm)	24	16	8	4	
	Payload	Max. payload (kg) (energy-saving disabled)	20	50	60	80
		Max. payload (kg) (energy-saving enabled)	18	40	50	55
		Max. speed (mm/s)	860	700	350	175
Horizontal	Min. speed (mm/s)	30	20	10	5	
	Speed/acceleration/deceleration	Rated acceleration/deceleration (G)	0.3	0.3	0.3	0.3
		Max. acceleration/deceleration (G)	1	1	1	1
		Max. accleration/deceleration (G)	0.5	0.5	0.5	0.5
Vertical	Payload	Max. payload (kg) (energy-saving disabled)	3	8	18	19
		Max. payload (kg) (energy-saving enabled)	3	5	17.5	19
	Speed/acceleration/deceleration	Max. speed (mm/s)	640	560	350	175
Push force	Min. speed (mm/s)	30	20	10	5	
	Rated acceleration/deceleration (G)	0.3	0.3	0.3	0.3	
	Max. accleration/deceleration (G)	0.5	0.5	0.5	0.5	
Brake	Pushing max. thrust force (N)*	182	273	547	1094	
	Pushing max. speed (mm/s)	20	20	20	20	
Stroke	Brake holding specification	Non-excitation actuating solenoid brake				
	Brake holding force (kgf)	3	8	18	19	
Stroke	Min. stroke (mm)	65	65	65	65	
	Max. stroke (mm)	315	315	315	315	
	Stroke pitch (mm)	50	50	50	50	

Item	Description
Driving system	Ball screw φ12mm, Rolling C10
Positioning repeatability	±0.05mm
Lost motion	-
Linear guide	Linear motion infinite circulating type
Rod	φ30mm Material: Aluminum Hard alumite treatment
Rod non-rotation accuracy (Note 2)	0 degree
Ambient operation temperature/humidity	0~40°C, 85%RH or less (Non-condensing)
Degree of protection	IP20
Vibration & shock resistance	4.9m/s ² 100Hz or less
Overseas standards	CE marking, RoHS (Restriction of Hazardous Substances)
Motor type	Stepper motor
Encoder type	Incremental / battery-less absolute
Number of encoder pulses	800 pulse/rev

(Note 2) The rod tip displacement angle when no load is applied.

* Speed limitation applies to push motion. See the manual or contact IAI.

Table of Payload by Speed/Acceleration

Setting for energy-saving disabled Unit for payload is kg. Operations on the blank locations are not possible.

Lead 24

Orientation	Speed (mm/s)	Acceleration (G)						
		0.3	0.5	0.7	1	0.3	0.5	
Horizontal	0	20	18	15	12	3	3	
	200	20	18	15	12	3	3	
	400	20	14	12	8	3	3	
	420	17	12	10	6	3	3	
	600	14	6	5	4	3	2	
	640	5	3	2	1.5	2	1	
	800	5	1	1				
	860	2	0.5					
	Vertical	0	80	70	65	60	19	19
		35	80	70	65	60	19	19
70		80	70	65	60	19	19	
105		80	60	50	40	18	18	
140		50	30	20	15	12	10	
175		15						

Lead 16

Orientation	Speed (mm/s)	Acceleration (G)						
		0.3	0.5	0.7	1	0.3	0.5	
Horizontal	0	50	40	35	30	8	8	
	140	50	40	35	30	8	8	
	280	50	35	25	20	7	7	
	420	25	18	14	10	4.5	4	
	560	10	5	3	2	2	1	
	700	2						
	Vertical	0	80	70	65	60	19	19
		35	80	70	65	60	19	19
		70	80	70	65	60	19	19
		105	80	60	50	40	18	18
140		50	30	20	15	12	10	
175		15						

Lead 8

Orientation	Speed (mm/s)	Acceleration (G)						
		0.3	0.5	0.7	1	0.3	0.5	
Horizontal	0	60	50	45	40	18	18	
	70	60	50	45	40	18	18	
	140	60	50	45	40	16	12	
	210	60	40	31	26	10	9	
	280	34	20	15	11	5	4	
	350	12	4	1				
	Vertical	0	80	70	65	60	19	19
		35	80	70	65	60	19	19
		70	80	70	65	60	19	19
		105	80	60	50	40	18	18
140		50	30	20	15	12	10	
175		15						

■ Setting for energy-saving enabled Unit for payload is kg. Operations on the blank locations are not possible

Lead 24

Orientation	Acceleration (G)		
	0.3	0.7	0.3
Speed (mm/s)			
0	18	9.5	3
200	18	9.5	3
420	10	5	1.5
600	1		

Lead 16

Orientation	Acceleration (G)		
	0.3	0.7	0.3
Speed (mm/s)			
0	40	25	5
140	40	25	5
280	18	12	2
420	1.5	1	

Lead 8

Orientation	Acceleration (G)		
	0.3	0.7	0.3
Speed (mm/s)			
0	50	30	17.5
70	50	30	17.5
140	50	30	7
210	14	7	2

Lead 4

Orientation	Acceleration (G)		
	0.3	0.7	0.3
Speed (mm/s)			
0	55	50	19
35	55	50	19
70	55	50	13
105	30	15	2

Stroke and maximum speed

Lead (mm)	Energy-saving mode	65-215 (per 50mm)	265 (mm)	315 (mm)
24	Disabled	860<640>		
	Enabled	600<420>		
16	Disabled	700<560>		
	Enabled	420<280>		
8	Disabled	350		
	Enabled	210		
4	Disabled	175		
	Enabled	105		

(Note) Figures in <> represent vertical operations. (Unit is mm/s)

Correlation between push force and current limit value

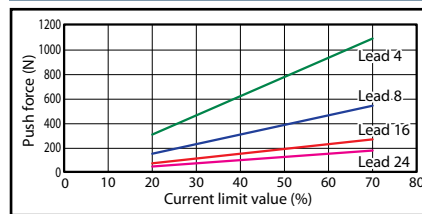

Rod deflection (reference value)

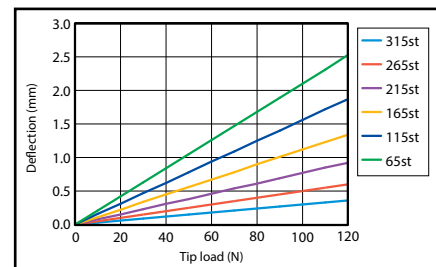

Dimensions

*1 When the rod is returning to its home position, please be careful of interference from surrounding objects, as it will travel until it reaches the M.E.
*2 The direction of width across flats varies depending on the product. Those flats cannot be used for reference plane.

CAD drawings can be downloaded from our website.
www.intelligentactuator.com

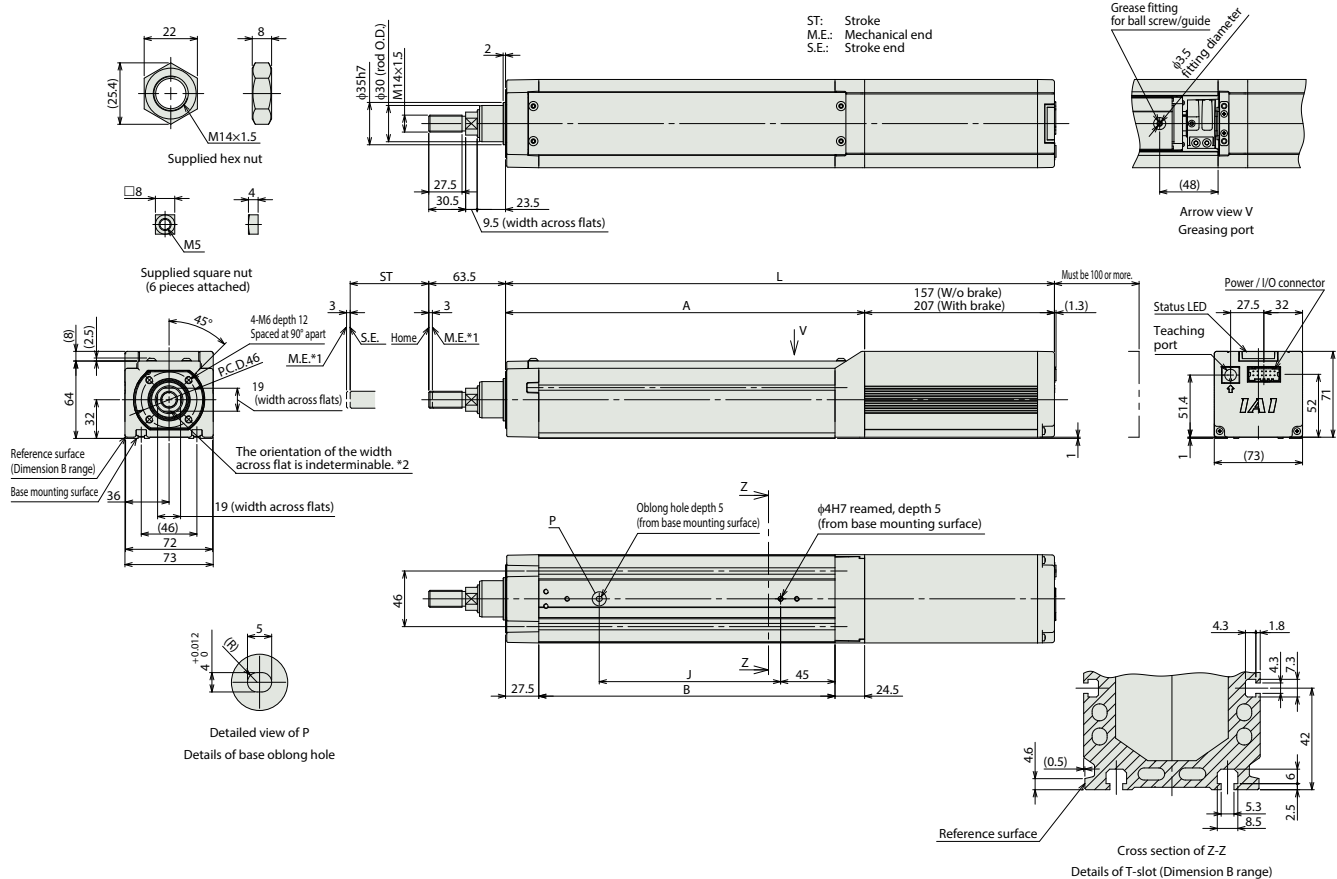

■ Dimensions by stroke

Stroke	Stroke						
	65	115	165	215	265	315	
L	W/o Brake	404	454	504	554	604	654
	With Brake	454	504	554	604	654	704
A	247	297	347	397	447	497	
B	195	245	295	345	395	445	
J	100	150	200	250	300	350	

■ Mass by stroke

Mass (kg)	Stroke					
	65	115	165	215	265	315
Without brake	3.7	4.1	4.4	4.8	5.2	5.5
	With brake	4.3	4.6	5.0	5.3	5.7

Applicable controller

(Note) The EC series is equipped with a built-in controller. Please refer to P116 for details.

EC-RR6□AH

High Rigidity

Coupled Motor

Body width
63 mm

24v
Stepper motor

Model Specification Items

EC	RR6		AH			
Series	Type	Lead	Specification	Stroke	Cable Length	Options
		S 20mm H 12mm M 6mm L 3mm	AH High Rigidity	50 100 150 200 400	50mm 100mm 150mm 200mm 400mm (per 50mm)	0 1 2 3 4 5 6 7 8 9 10
					With terminal block type connector	Refer to Options below.

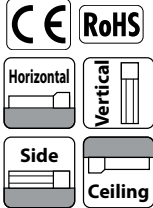

Radial load specification Radial Cylinder*



- (1) The actuator specifications display the payload's maximum value, but it will vary depending on the acceleration and speed. Please refer to "Table of Payload by Speed/Acceleration" for more details.
- (2) The Radial Cylinder is equipped with a guide. Please refer to P111 for details of the radial loads applied to the rod.
- (3) The value of the horizontal payload assumes the use of an external guide.
- (4) When performing a push-motion operation, please refer to the "Correlation between push force and current limit value." Push force is only a guide.
- (5) Depending on the ambient operating temperature, duty control is necessary. Please refer to P115 for cautions.
- (6) Special attention needs to be paid to the mounting orientation. Please refer to P33 for details.

Options

Name	Option code	Reference page
Brake	B	See P.101
Tip adapter (flange)	FFA	See P.101
Flange (front)	FL	See P.102
Tip adapter (female screw)	NFA	See P.103
Knuckle joint (Note 1)	NJ	See P.106
Knuckle joint + oscillation receiving bracket (Note 1)	NJPB	See P.107
Non-motor end specification	NM	See P.107
PNP specification	PN	See P.108
Clevis bracket (Note 1)	QR	See P.108
Clevis bracket + oscillation receiving bracket (Note 1)	QRPB	See P.108
Split motor and controller power supply specification	TMD2	See P.109
Battery-less absolute encoder	WA	See P.109
Wireless communication specification	WL	See P.109
Wireless axis-operation specification	WL2	See P.109

(Note 1) Please purchase a clevis bracket (QR or QRPB) and a knuckle joint (NJ or NJPB) together as a set. Mounting is to be done by customer.

Stroke

Stroke (mm)	EC-RR6□AH	Stroke (mm)	EC-RR6□AH
50	○	250	○
100	○	300	○
150	○	350	○
200	○	400	○

Cable Length

Cable code	Cable length
0	No cable (with connector)
1 ~ 3	1 ~ 3m
4 ~ 5	4 ~ 5m
6 ~ 10	6 ~ 10m

(Note) Robot cables.

Main specifications

Item		Description				
Lead	Ball screw lead (mm)	20	12	6	3	
	Payload	Max. payload (kg) (energy-saving disabled)	6	25	40	60
		Max. payload (kg) (energy-saving enabled)	6	25	40	40
	Horizontal	Speed/acceleration/deceleration	Max. speed (mm/s)	800	700	450
Min. speed (mm/s)		25	15	8	4	
Rated acceleration/deceleration (G)		0.3	0.3	0.3	0.3	
Max. acceleration/deceleration (G)		1	1	1	1	
Vertical	Payload	Max. payload (kg) (energy-saving disabled)	1.5	4	10	20
	Max. payload (kg) (energy-saving enabled)	1	4	10	20	
Speed/acceleration/deceleration	Max. speed (mm/s)	800	700	450	225	
	Min. speed (mm/s)	25	15	8	4	
	Rated acceleration/deceleration (G)	0.3	0.3	0.3	0.3	
	Max. acceleration/deceleration (G)	0.5	0.5	0.5	0.5	
Push force	Pushing max. thrust force (N)*	67	112	224	449	
	Pushing max. speed (mm/s)	20	20	20	20	
Brake	Brake holding specification	Non-excitation actuating solenoid brake				
	Brake holding force (kgf)	1.5	4	10	20	
Stroke	Min. stroke (mm)	50	50	50	50	
	Max. stroke (mm)	400	400	400	400	
	Stroke pitch (mm)	50	50	50	50	

Item	Description
Driving system	Ball screw φ10mm, Rolling C10
Positioning repeatability	±0.05mm
Lost motion	-
Linear guide	Linear motion infinite circulating type
Rod	φ25mm Material: Aluminum Hard alumite treatment
Rod non-rotation accuracy (Note 2)	0 degree
Ambient operation temperature/humidity	0~40°C, 85%RH or less (Non-condensing)
Degree of protection	IP20
Vibration & shock resistance	4.9m/s ² 100Hz or less
Overseas standards	CE marking, RoHS (Restriction of Hazardous Substances)
Motor type	Stepper motor
Encoder type	Incremental / battery-less absolute
Number of encoder pulses	800 pulse/rev

(Note 2) The rod tip displacement angle when no load is applied.

* Speed limitation applies to push motion. See the manual or contact IAI.

Table of Payload by Speed/Acceleration

Setting for energy-saving disabled Unit for payload is kg. Operations on the blank locations are not possible.

Lead 20

Orientation	Horizontal					Vertical				
	Acceleration (G)					Acceleration (G)				
Speed (mm/s)	0.3	0.5	0.7	1	0.3	0.5	0.7	1	0.3	0.5
0	6	6	5	5	1.5	1.5				
160	6	6	5	5	1.5	1.5				
320	6	6	5	3	1.5	1.5				
480	6	6	5	3	1.5	1.5				
640	6	4	3	2	1.5	1.5				
800	4	3			1	1				

Lead 12

Orientation	Horizontal					Vertical				
	Acceleration (G)					Acceleration (G)				
Speed (mm/s)	0.3	0.5	0.7	1	0.3	0.5	0.7	1	0.3	0.5
0	25	18	16	12	4	4				
100	25	18	16	12	4	4				
200	25	18	16	10	4	4				
400	20	14	10	6	4	4				
500	15	8	6	4	3.5	3				
700	6	2			2	1				

Lead 6

Orientation	Horizontal					Vertical				
	Acceleration (G)					Acceleration (G)				
Speed (mm/s)	0.3	0.5	0.7	1	0.3	0.5	0.7	1	0.3	0.5
0	40	35	30	25	10	10				
50	40	35	30	25	10	10				
100	40	35	30	25	10	10				
200	40	30	25	20	10	10				
250	40	27.5	22.5	18	9	8				
350	30	14	12	10	5	5				
400	18	10	6	5	3	3				
450	8	3			2	1				

Lead 3

Orientation	Horizontal					Vertical				
	Acceleration (G)					Acceleration (G)				
Speed (mm/s)	0.3	0.5	0.7	1	0.3	0.5	0.7	1	0.3	0.5
0	60	50	45	40	20	20				
50	60	50	45	40	20	20				
100	60	50	45	40	20	20				
125	60	50	40	30	10	10				
175	40	35	25	20	6	5				
200	35	30	20	14	5	4.5				
225	16	16	10	6	5	4				

■ Setting for energy-saving enabled Unit for payload is kg. Operations on the blank locations are not possible

Lead 20

Orientation	Horizontal			Vertical
	Acceleration (G)			
Speed (mm/s)	0.3	0.7	0.3	
0	6	5	1	
160	6	5	1	
320	6	5	1	
480	4	3	1	
640	3	1	0.5	

Lead 12

Orientation	Horizontal			Vertical
	Acceleration (G)			
Speed (mm/s)	0.3	0.7	0.3	
0	25	10	4	
100	25	10	4	
200	25	10	4	
300	20	8	3	
400	10	5	2	
500	5	2	1	

Lead 6

Orientation	Horizontal			Vertical
	Acceleration (G)			
Speed (mm/s)	0.3	0.7	0.3	
0	40	20	10	
50	40	20	10	
100	40	20	10	
150	40	20	8	
200	35	18	5	
250	10	6	3	

Lead 3

Orientation	Horizontal			Vertical
	Acceleration (G)			
Speed (mm/s)	0.3	0.7	0.3	
0	40	25	20	
25	40	25	20	
50	40	25	20	
75	40	25	12	
100	40	25	9	
125	40	25	5	

Stroke and maximum speed

Lead (mm)	Energy-saving mode	50-400 (per 50mm)
20	Disabled	800
	Enabled	640
12	Disabled	700
	Enabled	500
6	Disabled	450
	Enabled	250
3	Disabled	225
	Enabled	125

(Unit is mm/s)

Correlation between push force and current limit value

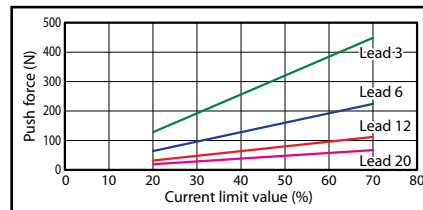

Rod deflection (reference value)

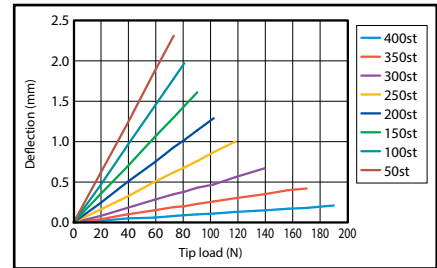

Dimensions

*1 When the rod is returning to its home position, please be careful of interference from surrounding objects, as it will travel until it reaches the M.E.
*2 The direction of width across flats varies depending on the product. Those flats cannot be used for reference plane.

CAD drawings can be downloaded from our website.
www.intelligentactuator.com

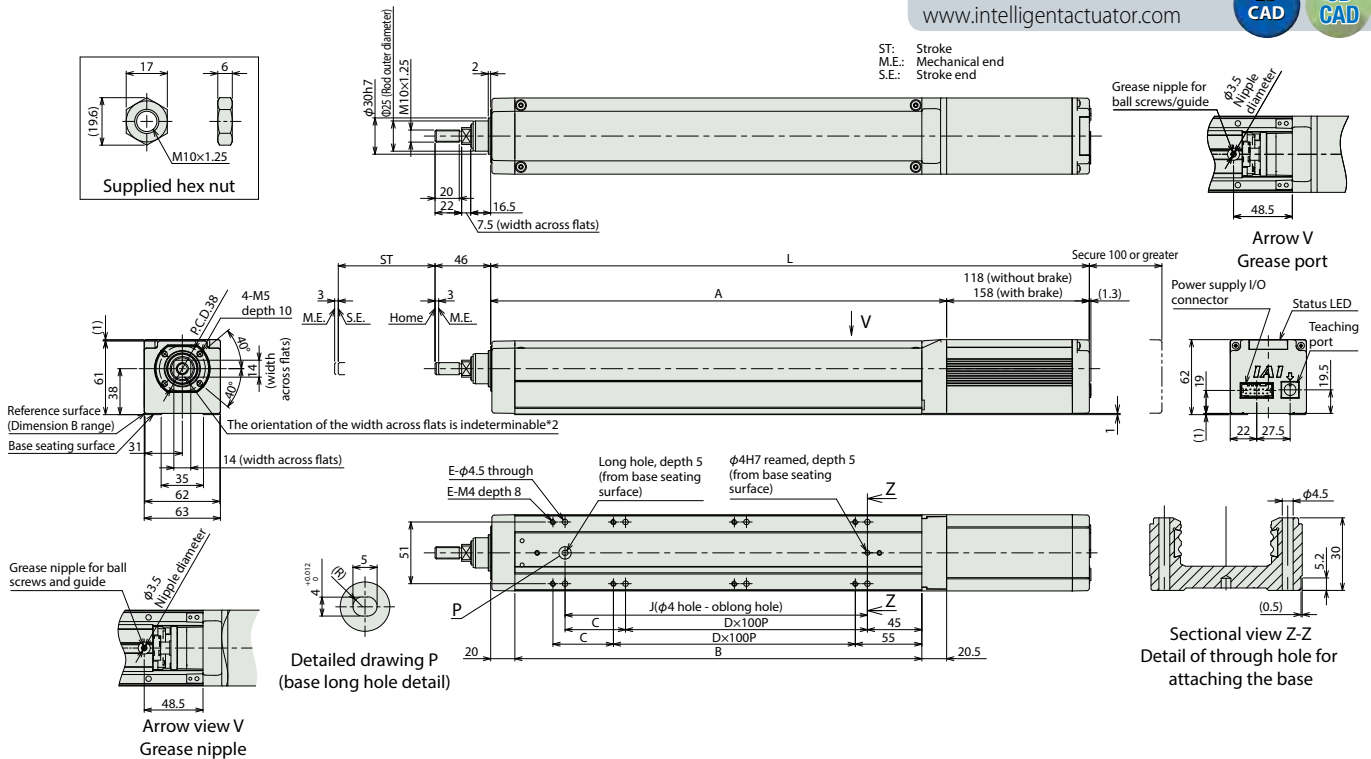

■ Dimensions by stroke

L	Stroke	50	100	150	200	250	300	350	400
	W/o Brake	345	395	445	495	545	595	645	695
With Brake	385	435	485	535	585	635	685	735	
A	227	277	327	377	427	477	527	577	
B	186.5	236.5	286.5	336.5	386.5	436.5	486.5	536.5	
C	0	50	0	50	0	50	0	50	
D	1	1	2	2	3	3	4	4	
E	4	6	6	8	8	10	10	12	
J	100	150	200	250	300	350	400	450	

■ Mass by stroke

Weight (kg)	Stroke	50	100	150	200	250	300	350	400
	W/o Brake	2	2.2	2.5	2.8	3	3.3	3.6	3.8
With Brake	2.3	2.5	2.8	3.1	3.3	3.6	3.9	4.1	

Applicable controller

The EC series is equipped with a controller built-in. Please refer to P116 for details.

EC-RR7□AH

High Rigidity

Coupled Motor

Body width 75 mm

24v Stepper motor

Model Specification Items

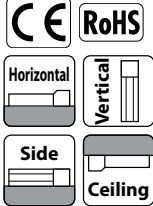
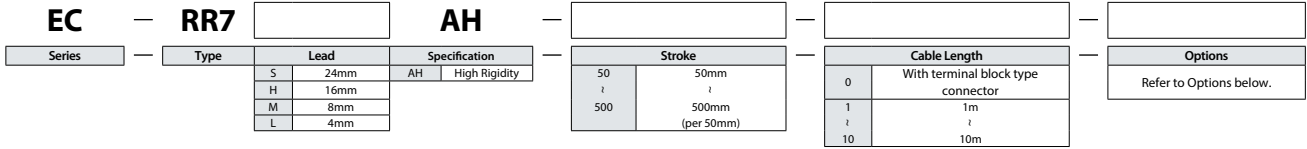

Radial load specification
Radial Cylinder*



- POINT Selection Notes**
- (1) The actuator specifications display the payload's maximum value, but it will vary depending on the acceleration and speed. Please refer to "Table of Payload by Speed/Acceleration" for more details.
 - (2) The Radial Cylinder is equipped with a guide. Please refer to P111 for details of the radial loads applied to the rod.
 - (3) The value of the horizontal payload assumes the use of an external guide.
 - (4) When performing a push-motion operation, please refer to the "Correlation between push force and current limit value." Push force is only a guide.
 - (5) Depending on the ambient operating temperature, duty control is necessary. Please refer to P115 for cautions.
 - (6) Special attention needs to be paid to the mounting orientation. Please refer to P33 for details.

Stroke

Stroke (mm)	EC-RR7□AH	Stroke (mm)	EC-RR7□AH
50	○	300	○
100	○	350	○
150	○	400	○
200	○	450	○
250	○	500	○

Cable Length

Cable code	Cable length
0	No cable (with connector)
1 ~ 3	1 ~ 3m
4 ~ 5	4 ~ 5m
6 ~ 10	6 ~ 10m

(Note) Robot cables.

Options

Name	Option code	Reference page
Brake	B	See P.101
Tip adapter (flange)	FFA	See P.101
Flange (front)	FL	See P.102
Tip adapter (female screw)	NFA	See P.103
Knuckle joint (Note 1)	NJ	See P.106
Knuckle joint + oscillation receiving bracket (Note 1)	NJPB	See P.107
Non-motor end specification	NM	See P.108
PNP specification	PN	See P.108
Clevis bracket (Note 1)	QR	See P.108
Clevis bracket + oscillation receiving bracket (Note 1)	QRPB	See P.109
Split motor and controller power supply specification	TMD2	See P.109
Battery-less absolute encoder	WA	See P.109
Wireless communication specification	WL	See P.109
Wireless axis-operation specification	WL2	See P.109

(Note) Please purchase a clevis bracket (QR or QRPB) and a knuckle joint (NJ or NJPB) together as a set. Mounting is to be done by customer.

Main specifications

Item		Description				
Lead	Ball screw lead (mm)	24	16	8	4	
Horizontal	Payload	Max. payload (kg) (energy-saving disabled)	20	50	60	80
		Max. payload (kg) (energy-saving enabled)	18	40	50	55
	Speed/acceleration/deceleration	Max. speed (mm/s)	860	700	350	175
		Min. speed (mm/s)	30	20	10	5
		Rated acceleration/deceleration (G)	0.3	0.3	0.3	0.3
Vertical	Payload	Max. payload (kg) (energy-saving disabled)	3	8	18	28
		Max. payload (kg) (energy-saving enabled)	3	5	17.5	26
	Speed/acceleration/deceleration	Max. speed (mm/s)	640	560	350	175
		Min. speed (mm/s)	30	20	10	5
		Rated acceleration/deceleration (G)	0.3	0.3	0.3	0.3
Push force	Max. acceleration/deceleration (G)	0.5	0.5	0.5	0.5	
	Pushing max. thrust force (N)*	182	273	547	1094	
Brake	Pushing max. speed (mm/s)	20	20	20	20	
	Brake holding specification	Non-excitation actuating solenoid brake				
Stroke	Brake holding force (kgf)	3	8	18	28	
	Min. stroke (mm)	50	50	50	50	
	Max. stroke (mm)	500	500	500	500	
	Stroke pitch (mm)	50	50	50	50	

Item	Description
Driving system	Ball screw φ12mm, Rolling C10
Positioning repeatability	±0.05mm
Lost motion	-
Linear guide	Linear motion infinite circulating type
Rod	φ30mm Material: Aluminum Hard alumite treatment
Rod non-rotation accuracy (Note 2)	0 degree
Ambient operation temperature/humidity	0~40°C, 85%RH or less (Non-condensing)
Degree of protection	IP20
Vibration & shock resistance	4.9m/s ² 100Hz or less
Overseas standards	CE marking, RoHS (Restriction of Hazardous Substances)
Motor type	Stepper motor
Encoder type	Incremental / battery-less absolute
Number of encoder pulses	800 pulse/rev

(Note 2) The rod tip displacement angle when no load is applied.

* Speed limitation applies to push motion. See the manual or contact IAI.

Table of Payload by Speed/Acceleration

Setting for energy-saving disabled Unit for payload is kg. Operations on the blank locations are not possible.

Lead 24

Orientation	Speed (mm/s)	Acceleration (G)					
		0.3	0.5	0.7	1	0.3	0.5
Horizontal	0	20	18	15	12	3	3
	200	20	18	15	12	3	3
	400	20	14	12	8	3	3
	420	17	12	10	6	3	3
	600	14	6	5	4	3	2
	640	5	3	2	1.5	2	1
Vertical	800	5	1	1			
	860	2	0.5				

Lead 16

Orientation	Speed (mm/s)	Acceleration (G)					
		0.3	0.5	0.7	1	0.3	0.5
Horizontal	0	50	40	35	30	8	8
	140	50	40	35	30	8	8
	280	50	35	25	20	7	7
	420	25	18	14	10	4.5	4
	560	10	5	3	2	2	1
	700	2					

Lead 8

Orientation	Speed (mm/s)	Acceleration (G)					
		0.3	0.5	0.7	1	0.3	0.5
Horizontal	0	60	50	45	40	18	18
	70	60	50	45	40	18	18
	140	60	50	45	40	16	12
	210	60	40	31	26	10	9
	280	34	20	15	11	5	4
	350	12	4	1		2	1

Lead 4

Orientation	Speed (mm/s)	Acceleration (G)					
		0.3	0.5	0.7	1	0.3	0.5
Horizontal	0	80	70	65	60	28	28
	35	80	70	65	60	28	28
	70	80	70	65	60	28	28
	105	80	60	50	40	18	18
	140	50	30	20	15	12	10
	175	15				2	

■ **Setting for energy-saving enabled** Unit for payload is kg. Operations on the blank locations are not possible

Lead 24

Orientation	Horizontal			Vertical
	Acceleration (G)			
Speed (mm/s)	0.3	0.7	0.3	
0	18	9.5	3	
200	18	9.5	3	
420	10	5	1.5	
630	1			

Lead 16

Orientation	Horizontal			Vertical
	Acceleration (G)			
Speed (mm/s)	0.3	0.7	0.3	
0	40	25	5	
140	40	25	5	
280	18	12	2	
420	1.5	1		

Lead 8

Orientation	Horizontal			Vertical
	Acceleration (G)			
Speed (mm/s)	0.3	0.7	0.3	
0	50	30	17.5	
70	50	30	17.5	
140	50	30	7	
210	14	7	2	

Lead 4

Orientation	Horizontal			Vertical
	Acceleration (G)			
Speed (mm/s)	0.3	0.7	0.3	
0	55	50	26	
35	55	50	26	
70	55	50	13	
105	30	15	2	

Stroke and maximum speed

Lead (mm)	Energy-saving mode	50-500 (per 50mm)
24	Disabled	860<640>
	Enabled	630<420>
16	Disabled	700<560>
	Enabled	420<280>
8	Disabled	350
	Enabled	210
4	Disabled	175
	Enabled	105

(Note) Figures in <> represent vertical operations. (Unit is mm/s)

Correlation between push force and current limit value

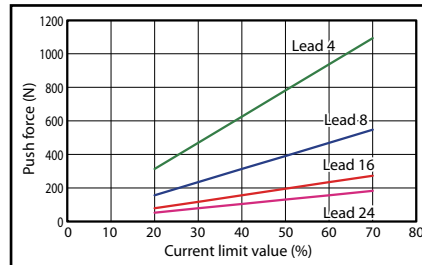

Rod deflection (reference value)

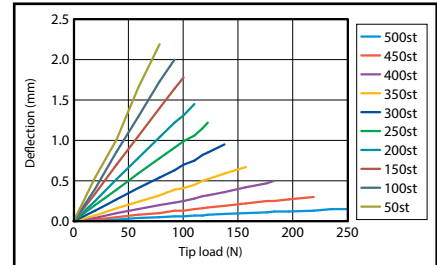

Dimensions

*1 When the rod is returning to its home position, please be careful of interference from surrounding objects, as it will travel until it reaches the M.E.
*2 The direction of width across flats varies depending on the product. Those flats cannot be used for reference plane.

CAD drawings can be downloaded from our website.
www.intelligentactuator.com

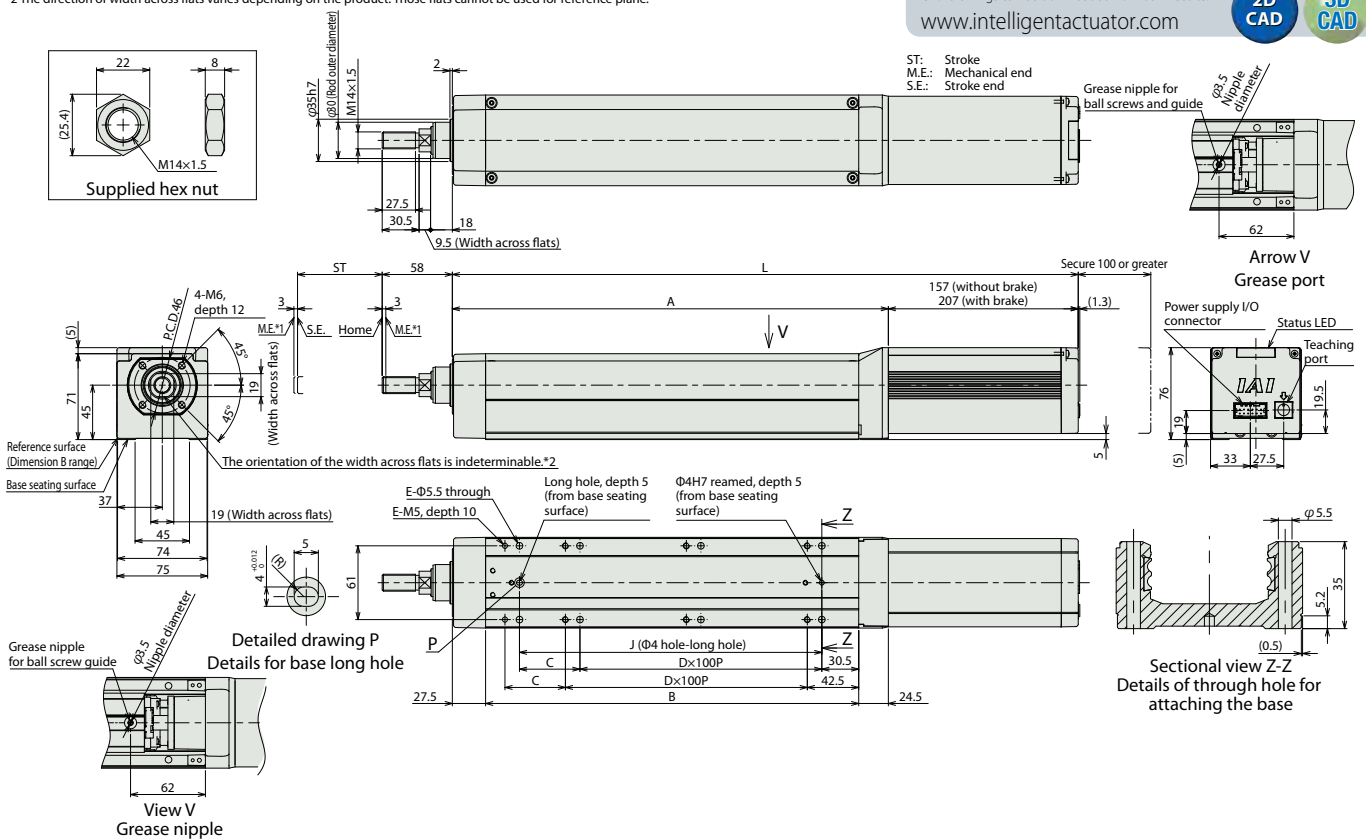

■ **Dimensions by stroke**

Stroke	50	100	150	200	250	300	350	400	450	500	
L	Without brake	417.5	467.5	517.5	567.5	617.5	667.5	717.5	767.5	817.5	867.5
	With brake	467.5	517.5	567.5	617.5	667.5	717.5	767.5	817.5	867.5	917.5
A	260.5	310.5	360.5	410.5	460.5	510.5	560.5	610.5	660.5	710.5	
B	208.5	258.5	308.5	358.5	408.5	458.5	508.5	558.5	608.5	658.5	
C	50	0	50	0	50	0	50	0	50	0	
D	1	2	2	3	3	4	4	5	5	6	
E	6	6	8	8	10	10	12	12	14	14	
J	150	200	250	300	350	400	450	500	550	600	

■ **Mass by stroke**

Stroke	50	100	150	200	250	300	350	400	450	500	
Mass (kg)	Without brake	4	4.4	4.7	5	5.4	5.7	6	6.4	6.7	7
	With brake	4.5	4.9	5.2	5.5	5.9	6.2	6.5	6.9	7.2	7.5

Applicable controller

(Note) The EC series is equipped with a controller built-in. Please refer to P116 for details.

EC-RR6□R

Side-mounted
Motor

Body width
60
mm

24v
Stepper
motor

Model Specification Items

EC — **RR6** **R**

Series	Type	Lead	Specification
S		20mm	R Motor side-mounted
H		12mm	
M		6mm	
L		3mm	

Stroke

65	65mm
115	315mm (per 50mm)
165	

Cable Length

Terminal type with connector	Cable Length
0	
1	1m
1	5m
10	10m

Options

Refer to the price list below

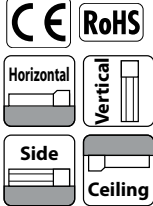

Radial load specification Radial Cylinder

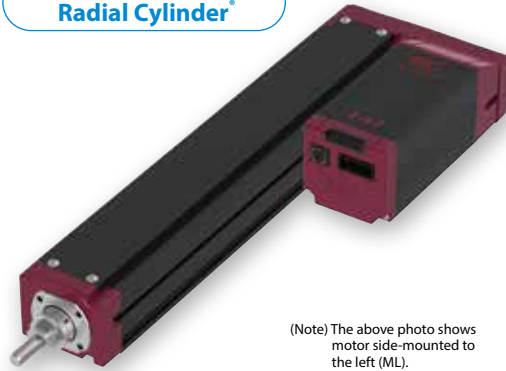

(Note) The above photo shows motor side-mounted to the left (ML).



- (1) The actuator specifications display the payload's maximum value, but it will vary depending on the acceleration and speed. Please refer to "Table of Payload by Speed/Acceleration" for more details.
- (2) The Radial Cylinder is equipped with a guide. Please refer to P111 for details of the radial loads applied to the rod.
- (3) The value of the horizontal payload assumes the use of an external guide.
- (4) When performing a push-motion operation, please refer to the "Correlation between push force and current limit value." Push force is only a guide.
- (5) Depending on the ambient operating temperature, duty control is necessary. Please refer to P115 for cautions.
- (6) Special attention needs to be paid to the mounting orientation. Please refer to P33 for details.

Options

Name	Option code	Reference page
Brake	B	See P.101
Tip adapter (flange)	FFA	See P.101
Flange (front)	FL	See P.102
Foot bracket	FT	See P.103
Motor side-mounted to the left (Note 1)	ML	See P.105
Motor side-mounted to the right (Note 1)	MR	See P.105
Tip adapter (female screw)	NFA	See P.106
Knuckle joint (Note 2)	NJ	See P.107
Knuckle joint + oscillation receiving bracket (Note 2)	NJPB	See P.107
Non-motor end specification	NM	See P.108
PNP specification	PN	See P.108
Clevis bracket (Note 2)	QR	See P.108
Clevis bracket + oscillation receiving bracket (Note 2)	QRPB	See P.109
Split motor and controller power supply specification	TMD2	See P.109
Battery-less absolute encoder	WA	See P.109
Wireless communication specification	WL	See P.109
Wireless axis-operation specification	WL2	See P.109

(Note 1) Please make sure to enter a code in the option column of the model spec item.
 (Note 2) Please purchase a clevis bracket (QR or QRPB) and a knuckle joint (NJ or NJPB) together as a set. Mounting is to be done by customer.

Stroke

Stroke (mm)	EC-RR6□R	Stroke (mm)	EC-RR6□R
65	○	215	○
115	○	265	○
165	○	315	○

Cable length

Cable code	Cable length
0	No cable (connector supplied)
1 ~ 3	1 ~ 3m
4 ~ 5	4 ~ 5m
6 ~ 10	6 ~ 10m

(Note) Robot cables.

Main specifications

Item		Description			
Lead	Ball screw lead (mm)	20	12	6	3
	Max. payload (kg) (energy-saving disabled)	6	25	40	60
	Max. payload (kg) (energy-saving enabled)	6	25	40	40
	Max. speed (mm/s)	800	700	450	225
Horizontal	Min. speed (mm/s)	25	15	8	4
	Rated acceleration/deceleration (G)	0.3	0.3	0.3	0.3
	Max. acceleration/deceleration (G)	1	1	1	1
	Max. payload (kg) (energy-saving disabled)	1.5	4	10	12.5
Vertical	Max. payload (kg) (energy-saving enabled)	1	4	10	12.5
	Max. speed (mm/s)	800	700	450	225
	Min. speed (mm/s)	25	15	8	4
	Rated acceleration/deceleration (G)	0.3	0.3	0.3	0.3
Push force	Max. acceleration/deceleration (G)	0.5	0.5	0.5	0.5
	Max. thrust force when pushing (N)*	67	112	224	449
	Max. speed when pushing (mm/s)	20	20	20	20
	Brake specification	Non-excitation actuating solenoid brake			
Brake	Brake holding force (kgf)	1.5	4	10	12.5
	Min. stroke (mm)	65	65	65	65
	Max. stroke (mm)	315	315	315	315
	Stroke pitch (mm)	50	50	50	50

Item	Description
Driving system	Ball screw φ10mm, Rolling C10
Positioning repeatability	±0.05mm
Lost motion	-
Linear guide	Linear motion infinite circulating type
Rod	φ25mm Material: Aluminum Hard alumite treatment
Rod no-rotation precision (Note 3)	0 degree
Ambient operation temperature/humidity	0~40°C, RH 85% or less (Non-condensing)
Degree of protection	IP20
Vibration & shock resistance	4.9m/s ² 100Hz or less
Overseas standards	CE Marking, RoHS (Restriction of Hazardous Substances)
Motor type	Stepper motor
Encoder type	Incremental / battery-less absolute
Number of encoder pulses	800 pulse/rev

(Note 3) The rod tip displacement angle when no load is applied.

* Speed limitation applies to push motion. See the manual or contact IAI.

Table of Payload by Speed and Acceleration/Deceleration

■ Energy-saving disabled Unit of payload is kg. Operations on the blank locations are not possible.

Lead 20

Orientation	Acceleration (G)					
	Horizontal		Vertical			
Speed (mm/s)	0.3	0.5	0.7	1	0.3	0.5
0	6	6	5	5	1.5	1.5
160	6	6	5	5	1.5	1.5
320	6	6	5	3	1.5	1.5
480	6	6	5	3	1.5	1.5
640	6	4	3	2	1.5	1.5
800	4	3			1	1

Lead 12

Orientation	Acceleration (G)					
	Horizontal		Vertical			
Speed (mm/s)	0.3	0.5	0.7	1	0.3	0.5
0	25	18	16	12	4	4
100	25	18	16	12	4	4
200	25	18	16	10	4	4
400	20	14	10	6	4	4
500	15	8	6	4	3.5	3
700	6	2			2	1

Lead 6

Orientation	Acceleration (G)					
	Horizontal		Vertical			
Speed (mm/s)	0.3	0.5	0.7	1	0.3	0.5
0	40	35	30	25	10	10
50	40	35	30	25	10	10
100	40	35	30	25	10	10
200	40	30	25	20	10	10
250	40	27.5	22.5	18	9	8
350	30	14	12	10	5	5
400	18	10	6	5	3	3
450	8	3			2	1

Lead 3

Orientation	Acceleration (G)					
	Horizontal		Vertical			
Speed (mm/s)	0.3	0.5	0.7	1	0.3	0.5
0	60	50	45	40	12.5	12.5
50	60	50	45	40	12.5	12.5
100	60	50	45	40	12.5	12.5
125	60	50	40	30	10	10
175	40	35	25	20	6	5
200	35	23	15	10	5	4
225	16	10			2.5	

■ Energy-saving enabled Unit of payload is kg. Operations on the blank locations are not possible.

Lead 20

Orientation	Acceleration (G)		
	Horizontal	Vertical	Vertical
Speed (mm/s)	0.3	0.7	0.3
0	6	5	1
160	6	5	1
320	6	5	1
480	4	3	1
640	3	1	0.5

Lead 12

Orientation	Acceleration (G)		
	Horizontal	Vertical	Vertical
Speed (mm/s)	0.3	0.7	0.3
0	25	10	4
100	25	10	4
200	25	10	4
300	20	8	3
400	10	5	2
500	5	2	1

Lead 6

Orientation	Acceleration (G)		
	Horizontal	Vertical	Vertical
Speed (mm/s)	0.3	0.7	0.3
0	40	20	10
50	40	20	10
100	40	20	10
150	40	20	8
200	35	18	5
250	10	6	3

Lead 3

Orientation	Acceleration (G)		
	Horizontal	Vertical	Vertical
Speed (mm/s)	0.3	0.7	0.3
0	40	25	12.5
25	40	25	12.5
50	40	25	12.5
75	40	25	12
100	40	25	9
125	40	25	5

Stroke and maximum speed

Lead (mm)	Energy-saving mode	65-215 (per 50mm)	265 (mm)	315 (mm)
20	Disabled		800	
	Enabled		640	
12	Disabled	700	660	480
	Enabled	500		480
6	Disabled	450	325	235
	Enabled	250		235
3	Disabled	225	160	115
	Enabled	125		115

(Unit is mm/s)

Correlation between push force and current limit value

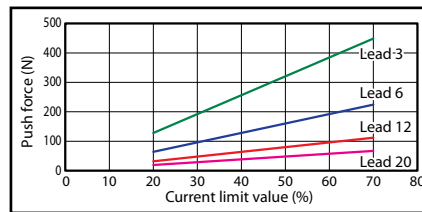

Rod deflection value (reference value)

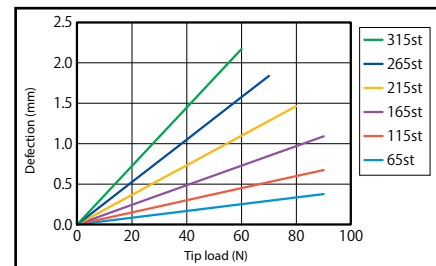

Dimensions

*1 When the rod is returning to its home position, please be careful of interference from surrounding objects, as it will travel until it reaches the M.E.
 *2 The drawing below represents motor side-mounted to the left (ML).
 *3 The direction of width across flats varies depending on the product. This flat cannot be used for reference plane.

CAD drawings can be downloaded from our website.
www.intelligentactuator.com

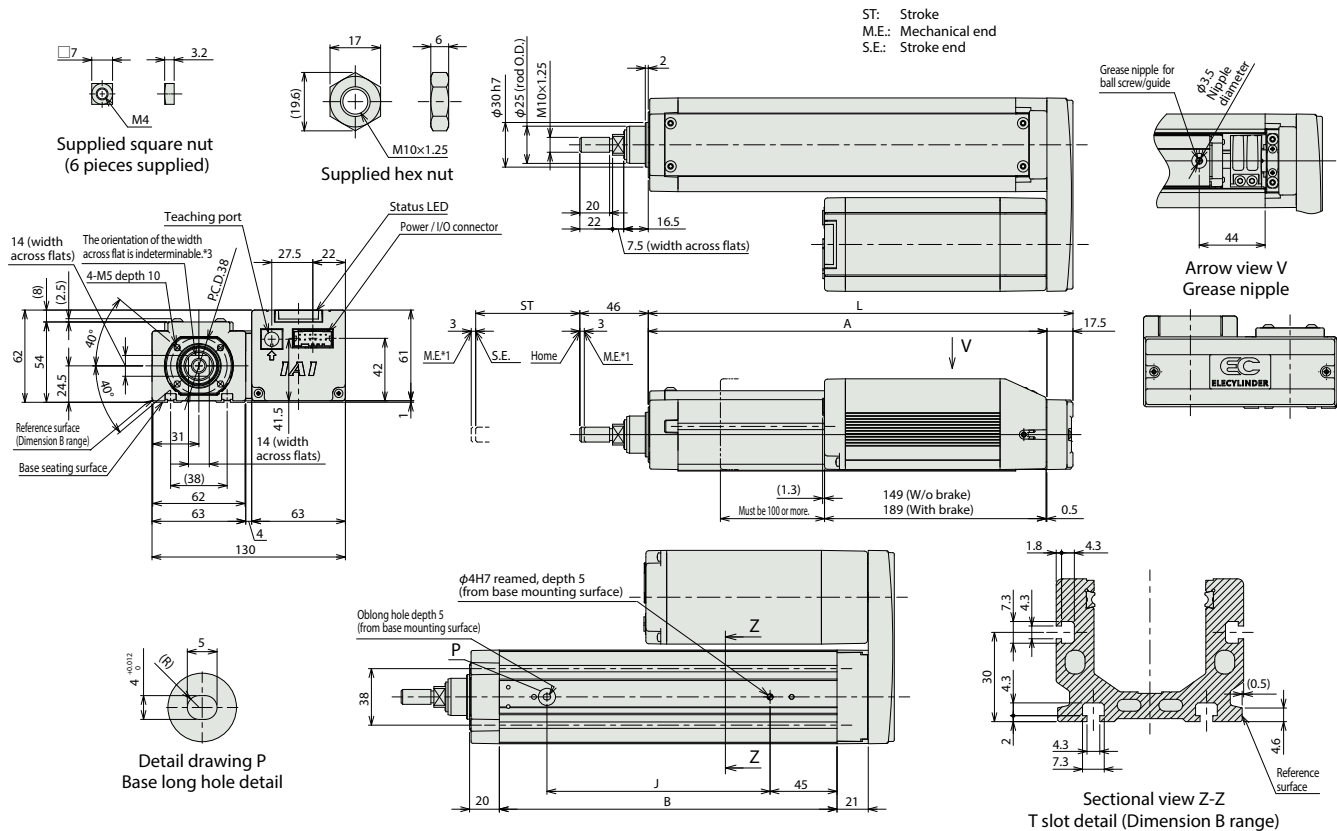

■ Dimensions by stroke

Stroke	65	115	165	215	265	315
L	235.5	285.5	335.5	385.5	435.5	485.5
A	218	268	318	368	418	468
B	177	227	277	327	377	427
J	100	150	200	250	300	350

■ Mass by stroke

Stroke	65	115	165	215	265	315
Weight (kg)	Without brake	2.1	2.4	2.6	2.9	3.4
	With brake	2.3	2.6	2.8	3.1	3.6

Applicable controller

(Note) The EC series is equipped with a built-in controller. Please refer to P116 for details.

EC-RR7□R



Body width
70 mm

24v
Stepper motor

Model Specification Items

EC	—	RR7	<input type="text"/>	R	—	<input type="text"/>	—	<input type="text"/>	—	<input type="text"/>
Series	Type	Lead	Specification	Stroke	Cable Length	Options				
		S 24mm H 16mm M 8mm L 4mm	R Motor side-mounted	65 + 315 65mm 315mm (per 50mm)	0 Terminal type with connector 1 1m + 10 10m	Refer to the price list below				

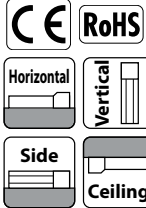

Radial load specification
Radial Cylinder*



(Note) The above photo shows motor side-mounted to the left (ML).

- POINT Selection Notes**
- (1) The actuator specifications display the payload's maximum value, but it will vary depending on the acceleration and speed. Please refer to "Table of Payload by Speed/Acceleration" for more details.
 - (2) The Radial Cylinder is equipped with a guide. Please refer to P111 for details of the radial loads applied to the rod.
 - (3) The value of the horizontal payload assumes the use of an external guide.
 - (4) When performing a push-motion operation, please refer to the "Correlation between Push force and Current Limit Value." Push force is only a guide.
 - (5) Depending on the ambient operating temperature, duty control is necessary. Please refer to P115 for cautions.
 - (6) Special attention needs to be paid to the mounting orientation. Please refer to P33 for details.

Stroke

Stroke (mm)	EC-RR7□R	Stroke (mm)	EC-RR7□R
65	○	215	○
115	○	265	○
165	○	315	○

Cable length

Cable code	Cable length
0	No cable (connector supplied)
1 ~ 3	1 ~ 3m
4 ~ 5	4 ~ 5m
6 ~ 10	6 ~ 10m

(Note) Robot cables.

Options

Name	Option code	Reference page
Brake	B	See P.101
Tip adapter (flange)	FFA	See P.101
Flange (front)	FL	See P.102
Foot bracket	FT	See P.103
Motor side-mounted to the left (Note 1)	ML	See P.105
Motor side-mounted to the right (Note 1)	MR	See P.105
Tip adapter (female screw)	NFA	See P.106
Knuckle joint (Note 2)	NJ	See P.107
Knuckle joint + oscillation receiving bracket (Note 2)	NJPB	See P.107
Non-motor end specification	NM	See P.108
PNP specification	PN	See P.108
Clevis bracket (Note 2)	QR	See P.108
Clevis bracket + oscillation receiving bracket (Note 2)	QRPB	See P.109
Split motor and controller power supply specification	TMD2	See P.109
Battery-less absolute encoder	WA	See P.109
Wireless communication specification	WL	See P.109
Wireless axis-operation specification	WL2	See P.109

(Note 1) Please make sure to enter a code in the option column of the model spec item.
(Note 2) Please purchase a clevis bracket (QR or QRPB) and a knuckle joint (NJ or NJPB) together as a set. Mounting is to be done by customer.

Main specifications

Item		Description				
Lead	Ball screw lead (mm)	24	16	8	4	
Horizontal	Payload	Max. payload (kg) (energy-saving disabled)	20	50	60	80
		Max. payload (kg) (energy-saving enabled)	18	40	50	55
	Speed/acceleration/deceleration	Max. speed (mm/s)	860	700	320	160
		Min. speed (mm/s)	30	20	10	5
		Rated acceleration/deceleration (G)	0.3	0.3	0.3	0.3
Vertical	Payload	Max. payload (kg) (energy-saving disabled)	3	8	18	19
		Max. payload (kg) (energy-saving enabled)	3	5	17.5	19
Vertical	Speed/acceleration/deceleration	Max. speed (mm/s)	640	560	280	140
		Min. speed (mm/s)	30	20	10	5
		Rated acceleration/deceleration (G)	0.3	0.3	0.3	0.3
		Max. acceleration/deceleration (G)	0.5	0.5	0.5	0.5
		Max. thrust force when pushing (N)*	182	273	547	1094
Push force	Max. speed when pushing (mm/s)	20	20	20	20	
		20	20	20	20	
Brake	Brake specification	Non-excitation actuating solenoid brake				
	Brake holding force (kgf)	3	8	18	19	
Stroke	Min. stroke (mm)	65	65	65	65	
	Max. stroke (mm)	315	315	315	315	
	Stroke pitch (mm)	50	50	50	50	

Item	Description
Driving system	Ball screw φ12mm, Rolling C10
Positioning repeatability	±0.05mm
Lost motion	-
Linear guide	Linear motion infinite circulating type
Rod	φ30mm Material: Aluminum Hard alumite treatment
Rod no-rotation precision (Note 3)	0 degree
Ambient operation temperature/humidity	0~40°C, RH 85% or less (Non-condensing)
Degree of protection	IP20
Vibration & shock resistance	4.9m/s ² 100Hz or less
Overseas standards	CE Marking, RoHS (Restriction of Hazardous Substances)
Motor type	Stepper motor
Encoder type	Incremental / battery-less absolute
Number of encoder pulses	800 pulse/rev

(Note 3) The rod tip displacement angle when no load is applied.

* Speed limitation applies to push motion. See the manual or contact IAI.

Table of Payload by Speed and Acceleration/Deceleration

■ Energy-saving disabled Unit of payload is kg. Operations on the blank locations are not possible.

Lead 24

Orientation	Speed (mm/s)	Acceleration (G)				
		0.3	0.5	0.7	1	0.3
0	20	18	15	12	3	3
200	20	18	15	12	3	3
400	20	14	12	8	3	3
420	17	12	10	6	3	3
600	14	6	5	4	2.5	2
640	5	3	2	1.5	2	1
800	5	1	1			
860	2	0.5				

Lead 16

Orientation	Speed (mm/s)	Acceleration (G)				
		0.3	0.5	0.7	1	0.3
0	50	40	35	30	8	8
140	50	40	35	30	8	8
280	50	35	25	20	7	7
420	25	18	14	10	4.5	4
560	10	5	3	1.5	1	1
700	1					

Lead 8

Orientation	Speed (mm/s)	Acceleration (G)				
		0.3	0.5	0.7	1	0.3
0	60	50	45	40	18	18
70	60	50	45	40	18	18
140	60	50	45	40	16	12
210	60	40	31	26	10	9
280	25	10	8	6	3	2.5
320	5					

Lead 4

Orientation	Speed (mm/s)	Acceleration (G)				
		0.3	0.5	0.7	1	0.3
0	80	70	65	60	19	19
35	80	70	65	60	19	19
70	80	70	65	60	19	19
105	80	60	50	40	18	18
140	50	25	15	10	7	5
160	10					

■ Energy-saving enabled Unit of payload is kg. Operations on the blank locations are not possible.

Lead 24

Orientation	Horizontal	Vertical	
	Speed (mm/s)	Acceleration (G)	
	0.3	0.7	0.3
0	18	9.5	3
200	18	9.5	3
420	10	5	1.5
630	1		

Lead 16

Orientation	Horizontal	Vertical	
	Speed (mm/s)	Acceleration (G)	
	0.3	0.7	0.3
0	40	25	5
140	40	25	5
280	18	12	2
420	1.5	1	

Lead 8

Orientation	Horizontal	Vertical	
	Speed (mm/s)	Acceleration (G)	
	0.3	0.7	0.3
0	50	30	17.5
70	50	30	17.5
140	50	30	7
210	14	7	2

Lead 4

Orientation	Horizontal	Vertical	
	Speed (mm/s)	Acceleration (G)	
	0.3	0.7	0.3
0	55	50	19
35	55	50	19
70	55	50	13
105	30	15	2

Stroke and maximum speed

Lead (mm)	Energy-saving mode	65-215 (per 50mm)	265 (mm)	315 (mm)
24	Disabled		860<640>	
	Enabled		630<420>	
16	Disabled		700<560>	
	Enabled		420<280>	
8	Disabled		320<280>	
	Enabled		210	
4	Disabled		160<140>	
	Enabled		105	

(Note) Figures in <> represent vertical operations. (Unit is mm/s)

Correlation between push force and current limit value

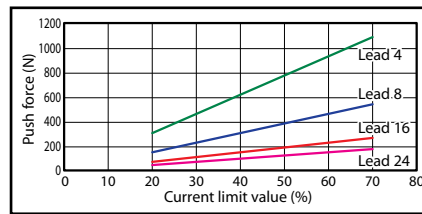

Rod deflection value (reference value)

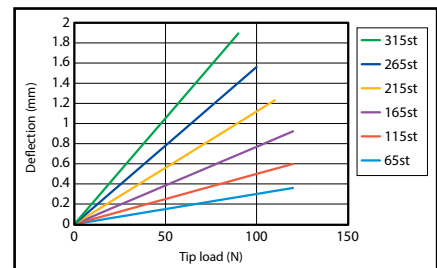

Dimensions

*1 When the rod is returning to its home position, please be careful of interference from surrounding objects, as it will travel until it reaches the M.E.
 *2 The drawing below represents motor side-mounted to the left (ML).
 *3 The direction of width across flats varies depending on the product. This flat cannot be used for reference plane.

CAD drawings can be downloaded from our website.
www.intelligentactuator.com

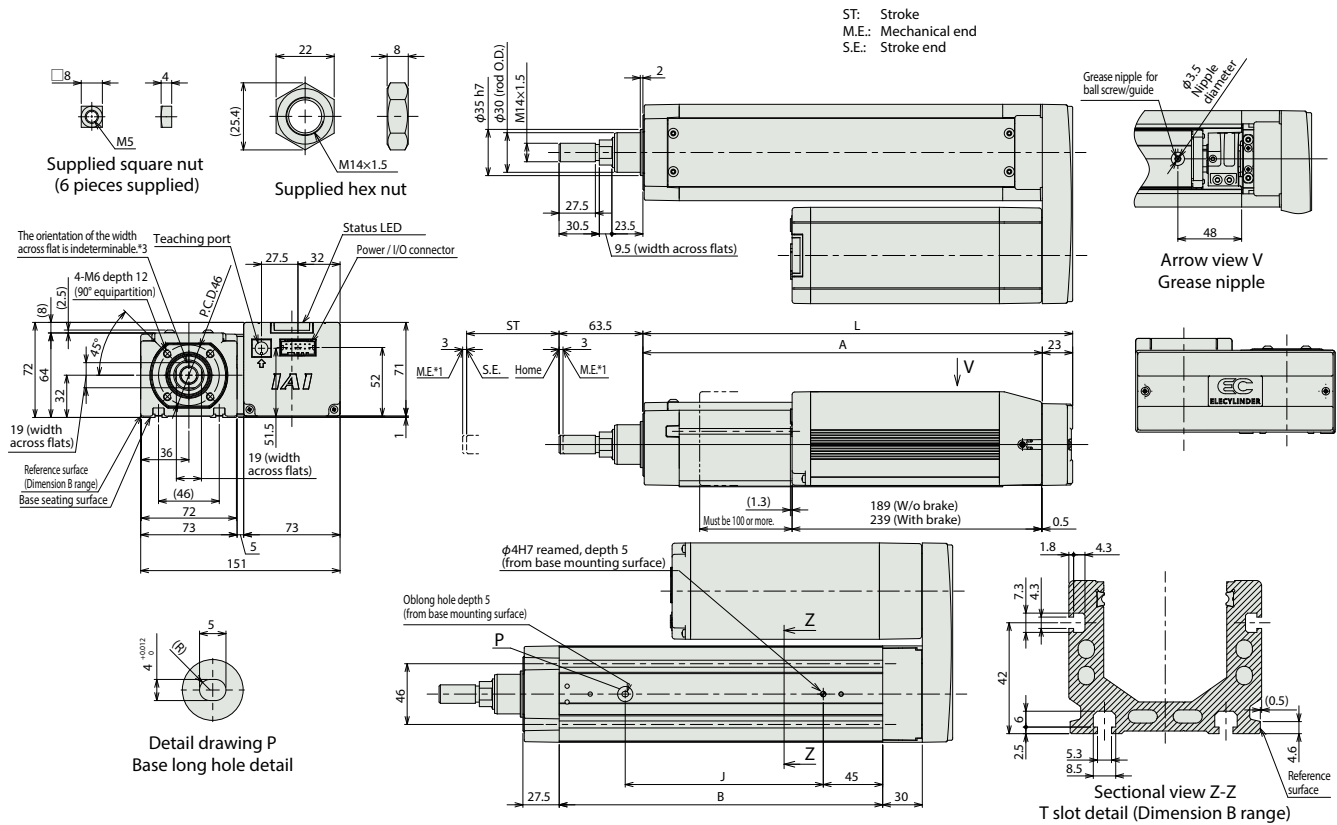

■ Dimensions by stroke

Stroke	65	115	165	215	265	315
L	275.5	325.5	375.5	425.5	475.5	525.5
A	252.5	302.5	352.5	402.5	452.5	502.5
B	195	245	295	345	395	445
J	100	150	200	250	300	350

■ Mass by stroke

Stroke	65	115	165	215	265	315
Weight (kg)	Without brake	4.4	4.8	5.1	5.5	6.2
	With brake	4.9	5.3	5.6	6.0	6.7

Applicable controller

(Note) The EC series is equipped with a built-in controller. Please refer to P116 for details.

EC-RR6 □ AHR

High Rigidity

Side-mounted Motor

Body width 63 mm

24v Stepper motor

Model Specification Items

EC	RR6		AHR			
Series	Type	Lead	Specification	Stroke	Cable Length	Options
		S 20mm H 12mm M 6mm L 3mm	AHR High rigidity with Side-mounted motor	50 100 150 200	50mm 400mm (per 50mm)	0 Terminal type with connector 1 1m 10 10m
						Options Refer to the price list below

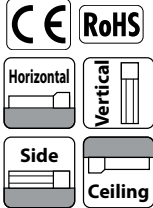

Radial load specification
Radial Cylinder*

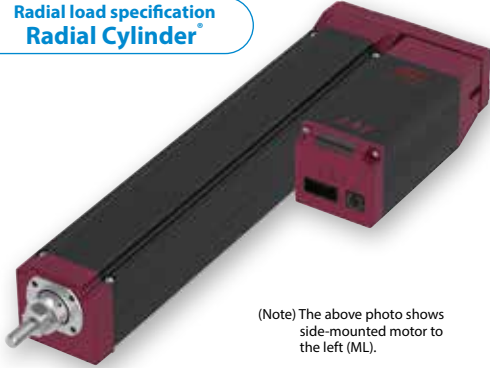

(Note) The above photo shows side-mounted motor to the left (ML).

- POINT Selection Notes**
- (1) The actuator specifications display the payload's maximum value, but it will vary depending on the acceleration and speed. Please refer to "Table of Payload by Speed/Acceleration" for more details.
 - (2) The Radial Cylinder is equipped with a guide. Please refer to P111 for details of the radial loads applied to the rod.
 - (3) The value of the horizontal payload assumes the use of an external guide.
 - (4) When performing a push-motion operation, please refer to the "Correlation between push force and current limit value." Push force is only a guide.
 - (5) Depending on the ambient operating temperature, duty control is necessary. Please refer to P115 for cautions.
 - (6) Special attention needs to be paid to the mounting orientation. Please refer to P33 for details.

Stroke

Stroke (mm)	EC-RR6 □ AHR	Stroke (mm)	EC-RR6 □ AHR
50	○	250	○
100	○	300	○
150	○	350	○
200	○	400	○

Cable length

Cable code	Cable length
0	No cable (connector supplied)
1 ~ 3	1 ~ 3m
4 ~ 5	4 ~ 5m
6 ~ 10	6 ~ 10m

(Note) Robot cables.

Options

Name	Option code	Reference page
Brake	B	See P.101
Tip adapter (flange)	FFA	See P.101
Flange (front)	FL	See P.102
Foot bracket	FT	See P.103
Side-mounted motor to the left (Note 1)	ML	See P.105
Side-mounted motor to the right (Note 1)	MR	See P.105
Tip adapter (female screw)	NFA	See P.106
Knuckle joint (Note 2)	NJ	See P.107
Knuckle joint + oscillation receiving bracket (Note 2)	NJPB	See P.107
Non-motor end specification	NM	See P.108
PNP specification	PN	See P.108
Clevis bracket (Note 2)	QR	See P.108
Clevis bracket + oscillation receiving bracket (Note 2)	QRPB	See P.109
Split motor and controller power supply specification	TMD2	See P.109
Battery-less absolute encoder	WA	See P.109
Wireless communication specification	WL	See P.109
Wireless axis-operation specification	WL2	See P.109

(Note 1) Please make sure to enter a code in the option column of the model spec item.
 (Note 2) Please purchase a clevis bracket (QR or QRPB) and a knuckle joint (NJ or NJPB) together as a set. Mounting is to be done by customer.

Main specifications

Item	Description
Lead	Ball screw lead (mm) 20 12 6 3
Horizontal	Max. payload (kg) (energy-saving disabled) 6 25 40 60
	Max. payload (kg) (energy-saving enabled) 6 25 40 40
	Max. speed (mm/s) 800 700 450 225
	Min. speed (mm/s) 25 15 8 4
Vertical	Max. speed (mm/s) 800 700 450 225
	Min. speed (mm/s) 25 15 8 4
	Max. acceleration/deceleration (G) 0.3 0.3 0.3 0.3
	Max. acceleration/deceleration (G) 0.5 0.5 0.5 0.5
Push force	Max. thrust force when pushing (N)* 67 112 224 449
	Max. speed when pushing (mm/s) 20 20 20 20
Brake	Brake specification Non-excitation actuating solenoid brake
	Brake holding force (kgf) 1.5 4 10 20
Stroke	Min. stroke (mm) 50 50 50 50
	Max. stroke (mm) 400 400 400 400
	Stroke pitch (mm) 50 50 50 50

* Speed limitation applies to push motion. See the manual or contact IAI.

Table of Payload by Speed and Acceleration/Deceleration

■ Energy-saving disabled Unit of payload is kg. Operations on the blank locations are not possible.

Lead 20

Orientation	Horizontal					Vertical				
	Acceleration (G)					Acceleration (G)				
Speed (mm/s)	0.3	0.5	0.7	1	0.3	0.5	0.7	1	0.3	0.5
0	6	6	5	5	1.5	1.5				
160	6	6	5	5	1.5	1.5				
320	6	6	5	3	1.5	1.5				
480	6	6	5	3	1.5	1.5				
640	6	4	3	2	1.5	1.5				
800	4	3			1	1				

Lead 12

Orientation	Horizontal					Vertical				
	Acceleration (G)					Acceleration (G)				
Speed (mm/s)	0.3	0.5	0.7	1	0.3	0.5	0.7	1	0.3	0.5
0	25	18	16	12	4	4				
100	25	18	16	12	4	4				
200	25	18	16	10	4	4				
400	20	14	10	6	4	4				
500	15	8	6	4	3.5	3				
700	6	2			2	1				

Lead 6

Orientation	Horizontal					Vertical				
	Acceleration (G)					Acceleration (G)				
Speed (mm/s)	0.3	0.5	0.7	1	0.3	0.5	0.7	1	0.3	0.5
0	40	35	30	25	10	10				
50	40	35	30	25	10	10				
100	40	35	30	25	10	10				
200	40	30	25	20	10	10				
250	40	27.5	22.5	18	9	8				
350	30	14	12	10	5	4.5				
400	18	10	6	2	3	2.5				
450	8	3			1	0.5				

Lead 3

Orientation	Horizontal					Vertical				
	Acceleration (G)					Acceleration (G)				
Speed (mm/s)	0.3	0.5	0.7	1	0.3	0.5	0.7	1	0.3	0.5
0	60	50	45	40	20	20				
50	60	50	45	40	20	20				
100	60	50	45	40	20	20				
125	60	50	40	30	10	10				
175	40	35	25	20	6	5				
200	35	23	15	5	5	4				
225	16				2					

■ Energy-saving enabled Unit of payload is kg.

Lead 20

Orientation	Horizontal			Vertical
	Acceleration (G)			
Speed (mm/s)	0.3	0.7	0.3	
0	6	5	1	
160	6	5	1	
320	6	5	1	
480	4	3	1	
640	3	1	0.5	

Lead 12

Orientation	Horizontal			Vertical
	Acceleration (G)			
Speed (mm/s)	0.3	0.7	0.3	
0	25	10	4	
100	25	10	4	
200	25	10	4	
300	20	8	3	
400	10	5	2	
500	5	2	1	

Lead 6

Orientation	Horizontal			Vertical
	Acceleration (G)			
Speed (mm/s)	0.3	0.7	0.3	
0	40	20	10	
50	40	20	10	
100	40	20	10	
150	40	20	8	
200	35	18	5	
250	10	6	3	

Lead 3

Orientation	Horizontal			Vertical
	Acceleration (G)			
Speed (mm/s)	0.3	0.7	0.3	
0	40	25	20	
25	40	25	20	
50	40	25	20	
75	40	25	12	
100	40	25	9	
125	40	25	5	

Stroke and maximum speed

Lead (mm)	Energy-saving mode	50-400 (per 50mm)
20	Disabled	800
	Enabled	640
12	Disabled	700
	Enabled	500
6	Disabled	450
	Enabled	250
3	Disabled	225
	Enabled	125

(Unit is mm/s)

Correlation between push force and current limit value

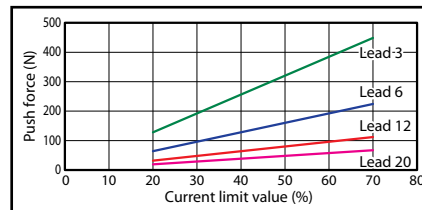

Rod deflection value (reference value)

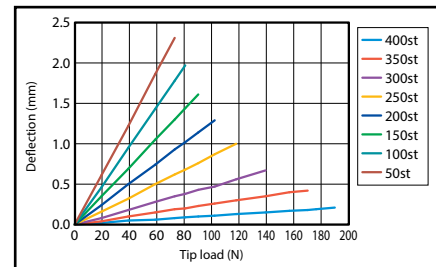

Dimensions

*1 When the rod is returning to its home position, please be careful of interference from surrounding objects, as it will travel until it reaches the M.E.
 *2 The drawing below represents side-mounted motor to the left (ML).
 *3 The direction of width across flats varies depending on the product. This flat cannot be used for reference plane.

CAD drawings can be downloaded from our website.
www.intelligentactuator.com

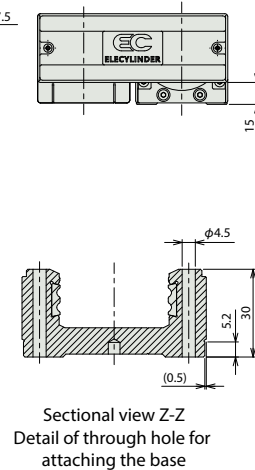
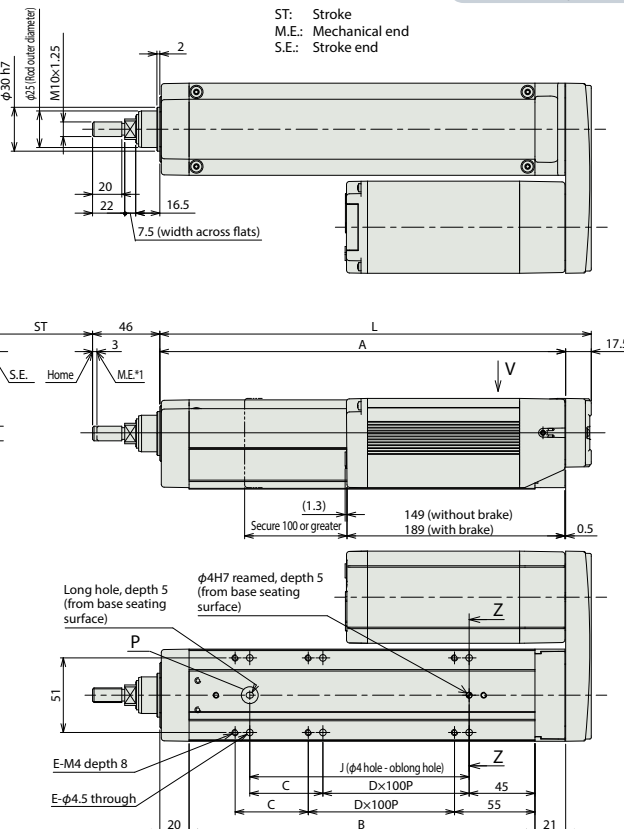
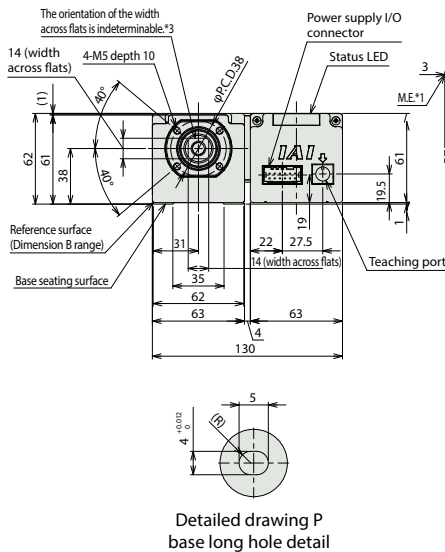
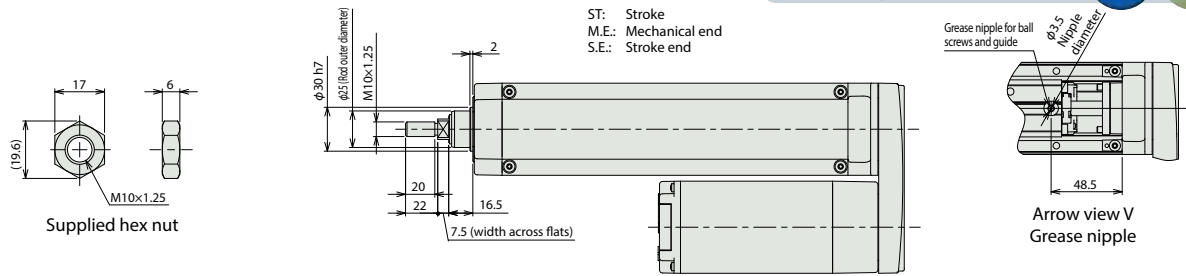

■ Dimensions by stroke

Stroke	50	100	150	200	250	300	350	400
L	345	395	445	495	545	595	645	695
A	227	277	327	377	427	477	527	577
B	186.5	236.5	286.5	336.5	386.5	436.5	486.5	536.5
C	0	50	0	50	0	50	0	50
D	1	1	2	2	3	3	4	4
E	4	6	6	8	8	10	10	12
J	100	150	200	250	300	350	400	450

■ Mass by stroke

Stroke	50	100	150	200	250	300	350	400
Weight (kg)	Without brake	2	2.2	2.5	2.8	3	3.3	3.8
	With brake	2.3	2.5	2.8	3.1	3.3	3.6	4.1

Applicable controller

(Note) The EC series is equipped with a built-in controller. Please refer to P116 for details.

EC-RR7□AHR

High Rigidity

Side-mounted Motor

Body width 75 mm

24v Stepper motor

■ Model Specification Items

EC	RR7		AHR			
Series	Type	Lead	Specification	Stroke	Cable Length	Options
		S 24mm H 16mm M 8mm L 4mm	AHR High rigidity with Side-mounted motor	50 ↑ 500	50mm ↑ 500mm (per 50mm)	0 Terminal type with connector 1 1m ↑ 10 10m
						Refer to the option price list below

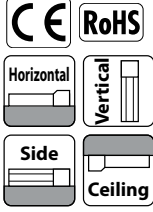

Radial load specification
Radial Cylinder*



(Note) The above photo shows side-mounted motor to the left (ML).

- POINT Selection Notes**
- (1) The actuator specifications display the payload's maximum value, but it will vary depending on the acceleration and speed. Please refer to "Table of Payload by Speed/Acceleration" for more details.
 - (2) The Radial Cylinder is equipped with a guide. Please refer to P111 for details of the radial loads applied to the rod.
 - (3) The value of the horizontal payload assumes the use of an external guide.
 - (4) When performing a push-motion operation, please refer to the "Correlation between push force and current limit value." Push force is only a guide.
 - (5) Depending on the ambient operating temperature, duty control is necessary. Please refer to P115 for cautions.
 - (6) Special attention needs to be paid to the mounting orientation. Please refer to P33 for details.

Stroke			
Stroke (mm)	EC-RR7□AHR	Stroke (mm)	EC-RR7□AHR
50	○	300	○
100	○	350	○
150	○	400	○
200	○	450	○
250	○	500	○

Cable length	
Cable code	Cable length
0	No cable (connector supplied)
1 ~ 3	1 ~ 3m
4 ~ 5	4 ~ 5m
6 ~ 10	6 ~ 10m

(Note) Robot cables.

Options		
Name	Option code	Reference page
Brake	B	See P.101
Tip adapter (flange)	FFA	See P.101
Flange (front)	FL	See P.102
Foot bracket	FT	See P.103
Side-mounted motor to the left (Note 1)	ML	See P.105
Side-mounted motor to the right (Note 1)	MR	See P.105
Tip adapter (female screw)	NFA	See P.106
Knuckle joint (Note 2)	NJ	See P.107
Knuckle joint + oscillation receiving bracket (Note 2)	NJPB	See P.107
Non-motor end specification	NM	See P.108
PNP specification	PN	See P.108
Clevis bracket (Note 2)	QR	See P.108
Clevis bracket + oscillation receiving bracket (Note 2)	QRPB	See P.109
Split motor and controller power supply specification	TMD2	See P.109
Battery-less absolute encoder	WA	See P.109
Wireless communication specification	WL	See P.109
Wireless axis-operation specification	WL2	See P.109

(Note 1) Please make sure to enter a code in the option column of the model spec item.
 (Note 2) Please purchase a clevis bracket (QR or QRPB) and a knuckle joint (NJ or NJPB) together as a set. Mounting is to be done by customer.

Main specifications						
Item		Description				
Lead	Ball screw lead (mm)	24	16	8	4	
Horizontal	Payload	Max. payload (kg) (energy-saving disabled)	20	50	60	80
		Max. payload (kg) (energy-saving enabled)	18	40	50	55
	Speed/acceleration/deceleration	Max. speed (mm/s)	860	700	350	175
		Min. speed (mm/s)	30	20	10	5
		Rated acceleration/deceleration (G)	0.3	0.3	0.3	0.3
Vertical	Payload	Max. payload (kg) (energy-saving disabled)	3	8	18	19
		Max. payload (kg) (energy-saving enabled)	3	5	17.5	19
Vertical	Speed/acceleration/deceleration	Max. speed (mm/s)	640	560	350	175
		Min. speed (mm/s)	30	20	10	5
Push force	Max. thrust force when pushing (N)*	Max. acceleration/deceleration (G)	0.5	0.5	0.5	0.5
		Max. thrust force when pushing (N)*	182	273	547	1094
Brake	Brake specification	Max. speed when pushing (mm/s)	20	20	20	20
		Non-excitation actuating solenoid brake				
Stroke	Brake holding force (kgf)	Min. stroke (mm)	3	8	18	19
		Min. stroke (mm)	65	65	65	65
		Max. stroke (mm)	315	315	315	315
Stroke pitch (mm)		50	50	50	50	

Item		Description
Driving system	Ball screw	φ 12mm, Rolling C10
Positioning repeatability		±0.05mm
Lost motion		-
Linear guide		Linear motion infinite circulating type
Rod		φ 30mm Material: Aluminum Hard alumite treatment
Rod no-rotation precision (Note 3)		0 degree
Ambient operation temperature/humidity		0~40°C, 85%RH or less (Non-condensing)
Degree of protection		IP20
Vibration & shock resistance		4.9m/s ² 100Hz or less
Overseas standards		CE marking, RoHS (Restriction of Hazardous Substances)
Motor type		Stepper motor
Encoder type		Incremental / battery-less absolute
Number of encoder pulses		800 pulse/rev

(Note 3) The rod tip displacement angle when no load is applied.

* Speed limitation applies to push motion. See the manual or contact IAI.

■ Table of Payload by Speed and Acceleration/Deceleration

■ Energy-saving disabled Unit of payload is kg. Operations on the blank locations are not possible.

Lead 24

Orientation	Speed (mm/s)	Acceleration (G)					
		0.3	0.5	0.7	1	0.3	0.5
Horizontal	0	20	18	15	12	3	3
	200	20	18	15	12	3	3
	400	20	14	12	8	3	3
	420	17	12	10	6	3	3
	600	14	6	5	4	2.5	2
	640	5	3	2	1.5	2	1
800	5	1	1				
860	2						

Lead 16

Orientation	Speed (mm/s)	Acceleration (G)					
		0.3	0.5	0.7	1	0.3	0.5
Horizontal	0	50	40	35	30	8	8
	140	50	40	35	30	8	8
	280	50	35	25	20	7	7
	420	25	18	10	10	4	3
	560	7	5	2	1	0.5	0.5
	640	2.5					

Lead 8

Orientation	Speed (mm/s)	Acceleration (G)					
		0.3	0.5	0.7	1	0.3	0.5
Horizontal	0	60	50	45	40	18	18
	70	60	50	45	40	18	18
	140	60	50	45	40	16	12
	210	60	40	31	26	10	9
	280	25	10	8	6	3	2.5
	320	5					

Lead 4

Orientation	Speed (mm/s)	Acceleration (G)					
		0.3	0.5	0.7	1	0.3	0.5
Horizontal	0	80	70	65	60	28	28
	35	80	70	65	60	28	28
	70	80	70	65	60	28	28
	105	80	60	50	40	18	18
	140	40	15	10	5	5	3
	150	20					

■ Energy-saving enabled Unit of payload is kg. Operations on the blank locations are not possible.

Lead 24

Orientation	Acceleration (G)		
	0.3	0.7	0.3
Speed (mm/s)			
0	18	9.5	3
200	18	9.5	3
420	10	5	1.5
630	1		

Lead 16

Orientation	Acceleration (G)		
	0.3	0.7	0.3
Speed (mm/s)			
0	40	25	5
140	40	25	5
280	18	12	2
420	1.5	1	

Lead 8

Orientation	Acceleration (G)		
	0.3	0.7	0.3
Speed (mm/s)			
0	50	30	17.5
70	50	30	17.5
140	50	30	7
210	14	7	1

Lead 4

Orientation	Acceleration (G)		
	0.3	0.7	0.3
Speed (mm/s)			
0	55	50	26
35	55	50	26
70	55	50	13
105	30	15	2

Stroke and maximum speed

Lead (mm)	Energy-saving	50-500 (per 50mm)
24	Disabled	860<640>
	Enabled	630<420>
16	Disabled	640<560>
	Enabled	420<280>
8	Disabled	320<280>
	Enabled	210
4	Disabled	150<140>
	Enabled	105

(Note) Figures in <> represent vertical operations. (Unit is mm/s)

Correlation between push force and current limit value

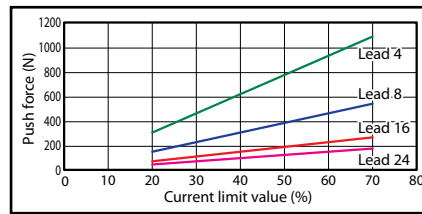

Rod deflection (reference value)

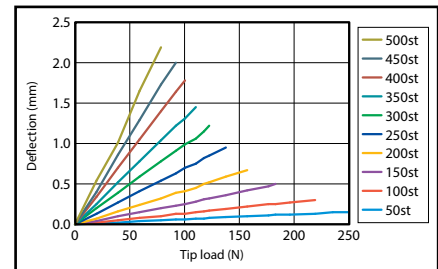

Dimensions

*1 When the rod is returning to its home position, please be careful of interference from surrounding objects, as it will travel until it reaches the M.E.
 *2 The drawing below represents side-mounted motor to the left (ML).
 *3 The direction of width across flats varies depending on the product. This flat cannot be used for reference plane.

CAD drawings can be downloaded from our website.
www.intelligentactuator.com

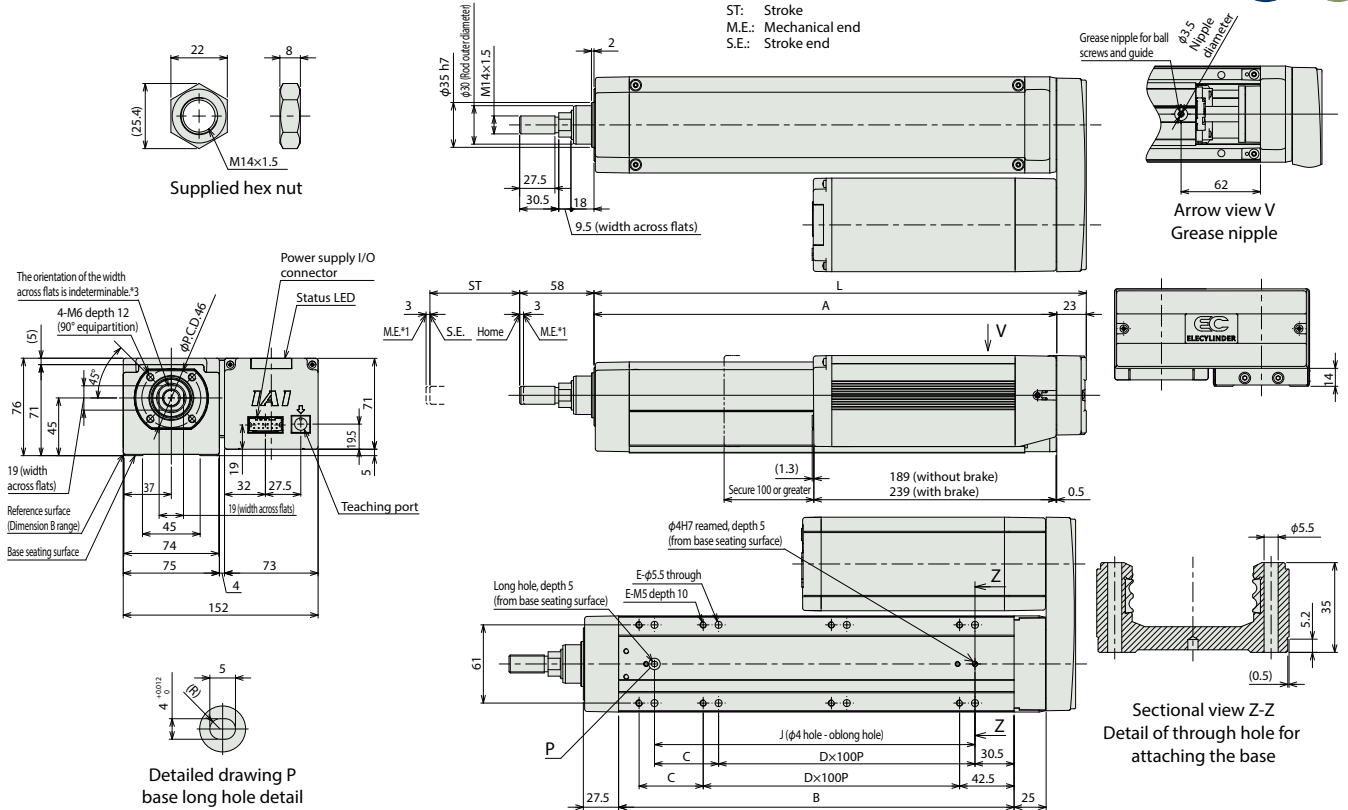

■ Dimensions by stroke

Stroke	50	100	150	200	250	300	350	400	450	500
L	284	334	384	434	484	534	584	634	684	734
A	261	311	361	411	461	511	561	611	661	711
B	208.5	258.5	308.5	358.5	408.5	458.5	508.5	558.5	608.5	658.5
C	50	0	50	0	50	0	50	0	50	0
D	1	2	2	3	3	4	4	5	5	6
E	6	6	8	8	10	10	12	12	14	14
J	150	200	250	300	350	400	450	500	550	600

■ Mass by stroke

Stroke	50	100	150	200	250	300	350	400	450	500
Weight (kg)	Without brake	4.6	5	5.3	5.6	6	6.3	6.6	7	7.3
	With brake	5.1	5.5	5.8	6.1	6.5	6.8	7.1	7.5	7.8

Applicable controller

(Note) The EC series is equipped with a built-in controller. Please refer to P116 for details.

EC-RP4

Mini

Side-mounted
Motor

Body width
30 mm

24v
Stepper motor

Model Specification Items

EC — **RP4** [] — [] — [] — []

Series	Type	Lead	Stroke	Cable Length	Options
		H 6mm M 4mm L 2mm	30 30mm 50 50mm	0 With terminal block type connector 1 1m 1 1m 10 10m	Refer to Options below.



POINT
Selection Notes

- (1) Please use a rotation stop apparatus such as a guide at the tip of the feed screw because it has no rotation stop. (If there is no rotation stop, the feed screw rotates and cannot move back and forth). Do not use floating joints or anything similar when connecting the rotation stop apparatus and the rod. Please refer to P27-32 for mounting method and conditions.
- (2) The actuator specifications display the payload's maximum value, but it will vary depending on the acceleration and speed. Please refer to "Table of Payload by Speed/Acceleration" for more details.
- (3) The value of the horizontal payload assumes the use of an external guide. Please do not apply any external force other than the rod thrust direction.
- (4) When performing a push-motion operation, please refer to the "Correlation between push force and current limit value." Push force is only a guide. Please refer to P115 for cautions.
- (5) Special attention needs to be paid to the mounting orientation. Please refer to P33 for details.

Stroke	
Stroke (mm)	EC-RP4
30	○
50	○

Options			
Name	Option code	Reference page	
Brake	B	See P.101	
PNP specification	PN	See P.108	
Split motor and controller power supply specification	TMD2	See P.109	
Battery-less Absolute Encoder specification	WA	See P.109	
Wireless communication specification	WL	See P.109	
Non-motor end specification	WL2	See P.109	

Cable Length	
Cable code	Cable length
0	No cable (with connector)
1 ~ 3	1 ~ 3m
4 ~ 5	4 ~ 5m
6 ~ 10	6 ~ 10m

(Note) Robot cables.

Main specifications					
Item		Description			
Lead	Ball screw lead (mm)	6	4	2	
Horizontal	Payload	Max. payload (kg)	2.5	4	8
		Max. speed (mm/s)	300	200	100
	Speed/acceleration/deceleration	Min. speed (mm/s)	7.5	5	2.5
		Rated acceleration/deceleration (G)	0.3	0.3	0.3
		Max. acceleration/deceleration (G)	0.5	0.5	0.3
Vertical	Payload	Max. payload (kg)	1	1.5	2.5
		Max. speed (mm/s)	300	200	100
	Speed/acceleration/deceleration	Min. speed (mm/s)	7.5	5	2.5
		Rated acceleration/deceleration (G)	0.3	0.3	0.3
		Max. acceleration/deceleration (G)	0.5	0.5	0.3
Push force	Pushing max. thrust force (N)*	30	45	90	
	Pushing max. speed (mm/s)	20	20	20	
Brake	Brake holding specification		Non-excitation actuating solenoid brake		
	Brake holding force (kgf)		1	1.5	2.5
Stroke	Min. stroke (mm)		30	30	30
	Max. stroke (mm)		50	50	50
	Stroke pitch (mm)		20	20	20

Item		Description
Driving system	Ball screw \varnothing 6mm, Rolling C10	
Positioning repeatability	\pm 0.05mm	
Lost motion	-	
Rod non-rotation accuracy	-	
Operational service life	5,000km or 50 million reciprocating motions	
Ambient operation temperature/humidity	0~40°C, 85%RH or less (Non-condensing)	
Degree of protection	IP20	
Vibration & shock resistance	4.9m/s ² 100Hz or less	
Overseas standards	CE marking, RoHS (Restriction of Hazardous Substances)	
Motor type	Stepper motor	
Encoder type	Incremental / battery-less absolute	
Number of encoder pulses	800 pulse/rev	

* Speed limitation applies to push motion. See the manual or contact IAI.

Table of Payload by Speed/Acceleration											
Unit for payload is kg.											
Lead 6			Lead 4			Lead 2					
Orientation	Horizontal		Horizontal		Vertical		Orientation	Horizontal		Vertical	
	Speed (mm/s)	Acceleration (G)		Speed (mm/s)	Acceleration (G)			Speed (mm/s)	Acceleration (G)		
	0.3	0.5	0.3	0.5		0.3	0.5	0.3	0.5		0.3
0	2.5	2.5	1	1	0	4	4	1.5	1.5	0	8
300	2.5	2.5	1	1	200	4	4	1.5	1.5	100	8

Stroke and maximum speed

Lead (mm)	30 (mm)	50 (mm)
6	300	
4	200	
2	100	

(Unit is mm/s)

Correlation between push force and current limit value

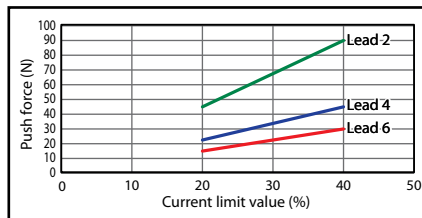

Dimensions

*1 When the rod is returning to its home position, please be careful of interference from surrounding objects, as it will travel until it reaches the M.E.
 *2 The direction of width across flats varies depending on the product. Those flats cannot be used for reference plane.

CAD drawings can be downloaded from our website.
www.intelligentactuator.com

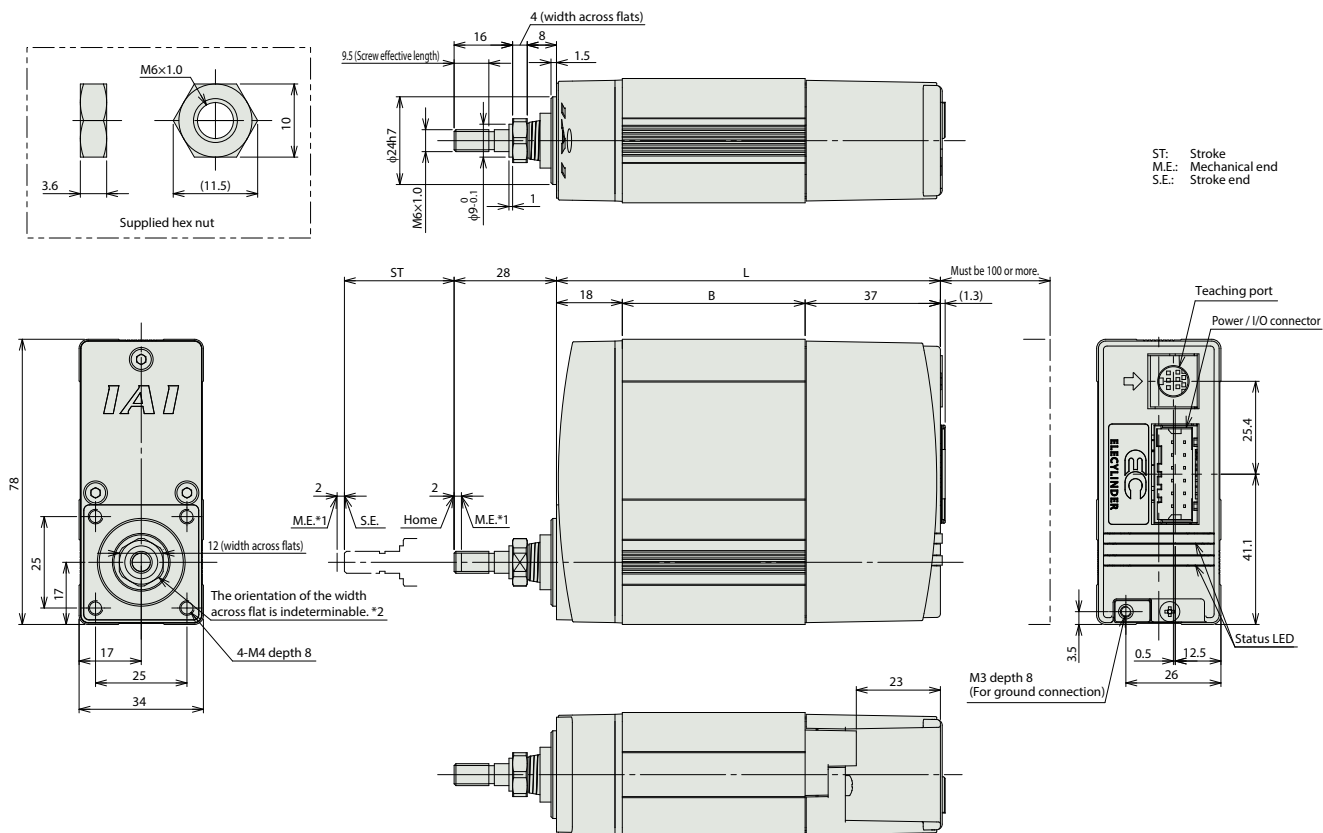

■ Dimensions by stroke

	Encoder type	Incremental		Battery-less absolute	
		Stroke		Stroke	
L	W/o Brake	30	50	30	50
	With Brake	105	125	125	125
B	W/o Brake	135	135	155	155
	With Brake	50	70	70	70
	With Brake	80	80	100	100

■ Mass by stroke

	Encoder type	Incremental		Battery-less absolute	
		Stroke		Stroke	
Weight (kg)	W/o Brake	30	50	30	50
	With Brake	0.5	0.6	0.6	0.6
	With Brake	0.7	0.7	0.7	0.7

Applicable controller

(Note) The EC series is equipped with a built-in controller. Please refer to P116 for details.

EC-GS4

Mini Side-mounted Motor Body width 55 mm 24v Stepper motor

Model Specification Items

EC — GS4

Series	Type	Lead	Stroke	Cable Length	Options
		H 6mm M 4mm L 2mm	30 30mm 50 50mm	0 With terminal block type connector 1 1m 1 1m 10 10m	Refer to Options below.

*Please be sure to select GT2, GT3 or GT4 for the guide mounting direction.



The above photo shows a right side-mount (GT2).



POINT Selection Notes

- The actuator specifications display the payload's maximum value, but it will vary depending on the acceleration and speed. Please refer to "Table of Payload by Speed/Acceleration" for more details.
- The value for horizontal payload assumes the use of an external guide so that radial and moment loads are not applied on the rod. If a guide is not installed, please refer to the "Correlation between Radial Load and Operation Life" (P111).
- When performing a push-motion operation, please refer to the "Correlation between push force and current limit value." Push force is only a guide. Please refer to P115 for cautions.
- Please make sure to select an option code from the option price list below for the guide mounting direction.
- Special attention needs to be paid to the mounting orientation. Please refer to P33 for details.

Stroke	
Stroke (mm)	EC-GS4
30	○
50	○

Options		
Name	Option code	Reference page
Brake	B	See P.101
Guide right mount*	GT2	See P.105
Guide bottom mount*	GT3	See P.105
Guide left mount*	GT4	See P.105
PNP specification	PN	See P.108
Split motor and controller power supply specification	TMD2	See P.109
Battery-less Absolute Encoder specification	WA	See P.109
Wireless communication specification	WL	See P.109
Wireless axis-operation specification	WL2	See P.109

*Please be sure to select GT2, GT3 or GT4 for the guide mounting direction.

Cable Length	
Cable code	Cable length
0	No cable (with connector)
1 ~ 3	1 ~ 3m
4 ~ 5	4 ~ 5m
6 ~ 10	6 ~ 10m

(Note) Robot cables.

Main specifications

Item		Description			
Lead	Ball screw lead (mm)	6	4	2	
	Max. payload (kg)	2.5	4	8	
Horizontal	Speed/acceleration/deceleration	Max. speed (mm/s)	300	200	100
		Min. speed (mm/s)	7.5	5	2.5
		Rated acceleration/deceleration (G)	0.3	0.3	0.3
		Max. acceleration/deceleration (G)	0.5	0.5	0.3
		Max. speed (mm/s)	300	200	100
Vertical	Speed/acceleration/deceleration	Min. speed (mm/s)	7.5	5	2.5
		Rated acceleration/deceleration (G)	0.3	0.3	0.3
		Max. acceleration/deceleration (G)	0.5	0.5	0.3
		Max. speed (mm/s)	300	200	100
		Max. speed (mm/s)	300	200	100
Push force		Pushing max. thrust force (N)*	30	45	90
		Pushing max. speed (mm/s)	20	20	20
Brake	Brake holding specification	Non-excitation actuating solenoid brake			
		Brake holding force (kgf)	1	1.5	2.5
Stroke		Min. stroke (mm)	30	30	30
		Max. stroke (mm)	50	50	50
		Stroke pitch (mm)	20	20	20

Item	Description
Driving system	Ball screw φ6mm, Rolling C10
Positioning repeatability	±0.05mm
Lost motion	-
Rod non-rotation accuracy	-
Operational service life	5,000km or 50 million reciprocating motions
Ambient operation temperature/humidity	0~40°C, 85%RH or less (Non-condensing)
Degree of protection	IP20
Vibration & shock resistance	4.9m/s ² 100Hz or less
Overseas standards	CE marking, RoHS (Restriction of Hazardous Substances)
Motor type	Stepper motor
Encoder type	Incremental / battery-less absolute
Number of encoder pulses	800 pulse/rev

* Speed limitation applies to push motion. See the manual or contact IAI.

Table of Payload by Speed/Acceleration

Unit for payload is kg.

Lead 6

Orientation	Horizontal		Vertical	
	Acceleration (G)			
Speed (mm/s)	0.3	0.5	0.3	0.5
0	2.5	2.5	1	1
300	2.5	2.5	1	1

Lead 4

Orientation	Horizontal				Vertical	
	Acceleration (G)					
Speed (mm/s)	0.3	0.5	0.3	0.5		
0	4	4	1.5	1.5		
200	4	4	1.5	1.5		

Lead 2

Orientation	Horizontal	Vertical
	Acceleration (G)	
Speed (mm/s)	0.3	0.3
0	8	2.5
100	8	2.5

Stroke and maximum speed

Lead (mm)	30 (mm)	50 (mm)
6	300	
4	200	
2	100	

(Unit is mm/s)

Correlation between push force and current limit value

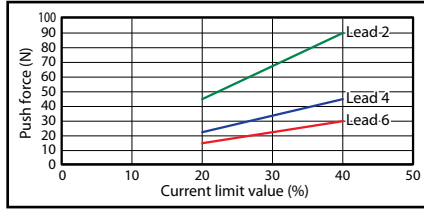

Radial load and operational service life

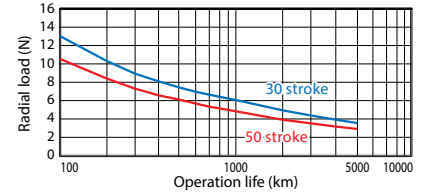
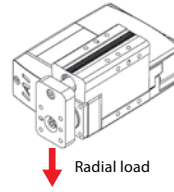

Dimensions

*1 When the rod is returning to its home position, please be careful of interference from surrounding objects, as it will travel until it reaches the M.E.

CAD drawings can be downloaded from our website.
www.intelligentactuator.com

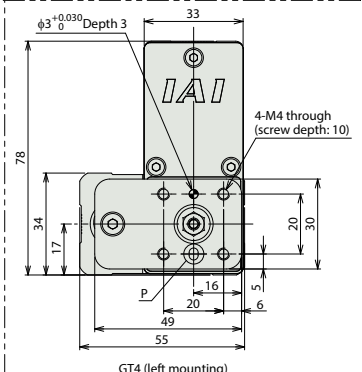
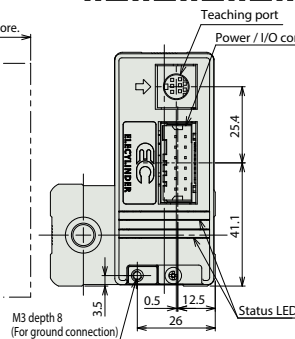
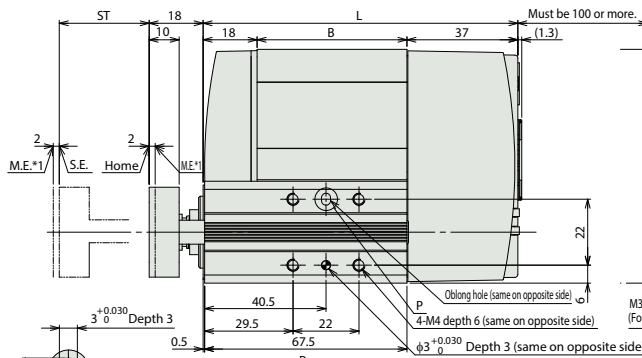
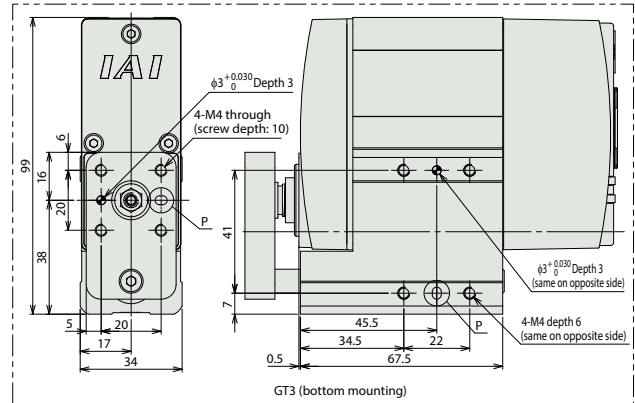
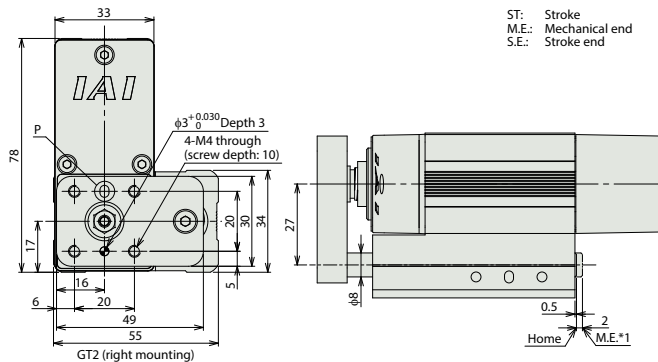

Detailed view of P
Details of oblong hole

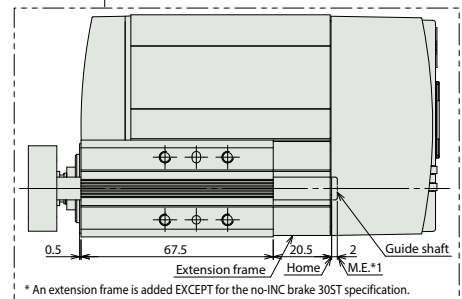
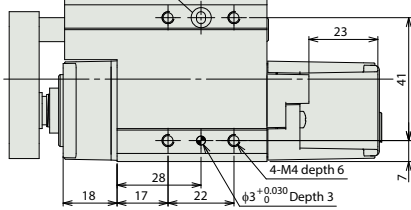

* An extension frame is added EXCEPT for the no-INC brake 30ST specification.

Dimensions by stroke

	Encoder type	Incremental		Battery-less absolute	
		Stroke	30	50	30
L	W/o Brake	105	125	125	125
	With Brake	135	135	155	155
B	W/o Brake	50	70	70	70
	With Brake	80	80	100	100

Mass by stroke

	Encoder type	Incremental		Battery-less absolute	
		Stroke	30	50	30
Weight (kg)	W/o Brake	0.7	0.7	0.7	0.7
	With Brake	0.8	0.8	0.9	0.9

Applicable controller

(Note) The EC series is equipped with a built-in controller. Please refer to P116 for details.

EC-GD4

Mini Side-mounted Motor Body width 80mm 24v Stepper motor

Model Specification Items

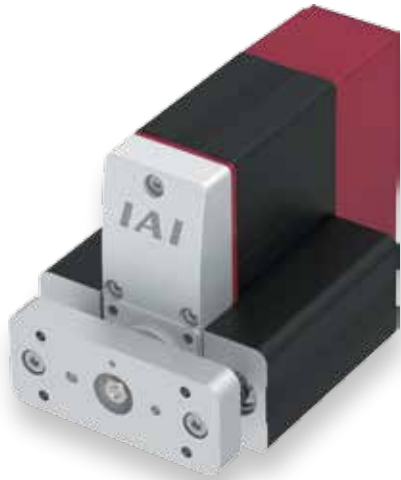
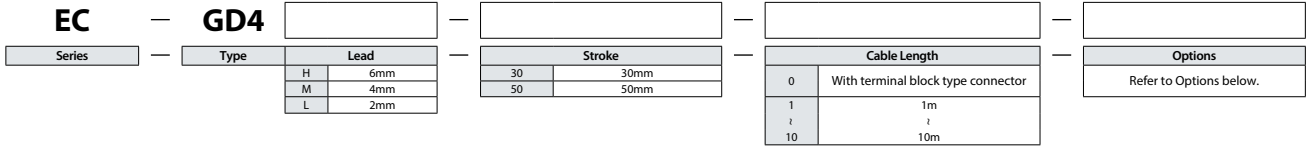

CE RoHS
Horizontal Vertical Side Ceiling

POINT Selection Notes

- (1) The actuator specifications display the payload's maximum value, but it will vary depending on the acceleration and speed. Please refer to "Table of Payload by Speed/Acceleration" for more details.
- (2) The value for horizontal payload assumes the use of an external guide so that radial and moment loads are not applied on the rod. If a guide is not installed, please refer to the "Correlation between Radial Load and Operation Life" (P111).
- (3) When performing a push-motion operation, please refer to the "Correlation between push force and current limit value." Push force is only a guide. Please refer to P115 for cautions.
- (4) Special attention needs to be paid to the mounting orientation. Please refer to P33 for details.

Stroke

Stroke (mm)	EC-GD4
30	○
50	○

Options

Name	Option code	Reference page
Brake	B	See P.101
PNP specification	PN	See P.108
Split motor and controller power supply specification	TMD2	See P.109
Battery-less Absolute Encoder specification	WA	See P.109
Wireless communication specification	WL	See P.109
Wireless axis-operation specification	WL2	See P.109

Cable Length

Cable code	Cable length
0	No cable (with connector)
1 ~ 3	1 ~ 3m
4 ~ 5	4 ~ 5m
6 ~ 10	6 ~ 10m

(Note) Robot cables.

Main specifications

Item		Description			
Lead	Ball screw lead (mm)	6	4	2	
Horizontal	Payload	Max. payload (kg)	2.5	4	8
		Max. speed (mm/s)	300	200	100
		Min. speed (mm/s)	7.5	5	2.5
		Rated acceleration/deceleration (G)	0.3	0.3	0.3
		Max. acceleration/deceleration (G)	0.5	0.5	0.3
Vertical	Payload	Max. payload (kg)	1	1.5	2.5
		Max. speed (mm/s)	300	200	100
		Min. speed (mm/s)	7.5	5	2.5
		Rated acceleration/deceleration (G)	0.3	0.3	0.3
		Max. acceleration/deceleration (G)	0.5	0.5	0.3
Push force	Pushing max. thrust force (N)*	30	45	90	
	Pushing max. speed (mm/s)	20	20	20	
Brake	Brake holding specification	Non-excitation actuating solenoid brake			
	Brake holding force (kgf)	1	1.5	2.5	
Stroke	Min. stroke (mm)	30	30	30	
	Max. stroke (mm)	50	50	50	
	Stroke pitch (mm)	20	20	20	

Item		Description
Driving system	Ball screw ϕ 6mm, Rolling C10	
Positioning repeatability	\pm 0.05mm	
Lost motion	-	
Rod non-rotation accuracy	-	
Operational service life	5,000km or 50 million reciprocating motions	
Ambient operation temperature/humidity	0~40°C, 85%RH or less (Non-condensing)	
Degree of protection	IP20	
Vibration & shock resistance	4.9m/s ² 100Hz or less	
Overseas standards	CE marking, RoHS (Restriction of Hazardous Substances)	
Motor type	Stepper motor	
Encoder type	Incremental / battery-less absolute	
Number of encoder pulses	800 pulse/rev	

* Speed limitation applies to push motion. See the manual or contact IAI.

Table of Payload by Speed/Acceleration

Unit for payload is kg.

Lead 6

Orientation	Horizontal		Vertical	
	Speed (mm/s)	Acceleration (G)	Speed (mm/s)	Acceleration (G)
	0.3	0.5	0.3	0.5
0	2.5	2.5	1	1
300	2.5	2.5	1	1

Lead 4

Orientation	Horizontal				Vertical	
	Speed (mm/s)	Acceleration (G)		Speed (mm/s)	Acceleration (G)	
		0.3	0.5	0.3	0.5	
0	4	4	1.5	1.5		
200	4	4	1.5	1.5		

Lead 2

Orientation	Horizontal		Vertical	
	Speed (mm/s)	Acceleration (G)	Speed (mm/s)	Acceleration (G)
	0.3	0.3		
0	8	2.5		
100	8	2.5		

Stroke and maximum speed

Lead (mm)	30 (mm)	50 (mm)
6	300	
4	200	
2	100	

(Unit is mm/s)

Correlation between push force and current limit value

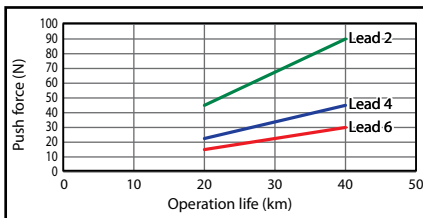

Radial load and operational service life

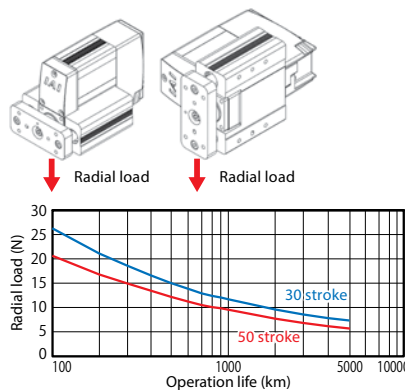

Dimensions

(Note) When the rod is returning to its home position, please be careful of interference from surrounding objects, as it will travel until it reaches the M.E.

CAD drawings can be downloaded from our website.

www.intelligentactuator.com

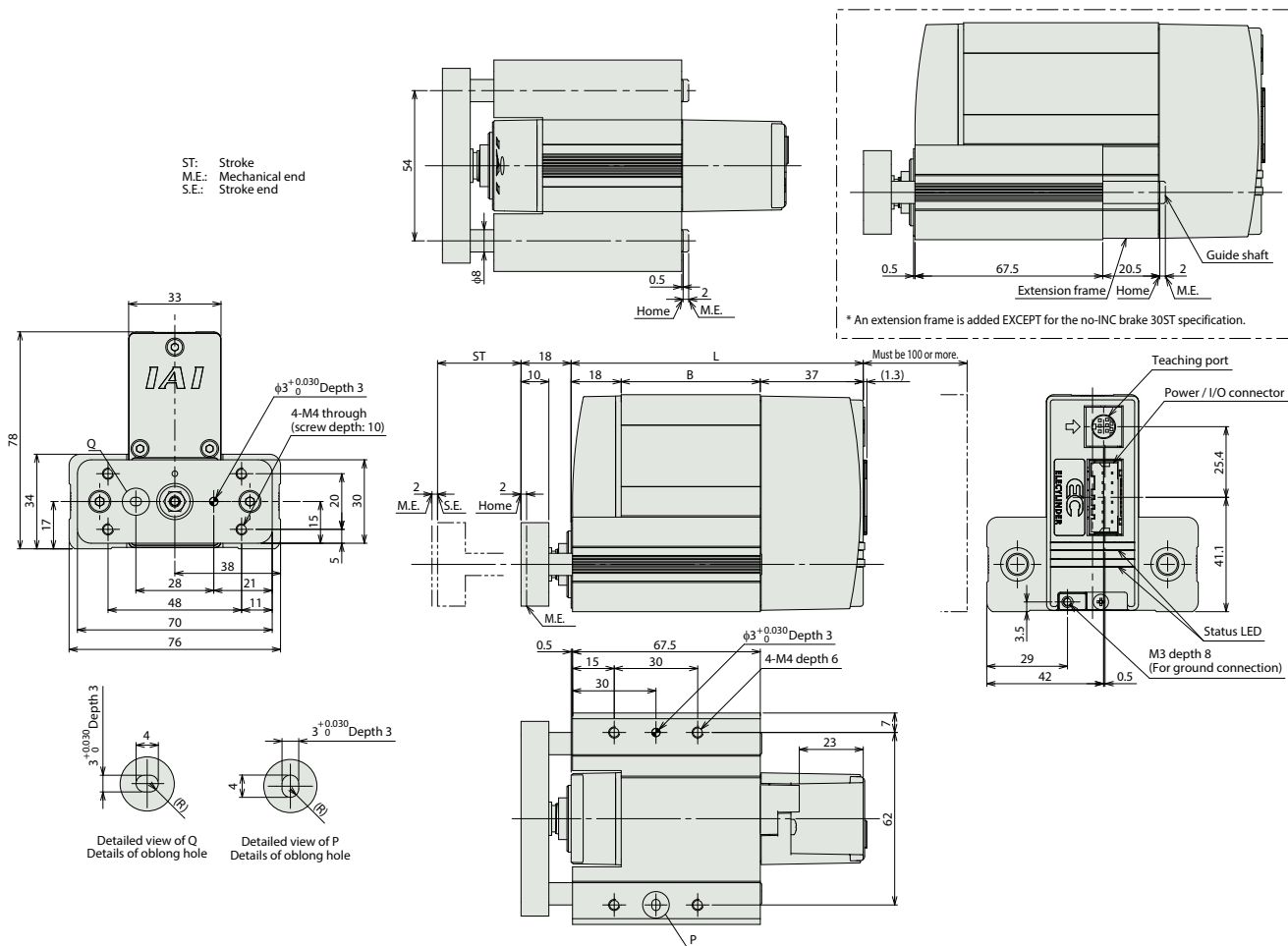

Dimensions by stroke

	Encoder	Incremental		Battery-less absolute	
		30	50	30	50
L	Stroke				
	Without brake	105	125	125	125
	With brake	135	135	155	155
B	Without brake	50	70	70	70
	With brake	80	80	100	100

Mass by stroke

	Encoder	Incremental		Battery-less absolute	
		30	50	30	50
Weight (kg)	Stroke				
	Without brake	0.9	0.9	0.9	0.9
	With brake	1.0	1.0	1.0	1.1

Applicable controller

(Note) The EC series is equipped with a built-in controller. Please refer to P116 for details.

EC-TC4

Mini

Side-mounted Motor

Body width 78 mm

24v Stepper motor

Model Specification Items

EC — **TC4**

Series — Type

Lead	Stroke
H 6mm	30 30mm
M 4mm	50 50mm
L 2mm	

Cable Length

Cable Length	Options
0 With terminal block type connector	Refer to Options below.
1 1m	
2 2m	
10 10m	

*Please be sure to select GT2, GT3 or GT4 for the table mounting direction.

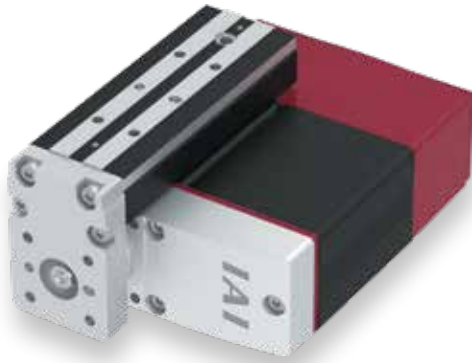

The above photo shows a left side-mount specification (GT4).



- (1) The actuator specifications display the payload's maximum value, but it will vary depending on the acceleration and speed. Please refer to "Table of Payload by Speed/Acceleration" for more details.
- (2) When performing a push-motion operation, please refer to the "Correlation between push force and current limit value." Push force is only a guide. Please refer to P115 for cautions.
- (3) Please make sure to select an option code from the option price list below for the table mounting direction.
- (4) Reference value of the overhang load length is under 100mm in the table top surface of the Ma direction, under 50mm in the table front direction and under 120mm in the Mb and Mc directions.
- (5) Special attention needs to be paid to the mounting orientation. Please refer to P33 for details.

Stroke	
Stroke (mm)	EC-TC4
30	○
50	○

Options			
Name	Option code	Reference page	
Brake	B	See P.101	
Table right mount*	GT2	See P.105	
Table bottom mount*	GT3	See P.105	
Table left mount*	GT4	See P.105	
Non-motor end specification	NM	See P.108	
PNP specification	PN	See P.108	
Split motor and controller power supply specification	TMD2	See P.109	
Battery-less Absolute Encoder specification	WA	See P.109	
Wireless communication specification	WL	See P.109	
Wireless axis-operation specification	WL2	See P.109	

*Please be sure to select GT2, GT3 or GT4 for the table mounting direction.

Cable Length	
Cable code	Cable length
0	No cable (with connector)
1 ~ 3	1 ~ 3m
4 ~ 5	4 ~ 5m
6 ~ 10	6 ~ 10m

(Note) Robot cables.

Main specifications

Item		Description			
Lead	Ball screw lead (mm)	6	4	2	
	Max. payload (kg)	2.5	4	8	
Horizontal	Speed/acceleration/deceleration	Max. speed (mm/s)	300	200	100
	Min. speed (mm/s)	7.5	5	2.5	
	Rated acceleration/deceleration (G)	0.3	0.3	0.3	
	Max. acceleration/deceleration (G)	0.5	0.5	0.3	
	Max. payload (kg)	1	1.5	2.5	
Vertical	Speed/acceleration/deceleration	Max. speed (mm/s)	300	200	100
	Min. speed (mm/s)	7.5	5	2.5	
	Rated acceleration/deceleration (G)	0.3	0.3	0.3	
	Max. acceleration/deceleration (G)	0.5	0.5	0.3	
	Pushing max. thrust force (N)*	30	45	90	
Push force	Pushing max. speed (mm/s)	20	20	20	
	Brake holding specification	Non-excitation actuating solenoid brake			
Brake	Brake holding force (kgf)	1	1.5	2.5	
	Min. stroke (mm)	30	30	30	
Stroke	Max. stroke (mm)	50	50	50	
	Stroke pitch (mm)	20	20	20	

* Speed limitation applies to push motion. See the manual or contact IAI.

Item	Description
Driving system	Ball screw ϕ 6mm, Rolling C10
Positioning repeatability	\pm 0.05mm
Lost motion	-
Static allowable moment	Ma: 5N·m
	Mb: 5N·m
	Mc: 9N·m
Dynamic allowable moment (Note 1)	Ma: 3N·m
	Mb: 3N·m
Operational service life	5,000km or 50 million reciprocating motions
Ambient operation temperature/humidity	0~40°C, 85%RH or less (Non-condensing)
Degree of protection	-
Vibration & shock resistance	4.9m/s ² 100Hz or less
Overseas standards	CE marking, RoHS (Restriction of Hazardous Substances)
Motor type	Stepper motor
Encoder type	Incremental / battery-less absolute
Number of encoder pulses	800 pulse/rev

(Note 1) Based on the standard rated operation life of 5,000 km. Operation life varies according to operating and mounting conditions. Confirm the operation life on P36.

Direction of moment for the Table type



Table of Payload by Speed/Acceleration

Unit for payload is kg.

Lead 6

Orientation	Horizontal		Vertical	
	Acceleration (G)			
Speed (mm/s)	0.3	0.5	0.3	0.5
0	2.5	2.5	1	1
300	2.5	2.5	1	1

Lead 4

Orientation	Horizontal		Vertical	
	Acceleration (G)			
Speed (mm/s)	0.3	0.5	0.3	0.5
0	4	4	1.5	1.5
200	4	4	1.5	1.5

Stroke and maximum speed

Lead (mm)	30 (mm)	50 (mm)
6	300	
4	200	
2	100	

(Unit is mm/s)

Correlation between push force and current limit value

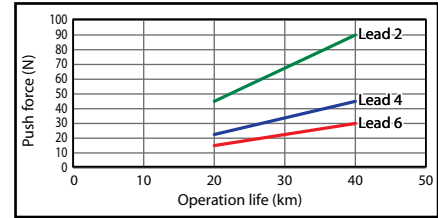

Dimensions

(Note) When the table is returning to its home position, please be careful of interference from surrounding objects, as it will travel until it reaches the M.E.

CAD drawings can be downloaded from our website.
www.intelligentactuator.com

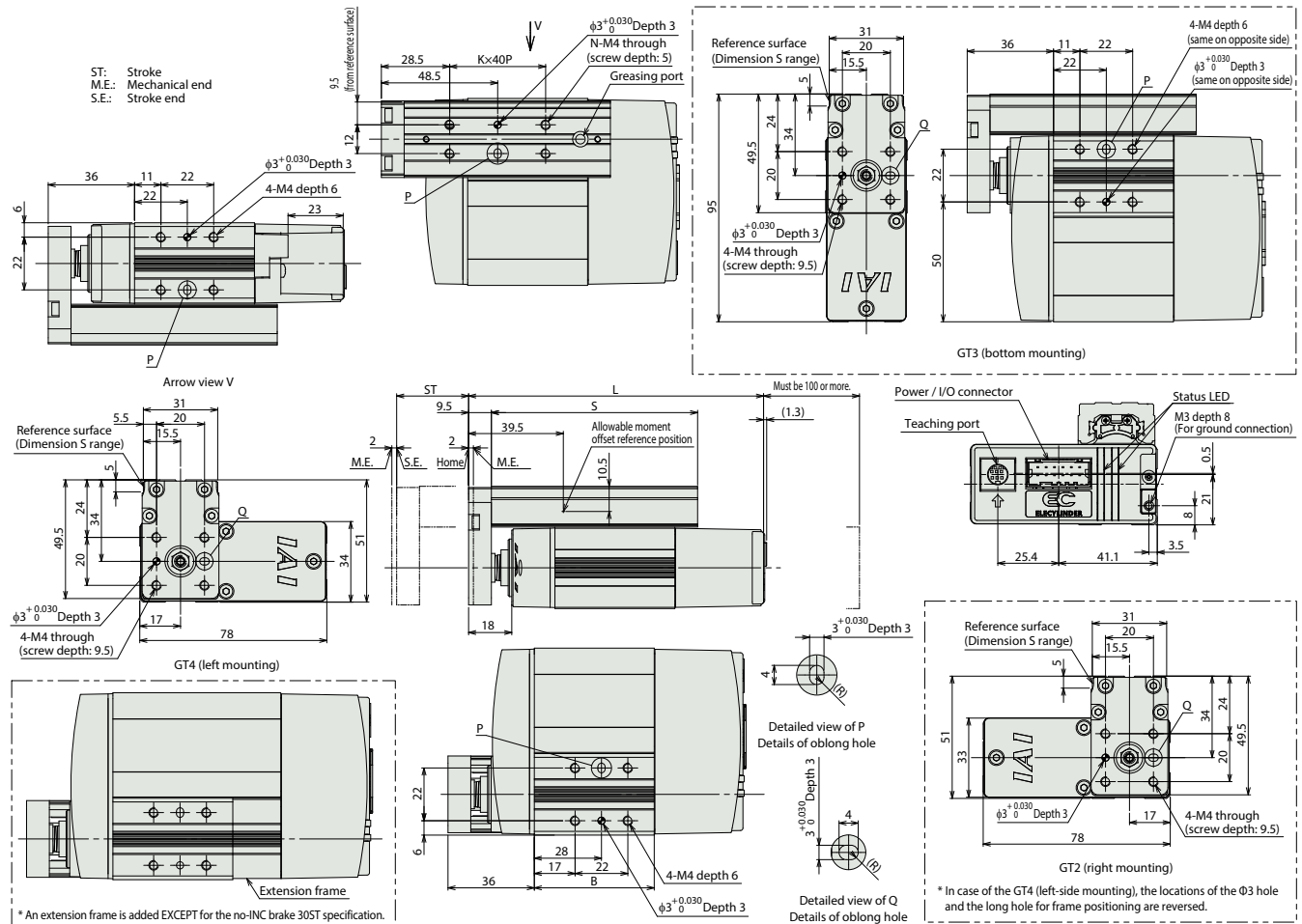

Dimensions by stroke

Encoder type	Incremental			Battery-less absolute	
	Stroke	30	50	30	50
L	Without brake	123	143	143	143
	With brake	153	153	173	173
B	Without brake	50	70	70	70
	With brake	80	80	100	100
S		86	106	86	106
K		1	2	1	2
N		4	6	4	6

Mass by stroke

Encoder type	Incremental			Battery-less absolute	
	Stroke	30	50	30	50
Weight (kg)	Without brake	0.6	0.7	0.7	0.7
	With brake	0.8	0.8	0.8	0.8

Applicable controller

(Note) The EC series is equipped with a built-in controller. Please refer to P116 for details.

EC-TW4

Mini



Body width
80 mm

24v
Stepper motor

Model Specification Items

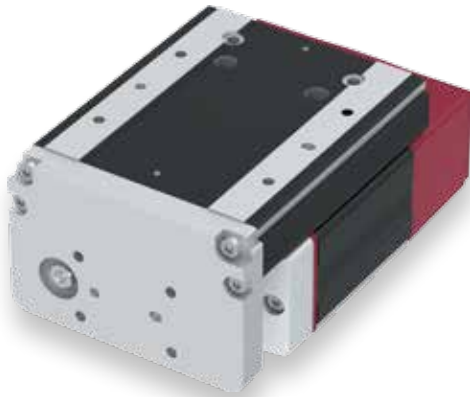
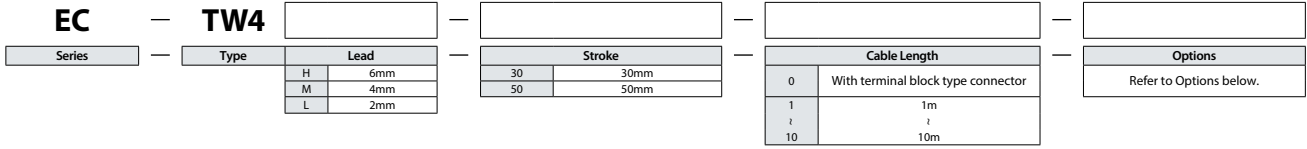

- (1) The actuator specifications display the payload's maximum value, but it will vary depending on the acceleration and speed. Please refer to "Table of Payload by Speed/Acceleration" for more details.
- (2) When performing a push-motion operation, please refer to the "Correlation between push force and current limit value." Push force is only a guide. Please refer to P115 for cautions.
- (3) Reference value of the overhang load length is under 100mm in the Ma direction of the table top direction, under 50mm in the table front direction and under 120mm in the Mb and Mc directions.
- (4) Special attention needs to be paid to the mounting orientation. Please refer to P33 for details.

Stroke	
Stroke (mm)	EC-TW4
30	○
50	○

Options		
Name	Option code	Reference page
Brake	B	See P.101
Non-motor end specification	NM	See P.108
PNP specification	PN	See P.108
Split motor and controller power supply specification	TMD2	See P.109
Battery-less Absolute Encoder specification	WA	See P.109
Wireless communication specification	WL	See P.109
Wireless axis-operation specification	WL2	See P.109

Cable Length	
Cable code	Cable length
0	No cable (with connector)
1 ~ 3	1 ~ 3m
4 ~ 5	4 ~ 5m
6 ~ 10	6 ~ 10m

(Note) Robot cables.

Main specifications					
Item		Description			
Lead	Ball screw lead (mm)	6	4	2	
Horizontal	Payload	Max. payload (kg)	2.5	4	8
		Max. speed (mm/s)	300	200	100
	Speed/acceleration/deceleration	Min. speed (mm/s)	7.5	5	2.5
		Rated acceleration/deceleration (G)	0.3	0.3	0.3
		Max. acceleration/deceleration (G)	0.5	0.5	0.3
Vertical	Payload	Max. payload (kg)	1	1.5	2.5
		Max. speed (mm/s)	300	200	100
	Speed/acceleration/deceleration	Min. speed (mm/s)	7.5	5	2.5
		Rated acceleration/deceleration (G)	0.3	0.3	0.3
		Max. acceleration/deceleration (G)	0.5	0.5	0.3
Push force	Pushing max. thrust force (N)*	30	45	90	
	Pushing max. speed (mm/s)	20	20	20	
Brake	Brake holding specification	Non-excitation actuating solenoid brake			
	Brake holding force (kgf)	1	1.5	2.5	
Stroke	Min. stroke (mm)	30	30	30	
	Max. stroke (mm)	50	50	50	
	Stroke pitch (mm)	20	20	20	

* Speed limitation applies to push motion. See the manual or contact IAI.

Item	Description
Driving system	Ball screw ϕ 6mm, Rolling C10
Positioning repeatability	\pm 0.05mm
Lost motion	-
Static allowable moment	Ma: 8N·m
	Mb: 8N·m
	Mc: 26N·m
Dynamic allowable moment (Note 1)	Ma: 5N·m
	Mb: 5N·m
	Mc: 17N·m
Operational service life	5,000km or 50 million reciprocating motions
Ambient operation temperature/humidity	0~40°C, 85%RH or less (Non-condensing)
Degree of protection	-
Vibration & shock resistance	4.9m/s ² 100Hz or less
Overseas standards	CE marking, RoHS (Restriction of Hazardous Substances)
Motor type	Stepper motor
Encoder type	Incremental / battery-less absolute
Number of encoder pulses	800 pulse/rev

(Note 1) Based on the standard rated operation life of 5,000 km. Operation life varies according to operating and mounting conditions. Confirm the operation life on P36.

Direction of moment for the Table type

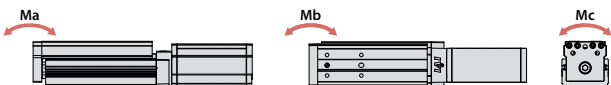

Table of Payload by Speed/Acceleration

Unit for payload is kg.

Lead 6

Orientation	Horizontal		Vertical	
	Acceleration (G)			
Speed (mm/s)	0.3	0.5	0.3	0.5
0	2.5	2.5	1	1
300	2.5	2.5	1	1

Lead 4

Orientation	Horizontal				Vertical	
	Acceleration (G)					
Speed (mm/s)	0.3	0.5	0.3	0.5		
0	4	4	1.5	1.5		
200	4	4	1.5	1.5		

Stroke and maximum speed

Lead (mm)	30 (mm)	50 (mm)
6	300	
4	200	
2	100	

(Unit is mm/s)

Correlation between push force and current limit value

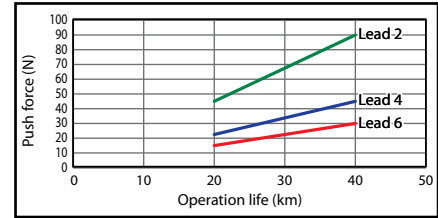

Dimensions

(Note) When the table is returning to its home position, please be careful of interference from surrounding objects, as it will travel until it reaches the M.E.

CAD drawings can be downloaded from our website.
www.intelligentactuator.com



ST: Stroke
M.E.: Mechanical end
S.E.: Stroke end

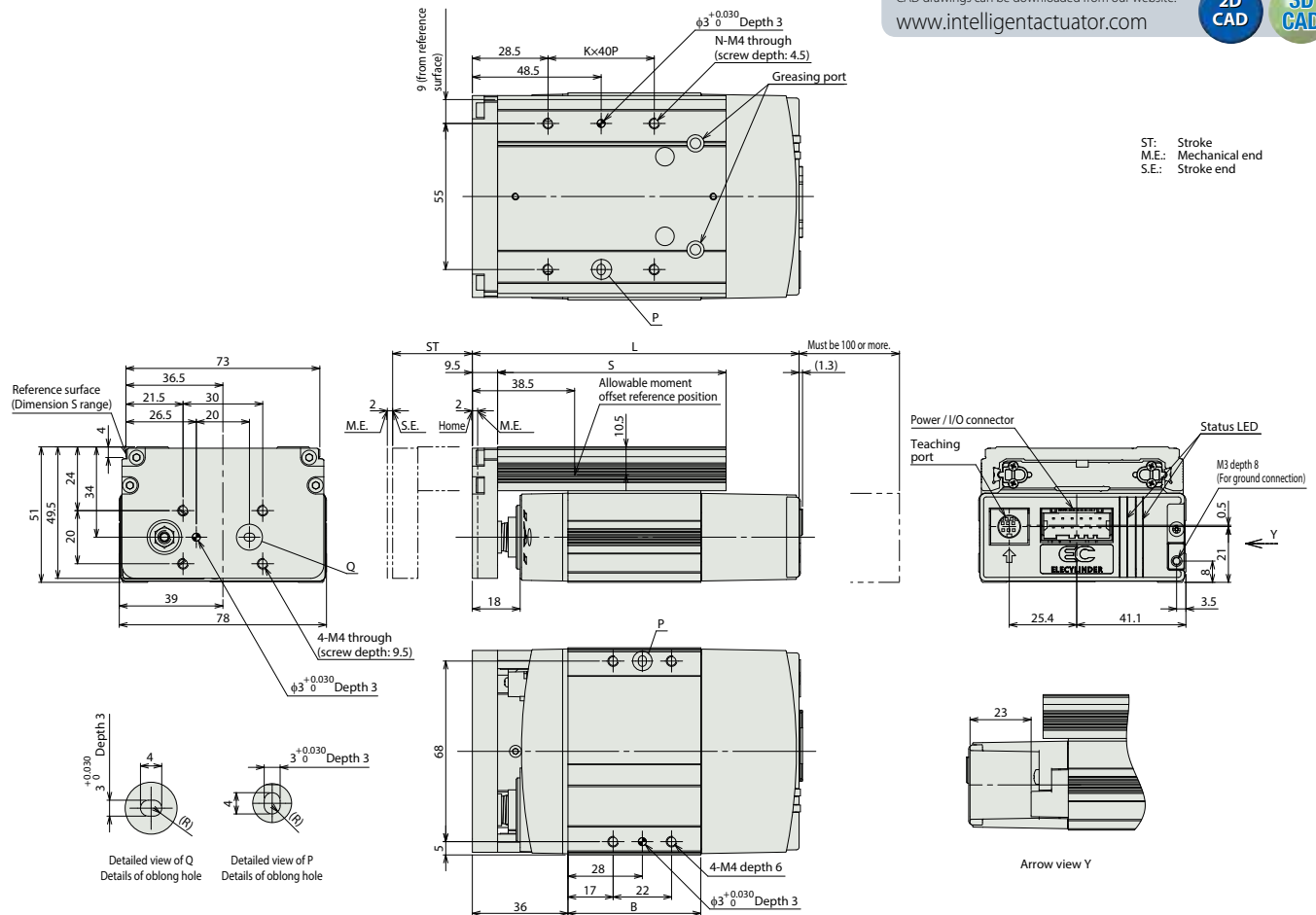

Dimensions by stroke

Encoder type	Stroke	Incremental		Battery-less absolute	
		30	50	30	50
L	Without brake	123	143	143	143
	With brake	153	153	173	173
B	Without brake	50	70	70	70
	With brake	80	80	100	100
S		86	106	86	106
K		1	2	1	2
N		4	6	4	6

Mass by stroke

Encoder type	Stroke	Incremental		Battery-less absolute	
		30	50	30	50
Weight (kg)	Without brake	0.8	0.9	0.8	0.9
	With brake	0.9	1.0	1.0	1.0

Applicable controller

(Note) The EC series is equipped with a built-in controller. Please refer to P116 for details.

EC-R6□W

Dust/Splash-proof

Coupled Motor

Body width 60 mm

24v Stepper motor

Model Specification Items

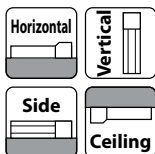
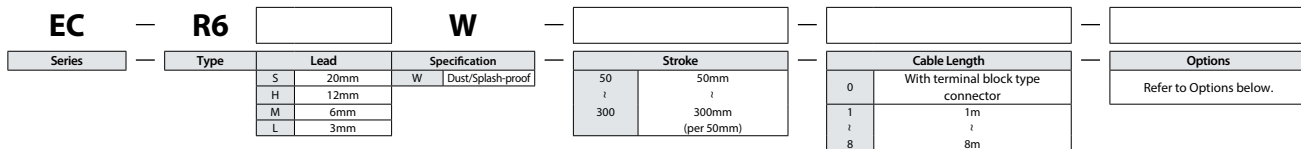

- POINT Selection Notes**
- (1) The actuator specifications display the payload's maximum value, but when energy-saving is activated, the specifications will change. Please refer to "Table of Payload by Speed/Acceleration" for more details.
 - (2) The value of the horizontal payload assumes that there is an external guide. Please be aware that the anti-rotation stopper can be damaged when an external force is applied to the rod from any direction other than the moving direction.
 - (3) When performing a push-motion operation, please refer to the "Correlation between push force and current limit value." Push force is only a guide. Please refer to P115 for details.
 - (4) Depending on the ambient operating temperature, duty control is necessary. Please refer to P115 for details.
 - (5) Interface box is not processed for dust- and splash-proof. Please install it where there is no water splash.
 - (6) Special attention needs to be paid to the mounting orientation. Please refer to P33 for details.

Stroke (mm)	EC-R6□W	Stroke (mm)	EC-R6□W
50	○	200	○
100	○	250	○
150	○	300	○

Cable code	Cable length
0	No cable (with connector)
1 ~ 3	1 ~ 3m
4 ~ 5	4 ~ 5m
6 ~ 10	6 ~ 10m

(Note) Select the actuator cable and the power supply I/O cable so that their total length is under 10m.
(Note) Robot cables.

Name	Option code	Reference page
Actuator cable length 5m	AC5	See P.101
Brake	B	See P.101
Flange (front)	FL	See P.102
Foot bracket	FT	See P.103
Tip adapter (female screw)	NFA	See P.106
Non-motor end specification	NM	See P.108
PNP specification	PN	See P.108
Split motor and controller power supply specification	TMD2	See P.109
Battery-less absolute encoder	WA	See P.109
Wireless communication specification	WL	See P.109
Wireless axis-operation specification	WL2	See P.109

Main specifications

Item		Description				
Lead	Ball screw lead (mm)	20	12	6	3	
Horizontal	Payload	Max. payload (kg) (energy-saving disabled)	6	25	40	60
		Max. payload (kg) (energy-saving enabled)	6	25	40	40
	Speed/acceleration/deceleration	Max. speed (mm/s)	800	700	450	225
		Min. speed (mm/s)	25	15	8	4
		Rated acceleration/deceleration (G)	0.3	0.3	0.3	0.3
Vertical	Payload	Max. payload (kg) (energy-saving disabled)	1.5	4	10	12.5
		Max. payload (kg) (energy-saving enabled)	1	4	10	12.5
	Speed/acceleration/deceleration	Max. speed (mm/s)	800	700	450	225
		Min. speed (mm/s)	25	15	8	4
		Rated acceleration/deceleration (G)	0.3	0.3	0.3	0.3
Push force	Pushing max. thrust force (N)*	67	112	224	449	
	Pushing max. speed (mm/s)	20	20	20	20	
Brake	Brake holding specification	Non-excitation actuating solenoid brake				
	Brake holding force (kgf)	1.5	4	10	12.5	
Stroke	Min. stroke (mm)	50	50	50	50	
	Max. stroke (mm)	300	300	300	300	
	Stroke pitch (mm)	50	50	50	50	

Item	Description	
Driving system	Ball screw φ10mm, Rolling C10	
Positioning repeatability	±0.05mm	
Lost motion	-	
Main material	Rod	Material: Aluminum, White alumite treatment
	Frame	Material: Aluminum, Black alumite treatment
	Dust seal	Rubber (NBR)
	Actuator cable	Polyvinyl chloride (PVC)
Rod non-rotation accuracy (Note 1)	±1.5 degree	
Allowable load and torque on the rod tip.	0.5N·m	
Ambient operation temperature/humidity	0~40°C, 85%RH or less (Non-condensing)	
Degree of protection	IP67	
Vibration & shock resistance	4.9m/s ² 100Hz or less	
Overseas standards	CE marking, RoHS (Restriction of Hazardous Substances)	
Motor type	Stepper motor	
Encoder type	Incremental / battery-less absolute	
Number of encoder pulses	800 pulse/rev	

(Note 1) The rod tip displacement angle (initial reference value) when allowable static torque is applied on rod tip when most of the rod is in the body.

* Speed limitation applies to push motion. See the manual or contact IAI.

Table of Payload by Speed/Acceleration

Setting for energy-saving disabled Unit for payload is kg. Operations on the blank locations are not possible.

Orientation	Acceleration (G)					
	0.3	0.5	0.7	1	0.3	0.5
Speed (mm/s)						
0	6	6	5	5	1.5	1.5
160	6	6	5	5	1.5	1.5
320	6	6	5	3	1.5	1.5
480	6	6	5	3	1.5	1.5
640	6	4	3	2	1.5	1.5
800	4	3			1	1

Orientation	Acceleration (G)					
	0.3	0.5	0.7	1	0.3	0.5
Speed (mm/s)						
0	25	18	16	12	4	4
100	25	18	16	12	4	4
200	25	18	16	10	4	4
400	20	14	10	6	4	4
500	15	8	6	4	3.5	3
700	6	2			2	1

Orientation	Acceleration (G)					
	0.3	0.5	0.7	1	0.3	0.5
Speed (mm/s)						
0	40	35	30	25	10	10
50	40	35	30	25	10	10
100	40	35	30	25	10	10
200	40	30	25	20	10	10
250	40	27.5	22.5	18	9	8
350	30	14	12	10	5	5
400	18	10	6	5	3	3
450	8	3			2	1

Orientation	Acceleration (G)					
	0.3	0.5	0.7	1	0.3	0.5
Speed (mm/s)						
0	60	50	45	40	12.5	12.5
50	60	50	45	40	12.5	12.5
100	60	50	45	40	12.5	12.5
125	60	50	40	30	10	10
175	40	35	25	20	6	5
200	35	30	20	14	5	4.5
225	16	16	10	6	5	4

■ Setting for energy-saving enabled Unit for payload is kg.

Lead 20

Orientation	Horizontal			Vertical
	Acceleration (G)			
Speed (mm/s)	0.3	0.7	0.3	
0	6	5	1	
160	6	5	1	
320	6	5	1	
480	4	3	1	
640	3	1	0.5	

Lead 12

Orientation	Horizontal			Vertical
	Acceleration (G)			
Speed (mm/s)	0.3	0.7	0.3	
0	25	10	4	
100	25	10	4	
200	25	10	4	
300	20	8	3	
400	10	5	2	
500	5	2	1	

Lead 6

Orientation	Horizontal			Vertical
	Acceleration (G)			
Speed (mm/s)	0.3	0.7	0.3	
0	40	20	10	
50	40	20	10	
100	40	20	10	
150	40	20	8	
200	35	18	5	
250	10	6	3	

Lead 3

Orientation	Horizontal			Vertical
	Acceleration (G)			
Speed (mm/s)	0.3	0.7	0.3	
0	40	25	12.5	
25	40	25	12.5	
50	40	25	12.5	
75	40	25	12	
100	40	25	9	
125	40	25	5	

Stroke and maximum speed

Lead (mm)	Energy-saving mode	50-200 (per 50mm)	250 (mm)	300 (mm)
		20	Disabled	800
	Enabled	640		
12	Disabled	700	547	
	Enabled	500		
6	Disabled	450	376	268
	Enabled	250		
3	Disabled	255	186	133
	Enabled	125		

(Unit is mm/s)

Correlation between push force and current limit value

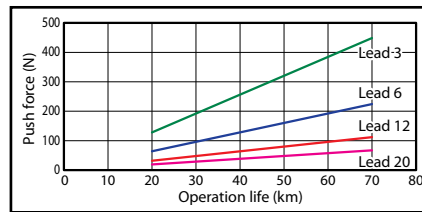

Dimensions

- *1 The actuator cable length of 5m is selectable as an option.
- *2 The interface box terminal shown inside the broken line is not dust-proof treated.
- *3 The total length of actuator cable and the power I/O cable should be under 10m.
- *4 When the rod is returning to its home position, please be careful of interference from surrounding objects, as it will travel until it reaches the M.E.
- *5 The direction of width across flats varies depending on the product. This flat cannot be used for reference plane.

CAD drawings can be downloaded from our website.

www.intelligentactuator.com

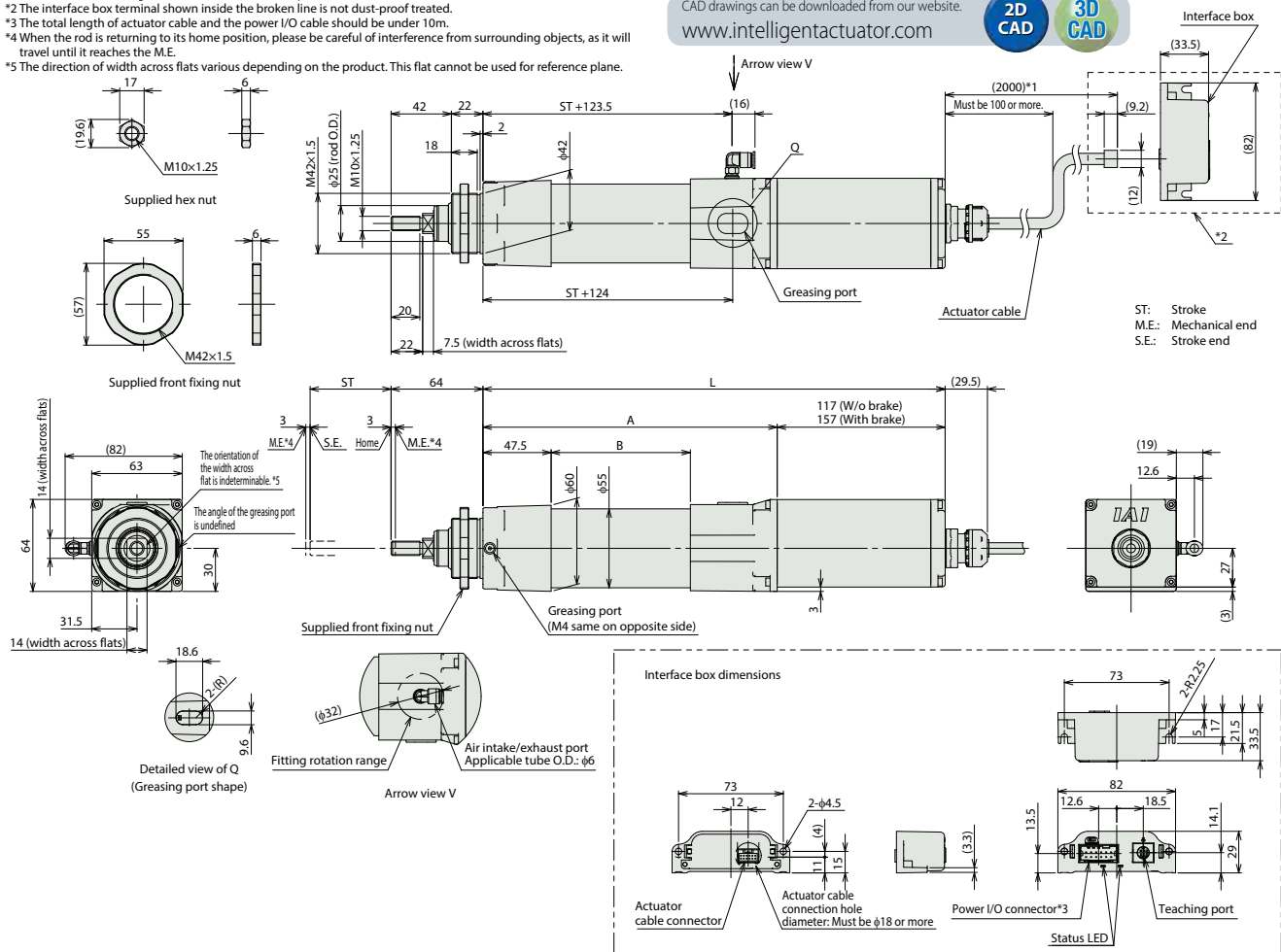

■ Dimensions by stroke

L	Stroke		50	100	150	200	250	300
		Without brake	With brake	322	372	422	472	522
	A	B	362	412	462	512	562	612
			205	255	305	355	405	455
			97	147	197	247	297	347

■ Mass by stroke

Weight (kg)	Stroke		50	100	150	200	250	300
		Without brake	With brake	1.8	2.0	2.2	2.4	2.6
			2.1	2.3	2.5	2.7	2.9	3.1

Applicable controller

(Note) The EC series is equipped with a built-in controller. Please refer to P116 for details.

EC-R7□W

Dust/Splash-proof

Coupled Motor

Body width 70 mm

24v Stepper motor

Model Specification Items

EC — **R7** **W**

Series — Type — Lead — Specification

S	24mm	W	Dust/Splash-proof
H	16mm		
M	8mm		
L	4mm		

Stroke

50	50mm
1	
300	300mm (per 50mm)

Cable Length

With terminal block type connector	
0	
1	1m
1	
8	8m

Options

Refer to Options below.

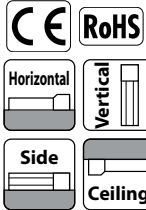

- POINT Selection Notes**
- (1) The actuator specifications display the payload's maximum value, but it will vary depending on the acceleration and speed. Please refer to "Table of Payload by Speed/Acceleration" for more details.
 - (2) The value of the horizontal payload assumes that there is an external guide. Beware that the rotation stop can be damaged when an external force is applied to the rod from any direction other than the moving direction.
 - (3) When performing a push-motion operation, please refer to the "Correlation between push force and current limit value." Push force is only a guide. Please refer to P115 for details.
 - (4) Depending on the ambient operating temperature, duty control is necessary. Please refer to P115 for details.
 - (5) Interface box is not processed for dust- and splash-proof. Install it where there is no water splash.
 - (6) Special attention needs to be paid to the mounting orientation. Please refer to P33 for details.

Stroke			
Stroke (mm)	EC-R7□W	Stroke (mm)	EC-R7□W
50	○	200	○
100	○	250	○
150	○	300	○

Cable Length	
Cable code	Cable length
0	No cable (with connector)
1 ~ 3	1 ~ 3m
4 ~ 5	4 ~ 5m
6 ~ 10	6 ~ 10m

(Note) Select the actuator cable and the power supply I/O cable so that their total length is under 10m.
 (Note) Robot cables.

Options		
Name	Option code	Reference page
Actuator cable length 5m	AC5	See P.101
Brake	B	See P.101
Flange (front)	FL	See P.102
Foot bracket	FT	See P.103
Tip adapter (female screw)	NFA	See P.106
Non-motor end specification	NM	See P.108
PNP specification	PN	See P.108
Split motor and controller power supply specification	TMD2	See P.109
Battery-less absolute encoder	WA	See P.109
Wireless communication specification	WL	See P.109
Wireless axis-operation specification	WL2	See P.109

Main specifications

Item		Description				
Lead	Ball screw lead (mm)	24	16	8	4	
Horizontal	Payload	Max. payload (kg) (energy-saving disabled)	20	50	60	80
		Max. payload (kg) (energy-saving enabled)	18	40	50	55
	Speed/acceleration/deceleration	Max. speed (mm/s)	860	700	350	175
		Min. speed (mm/s)	30	20	10	5
		Rated acceleration/deceleration (G)	0.3	0.3	0.3	0.3
Vertical	Payload	Max. payload (kg) (energy-saving disabled)	3	8	18	19
		Max. payload (kg) (energy-saving enabled)	3	5	17.5	19
	Speed/acceleration/deceleration	Max. speed (mm/s)	640	560	350	175
		Min. speed (mm/s)	30	20	10	5
		Rated acceleration/deceleration (G)	0.3	0.3	0.3	0.3
Push force	Max. acceleration/deceleration (G)	0.5	0.5	0.5	0.5	
	Pushing max. thrust force (N)*	182	273	547	1094	
Brake	Pushing max. speed (mm/s)	20	20	20	20	
	Brake holding specification	Non-excitation actuating solenoid brake				
Stroke	Brake holding force (kgf)	3	8	18	19	
	Min. stroke (mm)	50	50	50	50	
	Max. stroke (mm)	300	300	300	300	
	Stroke pitch (mm)	50	50	50	50	

* Speed limitation applies to push motion. See the manual or contact IAI.

Item	Description	
Driving system	Ball screw φ12mm, Rolling C10	
Positioning repeatability	±0.05mm	
Lost motion	-	
Main material	Rod	Material: Aluminum, White alumite treatment
	Frame	Material: Aluminum, Black alumite treatment
	Dust seal	Rubber (NBR)
	Actuator cable	Polyvinyl chloride (PVC)
Rod non-rotation accuracy (Note 1)	±1.5 degree	
Allowable load and torque on the rod tip.	0.5N·m	
Ambient operation temperature/humidity	0~40°C, 85%RH or less (Non-condensing)	
Degree of protection	IP67	
Vibration & shock resistance	4.9m/s ² 100Hz or less	
Overseas standards	CE marking, RoHS (Restriction of Hazardous Substances)	
Motor type	Stepper motor	
Encoder type	Incremental / battery-less absolute	
Number of encoder pulses	800 pulse/rev	

(Note 1) The rod tip displacement angle (initial reference value) when allowable static torque is applied on rod tip when most of the rod is in the body.

Table of Payload by Speed/Acceleration

Setting for energy-saving disabled Unit for payload is kg. Operations on the blank locations are not possible.

Orientation	Acceleration (G)					
	0.3	0.5	0.7	1	0.3	0.5
Speed (mm/s)						
0	20	18	15	12	3	3
200	20	18	15	12	3	3
400	20	14	12	8	3	3
420	17	12	10	6	3	3
600	14	6	5	4	3	2
640	5	3	2	1.5	2	1
800	5	1	1			
860	2	0.5				

Orientation	Acceleration (G)					
	0.3	0.5	0.7	1	0.3	0.5
Speed (mm/s)						
0	50	40	35	30	8	8
140	50	40	35	30	8	8
280	50	35	25	20	7	7
420	25	18	14	10	4.5	4
560	10	5	3	2	2	1
700	2					

Orientation	Acceleration (G)					
	0.3	0.5	0.7	1	0.3	0.5
Speed (mm/s)						
0	60	50	45	40	18	18
70	60	50	45	40	18	18
140	60	50	45	40	16	12
210	60	40	31	26	10	9
280	34	20	15	11	5	4
350	12	4	1		2	1

Orientation	Acceleration (G)					
	0.3	0.5	0.7	1	0.3	0.5
Speed (mm/s)						
0	80	70	65	60	19	19
35	80	70	65	60	19	19
70	80	70	65	60	19	19
105	80	60	50	40	18	18
140	50	30	20	15	12	10
175	15				2	

■ Setting for energy-saving enabled Unit for payload is kg. Operations on the blank locations are not possible.

Lead 24

Orientation	Horizontal			Vertical
	Acceleration (G)			
Speed (mm/s)	0.3	0.7	0.3	
0	18	9.5	3	
200	18	9.5	3	
400	11	6	1.5	
420	10	5		
600	1			

Lead 16

Orientation	Horizontal			Vertical
	Acceleration (G)			
Speed (mm/s)	0.3	0.7	0.3	
0	40	25	5	
140	40	25	5	
280	18	12	2	
420	1.5	1		

Lead 8

Orientation	Horizontal			Vertical
	Acceleration (G)			
Speed (mm/s)	0.3	0.7	0.3	
0	50	30	17.5	
70	50	30	17.5	
140	50	30	7	
210	14	7	2	

Lead 4

Orientation	Horizontal			Vertical
	Acceleration (G)			
Speed (mm/s)	0.3	0.7	0.3	
0	55	50	19	
35	55	50	19	
70	55	50	13	
105	30	15	2	

Stroke and maximum speed

Lead (mm)	Energy-saving mode	50-300 (per 50mm)
24	Disabled	860<640>
	Enabled	630<420>
16	Disabled	700<560>
	Enabled	420<280>
8	Disabled	350
	Enabled	210
4	Disabled	175
	Enabled	105

(Unit is mm/s)

Correlation between push force and current limit value

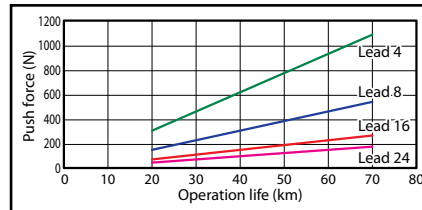

Dimensions

- *1 The actuator cable length of 5m is selectable as an option.
- *2 The interface box terminal shown inside the broken line is not dust-proof treated.
- *3 The total length of actuator cable and the power I/O cable should be under 10m.
- *4 When the rod is returning to its home position, please be careful of interference from surrounding objects, as it will travel until it reaches the M.E.
- *5 The direction of width across flats varies depending on the product. This flat cannot be used for reference plane.

CAD drawings can be downloaded from our website.

www.intelligentactuator.com

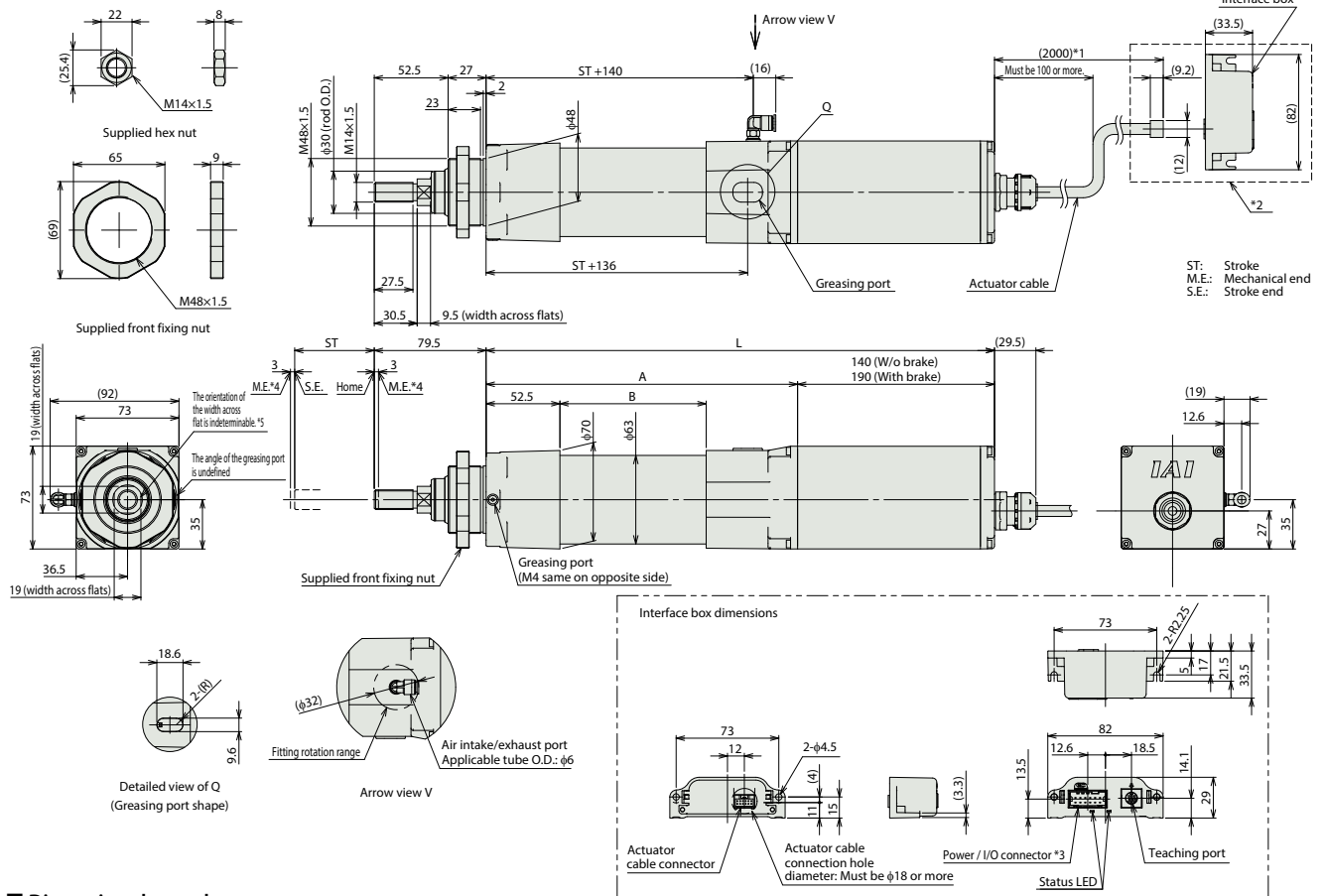

■ Dimensions by stroke

L	Stroke	50	100	150	200	250	300
	Without brake	361.5	411.5	461.5	511.5	561.5	611.5
With brake	411.5	461.5	511.5	561.5	611.5	661.5	
A	221.5	271.5	321.5	371.5	421.5	471.5	
B	104	154	204	254	304	354	

■ Mass by stroke

Weight (kg)	Stroke	50	100	150	200	250	300
	Without brake	3.6	3.8	4.0	4.2	4.4	4.6
With brake	4.2	4.4	4.6	4.8	5.0	5.2	

Applicable controller

(Note) The EC series is equipped with a built-in controller. Please refer to P116 for details.

EC-RR6□W

Dust/Splash-proof

Coupled Motor

Body width 60 mm

24v Stepper motor

Model Specification Items

EC	RR6		W			
Series	Type	Lead	Specification	Stroke	Cable Length	Options
		S 20mm H 12mm M 6mm L 3mm	W Dust/Splash-proof	65 115 165 65mm 315mm (per 50mm)	0 1 2 8 With terminal block type connector 1m 1 8m	Refer to Options below.

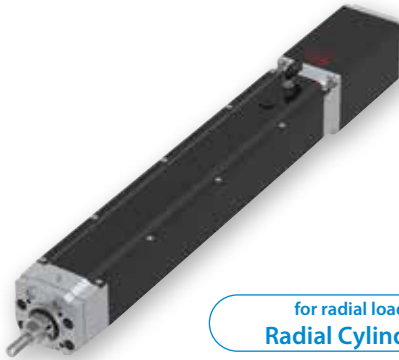
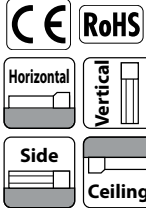

- POINT Selection Notes**
- (1) The actuator specifications display the payload's maximum value, but when energy-saving is activated, the specifications will change. Please refer to "Table of Payload by Speed/Acceleration" for more details.
 - (2) The radial cylinder is equipped with a guide. Refer to P111 for details of the radial load applied to the rod.
 - (3) The horizontal payload assumes the use of an external guide.
 - (4) When performing a push-motion operation, please refer to the "Correlation diagram between pushing force and current limit value." push force is only a guide.
 - (5) Depending on the ambient operating temperature, duty control is necessary. Please refer to P115 for cautions.
 - (6) The interface box is not treated for dust- and splash-proof. Please use it where there is no splash of water.
 - (7) Special attention needs to be paid to the mounting orientation. Please refer to P33 for details.

Stroke			
Stroke (mm)	EC-RR6□W	Stroke (mm)	EC-RR6□W
65	○	215	○
115	○	265	○
165	○	315	○

Cable Length	
Cable code	Cable length
0	No cable (with connector)
1 ~ 3	1 ~ 3m
4 ~ 5	4 ~ 5m
6 ~ 10	6 ~ 10m

(Note) Please select the actuator cable and power-I/O cable so that their total length is 10m or less.
(Note) Robot cable.

Option		
Name	Option code	Reference page
Actuator cable length 5m	AC5	See P.101
Actuator cable length 2m (Fluororubber cover specification) (Note 1)	ACF2	See P.101
Actuator cable length 5m (Fluororubber cover specification) (Note 1)	ACF5	See P.101
Brake	B	See P.101
Tip adaptor (flange)	FFA	See P.101
Flange (front)	FL	See P.102
Foot bracket	FT	See P.103
Specified grease applied specification	G5	See P.105
Tip adaptor (female screw)	NFA	See P.106
Non-motor end specification	NM	See P.108
PNP specification	PN	See P.108
Fluororubber seal specification (Note 1)	SLF	See P.109
Split motor and controller power supply specification	TMD2	See P.109
Battery-less absolute encoder specification	WA	See P.109
Wireless communication specification	WL	See P.109
Wireless axis-operation specification	WL2	See P.109

(Note 1) When selecting the change of the actuator cable length (fluororubber cover specification) (ACF2/ACF5), a fluororubber seal specification (SLF) is also supplied. Therefore, either one is selectable. Therefore, either one is selectable.

Main specifications

Item		Description				
Lead	Ball screw lead (mm)	20	12	6	3	
	Payload	Max. payload (kg) (energy-saving disabled)	6	25	40	60
		Max. payload (kg) (energy-saving enabled)	6	25	40	40
Horizontal	Speed/Acceleration/Deceleration	Max. speed (mm/s)	800	700	450	225
		Min. speed (mm/s)	25	15	8	4
		Rated acceleration/deceleration (G)	0.3	0.3	0.3	0.3
		Max. acceleration/deceleration (G)	1	1	1	1
		Max. payload (kg) (energy-saving disabled)	1.5	4	10	12.5
Vertical	Payload	Max. payload (kg) (energy-saving enabled)	1	4	10	12.5
		Speed/Acceleration/Deceleration	Max. speed (mm/s)	800	700	450
Min. speed (mm/s)	25		15	8	4	
Rated acceleration/deceleration (G)	0.3		0.3	0.3	0.3	
Max. acceleration/deceleration (G)	0.5		0.5	0.5	0.5	
Max. thrust force when pushing (N)*	67		112	224	449	
Push force	Max. speed when pushing (mm/s)	20	20	20	20	
		Brake	Brake specification	Non-excitation actuating solenoid brake		
Brake holding force (kgf)	1.5		4	10	12.5	
Min. stroke (mm)	65		65	65	65	
Max. stroke (mm)	315		315	315	315	
Stroke	Stroke pitch (mm)	50	50	50	50	

Item	Description	
Driving system	Ball screw φ10mm, Rolling C10	
Positioning repeatability	±0.05mm	
Lost motion	-	
Linear guide	Linear motion infinite circulating type	
Main material	Rod	φ25mm, material: aluminum hard-alumite treated
	Frame	Material: Aluminum, Black alumite treated
	Dust seal	Rubber (NBR)
Actuator cable	Polyvinyl chloride (PVC)	
Rod rotational accuracy (Note 2)	0 degree	
Ambient operation temperature/humidity	0 to 40°C, RH 85% or less (Non-condensing)	
Degree of protection	IP67	
Vibration & shock resistance	4.9m/s ² 100Hz or less	
Overseas standards	CE marking, RoHS	
Motor type	Stepper motor	
Encoder type	Incremental / battery-less absolute	
Number of encoder pulses	800 pulse/rev.	

(Note 2) Displacement angle in the rod rotational direction when no load is applied.

* Speed limitation applies to push motion. See the manual or contact IAI.

Table of Payload by Speed/Acceleration

Energy-saving disabled Unit for payload is kg. Operations are not possible in the blank cells.

Orientation	Lead 20					
	Acceleration (G)					
Speed (mm/s)	0.3	0.5	0.7	1	0.3	0.5
0	6	6	5	5	1.5	1.5
160	6	6	5	5	1.5	1.5
320	6	6	5	3	1.5	1.5
480	6	6	5	3	1.5	1.5
640	6	4	3	2	1.5	1.5
800	4	3		1	1	

Orientation	Lead 12					
	Acceleration (G)					
Speed (mm/s)	0.3	0.5	0.7	1	0.3	0.5
0	25	18	16	12	4	4
100	25	18	16	12	4	4
200	25	18	16	10	4	4
400	20	14	10	6	4	4
500	15	8	6	4	3.5	3
700	6	2			2	1

Orientation	Lead 6					
	Acceleration (G)					
Speed (mm/s)	0.3	0.5	0.7	1	0.3	0.5
0	40	35	30	25	10	10
50	40	35	30	25	10	10
100	40	35	30	25	10	10
200	40	30	25	20	10	10
250	40	27.5	22.5	18	9	8
350	30	14	12	10	5	5
400	18	10	6	5	3	3
450	8	3			2	1

Orientation	Lead 3					
	Acceleration (G)					
Speed (mm/s)	0.3	0.5	0.7	1	0.3	0.5
0	60	50	45	40	12.5	12.5
50	60	50	45	40	12.5	12.5
100	60	50	45	40	12.5	12.5
125	60	50	40	30	10	10
175	40	35	25	20	6	5
200	35	30	20	14	5	4.5
225	16	16	10	6	5	4

■ Energy-saving enabled Unit for payload is kg.

Lead 20

Orientation	Horizontal			Vertical
	Acceleration (G)			
Speed (mm/s)	0.3	0.7	0.3	
0	6	5	1	
160	6	5	1	
320	6	5	1	
480	4	3	1	
640	3	1	0.5	

Lead 12

Orientation	Horizontal			Vertical
	Acceleration (G)			
Speed (mm/s)	0.3	0.7	0.3	
0	25	10	4	
100	25	10	4	
200	25	10	4	
300	20	8	3	
400	10	5	2	
500	5	2	1	

Lead 6

Orientation	Horizontal			Vertical
	Acceleration (G)			
Speed (mm/s)	0.3	0.7	0.3	
0	40	20	10	
50	40	20	10	
100	40	20	10	
150	40	20	8	
200	35	18	5	
250	10	6	3	

Lead 3

Orientation	Horizontal			Vertical
	Acceleration (G)			
Speed (mm/s)	0.3	0.7	0.3	
0	40	25	12.5	
50	40	25	12.5	
75	40	25	12	
100	40	25	9	
125	40	25	5	

Stroke and Max. Speed

Lead (mm)	Energy-saving	65-215 (every 50mm)	265 (mm)	315 (mm)
20	Disabled	800		
	Enabled	640		
12	Disabled	700	660	480
	Enabled	500		
6	Disabled	450	325	235
	Enabled	250		
3	Disabled	225	160	115
	Enabled	125		

(Unit is mm/s)

Correlation between push force and current limit value

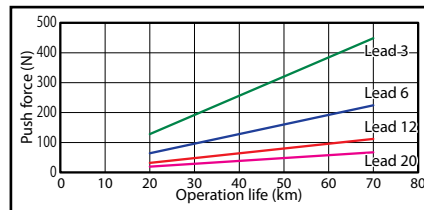

Rod deflection

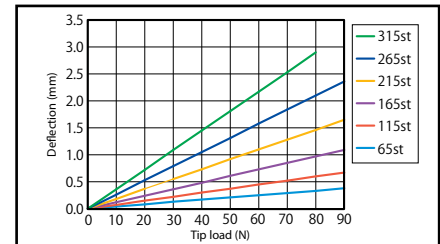

Dimensions

- *1 A pigtail length of 5m is selectable as an option.
- *2 The connecting part of the interface box shown inside the broken line is not dust- and splash-proof treated.
- *3 Please select the actuator cable and power-I/O cable so that their total length is 10m or less.
- *4 When the rod is returning to its home position, please be careful of interference from surrounding objects, as it will travel until it reaches the M.E.
- *5 The direction of width across flats varies depending on the product. This flat cannot be used for reference plane.

CAD drawings can be downloaded from our website.

www.intelligentactuator.com



ST: Stroke
M.E.: Mechanical end
S.E.: Stroke end

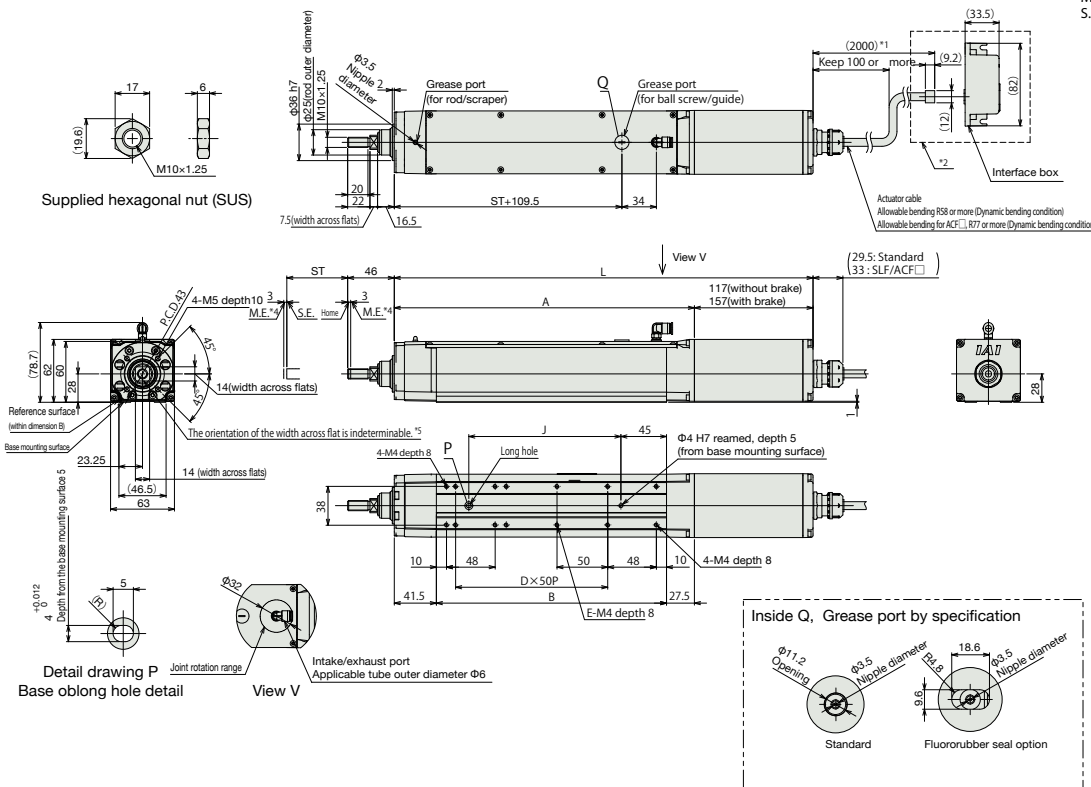

■ Dimensions by stroke

Stroke	65	115	165	215	265	315	
L	Without brake	363	413	463	513	563	613
	With brake	403	453	503	553	603	653
A	246	296	346	396	446	496	
B	177	227	277	327	377	427	
D	2	3	4	5	6	7	
E	4	6	8	10	12	14	
J	100	150	200	250	300	350	

■ Weight by Stroke

Stroke	65	115	165	215	265	315	
Weight (kg)	Without brake	2.4	2.7	3.1	3.4	3.7	4.1
	With brake	2.7	3	3.3	3.7	4	4.3

Applicable controller

(Note) The EC series is equipped with a built-in controller. Please refer to P117 for details.

EC-RR7□W

Dust/Splash-proof

Coupled Motor

Body width 70 mm

24v Stepper motor

Model Specification Items

EC	—	RR7	<input type="text"/>	W	—	<input type="text"/>	—	<input type="text"/>	—	<input type="text"/>
Series		Type	Lead	Specification		Stroke		Cable length		Option
			S 24mm H 16mm M 8mm L 4mm	W Dust/Splash-proof		65 115 165	65mm / 315mm (every 50mm)	0 1 4 8	With terminal block type connector 1m / 8m	See the option price list below

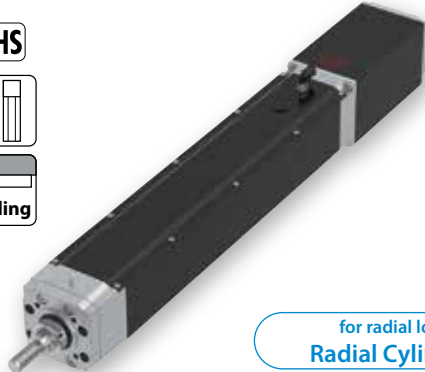
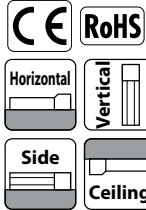

for radial load
Radial Cylinder*



- (1) The actuator specifications display the payload's maximum value, but when energy-saving is activated, the specifications will change. Please refer to "Table of Payload by Speed/Acceleration" for more details.
- (2) The radial cylinder is equipped with a guide. Refer to P111 for details of the radial load applied to the rod.
- (3) The horizontal payload assumes the use of an external guide.
- (4) When performing a push-motion operation, please refer to the "Correlation diagram between pushing force and current limit value." push force is only a guide.
- (5) Depending on the ambient operating temperature, duty control is necessary. Please refer to P115 for cautions.
- (6) The interface box is not treated for dust- and splash-proof. Please use it where there is no splash of water.
- (7) Special attention needs to be paid to the mounting orientation. Please refer to P33 for details.

Stroke			
Stroke (mm)	EC-RR7□W	Stroke (mm)	EC-RR7□W
65	○	215	○
115	○	265	○
165	○	315	○

Cable Length	
Cable code	Cable length
0	No cable (with connector)
1 ~ 3	1 ~ 3m
4 ~ 5	4 ~ 5m
6 ~ 8	6 ~ 8m

(Note) Please select the actuator cable and power-I/O cable so that their total length is 10m or less.
(Note) Robot cable.

Option		
Name	Option code	Reference page
Actuator cable length 5m	AC5	See P.101
Actuator cable length 2m (Fluororubber cover specification) (Note 1)	ACF2	See P.101
Actuator cable length 5m (Fluororubber cover specification) (Note 1)	ACF5	See P.101
Brake	B	See P.101
Tip adaptor (flange)	FFA	See P.101
Flange (front)	FL	See P.102
Foot bracket	FT	See P.103
Specified grease applied specification	G5	See P.105
Tip adaptor (female screw)	NFA	See P.106
Non-motor end specification	NM	See P.108
PNP specification	PN	See P.108
Fluororubber seal specification (Note 1)	SLF	See P.109
Split motor and controller power supply specification	TMD2	See P.109
Battery-less absolute encoder specification	WA	See P.109
Wireless communication specification	WL	See P.109
Wireless axis-operation specification	WL2	See P.109

(Note 1) When selecting the change of the actuator cable length (fluororubber cover specification) (ACF2/ACF5), a fluororubber seal specification (SLF) is also supplied. Therefore, either one is selectable. Therefore, either one is selectable.

Main specifications

Item		Description				
Lead	Ball screw lead (mm)	24	16	8	4	
Horizontal	Payload	Max. payload (kg) (energy-saving disabled)	20	50	60	80
		Max. payload (kg) (energy-saving enabled)	18	40	50	55
		Max. speed (mm/s)	860	700	350	175
	Speed/Acceleration/Deceleration	Min. speed (mm/s)	30	20	10	5
Rated acceleration/deceleration (G)		0.3	0.3	0.3	0.3	
Max. acceleration/deceleration (G)		1	1	1	1	
Max. payload (kg) (energy-saving disabled)		3	8	18	19	
Vertical	Payload	Max. payload (kg) (energy-saving enabled)	3	5	17.5	19
		Max. speed (mm/s)	640	560	350	175
		Min. speed (mm/s)	30	20	10	5
	Speed/Acceleration/Deceleration	Rated acceleration/deceleration (G)	0.3	0.3	0.3	0.3
Max. acceleration/deceleration (G)		0.5	0.5	0.5	0.5	
Max. thrust force when pushing (N)*		182	273	547	1094	
Max. speed when pushing (mm/s)		20	20	20	20	
Brake	Brake specification	Non-excitation actuating solenoid brake				
	Brake holding force (kgf)	3	8	18	19	
Stroke	Min. stroke (mm)	65	65	65	65	
	Max. stroke (mm)	315	315	315	315	
	Stroke pitch (mm)	50	50	50	50	

Item		Description
Driving system		Ball screw φ12mm, Rolling C10
Positioning repeatability		±0.05mm
Lost motion		-
Linear guide		Linear motion infinite circulating type
	Rod	Φ30mm, material: aluminum hard-alumite treated
Main material	Frame	Material: Aluminum, Black alumite treated
	Dust seal	Rubber (NBR)
	Actuator cable	Polyvinyl chloride (PVC)
Rod rotational accuracy (Note 2)		0 degree
Ambient operation temperature/humidity		0 to 40°C, RH 85% or less (Non-condensing)
Degree of protection		IP67
Vibration & shock resistance		4.9m/s ² 100Hz or less
Overseas standards		CE marking, RoHS
Motor type		Stepper motor
Encoder type		Incremental / battery-less absolute
Number of encoder pulses		800 pulse/rev.

(Note 2) Displacement angle in the rod rotational direction when no load is applied.

* Speed limitation applies to push motion. See the manual or contact IAI.

Table of Payload by Speed/Acceleration

Energy-saving disabled Unit for payload is kg. Operations are not possible in the blank cells.

Lead 24	Orientation	Horizontal						Vertical					
		Acceleration (G)						Acceleration (G)					
Speed (mm/s)		0.3	0.5	0.7	1	0.3	0.5	0.3	0.5	0.7	1	0.3	0.5
0		20	18	15	12	3	3						
200		20	18	15	12	3	3						
400		20	14	12	8	3	3						
420		17	12	10	6	3	3						
600		14	6	5	4	3	2						
640		5	3	2	1.5	2	1						
800		5	1	1									
860		2	0.5										

Lead 16	Orientation	Horizontal						Vertical					
		Acceleration (G)						Acceleration (G)					
Speed (mm/s)		0.3	0.5	0.7	1	0.3	0.5	0.3	0.5	0.7	1	0.3	0.5
0		50	40	35	30	8	8						
140		50	40	35	30	8	8						
280		50	35	25	20	7	7						
420		25	18	14	10	4.5	4						
560		10	5	3	2	2	1						
700		2											

Lead 8	Orientation	Horizontal						Vertical					
		Acceleration (G)						Acceleration (G)					
Speed (mm/s)		0.3	0.5	0.7	1	0.3	0.5	0.3	0.5	0.7	1	0.3	0.5
0		60	50	45	40	18	18						
70		60	50	45	40	18	18						
140		60	50	45	40	16	12						
210		60	40	31	26	10	9						
280		34	20	15	11	5	4						
350		12	4	1		2	1						

Lead 4	Orientation	Horizontal						Vertical					
		Acceleration (G)						Acceleration (G)					
Speed (mm/s)		0.3	0.5	0.7	1	0.3	0.5	0.3	0.5	0.7	1	0.3	0.5
0		80	70	65	60	19	19						
35		80	70	65	60	19	19						
70		80	70	65	60	19	19						
105		80	60	50	40	18	18						
140		50	30	20	15	12	10						
175		15				2							

■ Energy-saving Enabled Unit for payload is kg.

Lead 24

Orientation	Acceleration (G)		
	0.3	0.7	0.3
Speed (mm/s)			
0	18	9.5	3
200	18	9.5	3
420	10	5	1.5
600	1		

Lead 16

Orientation	Acceleration (G)		
	0.3	0.7	0.3
Speed (mm/s)			
0	40	25	5
140	40	25	5
280	18	12	2
420	1.5	1	

Lead 8

Orientation	Acceleration (G)		
	0.3	0.7	0.3
Speed (mm/s)			
0	50	30	17.5
70	50	30	17.5
140	50	30	7
210	14	7	2

Lead 4

Orientation	Acceleration (G)		
	0.3	0.7	0.3
Speed (mm/s)			
0	55	50	19
35	55	50	19
70	55	50	13
105	30	15	2

Stroke and maximum speed

Lead (mm)	Energy-saving mode	65-315 (every 50mm)
24	Disabled	860<640>
	Enabled	630<420>
16	Disabled	700<560>
	Enabled	420<280>
8	Disabled	350
	Enabled	210
4	Disabled	175
	Enabled	105

(Unit is mm/s)

Correlation between push force and current limit value

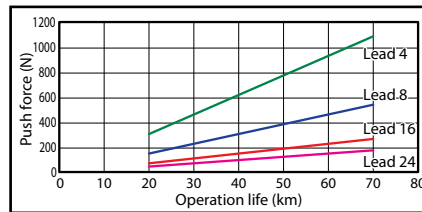

Rod deflection

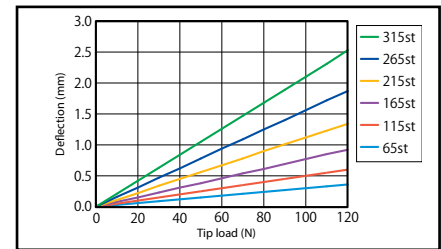

Dimensions

- *1 A pigtail length of 5m is selectable as an option.
- *2 The connecting part of the interface box shown inside the broken line is not dust- and splash-proof treated.
- *3 Please select the actuator cable and power-I/O cable so that their total length is 10m or less.
- *4 When the rod is returning to its home position, please be careful of interference from surrounding objects, as it will travel until it reaches the M.E.
- *5 The direction of width across flats varies depending on the product. This flat cannot be used for reference plane.

CAD drawings can be downloaded from our website.
www.intelligentactuator.com

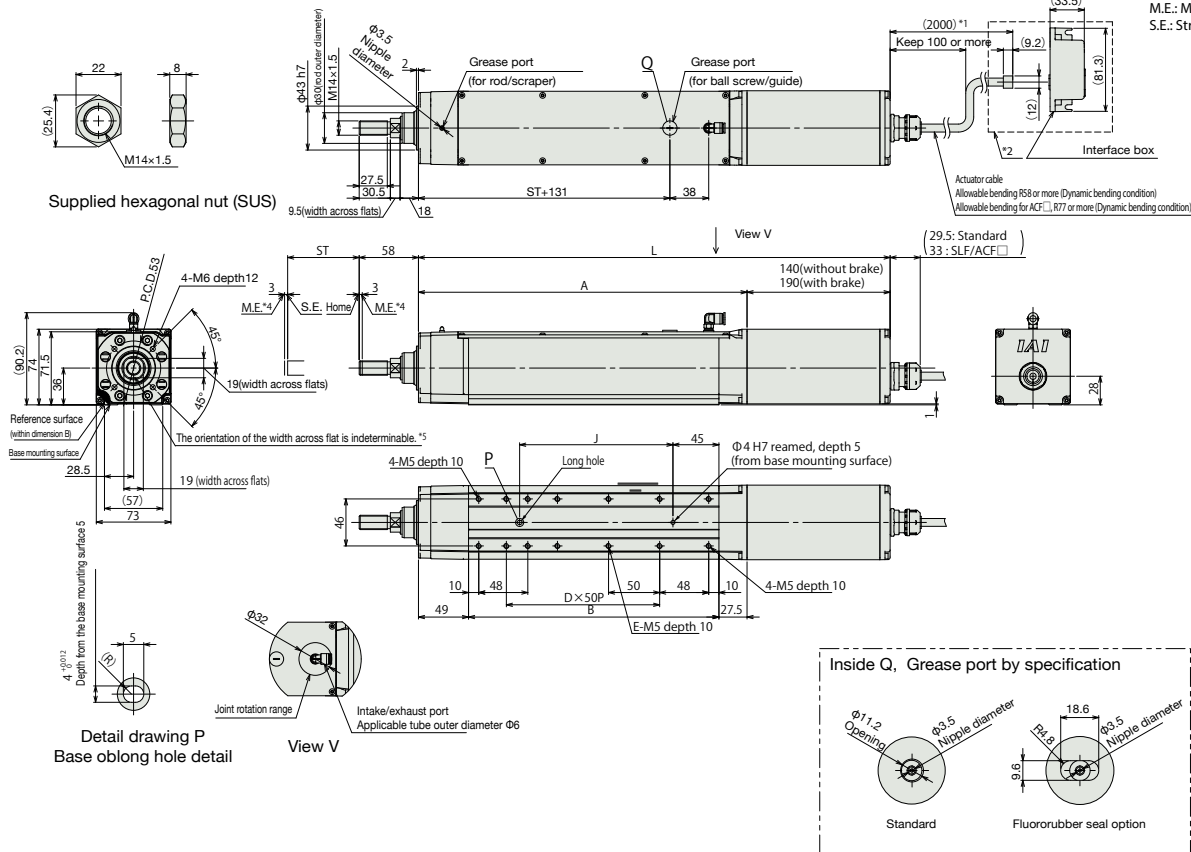

■ Dimensions by stroke

Stroke	65	115	165	215	265	315
L	Without brake	411.5	461.5	511.5	561.5	611.5
	With brake	461.5	511.5	561.5	611.5	661.5
A	271.5	321.5	371.5	421.5	471.5	521.5
B	195	245	295	345	395	445
D	2	3	4	5	6	7
E	4	6	8	10	12	14
J	100	150	200	250	300	350

■ Weight by Stroke

Stroke	65	115	165	215	265	315
Weight (kg)	Without brake	4.7	5.1	6.6	6.1	7
	With brake	5.3	5.7	6.2	6.6	7.1

Applicable controller

(Note) The EC series is equipped with a built-in controller. Please refer to P117 for details.

Options for the ELECYLINDER® series

Actuator pigtail cable length: 5 m

Model **AC5** **Applicable Models** EC-R6□W/R7□W/RR6□W/RR7□W

Description Although the standard length of the actuator pigtail cable of the EC waterproof series is 2m, it can be changed to 5m as an option.
* Make sure that the total length of the actuator pigtail cable and power I/O cable is within 10m.
(When the actuator pigtail cable length 5m (AC5) is selected, the power I/O cable must be 5m or less.)

Actuator pigtail cable length change (fluororubber sheath specification)

Model **ACF2/ACF5** **Applicable Models** EC-R6□W/R7□W/RR6□W/RR7□W

Description The pigtail seal material is changed from NBR (nitrile rubber) to FKM (fluororubber), and the actuator pigtail cable jacket is changed from PVC (poly vinyl chloride) to FKM (fluororubber).
The cable length of ACF2 is 2m and ACF5 is 5m.

Brake

Model **B** **Applicable Models** All Models

Description When the actuator is mounted vertically, this works as a holding mechanism that prevents the slider or rod from falling and damaging any attachments when the power or servo is turned off.

Tip adapter (flange)

Model **FFA** **Applicable Models** EC-RR6 All Models

Description This adapter is used to mount jigs, etc., on the rod tip with four bolts.

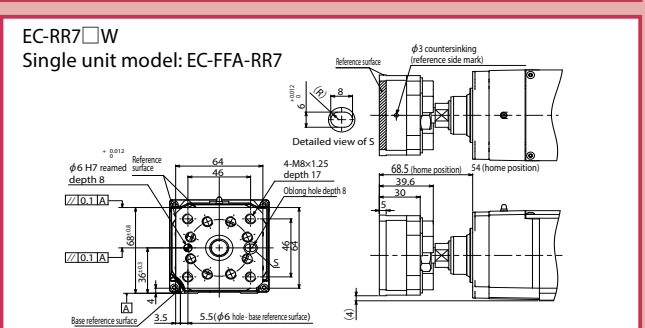
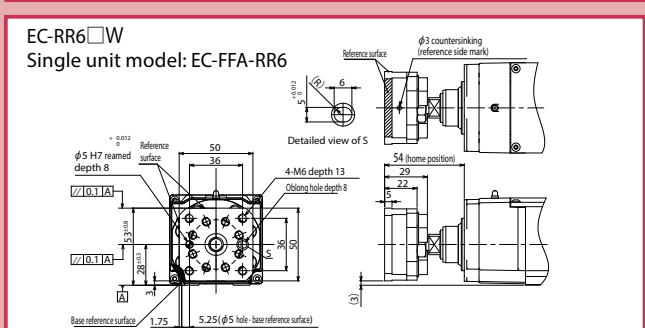
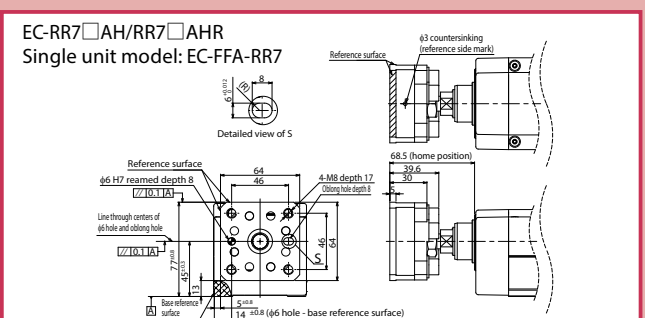
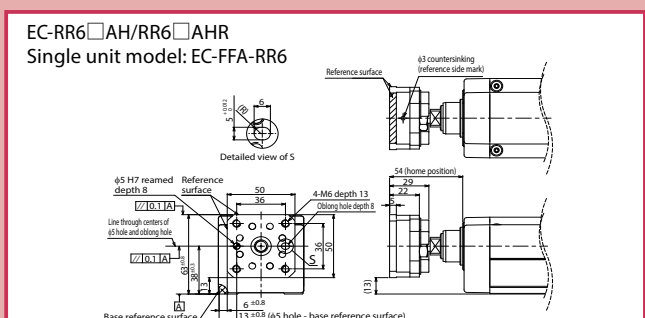
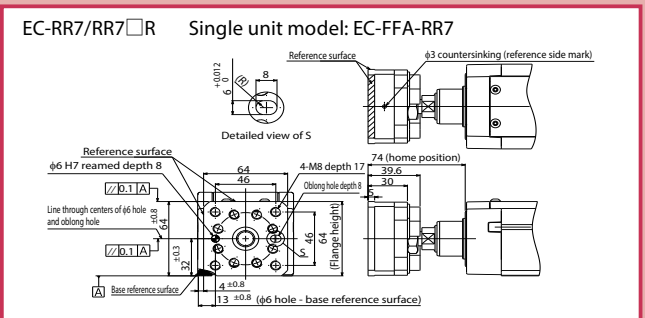
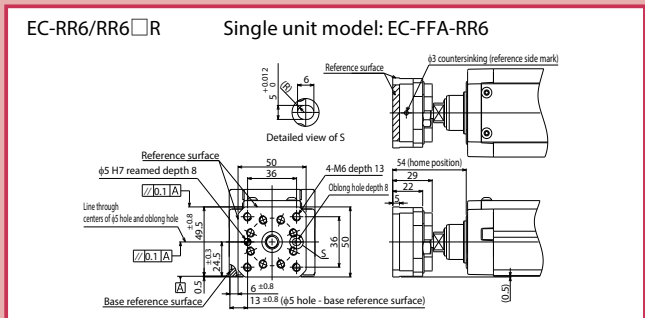
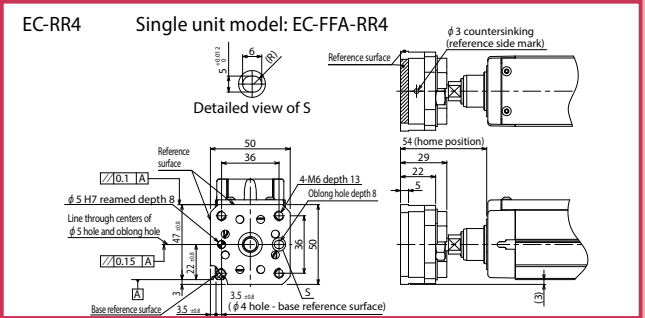
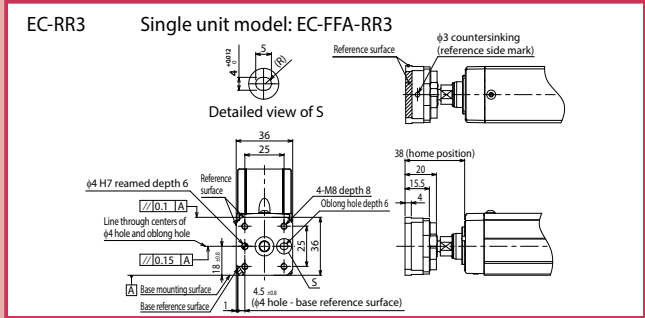

Flange (front)

Model **FL** **Applicable Models** EC-R/RR All models

Description This bracket is used for mounting the actuator body side with bolts.

* Refer to the drawing and mount the part as it is not assembled before shipment.

Note that when this is ordered with the tip adapter "FFA," the flange "FL" is also assembled before shipping.

EC-R6/R6□W Single unit model: EC-FL-R6

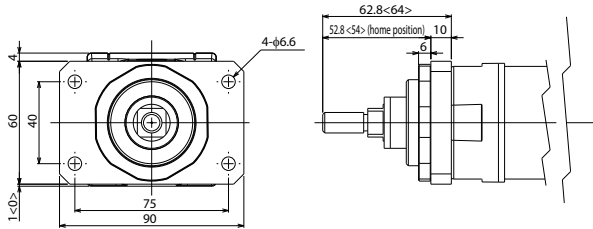

The dimensions in the <> represent water-proof type (R6□W).

EC-R7/R7□W Single unit model: EC-FL-R7

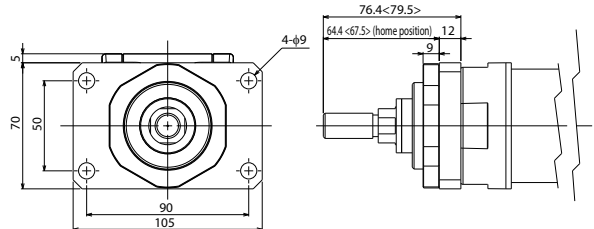

The dimensions in the <> represent water-proof type (R7□W).

EC-RR3 Single unit model: EC-FL-RR3

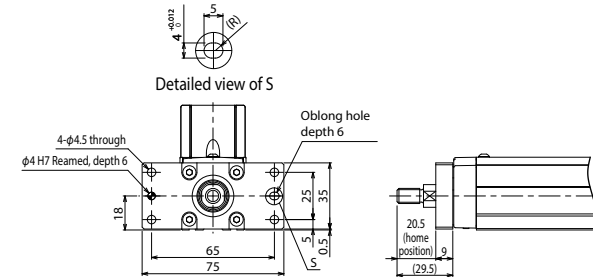

EC-RR4 Single unit model: EC-FL-RR4

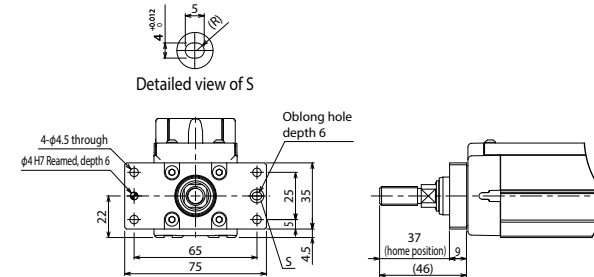

EC-RR6/RR6□R Single unit model: EC-FL-RR6

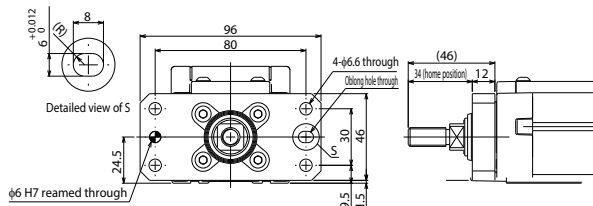

EC-RR7/RR7□R Single unit model: EC-FL-RR7

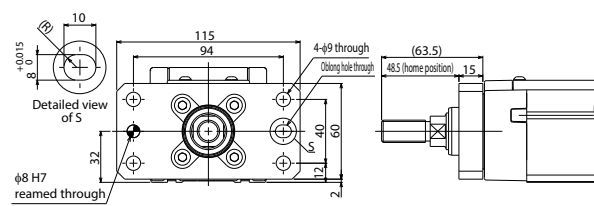

EC-RR6□AH/RR6□AHR Single unit model: EC-FL-RR6

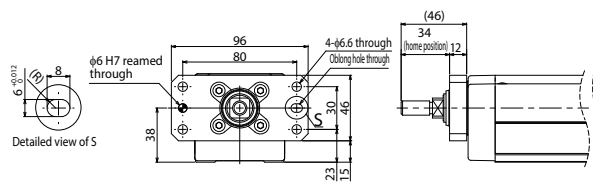

EC-RR7□AH/RR7□AHR Single unit model: EC-FL-RR7

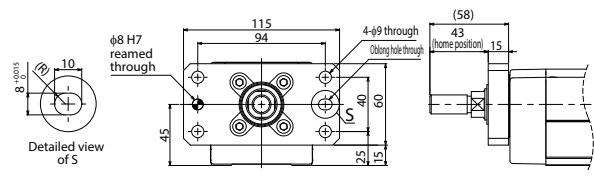

EC-RR6□AH/RR6□W Single unit model: ECW-FL-RR6

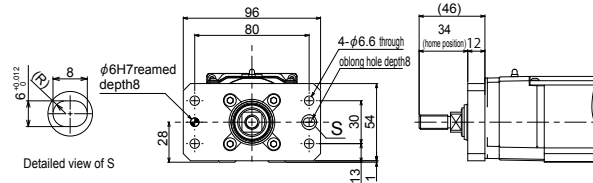

EC-RR7□W Single unit model: ECW-FL-RR7

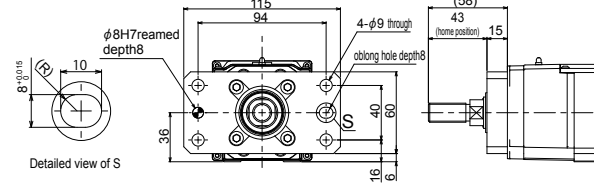

Foot bracket

Model FT **Applicable Models** All models of S/R/RR (except for S6□AH/S7□AH/RR6□AH/RR7□AH).

Description This bracket is used for fixing the actuator body from the top with bolts.
 * Please mount the brackets referring to the drawing as it is not pre-assembled prior to shipment.

EC-S3 Single unit model: EC-FT-SRR3 (2-piece set)

EC-S4 Single unit model: EC-FT-SRR4 (2-piece set)

EC-S6 Single unit model: EC-FTSB

EC-S7 Single unit model: EC-FTSB

EC-S6□R Single unit model: EC-FT-SRR6R

ST	Qty.
50-300	2
350-400	3

EC-S7□R Single unit model: EC-FT-SRR7R

ST	Qty.
50-300	2
350-500	3

EC-S6□AHR Single unit model: EC-FT-SRR6R

ST	Qty.
50-300	2
350-550	3
600-800	4

EC-S7□AHR Single unit model: EC-FT-SRR7R

ST	Qty.
50-300	2
350-550	3
600-800	4

EC-R6/EC-R6□W Single unit model: EC-FT-R6

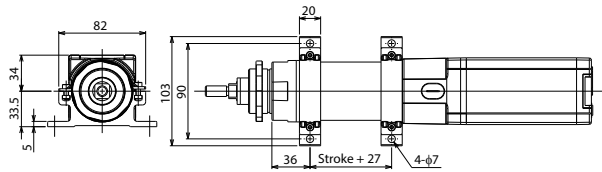

EC-R7/EC-R7□W Single unit model: EC-FT-R7

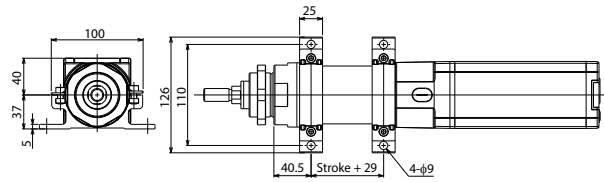

EC-RR3 Single unit model: EC-FT-SRR3 (2-piece set)

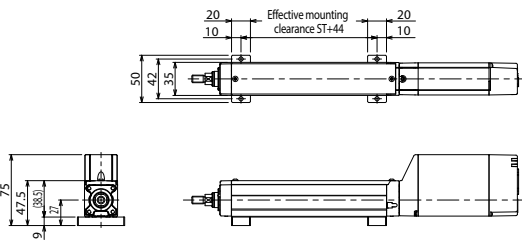

EC-RR4 Single unit model: EC-FT-SRR4 (2-piece set)

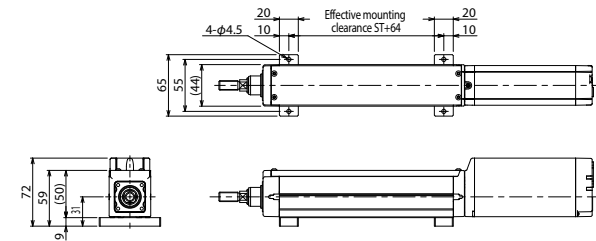

EC-RR6 Single unit model: EC-FTSB

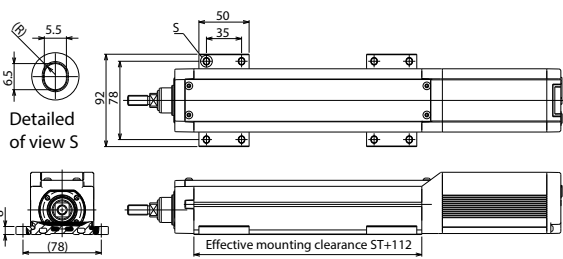

EC-RR7 Single unit model: EC-FTSB-02

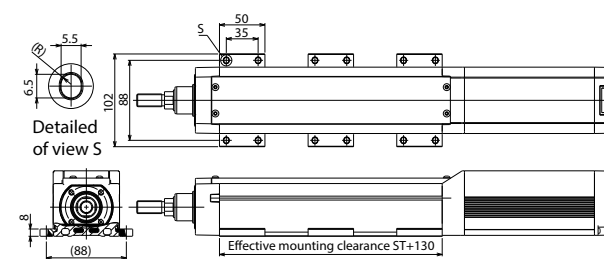

EC-RR6□R Single unit model: EC-FT-SRR6R

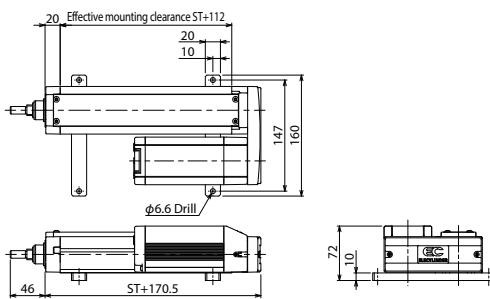

EC-RR7□R Single unit model: EC-FT-SRR7R

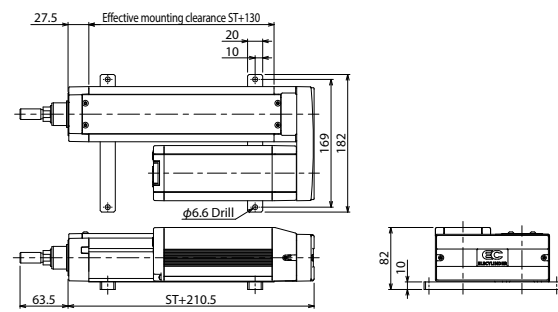

EC-RR6□AHR Single unit model: EC-FT-SRR6R

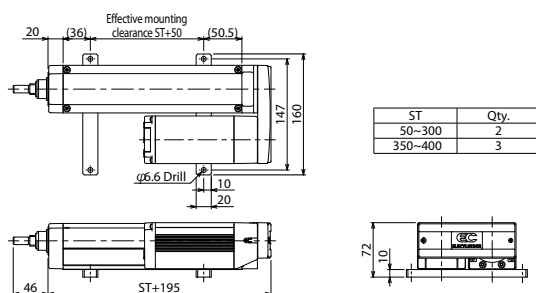

EC-RR7□AHR Single unit model: EC-FT-SRR7R

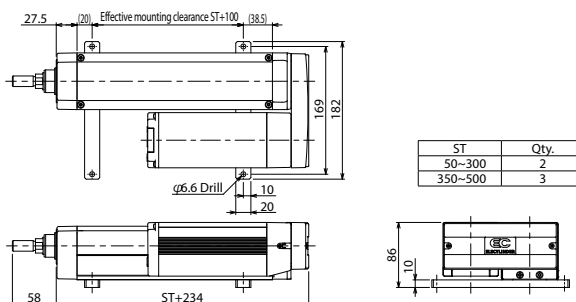

EC-RR6□W Single unit model: ECW-FT-RR6

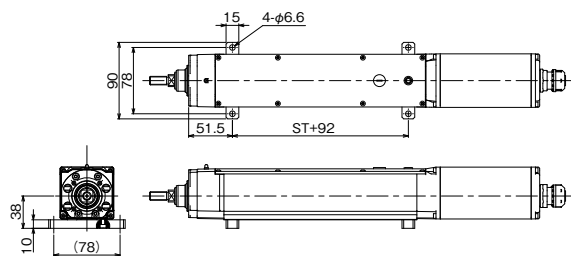

EC-RR7□W Single unit model: ECW-FT-RR7

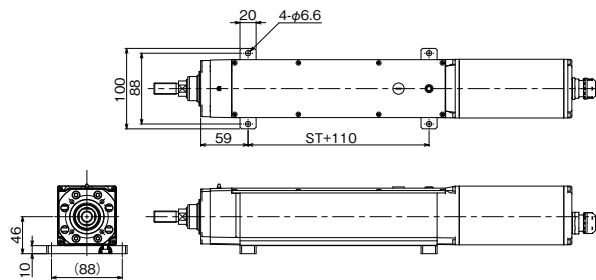

Specified grease applied specification

Model G5 **Applicable Models** EC-R6□W/R7□W/RR6□W/RR7□W

Description The grease put on the ballscrew, linear guide, and rod, is changed to food grade grease (White Alcom).

Guide mounting direction / Table mounting direction

Model GT2 / GT3 / GT4 **Applicable Models** EC-GS4/TC4

Description Select the guide shaft position of EC-GS4 and the table position of EC-TC4.

**Please be sure to select GT2, GT3 or GT4 for the guide mounting direction/table mounting direction.*

EC-GS4

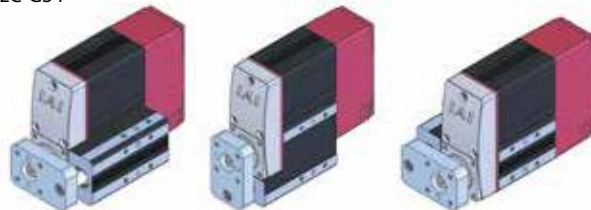

GT2 Guide right mount GT3 Guide bottom mount GT4 Guide left mount

EC-TC4

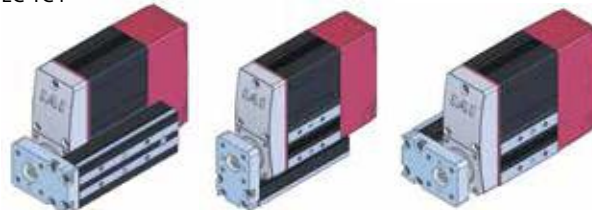

GT2 Table right mount GT3 Table bottom mount GT4 Table left mount

Side-mounted motor direction

Model ML / MR **Applicable Models** Side-mounted motor specification

Description This allows you to specify the direction of the side-mounted motor type. As viewed from the motor-side of the actuator, side-mounting to left is ML and right is MR.

Motor mounting direction change

Model MOB / MOL / MOR / MOT **Applicable Models** EC-S3/S4/RR3/RR4

Description The motor mounting direction can be selected from 4 directions of bottom side / left side / right side / top side. Please be sure to specify one of these options in the model number.

EC-S3



MOB Motor mounting direction change (bottom)



MOL Motor mounting direction change (left)



MOR Motor mounting direction change (right)



MOT Motor mounting direction change (top)

Tip adapter (Internal thread)

Model NFA **Applicable Models** EC-R/RR All models

Description This adapter is used to mount jigs, etc., on the rod tip with one bolt.

* The direction of width across flats varies depending on the product. Those flats cannot be used for reference plane.

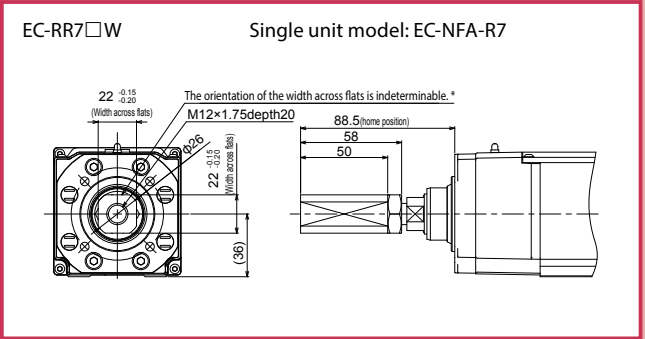
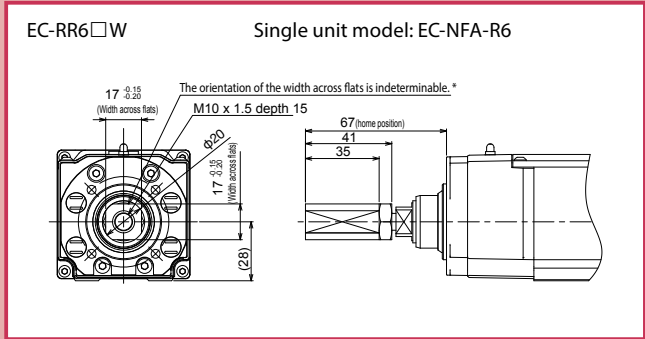
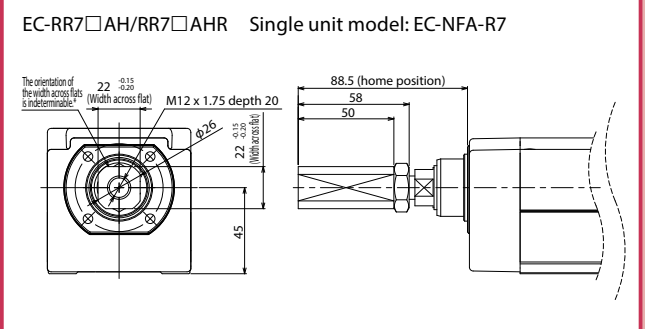
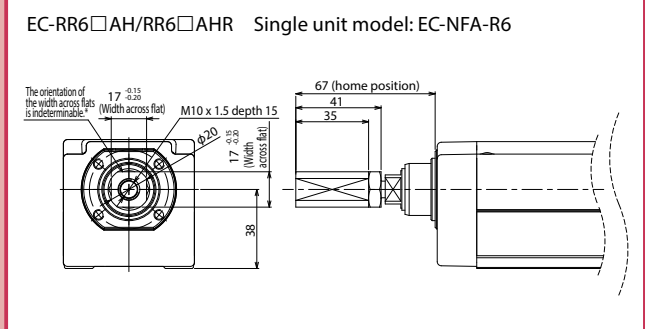
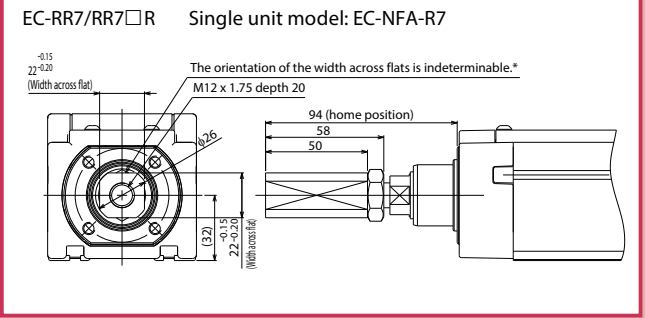
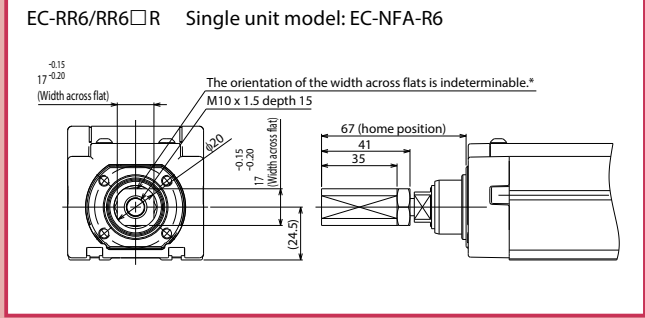
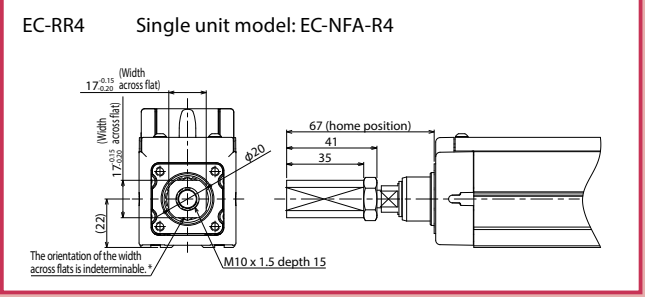
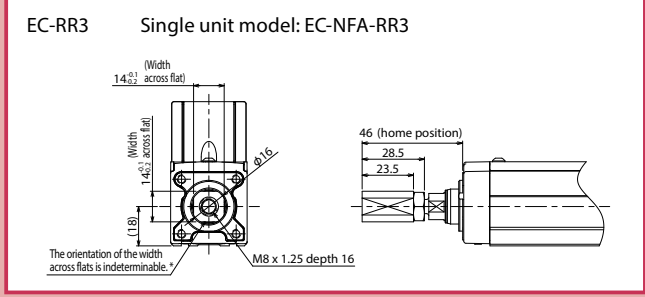
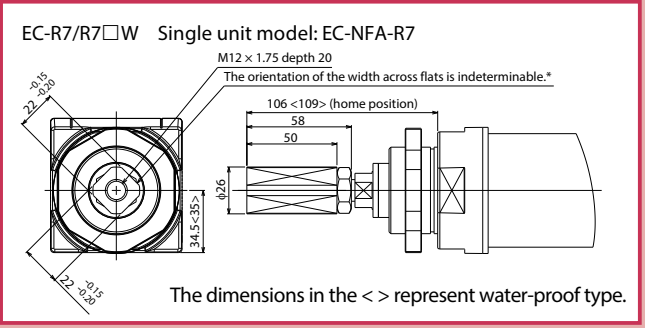
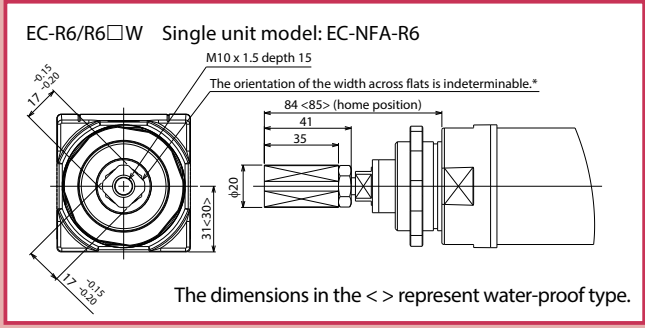

Knuckle joint

Model **NJ** **Applicable Models** EC-RR6/RR7/RR6□AH/RR7□AH/RR6□R/RR7□R/RR6□AHR/RR7□AHR

Description The bracket provides freedom (rotational) to the movement of actuator rod tip when using with a clevis or trunnion brackets. Please use this together with the clevis bracket (QR or QRPB) as a set.

EC-RR6/RR6□R Single unit model: EC-NJ-RR6
 * Not shipped assembled. Refer to the drawing to mount.
 When making adjustments, we recommend that the parallelism fall within the level mentioned on the mechanical drawings provided.

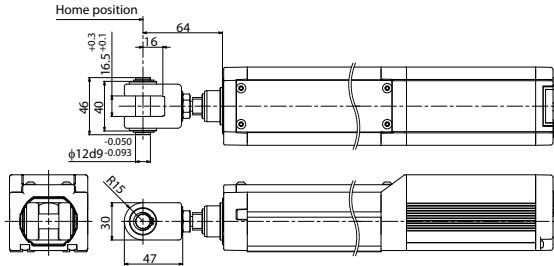

EC-RR7/RR7□R Single unit model: EC-NJ-RR7
 * Not shipped assembled. Refer to the drawing to mount.
 When making adjustments, we recommend that the parallelism fall within the level mentioned on the mechanical drawings provided.

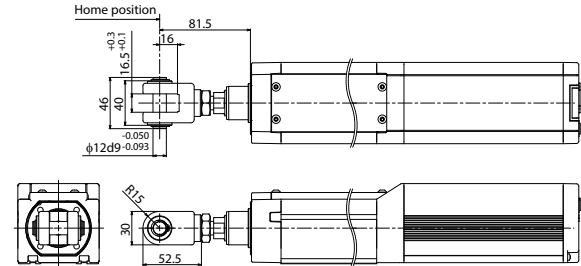

EC-RR6□AH/RR6□AHR Single unit model: EC-NJ-RR6
 * Not shipped assembled. Refer to the drawing to mount.
 When making adjustments, we recommend that the parallelism fall within the level mentioned on the mechanical drawings provided.

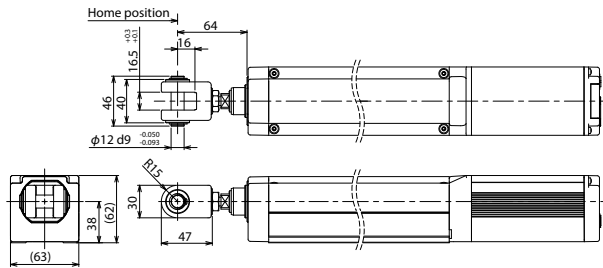

EC-RR7□AH/RR7□AHR Single unit model: EC-NJ-RR7
 * Not shipped assembled. Refer to the drawing to mount.
 When making adjustments, we recommend that the parallelism fall within the level mentioned on the mechanical drawings provided.

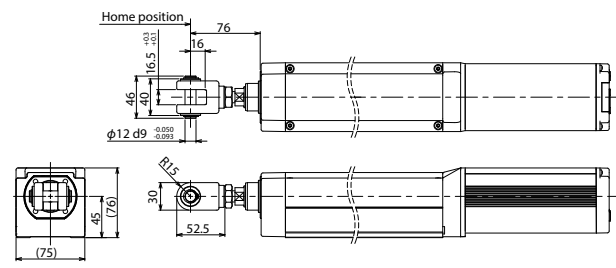

Knuckle joint + oscillation receiving bracket

Model **NJPB** **Applicable Models** EC-RR6/RR7/RR6□AH/RR7□AH/RR6□R/RR7□R/RR6□AHR/RR7□AHR

Description Knuckle joint and oscillation receiving bracket. Please use this together with the clevis bracket (QR or QRPB) as a set.

EC-RR6/RR6□R Single unit model: EC-NJPB-RR6

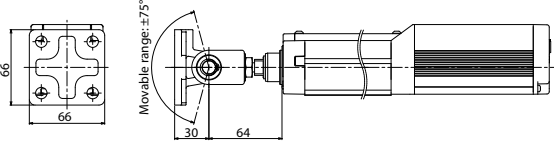

EC-RR7/RR7□R Single unit model: EC-NJPB-RR7

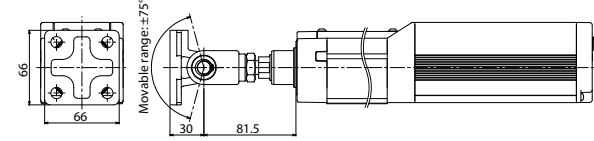

EC-RR6□AH/RR6□AHR Single unit model: EC-NJPB-RR6

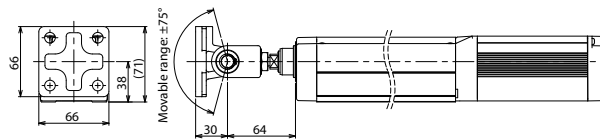

EC-RR7□AH/RR7□AHR Single unit model: EC-NJPB-RR7

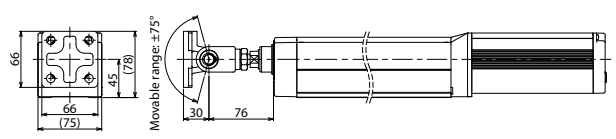

Dimensions of oscillation receiving bracket

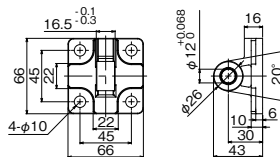

Non-motor end specification

Model **NM** **Applicable Models** Models other than EC-RP4/GS4/GD4

Description Although the home position is usually located on the motor side, it can be reversed as an option according to the requirement of the facility layout.

PNP specification

Model **PN** **Applicable Models** All Models

Description The EC series offers NPN specification input/output for connecting external devices as standard. Specifying this option changes input/output to PNP specification.

Clevis bracket

Model **QR** **Applicable Models** EC-RR6/RR7/RR6□AH/RR7□AH/RR6□R/RR7□R/RR6□AHR/RR7□AHR

Description This bracket makes the actuator unit follow the rod movement when the movement of the object attached to the rod tip is different from that of the rod.
Please use with a knuckle joint (NJ or NJPB) together as a set.

EC-RR6/RR6□R Single unit model: EC-QR-RR6

* Not shipped assembled. Refer to the drawing to mount.
When making adjustments, we recommend that the parallelism fall within the level mentioned on the mechanical drawings provided.

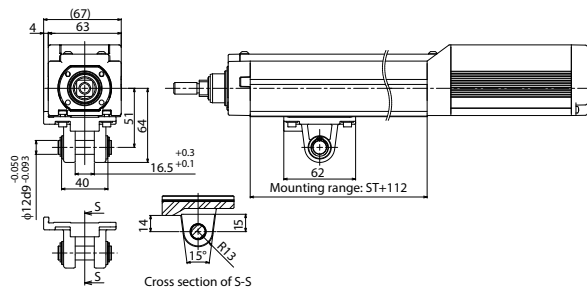

EC-RR7/RR7□R Single unit model: EC-QR-RR7

* Not shipped assembled. Refer to the drawing to mount.
When making adjustments, we recommend that the parallelism fall within the level mentioned on the mechanical drawings provided.

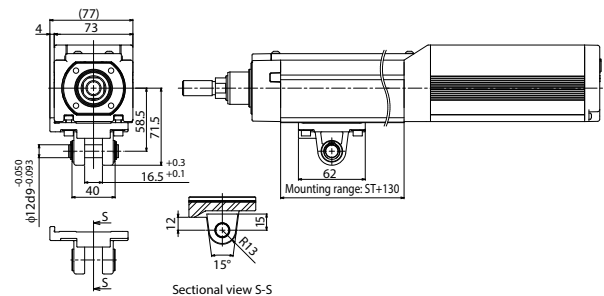

EC-RR6□AH/RR6□AHR Single unit model: EC-QR-RR6

* Not shipped assembled. Refer to the drawing to mount.
When making adjustments, we recommend that the parallelism fall within the level mentioned on the mechanical drawings provided.

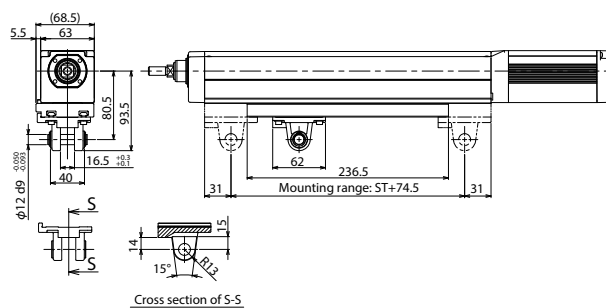

EC-RR7□AH/RR7□AHR Single unit model: EC-QR-RR7

* Not shipped assembled. Refer to the drawing to mount.
When making adjustments, we recommend that the parallelism fall within the level mentioned on the mechanical drawings provided.

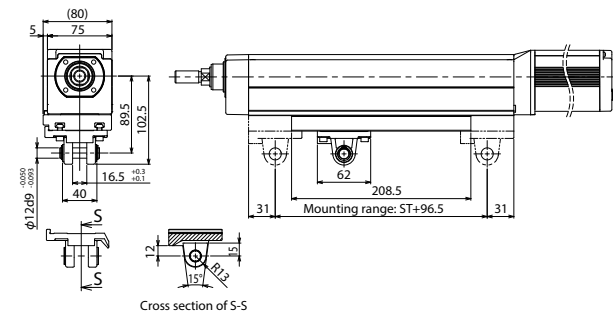

Clevis bracket + oscillation receiving bracket

Model **QRPB** **Applicable Models** EC-RR6/RR7/RR6□AH/RR7□AH/RR6□R/RR7□R/RR6□AHR/RR7□AHR

Description This is the oscillation receiving bracket with the clevis. The mounting method of the oscillation receiving bracket is the same as NJPB. Please use with a knuckle joint (NJ or NJPB) together as a set.

EC-RR6/RR6□R Single unit model: EC-QRPB-RR6

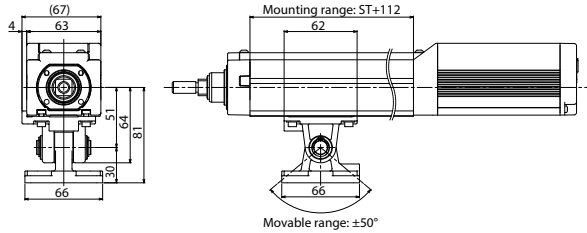

EC-RR7/RR7□R Single unit model: EC-QRPB-RR7

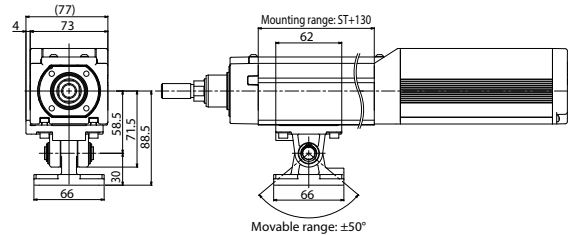

EC-RR6□AH/RR6□AHR Single unit model: EC-QRPB-RR6

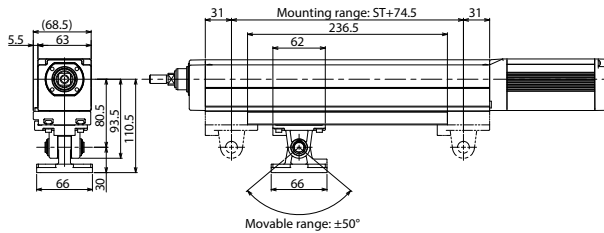

EC-RR7□AH/RR7□AHR Single unit model: EC-QRPB-RR7

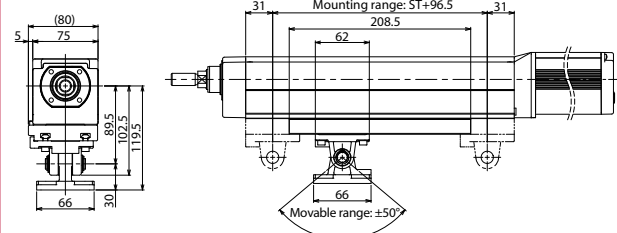

Sealing material specification

Model **SLF** **Applicable Models** EC-R6□W/R7□W/RR6□W/RR7□W

Description The sealing material is changed from NBR (Nitrile rubber) to FKM (fluororubber).

Split motor and controller power supply specification

Model **TMD2** **Applicable Models** All Models

Description Optional item to supply motor power and control power separately. Please refer to P120 for wiring details.

Battery-less Absolute Encoder specification

Model **WA** **Applicable Models** All Models

Description The EC series offers incremental encoder specification as standard. Specifying this option installs a built-in battery-less absolute encoder.

Wireless communication specification

Model **WL** **Applicable Models** All Models

Description Optional item is for wireless communications. By specifying this option, wireless communications with the teaching pendant TB-03 become available. Please refer to P120 for wiring details.

Wireless axis-operation specifications

Model **WL2** **Applicable Models** All Models

Description By specifying WL2, all the wireless operations of WL (adjusting the starting point, the end point, and the AVD) are available, and test operation of axis movements (moving to forward/backward ends, jogging, and inching) are also possible. However, using this function for automated operations is not possible. Please refer to P126 for cautions on axis operations using wireless connection. Alterations from WL to WL2, or vice versa cannot be made by customer. Please contact IAI.

Radial load acting on the rod

Because the radial cylinder has a linear guide built into the body, radial and moment loads can be applied to the rod. The allowable radial and moment loads must meet the following three conditions.

1. The radial load acting on the rod must not exceed the allowable value.

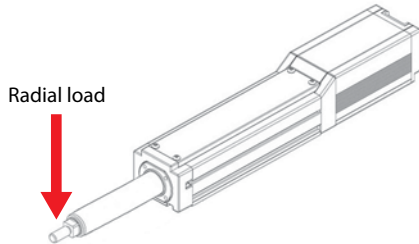

Type	Rod tip static allowable radial load	Rod tip dynamic allowable radial load (*1)
RR3/RR4	40N	20N
RR6/RR6□R/RR6□W	90N	45N
RR7/RR7□R/RR7□W	120N	60N

Type	Static allowable radial load on rod tip	Dynamic allowable radial load on rod tip (*1)					
		Stroke (mm)					
		50~250	300	350	400	450	500
RR6□AH/RR6□AHR	190N	130N	40N	35N	25N	–	–
RR7□AH/RR7□AHR	250N	170N	50N	45N	40N	35N	30N

(*1) In case of the standard rated service life of 5,000km.

2. The torque (Mc) acting on the rod must not exceed the allowable value.

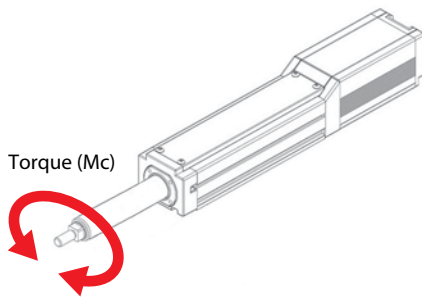

Type	Rod tip static allowable torque	Rod tip dynamic allowable torque (*2)
RR3/RR4	3.5N·m	3.5N·m
RR6 /RR6□R/RR6□W	5.5N·m	5.5N·m
RR7 /RR7□R/RR7□W	10.5N·m	10.5N·m
RR6□AH/RR6□AHR	9N·m	5.5N·m
RR7□AH/RR7□AHR	17.6N·m	10.5N·m

(*2) In case of the standard rated service life of 5,000km.

3. The uniform load acting on the rod must not exceed the allowable value.

The uniform load is obtained by the following formula.

$$\text{Uniform load} = Ma \cdot Ka + Mb \cdot Kb + Mc \cdot Kc$$

Type	Static allowable uniform load	Dynamic allowable uniform load (*3)	Load uniform coefficient Ka	Load uniform coefficient Kb	Load uniform coefficient Kc
RR3	1440N	580N	209/m	147/m	131/m
RR4	1720N	660N	181/m	127/m	93/m
RR6/RR6□R/RR6□W	4400N	1050N	124/m	87/m	62/m
RR7/RR7□R/RR7□W	5680N	1260N	98/m	69/m	50/m
RR6□AH/RR6□AHR	6700N	2400N	104/m	87/m	62/m
RR7□AH/RR7□AHR	11400N	3000N	90/m	76/m	50/m

(*3) Value at a standard rated life of 5,000km.

Ma, Mb, Mc: Moment load

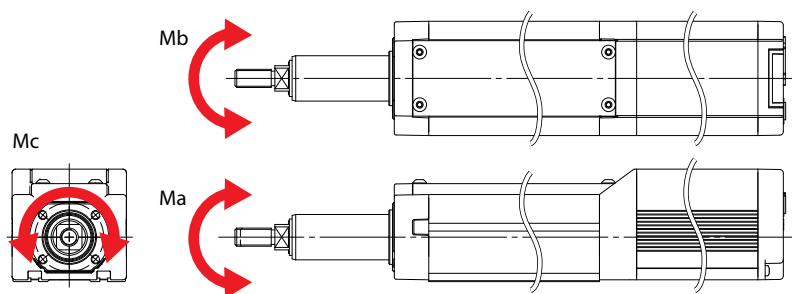

Moment offset reference position

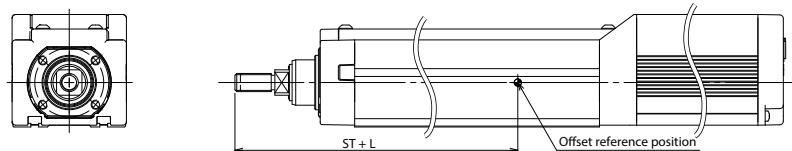

Type	L
RR3	73mm
RR4	102mm
RR6/RR6□R	111mm
RR7/RR7□R	144.5mm
RR6□W	131.3mm
RR7□W	161.5mm
RR6□AH/RR6□AHR	126mm
RR7□AH/RR7□AHR	153.5mm

(Caution) The radial load applied on the rod should not exceed the allowable offset and allowable overhang distance.

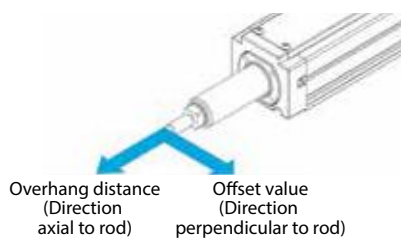

Type	Allowable offset value	Allowable overhang distance
RR3/RR4	100mm	100mm
RR6/RR6□R/RR6□W	100mm	100mm
RR7/RR7□R/RR7□W	100mm	100mm
RR6□AH/RR6□AHR	100mm	100mm
RR7□AH/RR7□AHR	150mm	150mm

* Even when the overhang distance and load moment are within the allowable range, the operating conditions should be moderated if some abnormal vibration or noise is observed.

* The center of gravity of the attached object should be less than the offset value or less than 1/2 of the overhang distance.

EC dust- and splash-proof specification Table of Solution-Resistance by Material

■ EC-R□W/RR□W

Name		NBR Nitrile rubber	PVC Polyvinyl chloride	FKM Fluorine rubber
		Standard	Standard	Optional
Water-soluble cutting oil		○	○	△
Non-water-soluble cutting oil		△	○	○
Cleaning fluid		○	○	○
Lubricating oil	Engine oil	○	○	○
	Gear oil	○	○	○
	Torque converter oil	○		○
	Brake oil (glycol based)	△		×
	Brake oil (silicone based)	○		○
	Machine oil	○		○
	Spindle oil	○		○
	Refrigerator oil (mineral oil)	○		○
	Cup grease	○		○
	Lithium grease	○	○	○
	Silicon grease	○	○	○
Hydraulic oil	General petroleum	○	○	○
	Low temperature petroleum	○	○	○
	Fatty acid ester based oil	○		○
	Phosphoric ester based oil	×		△
	Water-glycol based oil	○	○	△
	Water-oil emulsion based oil	○	○	△
	Turbine oil Class 2	○		○
	Silicon based oil	○		○
	Brake oil	△		△
Chemicals	Hydrochloric acid 10% solution	○	○	○
	Sulfuric acid 30% solution	△		△
	Nitric acid 10% solution	×		△
	Sodium hydroxide 40% solution	○		×
	Benzene	×	×	×
	Alcohol	○		○
	Methyl ethyl ketone	×	×	×
	Trichlen	×	×	△
	Ethylene glycol	○	×	○
	Acetone	×	×	×
Others	Gasoline	△	×	○
	Distillate/ fuel oil	△		○
	Heavy oil	○		○
	Antifreeze solution (Ethylene glycol based)	○		×
	Water/hot water	○	○	○
	Sea water	○		○

Judgment	Effects by solution to the seal part
○	Usable: only minor effects
△	Check before use: may result in significant effects
×	Do not use: will result in major effects

*1 Judgment may vary depending on the brand

*2 The table of solution resistance is based on IAI's internal evaluation and general evaluations. Please use the data as a selection guide.

*3 Judgement may vary depending on the environment and operating conditions. Please confirm before use if there is a potential effect.

*4 We carry out resistance tests of customer-specified solutions. Please contact us if you would like a test.

EC dust- and splash-proof specification Materials of Exterior Components

■EC-R6□W/R7□W

Name		Material	Treatment	
Exterior Components	① Frame	Extruded aluminium	Black alumite	
	② Rod	Drawn aluminium	Hard alumite	
	③ Rear bracket	Aluminium die cast		
	④ Motor cover	Extruded aluminium	Black alumite	
	⑤ End cover	Aluminium die cast		
	⑥ Front fixing nut	Steel	Trivalent chromate	
	⑦ Front bracket	Aluminium die cast		
	⑧ Tip metal	Stainless steel		
	⑨ Rubber cap (for grease nipple)	Standard	Rubber (NBR)	
		Option	Rubber (FKM)	
	⑩ Scraper	Standard	Rubber (NBR)	
		Option	Rubber (FKM)	
	⑪ Exhaust port	Standard	NBR+resin (PBT/POM) + Brass	Nickel plating
		Option	FKM+resin (PBT/POM) + Brass	Nickel plating
	⑫ Actuator pigtail cable	Pigtail seal	Standard	Rubber (NBR) + PBT resin + Nylon
Option			Rubber (FKM) + PBT resin + PP	
Cable jacket		Standard	Polyvinyl chloride (PVC)	
Exterior bolts		Rubber (FKM)		
Sealing parts	Standard	Stainless steel		
	Option	Rubber (NBR)		
		Rubber (FKM)		

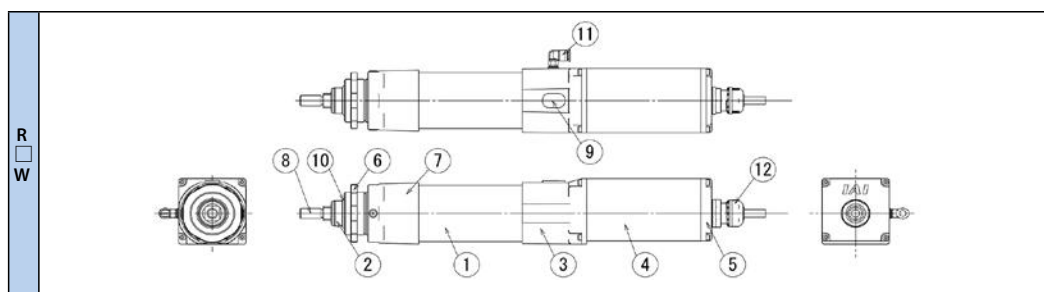

■EC-RR6□W/RR7□W

Name		Material	Treatment	
Exterior Components	① Base	Extruded aluminium	Black alumite	
	② Rod	Drawn aluminium	Hard alumite	
	③ Bearing housing	Aluminium die cast		
	④ Motor cover	Extruded aluminium	Black alumite	
	⑤ End cover	Aluminium die cast		
	⑥ Scraper case	Aluminium die cast		
	⑦ Front bracket	Aluminium die cast		
	⑧ Tip metal	Stainless steel		
	⑨ Frame cover	Extruded aluminium	Black alumite	
	⑩ Cap	Standard	Rubber (NBR)	
		Option	Rubber (FKM)	
	⑪ Rubber cap (grease port)	Standard	Rubber (NBR)	
		Option	Rubber (FKM)	
	⑫ Scraper	Standard	Rubber (NBR)	
		Option	Rubber (FKM)	
⑬ Grease nipple	Standard	Brass (C3604)		
	Option	Stainless steel		
⑭ Exhaust & intake port	Standard	NBR + resin (PBT/POM) + Brass	Nickel plating	
	Option	FKM + resin (PBT/POM) + Brass	Nickel plating	
⑮ Actuator pigtail cable	Pigtail seal	Standard	Rubber (NBR) + PBT resin + Nylon	
		Option	Rubber (FKM) + PBT resin + PP	
	Cable jacket	Standard	Polyvinyl chloride (PVC)	
Exterior bolts		Rubber (FKM)		
Sealing parts	Standard	Stainless steel		
	Option	Rubber (NBR)		
		Rubber (FKM)		

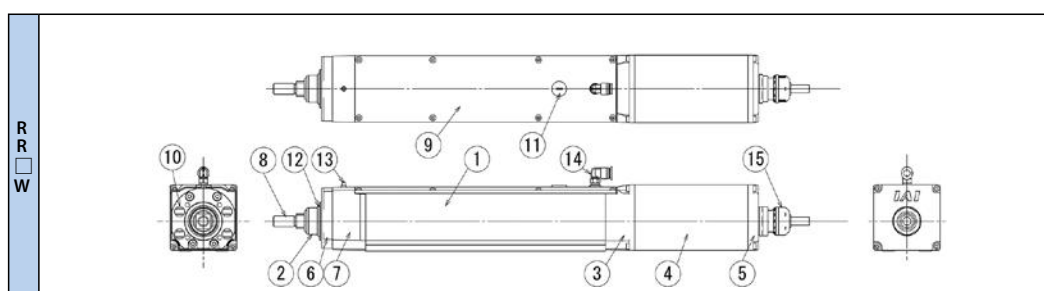

Correlation of push force and current limit value

When performing the push-motion operation with the slider type, and mini table type please limit the push current in order that the reactive moment caused by the push force does not exceed the dynamic allowable moment (Ma, Mb) in the catalog. Please refer to the figures below, which show the working point of the guide moment, for help with calculating the moment. This can be done by considering the offset of the push force application position. Please note that if excessive force which exceeds the dynamic allowable moment is applied, it may damage the guide and shorten its service life. Please keep this in mind and select a push current that is safely within its limits.

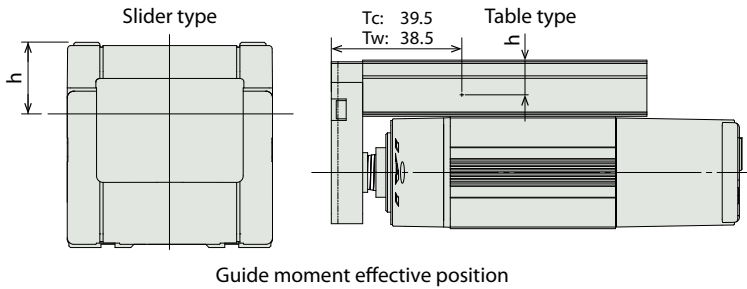

h dimension			
Slider type		Table type	
S3	16	TC4	10.5
S4	18	TW4	10.5
S6/S6□R	22		
S7/S7□R	22		
S6□H/S6□AHR	50.5		
S7□H/S7□AHR	58		

*Unit: mm

Calculation example

When 200N push operation is performed with EC-S7 at the position shown in the figure at right, the moment applied to the guide is:

$$Ma = (22+50) \times 200 = 14400 \text{ (N}\cdot\text{mm)}$$

$$= 14.4 \text{ (N}\cdot\text{m)}$$

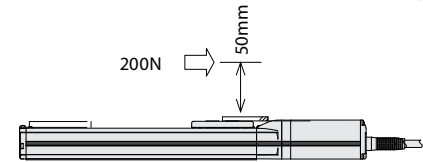

The dynamic allowable moment for EC-S7 is $Ma = 17.7 \text{ (N}\cdot\text{m)}$, which means it is OK since $17.7 > 14.4$.

Also, should an Mb moment occur due to the push operation, calculate the moment from the overhang and ensure that it is within range of the dynamic allowable moment.

Duty cycle

Duty cycle is the percentage of the actuator's active operation time in each cycle.

ELECYLINDER® types have limits on the duty ratio as shown below. The below graph also applies to usage at the maximum speed and maximum acceleration/deceleration.

(Note) The duty ratio for S3, S4, RR3, RR4, RP, GS, TC and TW is 100% at the ambient temperature 0 to 40°C.

■ Ambient temperature and duty ratio

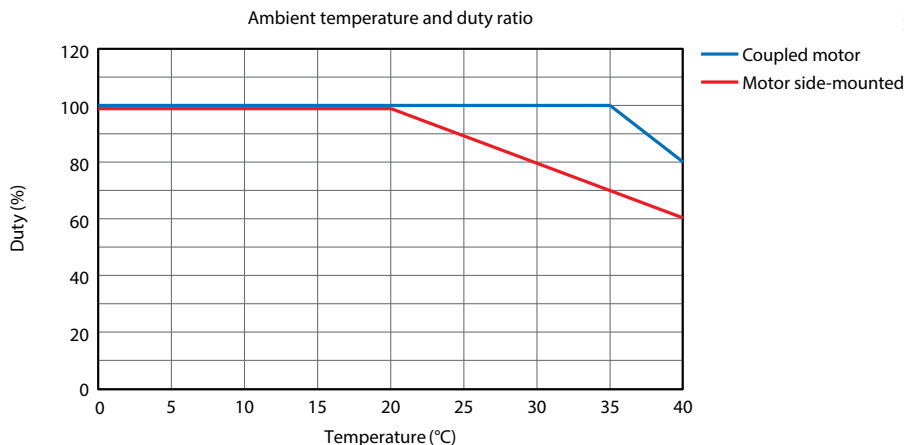

[Duty Cycle]

The duty ratio is the operating rate shown as the actuator's operating time during one cycle in %.

$$D = \frac{T_u}{T_u + T_{st}} \times 100 \text{ (%)}$$

D: Duty
T_u: Operating time (including push-motion operation)
T_{st}: Stop time

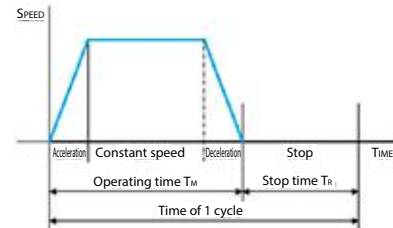

System Configuration

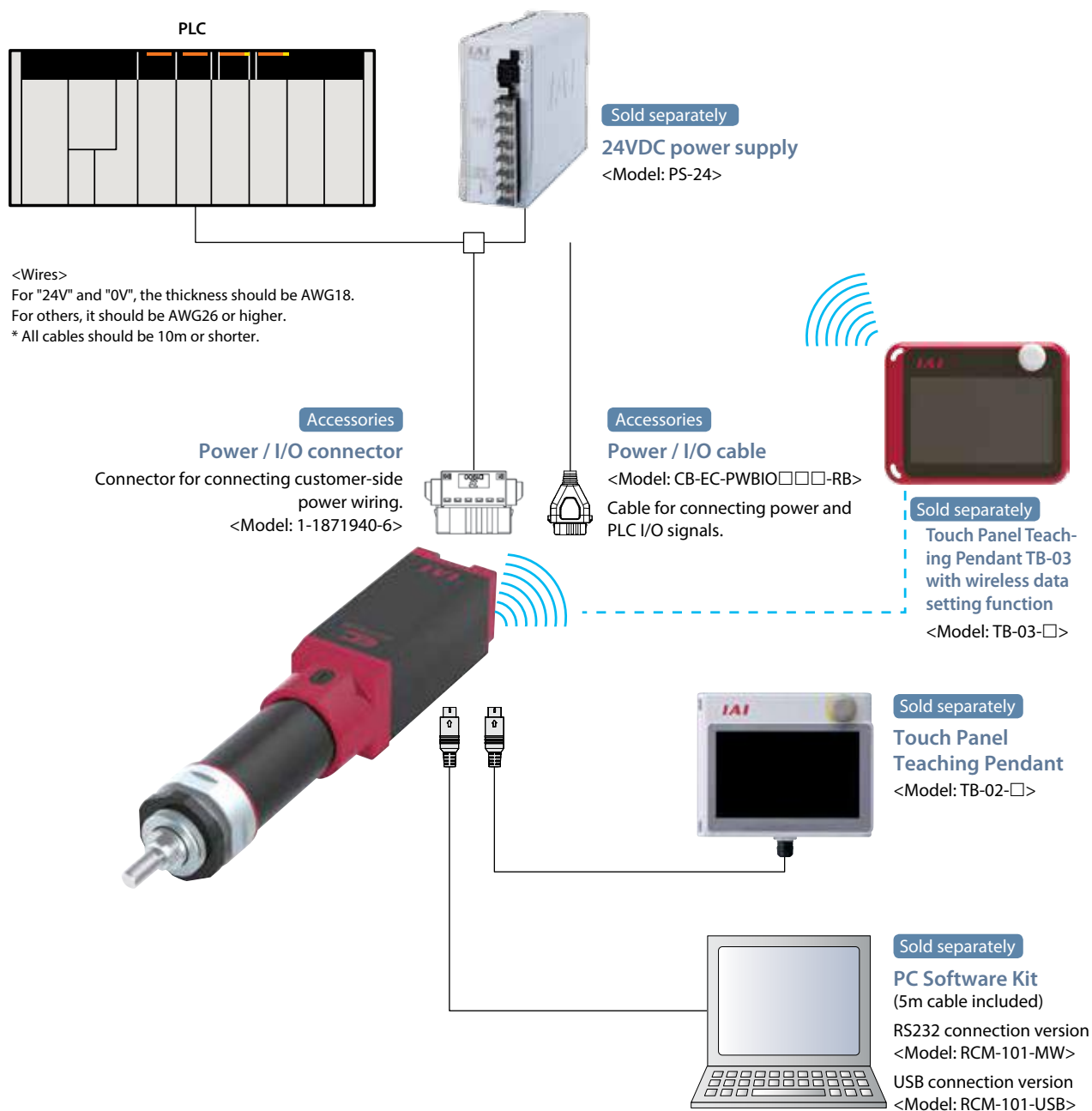

List of Accessories

Product category	Accessories
Without EC power / I/O cable (When cable length "0" is selected for actuator type)	Power / I/O connector (1-1871940-6)
With EC power / I/O cable (When cable length 1 to 10 is selected for actuator type)	Power / I/O cable (CB-EC-PWBIO□□□-RB)

System Configuration

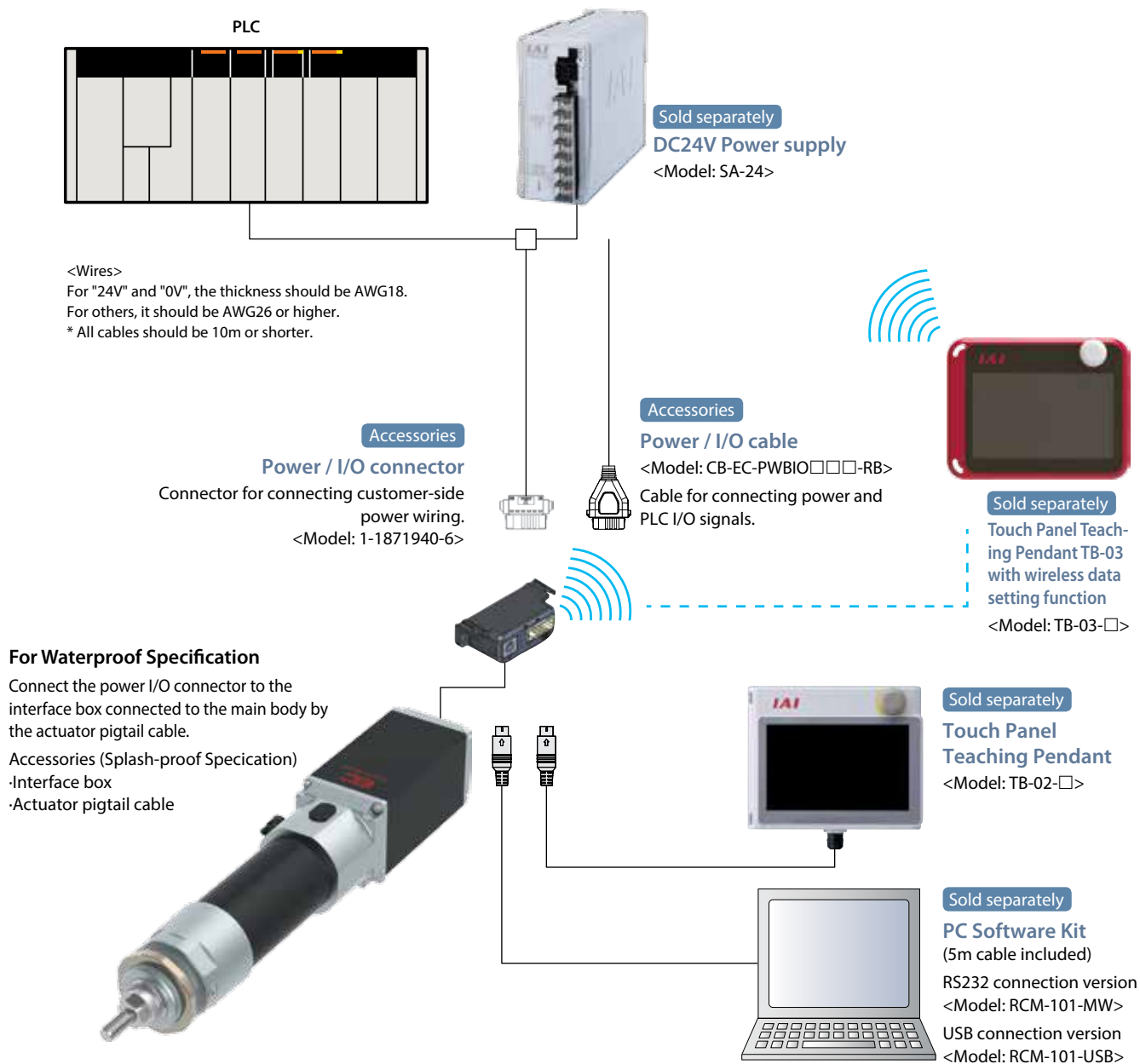

List of Accessories

Product category	Accessories
Without EC power / I/O cable (When cable length "0" is selected for actuator type)	Power / I/O connector (1-1871940-6)
With EC power / I/O cable (When cable length 1 to 10 is selected for actuator type)	Power / I/O cable (CB-EC-PWBIO□□□-RB)
	Interface box (Splash-proof type)
	Interface cable (Splash-proof type)

Basic Controller Specifications

Specification item		Specification content	
Number of controlled axes		1 axis	
Power supply voltage		24VDC ±10%	
Power capacity	Standard	With energy-saving setting disabled: Rated 3.5A, max. 4.2A	
	Water proof	With energy-saving setting enabled: Rated 2.2A	
	High rigidity	(Energy-saving can only be enabled for the S3/RR3 with the maximum current of 2.2A.)	
	Mini type	Max. 2.0A (with energy-saving setting enabled only)	
Brake release power supply		24VDC ±10%, 200mA (only for external brake release)	
Generated heat		8W (at 100% duty)	
Inrush current	Standard	8.3A (with inrush current limit circuit)	
	Water proof		
	High rigidity		
	Mini type	10A	
Momentary power failure resistance		Max 500μs	
Motor size		□28, □35, □42, □56	
Motor rated current		1.2A	
Motor control system		Weak field-magnet vector control	
Supported encoders		Incremental (800pulse/rev), Battery-less absolute encoder (800 pulses/rev)	
SIO		RS485 1ch (Modbus protocol compliant)	
PIO	Input specification	Number of input	3 points (forward, backward, alarm clear)
		Input voltage	24VDC ±10%
		Input current	5mA per circuit
		Leakage current	Max 1mA/1 point
		Isolation method	Non-isolated
	Output specification	No. of output	3 points (forward complete, backward complete, alarm)
		Output voltage	24VDC ±10%
		Output current	50mA/1 point
Residual voltage		2V or less	
	Isolation method	Non-isolated	
Data setting and input methods		PC software kit / Touch panel teaching pendant	
Data retention memory		Position and parameters are saved in non-volatile memory. (No limit to rewrite)	
LED display	Controller status display	Servo ON (green light ON) / Alarm (red light ON) / Initializing when power comes ON (orange light ON) / Minor failure alarm (green/red alternately blinking) / Operation from teaching: Stop from teaching (red light ON) / Servo OFF (light OFF)	
	Wireless status display	Initializing wireless hardware, without wireless connection, or connecting from TP board (light OFF) Connecting through wireless (green blinking) / Wireless hardware error (red blinking) / Initializing when power comes ON (orange light ON)	
Predictive maintenance/ Preventative maintenance		When the number of movements or operation distance has exceeded the set value and when the LED (right side) blinks alternately green and red at overload warning * Only when configured in advance	
Ambient operating temperature		0 to 40°C	
Ambient operating humidity		85% RH or less (no condensation or freezing)	
Operating ambience		Avoid corrosive gas and excessive dust	
Insulation resistance		DC500V 10MΩ	
Electric shock protection mechanism		Class 1 basic insulation	
Cooling method		Natural air cooling	

I/O Specification (Input/Output specifications)

I/O		Input	Output	
Specifications	Input voltage	DC24V±10%	Load voltage	DC24V±10%
	Input current	5mA/circuit	Max. load current	50mA/point
	ON/OFF Voltage	ON voltage MIN DC18V OFF voltage MAX DC6V	Residual voltage	2V or less
	Leak current	MAX 1mA/point	Leak current	MAX 0.1mA/point
Insulation method		Not isolated from external circuit		
I/O logic	NPN			
	PNP			

I/O Specification Wiring Diagram

I/O		Standard Specification	TMD2 Specification (Option)
Power • I/Oconnector		<p>0V A1 (Spare) A2 Backward complete A3 Forward complete A4 Alarm output A5 (Spare) A6</p> <p>B1 24V B2 Brake release B3 Backward command B4 Forward command B5 Alarm release B6 (Spare)</p>	<p>The TMD2 specification is a specification in which the motor power and control power are separated.</p> <p>0V A1 24V(Control) A2 Backward complete A3 Forward complete A4 Alarm output A5 (Spare) A6</p> <p>B1 24V(Drive) B2 Brake release B3 Backward command B4 Forward command B5 Alarm release B6 (Spare)</p>
I/O logic	NPN		
	PNP		

I/O Signal Table

Pin assignment for power I/O connector			
Pin No.	Connector tag plate name	Signal abbreviation	Description of command
B3	Backward	ST0	Backward command
B4	Forward	ST1	Forward command
B5	Alarm release	RES	Alarm reset
A3	Backward complete	LS0/PE0	Backward complete/Pushing complete
A4	Forward complete	LS1/PE1	Forward complete/Pushing complete
A5	Alarm	*ALM	Alarm detected (contact point b)
B2	Brake release	BKRLS	Forced release of brake (for "with brake" specification)
B1 (Note)	24V	24V	24V input
A1	0V	0V	0V input
A2 (Note)	(24V)	(24V)	24V input

(Note) In the case of dual power supply specifications (TMD2), B1 is 24V (drive) and A2 is 24V (control).

I/O Options

Touch Panel Teaching Pendant

Features A teaching device equipped with functions such as position teaching, trial operation, and monitoring.

Model TB-02-□

Please contact IAI for the current supported versions.

Configuration Wired connection

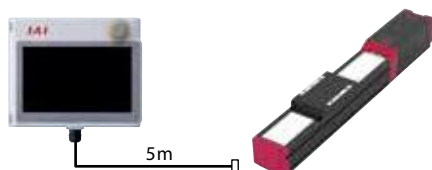

Specifications

Rated voltage	24V DC
Power consumption	3.6W or less (150mA or less)
Ambient operating temperature	0 to 40°C
Ambient operating humidity	20~ 85% RH (Non-condensing)
Environmental resistance	IP20
Mass	470g (TB-02 unit only)

Touch Panel Teaching Pendant

Features Teaching device for wireless connection. Start/End positions and AVD data can be input wirelessly.

Model TB-03-□

Please contact IAI for the current supported versions.

Configuration Wireless or wired connection

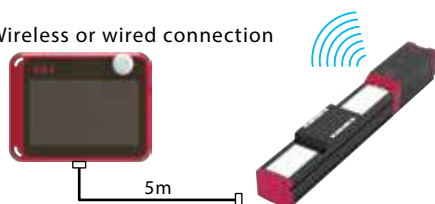

Specifications

Rated voltage	24V DC
Power consumption	3.6W or less (150mA or less)
Ambient operating temperature	0 to 40°C
Ambient operating humidity	20~ 85% RH (Non-condensing)
Environmental resistance	IPX0 (not water resistant)
Mass	670g (TB-03 unit only)
Charging method	Wired connection with dedicated AC adapter /controller
Wireless connection	Bluetooth4.2 class2

Options

PC software (Windows only)

- **Features** The start-up support software which comes equipped with functions such as position teaching, trial operation, and monitoring. A complete range of functions needed for making adjustments contributes to decreasing the start-up time.

- **Model** **RCM-101-MW (with an external device communication cable + RS232 conversion unit)**

Please contact IAI for the current supported versions.

- **Configuration**

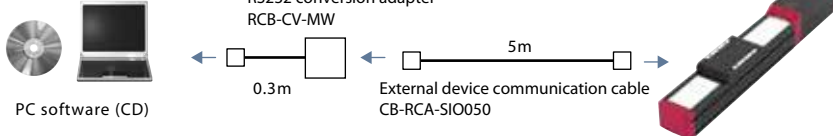

- **Model** **RCM-101-USB (with an external device communication cable + USB conversion adapter + USB cable)**

Please contact IAI for the current supported versions.

- **Configuration**

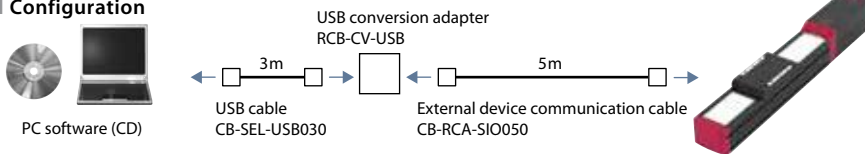

Supported Windows versions: 7/8/10



Maintenance Parts

When placing an order for a replacement cable, please use the model name shown below.

- **Compatible cables**

Model name	Power / I/O cable
EC	CB-EC-PWBIO□□□-RB

Model **CB-EC-PWBIO□□□-RB**

* Please indicate the cable length (L) in □□□, E.g.) 030 = 3m

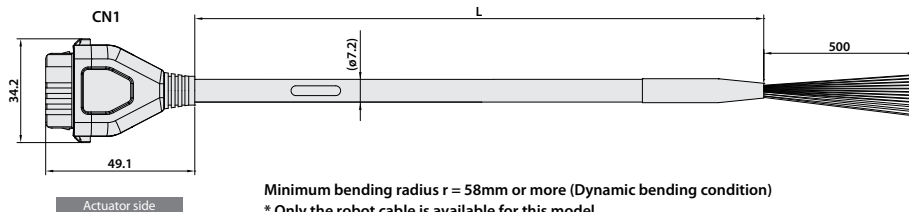

Minimum bending radius $r = 58\text{mm}$ or more (Dynamic bending condition)
 * Only the robot cable is available for this model.
 (Standard non robot cable unavailable)

Color	Signal name	Pin No.
Black (AWG18)	0V	A1
Red (AWG18)	24V	B1
Light blue (AWG22)	(reserve)	A2
Orange (AWG26)	IN0	B3
Yellow (AWG26)	IN1	B4
Green (AWG26)	IN2	B5
Pink (AWG26)	(reserve)	B6
Blue (AWG26)	OUT0	A3
Purple (AWG26)	OUT1	A4
Gray (AWG26)	OUT2	A5
White (AWG26)	(reserve)	A6
Brown (AWG26)	BKRLS	B2

MEMO

A series of horizontal dotted lines for writing.

TB-03

Touch Panel Teaching Pendant TB-03 with wireless data setting function
Touch panel teaching pendant TB-03



1. Set operating conditions with wireless connection

Position adjustment and operating conditions can be set from outside the equipment, even without a cable connection to the ELECYLINDER® body.

* Actuator operation requires cable connection.



As for ELECYLINDER® that can be operated by wireless, the wireless function differs depending on the description of ELECYLINDER® model type option.
"-WL" for Edit only
"-WL2" for Edit and Operation

2. Status monitoring makes daily maintenance easier and shortens trouble recovery time

TB-03 can monitor the operating status of up to 16 axes while receiving wireless data from the ELECYLINDER®. Error recovery time also can be shortened by troubleshooting with wireless communication.

Status monitor screen

EC2 S/N A70761788 Selectable	Servo Cur. pos. 0.00 mm	Travel Cnt. Travel Dist. Over load Lv.	52 1 m 12 %	Alarm Group Warnin Maintenance warning 1
------------------------------------	-------------------------------	--	-------------------	---

Axis Name Display
Can be configured (changed) arbitrarily according to customer applications.

Status Monitor
Axis status check can be used for confirmation of maintenance timing.

Error Status Monitor
Alarms and warnings are displayed when generated. Useful for troubleshooting.

Troubleshooting screen

3. Supports position/program controller

Dedicated cables can connect the TB-03 to all the controllers.
The same functions and operation of the previous TB-02 are available.
All the controllers specified in the general catalog published in 2018 or later.

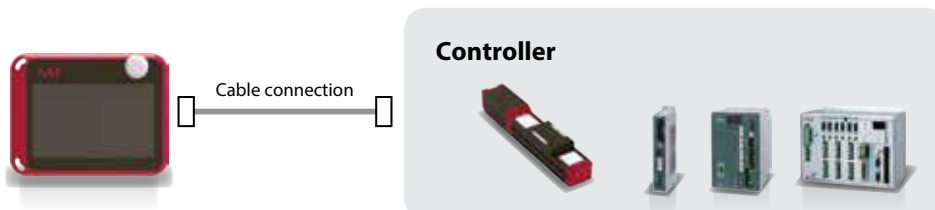

For the ELECYLINDER®, wired or wireless specification can be selected from the ELECYLINDER® model selection.

Model Number

One unit is compatible with all the controllers* though the right cable should be selected in order to connect with each controller type. In addition, an AC adapter for recharging the main unit should be selected according to the operating environment.

Model **TB-03** - **Cable** - **AC adapter**

* All the controllers specified in the general catalog published in 2018 or later.

● Body + cable + AC adapter set model

Connected controller	Model		Cable	
	Body + cable	AC adapter	For ELECYLINDER®/ position controller	For program controller
ELECYLINDER® Position Controller	TB-03-C	(Blank)/C/E/K	① CB-TB3-C050	-
		N *2		
Program Controller	TB-03-S	(Blank)/C/E/K	-	② CB-TB3-S050 + ③ CB-SEL-SJS002 (conversion cable) *3
		N *2		
ELECYLINDER® Position Controller Program Controller	TB-03-SC	(Blank)/C/E/K	① CB-TB3-C050	② CB-TB3-S050 + ③ CB-SEL-SJS002 (conversion cable) *3
		N *2		
	TB-03-SCN *1	(Blank)/C/E/K	-	-
		N *2		

*1 No cable

*2 No AC adapter

● Cable single product model number

Connected controller	Model
ELECYLINDER® Position Controller	① CB-TB3-C050
Program Controller	② CB-TB3-S050
	③ CB-SEL-SJS002 (conversion cable) *3

*3 Use with the ② cable when connecting to ASEL, PSEL, SSEL, or MSEL

● AC adapter single product model number

Connected controller	Model	Specification	Single product model number
ELECYLINDER® Position Controller Program Controller	(Blank)	For Japan/North America/Thailand	UN318-5928
	C	For China	UNZ318-5928
	E	For Europe	UNE318-5928
	K	For Korea	UNR318-5928

Connection

● Wireless connection (ELECYLINDER® only)

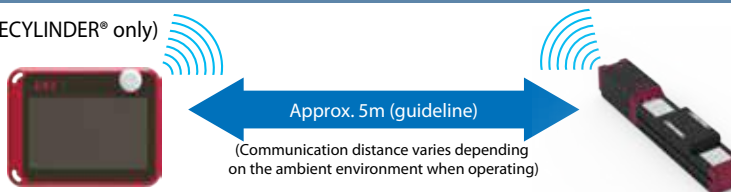

* Connectable only for models with "WL" (wireless communication) "WL2" (wireless axis-operation) options in the model number

Caution: Certification issues limit the countries in which wireless communication can be used. Contact our sales personnel for details.

● Wired connection (cable connection)

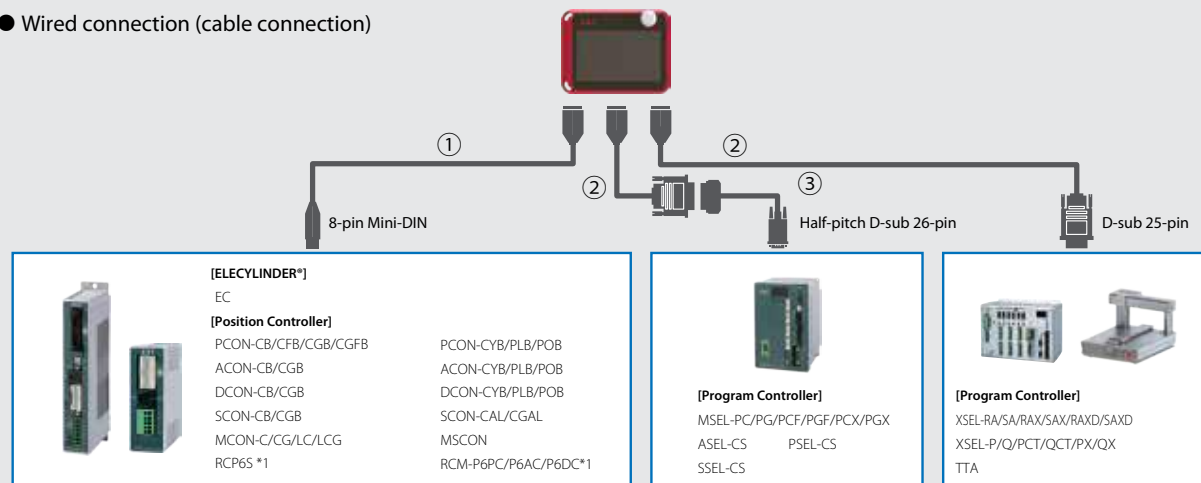

*1 To operate RCP65 and RCM-P6, a gateway unit or a PLC connection unit is necessary.

Body Specifications

Power input voltage range	24VDC ±10% [supplied from controller]
Power consumption	3.6W or less
Consumption current	150mA (supplied from controller)
Ambient operating temperature	0 to 40°C (no condensation or freezing)
Ambient operating humidity	85% RH or less (no condensation or freezing)
Ambient storage temperature	-20 to 40°C
Vibration resistance	10 to 57Hz Amplitude 0.075mm
Ingress protection	IPX0
Mass	670g (body) + approx. 285g (dedicated cable)
Liquid crystal	7" TFT color WVGA (800 x 480)
External memory	SD/SDHC memory card interface mounted (1G to 32G)
Charging method	Wired connection with dedicated AC adapter/controller
Language support	Japanese/English/Chinese

Wireless Function (when connected to ELECYLINDER® only)

Wireless connection	Bluetooth 4.2 Class 2
Wireless function	Data setting/Monitor function/Axis-operation
Operation command/stop command	No
Max. number of connectable axes	16 axes
Operation	Battery (AB-7) operation
Wireless operating time	Max. 4 hours (battery driven)
Battery life	Cycle durability 300 times

AC Adapter Common Specifications

Power input voltage range	Single-phase 100 to 240VAC ±10%
Power supply current	0.4A max.
Consumption current	2.8A max.
Output voltage	5.9VDC (5.7 to 6.3V)
Charging time	Approx. 3 hours
Cable length	1500 ±100mm

Name of Each Component



External Dimensions

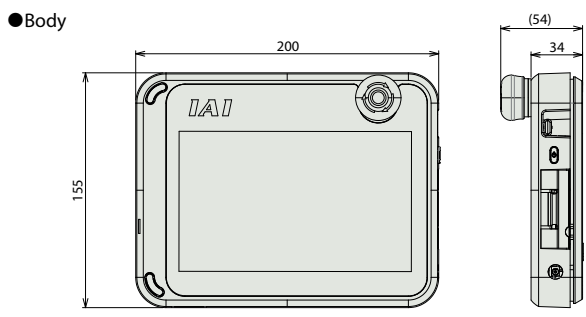

AC adapter

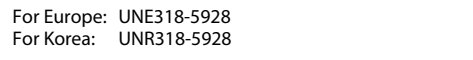
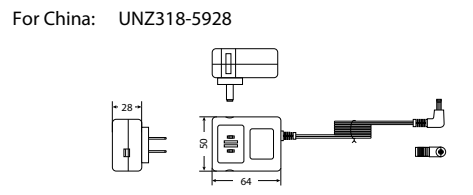
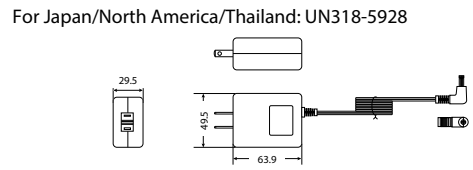

Options

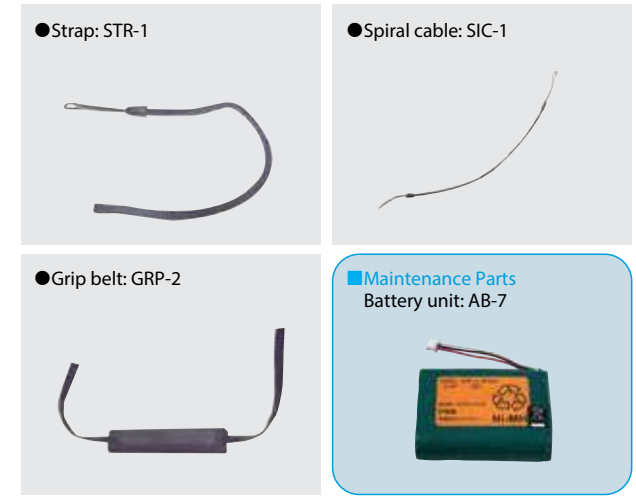

Cautions on Axis Operations via Wireless Connection

This device (V2.30 or later) can operate the ELECYLINDER® whose option model number is :WL2 via wireless connection. When performing a wireless operation, make sure to check safety according to the following instructions:

- During a wireless operation, **the stop switch on this device does NOT function.** Make sure to prepare a device or circuit for emergency stops.



- Although the operation of ELECYLINDER® via wireless connection allows test operations (moving to forward/backward ends, jogging and inching), **it is not a function to perform an automated operation.** Make sure to build a mechanical system according to the risk of the operating environment.
- **Carry out a risk assesment according to the requirements specified by the standard for the machinery built in the system.** It is not allowed to perform dangerous operations such that the system must stop automatically when the control signals are not received due to communication interruptions.
- The stop operation by axis operation using wireless cannot be used as the safety function specified in EN ISO 13849-1: 2015. Neither does it conform to the safety categories B and 1 to 4 of the EN ISO 13849-1: 2015

Cautions on wireless operations

- This product uses a 2.4GHz electrical wave called the ISM band (wireless frequency 2,400 to 2483.5MHz, wireless output +5 dBm).
- Since this spectrum is used by many devices including microwaves and wireless LANs, communications may be interrupted due to radio disturbances.
- The use of this product is permitted only in the countries (regions) specified below:
In other countries (regions), it is necessary to obtain an certification according to the regulations in the country (region).

Japan, USA, Canada, EU countries, China, Korea and Thailand

IAI offers a complete national and international support network

SUPPORT A network of authorized representatives in the US to serve you.

Support for phase of planning, product selection, quotation, problem solving, maintenance, training, etc.

<http://www.intelligentactuator.com/inquiry/>



USA
 ● Sales & Support Centers
 ● 12 Sales Offices
 ■ 48 local Distributors

CANADA
 ■ 5 local Distributors

MEXICO
 ■ 1 local Distributor

★ IAI AMERICA (CA) US Headquarters

Chicago Office (IL)

Atlanta Office (GA)

日本語 OK TEC 日本製 修理 工具

IAI America, Inc.

- **US Headquarters**
 2690 W. 237th Street, Torrance, CA 90505
 Phone 800-736-1712 FAX 310-891-0815
 URL www.intelligentactuator.com
- **Chicago Office**
 110 E. State Parkway, Schaumburg, IL 60173
 Phone 800-944-0333 FAX 847-908-1399
- **Atlanta Office**
 1220 Kennestone Circle, Suite 108, Marietta, GA 30066
 Phone 888-354-9470 FAX 678-354-9471

The information contained in this booklet may change without prior notice due to product improvement.

■ Contact us for your local distributor information.

International Network

Support available in 200 locations across 30 countries around the world
 Various seminars can be organized locally

- **Europe**
 1 Group Location
 22 Dealers
 Technical Support
 Japanese Language Support
 Global Support (Broader-based support)
 Simple Repair
- **Thailand**
 ● **Vietnam**
 ● **Philippines**
 ● **Malaysia**
 1 Group location
 Technical Support
 Japanese Language Support
 Simple Repair
- **China**
 3 Group Locations / 34 Dealers in 117 Locations
 Technical Support
 Global Support (Broader-based support)
 Japanese Language Support
 Simple Repair
- **South Korea**
 Technical Support
 Japanese Language Support
 Simple Repair
- **Japan**
 Corporate Headquarter
 25 Branches and Plants
 Corporate HQ
 Manufacturing
 Technical Support
 Product Stock
 Repair
 Global Support (Broader-based support)
- **Singapore** ● **Taiwan**
 Technical Support
 Simple Repair
- **USA**
 3 Group Locations
 48 + Distributors
 Technical Support
 Japanese Language Support
 Global Support (Broader-based support)
 Simple Repair
- **Brazil**
 1 Consigned Retailer
 Technical Support
 Simple Repair
 Japanese Language Support

MEMO

A series of horizontal dotted lines for writing.

MEMO

A series of horizontal dotted lines for writing.

MEMO

A series of horizontal dotted lines for writing a memo.

IAI America, Inc.

Headquarters: 2690 W. 237th Street, Torrance, CA 90505 (800) 736-1712
Chicago Office: 110 E. State Pkwy, Schaumburg, IL 60173 (800) 944-0333
Atlanta Office: 1220 Kennestone Circle, Suite 108, Marietta, GA 30066 (888) 354-9470

www.intelligentactuator.com

The information contained in this product brochure may change without prior notice due to product improvements.

IAI Industrieroboter GmbH

Ober der Röth 4, D-65824 Schwalbach am Taunus, Germany

IAI (Shanghai) Co., Ltd.

Shanghai Jiahua Business Center A8-303, 808,
Hongqiao Rd., Shanghai 200030, China

IAI Robot (Thailand) Co., Ltd.

825 Phairojkijja Tower 12th Floor, Bangna-Trad RD.,
Bangna, Bangna, Bangkok 10260, Thailand